

## Stability of split Stirling refrigerators

**Citation for published version (APA):**

Waele, de, A. T. A. M., & Liang, W. (2009). Stability of split Stirling refrigerators. *Journal of Physics: Conference Series*, 150(1), 012010-1/4. <https://doi.org/10.1088/1742-6596/150/1/012010>

**DOI:**

[10.1088/1742-6596/150/1/012010](https://doi.org/10.1088/1742-6596/150/1/012010)

**Document status and date:**

Published: 01/01/2009

**Document Version:**

Publisher's PDF, also known as Version of Record (includes final page, issue and volume numbers)

**Please check the document version of this publication:**

- A submitted manuscript is the version of the article upon submission and before peer-review. There can be important differences between the submitted version and the official published version of record. People interested in the research are advised to contact the author for the final version of the publication, or visit the DOI to the publisher's website.
- The final author version and the galley proof are versions of the publication after peer review.
- The final published version features the final layout of the paper including the volume, issue and page numbers.

[Link to publication](#)

**General rights**

Copyright and moral rights for the publications made accessible in the public portal are retained by the authors and/or other copyright owners and it is a condition of accessing publications that users recognise and abide by the legal requirements associated with these rights.

- Users may download and print one copy of any publication from the public portal for the purpose of private study or research.
- You may not further distribute the material or use it for any profit-making activity or commercial gain
- You may freely distribute the URL identifying the publication in the public portal.

If the publication is distributed under the terms of Article 25fa of the Dutch Copyright Act, indicated by the "Taverne" license above, please follow below link for the End User Agreement:

[www.tue.nl/taverne](http://www.tue.nl/taverne)

**Take down policy**

If you believe that this document breaches copyright please contact us at:

[openaccess@tue.nl](mailto:openaccess@tue.nl)

providing details and we will investigate your claim.

# Stability of split Stirling refrigerators

A.T.A.M. de Waele and W. Liang

Department of Applied Physics, Eindhoven University of Technology  
Eindhoven, The Netherlands

May 28, 2008

## Abstract

In many thermal systems spontaneous mechanical oscillations are generated under the influence of large temperature gradients. Well-known examples are Taconis oscillations in liquid-helium cryostats and oscillations in thermoacoustic systems. In split Stirling refrigerators the compressor and the cold finger are connected by a flexible tube. The displacer in the cold head is suspended by a spring. Its motion is pneumatically driven by the pressure oscillations generated by the compressor. In this paper we give the basic dynamic equations of split Stirling refrigerators and investigate the possibility of spontaneous mechanical oscillations if a large temperature gradient develops in the cold finger, e.g. during or after cool down. These oscillations would be superimposed on the pressure oscillations of the compressor and could ruin the cooler performance.

## 1 Introduction

The basic dynamics of split Stirling refrigerators is described in [1]. It was shown that, under certain conditions, the system can operate as an engine rather than as a cooler. This means that it is conceivable that spontaneous oscillations can be present which are superposed on the forced motion due to the external force. These "spontaneous" oscillations can affect the overall performance of the system. In this mathematical paper we derive relations which determine the stability of split Stirling refrigerators driven by a linear compressor.

## 2 System description

### 2.1 Components

A split Stirling cryocooler consists of a compressor connected to a cold finger via a pipe (Fig.1). In the cold finger the regenerator also acts as the displacer. The regenerator is fixed to a mechanical spring and a guiding rod which sticks into a backing volume **f**. The motion of the regenerator is driven by the pressure differences between spaces **d** and **e** and the between spaces **d** and **f** respectively. The compressor is represented as a mass-spring system driven by an external force  $F$  which puts a power  $P$  into the system.

Many of the parameters describing the system are defined in Fig.1. The cold head absorbs heat at a rate  $\dot{Q}_L$  at a temperature  $T_L$ . Room temperature will be denoted by  $T_H$ . The heat and power flow in the figure apply to the situation of a refrigerator with  $T_L$  below room temperature in mind. However, our formalism is also valid if  $T_L > T_H$  and the system operates as a heat engine. The pressures in the system all vary around an average value  $p_0 = \bar{p}$  according to  $p = p_0 + \delta p$ . We assume that the pressure variations are small compared to the average pressure  $|\delta p| \ll p_0$ . We also assume that the variations of the various

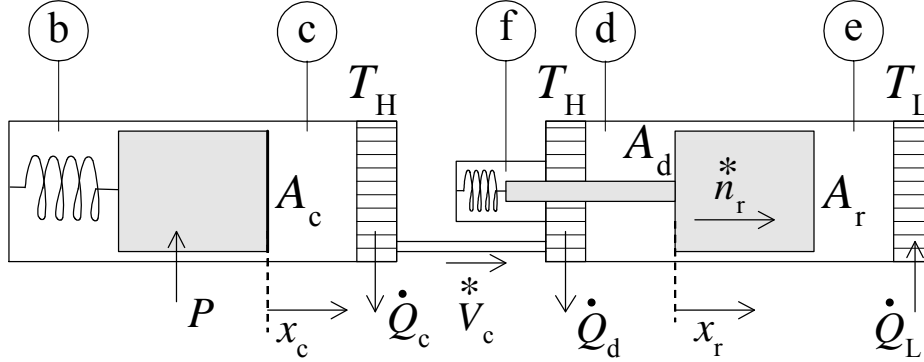

Figure 1: Schematic diagram of the split Stirling cryocooler indicating the sign convention and the labeling of the various components and spaces.

volumes are small (the average values of the volumes get lower index 0). These two assumptions allow linearization of the relations. We also assume zero flow resistance in the split pipe so that  $p_d = p_c$ . If the working fluid is an ideal gas which flows into a certain control volume  $V$  with volume flow  $\dot{V}_1^*$  and flows out with volume flow  $\dot{V}_2^*$  while the pressure  $p$  inside the volume changes adiabatically with time  $t$  then we have the powerful relation

$$\dot{V}_1^* = \frac{V}{\gamma p} \dot{p} + \dot{V}_2^*. \quad (1)$$

In this relation  $\gamma$  is the ratio of the heat capacities at constant pressure and constant volume of the working fluid.

## 2.2 Dynamic equations

Equation (1), applied to space **b**, gives

$$\dot{V}_b = -\frac{V_{b0}}{\gamma p_0} \dot{p}_b \quad (2)$$

and for **c** we have

$$A_c \dot{x}_c = \frac{V_{c0}}{\gamma p_0} \dot{p}_c + \dot{V}_c^*. \quad (3)$$

For **d** with flow conductance  $C$  of the regenerator which we assume to be temperature independent

$$\dot{V}_d = \dot{V}_c^* - \frac{V_{d0}}{\gamma p_0} \dot{p}_d + C p_r \quad (4)$$

with  $p_r = p_e - p_d$ . For volume **e**, and assuming zero void volume in the regenerator,

$$\dot{V}_e = -\frac{T_L}{T_H} C p_r - \frac{V_{e0}}{\gamma p_0} \dot{p}_e. \quad (5)$$

The equation of motion of the piston, with  $F$  the external force, which reads

$$m_c \ddot{x}_c = F + A_c (\delta p_b - \delta p_c) - k_c x_c - f_c \dot{x}_c \quad (6)$$

with  $m$  the mass of the piston,  $k$  the spring constant, and  $f$  the friction factor. For the piston the lower index  $c$  is used, for the regenerator we use  $r$ . Assuming a constant pressure  $p_0$  in  $\mathbf{f}$  the acceleration of the regenerator is given by

$$m_r \ddot{x}_r = p_0 A_f + p_d A_d - p_e A_r - k_r x_r - f_r \dot{x}_r. \quad (7)$$

The dynamics of the system is determined by this set of equations and can be solved numerically for any configuration. Unfortunately the complete set contains a large number of parameters and leads to a fifth-order differential equation which cannot be solved analytically. Therefore we will make a number of assumptions which simplify the system considerably, but still contains the basic features: we assume that  $F = 0$ ,  $k_c = k_r = 0$ , and  $f_r = f_c = 0$ . Eliminating all dynamic variables except  $x_c$  and  $x_r$  leads to two differential equations

$$\frac{m_c V_{cd}}{A_c \gamma p_0} \frac{d^3 x_c}{dt^3} + C \frac{A_f}{A_r} \frac{m_c}{A_c} \frac{d^2 x_c}{dt^2} + A_c \frac{dx_c}{dt} = C \frac{m_r}{A_r} \frac{d^2 x_r}{dt^2} + A_d \frac{dx_r}{dt}, \quad (8)$$

with  $V_{c0} + V_{d0} = V_{cd}$ , and

$$\frac{m_c V_{e0}}{A_c \gamma p_0} \left( \frac{A_f}{A_r} - 1 \right) \frac{d^3 x_c}{dt^3} + \frac{T_L}{T_H} C \frac{A_f}{A_r} \frac{m_c}{A_c} \frac{d^2 x_c}{dt^2} = \frac{V_{e0}}{\gamma p_0} \frac{m_r}{A_r} \frac{d^3 x_r}{dt^3} + \frac{T_L}{T_H} C \frac{m_r}{A_r} \frac{d^2 x_r}{dt^2} + A_r \frac{dx_r}{dt}. \quad (9)$$

Now we want to eliminate  $x_r$  in order to obtain a single differential equation in  $x_c$  which determines the whole behavior of the system. This can be done as follows: define the operator

$$O_a = \sum_{i=0}^{N_a} a_i \frac{d^i}{dt^i}. \quad (10)$$

With this operator we can write relations (8) and (9) as  $O_a x_c = O_a x_r$  and  $O_b x_c = O_b x_r$ . The solution is  $O_a O_b x_c = O_b O_a x_c$ . In this way we get, after a rather long but straightforward calculation, a sixth-order differential equation, but the two lowest order terms are zero so the result can be written as a fourth-order differential equation for the piston acceleration  $a_c = d^2 x_c / dt^2$

$$0 = \frac{d^4 a_c}{dt^4} + k_5 \frac{d^3 a_c}{dt^3} + k_4 \frac{d^2 a_c}{dt^2} + k_3 \frac{da_c}{dt} + k_2 a_c. \quad (11)$$

The coefficients are given by

$$k_5 = C \left( \frac{\gamma p_0}{V_{e0}} \frac{T_L}{T_H} + \frac{\gamma p_0}{V_{cd}} \right) \quad (12)$$

$$k_4 = \frac{\gamma p_0 A_r^2}{V_{e0} m_r} + \frac{\gamma p_0 A_c^2}{V_{cd} m_c} + \left( 1 - \frac{A_f}{A_r} \right)^2 \frac{\gamma p_0 A_r^2}{V_{cd} m_r} \quad (13)$$

$$k_3 = \frac{\gamma p_0}{V_{e0}} C \frac{\gamma p_0}{V_{cd}} \left( \frac{A_f A_r}{m_r} \left( 1 - \frac{T_L}{T_H} + \frac{T_L}{T_H} \frac{A_f}{A_r} \right) + \frac{T_L}{T_H} \frac{A_c^2}{m_c} \right) \quad (14)$$

$$k_2 = \frac{\gamma p_0 A_c^2}{V_{cd} m_c} \frac{\gamma p_0 A_r^2}{V_{e0} m_r}. \quad (15)$$

The general solution of Eq.(11) is of the form

$$a_c = C_1 \exp(z_1 t) + C_2 \exp(z_2 t) + C_3 \exp(z_3 t) + C_4 \exp(z_4 t) \quad (16)$$

where  $z_i$  are the roots of the characteristic equation

$$0 = z^4 + k_5 z^3 + k_4 z^2 + k_3 z + k_2 \quad (17)$$

and the values of the constants  $C_i$  follow from the boundary conditions. The coefficients  $k_i$  are real, but, in general, the roots  $z_i$  are complex. The solutions have an oscillating component if the imaginary part of one of the  $z_i$  is nonzero. These oscillations grow in time if the real part is positive and die out if the real part is negative. For stable oscillations the real part is zero and the roots are completely imaginary so  $z = i\omega$  with  $\omega$  the angular frequency of the oscillation. By substituting  $z = i\omega$  in Eq.(17) we get from the real part

$$0 = \omega^4 - k_4\omega^2 + k_2 \quad (18)$$

and from the imaginary part

$$\omega^2 = \frac{k_3}{k_5}. \quad (19)$$

We define a function  $g = k_3^2 - k_3k_4k_5 + k_2k_5^2$  which contains all system parameters and the temperature  $T_L$ . Substitution of Eq.(19) in (18) gives that the oscillation grow if  $g > 0$  and die out if  $g < 0$ . The oscillations are stable if  $g = 0$ . It turns out that the stability condition does not depend on the flow conductance  $C$  of the regenerator. The reason is that the conductance leads to dissipation, so to damping of the oscillations, but, on the other hand, the pressure drop over the regenerator is needed to drive the oscillations. The stability condition gives no information about the amplitude of the oscillations. This has to be obtained from one of the energy flows such as the heating power  $\dot{Q}_L$ .

The function  $g$  contains 11 system parameters and should be investigated in accordance with a particular geometry. In this paper we limit the discussion to some simple cases. In particular it can be derived that no oscillations are possible in an isothermal system ( $g \leq 0$  if  $T_L = T_H$  for all possible system parameters) as it should. The equation  $g = 0$  can be solved e.g. to calculate the temperature where the oscillations start if the temperature is reduced. In the extreme case of  $T_L = 0$  the oscillations tend to grow if

$$0 < \frac{A_c^2 m_r V_{e0}}{m_c A_r^2 V_{cd}} - \frac{A_f}{A_r} \left( 1 + \frac{V_{e0}}{V_{cd}} \left( 1 - \frac{A_f}{A_r} \right) \right) \quad (20)$$

and are stable if the right-hand side is zero. If there is no bouncing volume  $\mathbf{f}$  at all ( $A_f = 0$ ) the system is always unstable. The first term in Eq.(20) can also be written as

$$\frac{\gamma p_0 A_c^2 V_{e0} m_r}{V_{cd} m_c \gamma p_0 A_r^2} = \frac{\omega_c^2}{\omega_r^2} \quad (21)$$

where  $\omega_c = \gamma p_0 A_c^2 / V_{cd} m_c$  ( $\omega_r = \gamma p_0 A_r^2 / V_{e0} m_r$ ) is the resonance frequency of the mass-spring system formed by the piston (regenerator) and the gas spring in the volume  $V_{cd}$  ( $V_e$ ). The oscillation frequency at  $T_L = 0$  is obtained with Eq.(19) and results in  $\omega^2 = A_f \omega_r^2 / A_r$ .

### 3 Conclusion

We have derived a general relation which allows determination of the stability of split-Stirling refrigerators. The relations are rather complex, but can be analyzed easily using analytical programs such as Maple and the like. We have limited the derivation to the special case of zero friction and zero spring constants, but the formalism is general and can be extended to include friction and nonzero spring constants.

### References

- [1] A.T.A.M. de Waele and W. Liang, *Basic Dynamics of Split Stirling Refrigerators*, accepted for publication in Cryogenics.