

Coordination of voltage regulation in active networks

Citation for published version (APA):

Nguyen, H. P., Myrzik, J. M. A., & Kling, W. L. (2008). Coordination of voltage regulation in active networks. In *T&D. IEEE/PES Transmission and Distribution Conference and Exposition, 2008, 21-24 April 2008, Chicago, Illinois* (pp. 1-6). Institute of Electrical and Electronics Engineers. <https://doi.org/10.1109/TDC.2008.4517041>

DOI:

[10.1109/TDC.2008.4517041](https://doi.org/10.1109/TDC.2008.4517041)

Document status and date:

Published: 01/01/2008

Document Version:

Publisher's PDF, also known as Version of Record (includes final page, issue and volume numbers)

Please check the document version of this publication:

- A submitted manuscript is the version of the article upon submission and before peer-review. There can be important differences between the submitted version and the official published version of record. People interested in the research are advised to contact the author for the final version of the publication, or visit the DOI to the publisher's website.
- The final author version and the galley proof are versions of the publication after peer review.
- The final published version features the final layout of the paper including the volume, issue and page numbers.

[Link to publication](#)

General rights

Copyright and moral rights for the publications made accessible in the public portal are retained by the authors and/or other copyright owners and it is a condition of accessing publications that users recognise and abide by the legal requirements associated with these rights.

- Users may download and print one copy of any publication from the public portal for the purpose of private study or research.
- You may not further distribute the material or use it for any profit-making activity or commercial gain
- You may freely distribute the URL identifying the publication in the public portal.

If the publication is distributed under the terms of Article 25fa of the Dutch Copyright Act, indicated by the "Taverne" license above, please follow below link for the End User Agreement:

www.tue.nl/taverne

Take down policy

If you believe that this document breaches copyright please contact us at:

openaccess@tue.nl

providing details and we will investigate your claim.

Coordination of Voltage Regulation in Active Networks

P. H. Nguyen, J. M. A. Myrzik, and W. L. Kling, *Member, IEEE*

Abstract—This paper give an introduction about the Active Network concept that can be managed by a multi-agent system (MAS). Voltage regulation, one of Active Network’s services, is then presented. The autonomous voltage control within each feeder (Cell) can be deployed by a combination of active and reactive power supports of distributed generators (DG). The coordination voltage control defines the optimal tap setting of the on-load tap changer (OLTC) while comparing amounts of control actions in each Cell. The test results show that the voltage regulation in Active Network can help to integrate more DGs and mitigate voltage violation effectively. The optimal solution can be reached within a small number of calculation iterations.

Index Terms—Active Networks (AN), voltage regulation, multi-agent system (MAS), distributed generation (DG), power distribution.

I. INTRODUCTION

THE power delivery system has been changed gradually from the downstream unidirectional scheme to an equally bidirectional scheme due to a large-scale implementation of distributed generation. Consequently, the network needs to be efficient and flexible to cope with arising problems in operation such as bidirectional power flow, voltage rise, short-circuit current increase, or stability issue. The structure of the network should be designed in an adjustable and scalable way for varying needs in the future. Another required characteristic of the network is intelligence, in order to self-adjust and to be adaptable in autonomous operations. Hence, the balancing between supply and demand will be controlled precisely in both normal and disturbance states. Last but not the most important factor is the sustainable criterion that requires concepts and technologies for future grids in social accepted environments.

Regarding these requirements, several promising concepts and technologies for future network are selected and evaluated in [1]. Among them, the Active Network seems to be the most suitable concept, while a Multi-Agent System (MAS) is able to act as a potential control technology to enable that concept. This paper will introduce a detail structure of the Active Network that is managed by MAS technology.

This work is part of the research project: Electrical Infrastructure of the Future (Elektrische Infrastructuur van de toekomst in Dutch), sponsored by the Ministry of Economic Affairs of the Netherlands.

The authors are with the Department of Electrical Engineering, Eindhoven University of Technology, 5600MB Eindhoven, the Netherlands (e-mail: p.nguyen.hong@tue.nl; J.M.A.Myrzik@tue.nl; W.L.Kling@tue.nl).

One of Active Network’s services, the voltage regulation is then presented by a combination of DG’s active and reactive power generation. This control action is implemented autonomously within Cells (feeders) of the Active Network. Furthermore, the cooperation of Cells can alleviate control actions within Cells and approach suitable settings for the on-load tap changer (OLTC).

II. FUTURE POWER DELIVERY SYSTEM

A. Active Networks (AN)

Limitations of the existing distribution network to cope with a large-scale deployment of DGs in the future, led Van Overbeeke and Roberts to propose the vision of “Active Networks” concept as facilitators for DG in [2]. The solution is based on three main points: *interconnection*, *local control areas (cells)*, and *system services*.

While the first point is to provide more than one power flow path, manage congestion by re-routing power and isolate faulted areas effectively, the third point organizes system services and charges to individual customers.

However the most revolution part is proposed in the second point, the local control areas or “Cells”. Hence, one more control level will be installed for each cell component to manage and to control the power inside and across the cell boundaries. It can be deployed with different typical actuators such as voltage and reactive power controllers, FACTS devices, remotely controllable loads and generators.

In fact, the Active Network covers ideas of MicroGrids on low voltage (LV) or Autonomous Controlled parts of medium voltage (MV) networks. However, the Active Network is not only focusing on local areas (cells) but is also concerned with interconnecting between cells and managing the demand side. Therefore, this concept is able to adapt with requirements of sustainability, efficiency, flexibility and intelligence.

The transition to the Active Network does not require an intensive physical change of the existing infrastructure. The most investment is needed for control strategies and communication topologies of the power system [3]. This concept could be considered as a backbone for the future power delivery system.

B. Multi-agent Systems (MAS)

Multi-Agent Systems have been introduced recently as a potential technology for many fields of power system applications. In [4], basic definitions of the MAS concept and its approaches for power application have been presented. The

simplest level of MAS is the “agent” that is defined as an entity (software or hardware) able to work autonomously on a component in the network. The intelligent agent extended from the single agent concept is not only able to react to change in its environment but is also able to interact with other intelligent agents. The MAS concept is a combination of more than one intelligent agent and other agents.

Belonging to the area of computational intelligence, MAS can offer a certain degree of intelligent behaviors in autonomous systems [5]. Different applications of MAS in the power system include disturbance diagnosis, restoration, and protection. Furthermore, power flow management can be implemented based on MAS [6]. Another example is power balancing through an electronic market based on local agents, the so called “Power Matcher” [7].

Important technical issues to implement MAS include platforms and communication languages [4]. In a number of platforms for MAS, the Java Agent Development Framework (JADE) is popular in power engineering applications. However, JADE has some disadvantages in the large-scale implementation. Agent communication languages are set by the Foundation for Intelligent Physical Agents (FIPA) international standard. Other necessary issues are intelligent agent design and data standardization.

C. Constructing Active Networks with support of MAS

The transition from the existing distribution network to the Active Network can start from the traditional radial network concept. The radial network is divided into separate sub networks (feeders). Hence, it is possible to establish a *local control area (cell)* for each feeder. Within a Cell, each controllable component, i.e., controllable generators and loads will have an agent that can operate autonomously with local targets or cooperate with other agents to achieve area tasks. A superior agent is installed for each Cell as a *Moderator* to manage autonomous actions as well as to communicate with other Cells. Communication requirements for the MAS can be a phone-based communication with 56kbaud [8] or the internet-based communication. Fig.1 shows the structure of the Active Network with MAS control in the radial network.

As mentioned before, the Active Network can perform different system services. Under scope of this study, voltage control will be investigated.

III. VOLTAGE REGULATION IN THE ACTIVE NETWORK

Voltage fluctuation is one of the big barriers that mitigate DGs penetration. Main solutions for voltage control problems in a distribution network can be summarized as follows [9]

- Voltage control by the on-load tap changer of the HV/MV transformer (OLTC)
- Reactive power control with DGs and compensators
- DG active power control

Many works have been implemented to quantify suitable solutions that facilitate connecting more DGs. Some works focus on intelligent control of the HV/MV transformer [10-12]. Alternative approaches concern local voltage control at DG’s connecting point [13; 14]. An evaluation of different control solution has been presented in [15]. In [16],

centralized and local voltage controls are compared in detail. Centralized voltage control based on an active management scheme that first estimates the power system state by several measurement equipments, and then dispatches DGs according to the OPF. Local voltage control is deployed by combining automatic voltage regulation (AVR) and power factor control (PFC) of DGs.

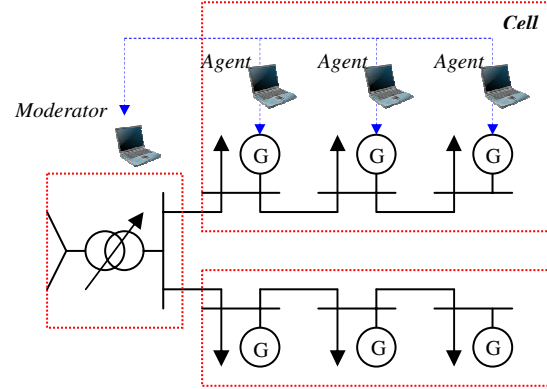

Fig.1. Active Network managed by MAS

In this paper, another approach to coordinate voltage regulation by cell-based theory and multi-agent technology is presented.

A. Active and reactive power control

The sensitivity of bus voltages due to the changes of active and reactive power generation can be represented by the linear equations as follows:

$$\begin{bmatrix} \Delta P \\ \Delta Q/V^0 \end{bmatrix} = \begin{bmatrix} J_{p\theta} & J_{pv} \\ J_{q\theta} & J_{qv} \end{bmatrix} \begin{bmatrix} \Delta\theta \\ \Delta V \end{bmatrix} \quad (1)$$

Due to the fact that MV networks may include mainly cable lines with a relative high R/X ratio, (1) is impossible to be decoupled with the assumptions that ΔP is more sensitive to the $\Delta\theta$, and ΔQ is more sensitive to the ΔV .

However, the effect of active and reactive power generation change to bus voltages can be considered separately from (1) by the equations:

$$\Delta P = [J_{pv} - J_{p\theta} J_{q\theta}^{-1} J_{qv}] \Delta V = [A] \Delta V \quad (2)$$

and,

$$\Delta Q/V^0 = [J_{qv} - J_{q\theta} J_{p\theta}^{-1} J_{pv}] \Delta V = [B] \Delta V \quad (3)$$

These equations stand for the capability of DG in the MV network to contribute to voltage regulation by varying active and reactive power generation.

The relationship between the bus voltage and reactive power generation has been mentioned in [8]. With the assumption that the power load and active power output of the DGs will not change, (3) can be rewritten as follows:

$$\begin{bmatrix} 0 \\ \Delta Q_g/V_g^0 \end{bmatrix} = \begin{bmatrix} C_{11} & C_{12} \\ C_{21} & C_{22} \end{bmatrix} \begin{bmatrix} \Delta V_L \\ \Delta V_g \end{bmatrix} \quad (4)$$

$$\text{Hence, } \Delta V_g = [D]\Delta Q_g / V_g^0 \quad (5)$$

$$\text{where } D = [C_{21}C_{11}^{-1}C_{12} - C_{22}]^{-1} \quad (6)$$

Using (6), a reactive power sensitive factor β_j is determined as

$$\beta_j = D_{ij} / V_j^0 \quad (7)$$

that presents voltage sensitivity of bus i with reactive power output change of generator j . The bus voltages therefore can be controlled by a reactive power dispatch based on ranking of the sensitive factors β_j .

Similarly, the relationship between the bus voltages and active power generation change can be possibly established. This control action occurs when the reactive power generated by the DGs reaches the limit. While $\Delta Q = 0$, active power change will be obtained from (2) as follows:

$$\begin{bmatrix} 0 \\ \Delta P_g \end{bmatrix} = \begin{bmatrix} E_{11} & E_{12} \\ E_{21} & E_{22} \end{bmatrix} \begin{bmatrix} \Delta V_L \\ \Delta V_g \end{bmatrix} \quad (8)$$

$$\text{Hence, } \Delta V_g = [F]\Delta P_g \quad (9)$$

$$\text{where } F = [E_{21}E_{11}^{-1}E_{12} - E_{22}]^{-1} \quad (10)$$

Using (10), an active power sensitive factor γ_j is determined as

$$\gamma_j = E_{ij} \quad (11)$$

Consequently, the active power dispatch by comparing sensitive factors γ_j can also control the bus voltages.

Voltage control using reactive power generation has some disadvantages to regulate the bus voltage at the end of the feeder in case of voltage drops. It often requires generating great amounts of reactive power that might be out of generators' limits. While the active power dispatch scheme can only cope with voltage rises when active power output can only be curtailed. Therefore, the combination of active and reactive power dispatch schemes may be a better solution that can deal with different kinds of voltage changes.

In order to integrate active and reactive power dispatches, a comparative relationship between MW and MVar change should be considered. Thus, weighting factors w_p and w_Q are introduced as a proportion of cost for curtailing 1MW and generating (absorbing) 1MVar. The optimization problem for voltage regulation can be written as follows:

$$\text{Min } f = \sum_{j=1}^m (w_p \Delta P_{gj} + w_Q \Delta Q_{gj}) \quad (12)$$

$$\text{s.t } \sum_{j=1}^m (\gamma_j \Delta P_{gj} + \beta_j \Delta Q_{gj} / V_{gj}^0) = \Delta V_i$$

$$P_{gj}^{\min} \leq P_{gj}^0 + \Delta P_{gj} \leq P_{gj}^{\max}$$

$$Q_{gj}^{\min} \leq Q_{gj}^0 + \Delta Q_{gj} \leq Q_{gj}^{\max} \quad j = 1..m$$

where m is the number of DGs in the feeder; Q_{gj} , Q_{gj}^{\min} , and Q_{gj}^{\max} are reactive power outputs and its limit for each DG; P_{gj} , P_{gj}^{\min} , and P_{gj}^{\max} are real power outputs and its limit for each DG.

B. Autonomous voltage control in Cells

When voltage violation occurs within a Cell, an autonomous voltage control algorithm can be implemented as follows:

1. The *moderator* sends a Request for Proposal (RFP) message to every DG agent. Content of the message includes the desired voltage change ΔV_i and control bus i .
2. After receiving RFP, each DG agent A_j updates the value of the sensitive factors β_j and γ_j that can be calculated from (7) and (11). Although each DG can change both real and reactive power output, only one scheme is applied due to the assumption of considering P_g and Q_g separately. Therefore, the comparison of w_Q/β_j and w_P/γ_j is needed to point out the economic control action. The DGs respond message to the *moderator* including identification of 1- reactive power control or 2- real power control, current Q (P) outputs, and its limits.
3. The *moderator* decides the dispatch order of DGs based on comparing ratios of the weighting factors to the sensitive factors.

This process is repeated until the ΔV_i is less than ε (0.001) or DGs real and reactive power outputs both reach their limit. Voltage control coordination with the OLTC and other Cells can be implemented in the next step to achieve better results.

C. Voltage control coordination

It has been known that OLTC is the most effective way to control voltage in distribution networks. However, with a large number of DGs, it is a difficult task to reach optimal setting points of the OLTC, especially when the HV/MV transformer is connected with a certain generation feeder and other load feeders.

This work proposes a searching method to obtain the setting point of the OLTC comparing the amounts of control actions in the Cells (outgoing feeders). The control algorithm can be implemented by MAS supporting as follows:

1. The *moderator* of Cell where a voltage violation occurs (M_i) sends a RFP message to other Moderators (M_j). Content of the message requires the calculation of the amounts of autonomous control actions (A_j) if there is any voltage violation within them.
2. M_i collects the total amount of control actions (A_{Σ}) including A_i to compare with the total amount of previous tap settings (A_{Σ}^0). If there is no previous setting or ($A_{\Sigma} < A_{\Sigma}^0$) then move to Step 3. Otherwise, the optimal solution is the previous tap setting and the progress is stopped.
3. If a voltage rise occurs in Cell i then the tap setting = tap setting + 1; else the (voltage drop) tap setting = tap setting - 1. M_i then sends a RFP message to the HV/MV transformer to realize the new setting point.
4. If, after the OLTC has moved to the new setting point, a voltage violation occurs in the Cells then the voltage is controlled autonomously within the Cells. Repeating with step 1.

IV. SIMULATIONS

The test system is a typical medium voltage grid in Netherlands as in Fig.2. The network includes two feeders which can be connected by a normal-open point (NOP). Generation and load buses are shown in Table 1.

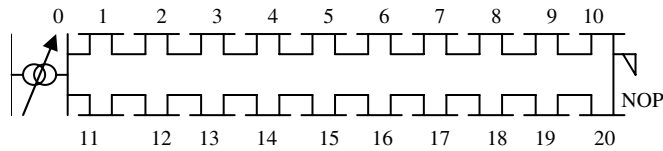

Fig.2. Model of medium voltage feeders

TABLE I
GENERATION AND LOAD DATA

| Bus | Feeder 1 | | | | Feeder 2 | | | |
|-------|----------|-------|-------|-------|----------|-------|-------|-------|
| | P_g | Q_g | P_L | Q_L | P_g | Q_g | P_L | Q_L |
| 1/11 | 3 | 0 | 1 | 0.48 | | | 1 | 0.48 |
| 2/12 | 3 | 0 | 1 | 0.48 | | | 1 | 0.48 |
| 3/13 | 3 | 0 | 1 | 0.48 | 3 | 0 | 1 | 0.48 |
| 4/14 | 3 | 0 | 1 | 0.48 | | | 1 | 0.48 |
| 5/15 | 3 | 0 | 1 | 0.48 | 3 | 0 | 1 | 0.48 |
| 6/16 | 3 | 0 | 1 | 0.48 | | | 1 | 0.48 |
| 7/17 | 3 | 0 | 1 | 0.48 | 3 | 0 | 1 | 0.48 |
| 8/18 | | | 1 | 0.48 | | | 1 | 0.48 |
| 9/19 | | | 1 | 0.48 | 3 | 0 | 1 | 0.48 |
| 10/20 | | | 1 | 0.48 | | | 1 | 0.48 |

Other network information:

- HV/MV transformer: OLTC $\pm 5\%$, tap 2.5% .
- Line section: $r = 0.25\text{p.u.}$, $x = 0.178\text{p.u.}$, and $b = 0.00033\text{p.u.}$
- Generator: $P_{\max} = 3\text{MW}$; $P_{\min} = 30\%P_{\max}$; $\cos\phi_{\text{ind}} = 0.95$; $\cos\phi_{\text{cap}} = 0.9$.
- Ratio of weighting factors $w_P/w_Q = 2$.

The initial point of the OLTC is set at $V_{\text{ref}} = 1\text{p.u.}$ Voltage profiles of two feeders are shown in Fig.3. The bus voltages are all in the acceptable range.

The two studied scenarios are: a voltage rise when more generators (G8) are installed in the feeder 1 and a voltage drop when one generator (G19) is out of service in the feeder 2. As can be seen in Fig. 3, voltage violations occur in both cases. Voltage regulation actions will be applied to reject these problems.

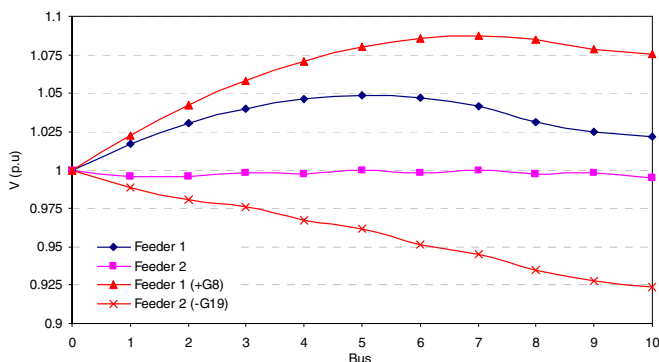

Fig.3. Voltage scheme without control actions

A. Voltage rise

In this case, the voltage control will facilitate the network to integrate more DGs at buses of the end of the feeder 1 (G8,

G9, and G10) without any voltage exceeding. Fig. 4 shows the increase of the feeder voltage when more DGs are connected (dashed lines). After the autonomous voltage control process, bus voltages are in the acceptable range (continuous lines).

Table 2 shows the power generation dispatch of DGs to adapt with voltage rise. When generator at bus 8 (G8) is connected, only the reactive power dispatch is applied for G5, G6, G7, and G8. However, when G9 is connected, there is a comparison of w_Q/β_4 and w_P/γ_9 . Because of a less value, the active power curtailment of G9 is selected. Similarly, installing G10 leads to curtail the active power of G10 and G9.

Regarding these results, the combination of active and reactive power support can cope with voltage rise at the end of the feeder effectively. A suitable amount of active power is curtailed instead of much greater amount of reactive power absorbing. It depends on the comparison of sensitive factors at the generation buses and the ratio of the weighting factors. Locations of curtailed generators are quite near to the violated voltage bus what makes control actions more sensitive.

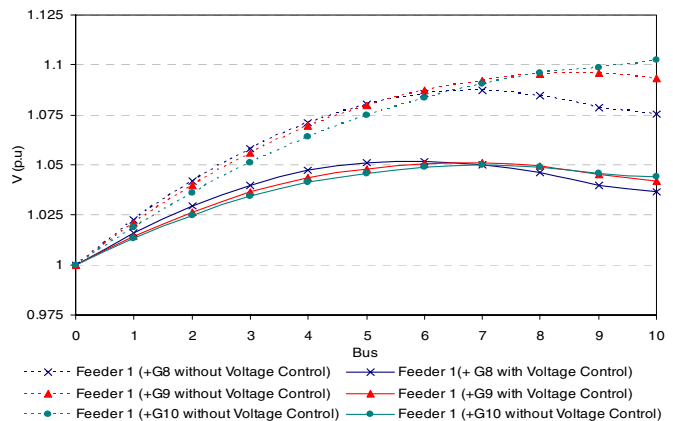

Fig.4. Effect of autonomous voltage control in case of voltage rise

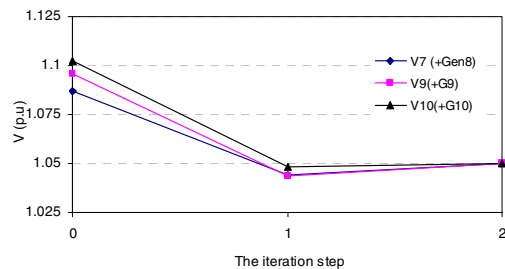

Fig.5. Convergence in case of voltage rise

TABLE II
POWER GENERATION DISPATCH

| | G8 | | G9 | | G10 | |
|-------|----|---------|--------|---------|--------|---------|
| | MW | Mvar | MW | Mvar | MW | Mvar |
| Gen 1 | 3 | 0 | 3 | 0 | 3 | 0 |
| Gen 2 | 3 | 0 | 3 | 0 | 3 | 0 |
| Gen 3 | 3 | 0 | 3 | 0 | 3 | 0 |
| Gen 4 | 3 | 0 | 3 | 0 | 3 | 0 |
| Gen 5 | 3 | -0.0840 | 3 | -0.9367 | 3 | -0.9367 |
| Gen 6 | 3 | -0.9367 | 3 | -0.9367 | 3 | -0.9367 |
| Gen 7 | 3 | -0.9367 | 3 | -0.9367 | 3 | -0.9367 |
| Gen 8 | 3 | -0.9367 | 3 | -0.9367 | 3 | -0.9367 |
| Gen 9 | - | - | 1.6365 | -0.9367 | 1.4271 | -0.9367 |

| | | | | | | |
|--------|---|---|---|---|-----|---------|
| Gen 10 | - | - | - | - | 1.2 | -0.9367 |
|--------|---|---|---|---|-----|---------|

In addition, these control actions can give converged solution within two steps, as can be seen from Fig.5. The remarkable result opens possibility to implement this technique in real-time (on-line) application.

B. Voltage drop

Due to a contingency, G19 in the feeder 2 is out of service. Remaining DGs will coordinate to keep the bus voltages in the acceptable range. As it is impossible to generate more active power of DGs, only the reactive power control scheme is used in this case.

After two steps, all bus voltages of feeder 2 are within the acceptable range. Gen 15 generates 0.7041MVar while Gen 17 has to produce the maximum amount of reactive power generation (1.3MVar). Voltage profile of feeder 2 for each control step is shown in Fig. 6.

C. Voltage control coordination

Voltage rise due to connecting more DGs in the feeder 1 will be reinvestigated with the voltage control coordination. Voltage profiles of both feeders in the different cases are shown in Fig.7. Table III summarizes results of total DGs active and reactive power output changes in the two feeders as well as the tap position when installing G8, G9, and G10.

As can be seen from Table III, installing G8 with the voltage coordination can reduce dramatically the amount of control actions (ΔQ). In this case, the tap setting will move to the position 1 without any voltage violation of the feeder 2. When G9 is connected, the voltage control coordination compares the total amount of control actions in case of autonomous dispatch in the feeder 1, no voltage violation in the feeder 2, tap position 1 and in case of autonomous control in both feeders, leading to tap position 2. As the second case requires more control actions, the first case is selected for coordination. Similarly, installing G10 with voltage control coordination tap position 2 is selected and autonomous control is required in both feeders.

As an alternative to centralized voltage control, this coordination might approach the optimal solution. In the further work, it will be compared with the OPF results that have been mentioned in [16]. Other voltage control techniques such as line drop compensation (LDC) or line voltage regulator (VR) will also be considered.

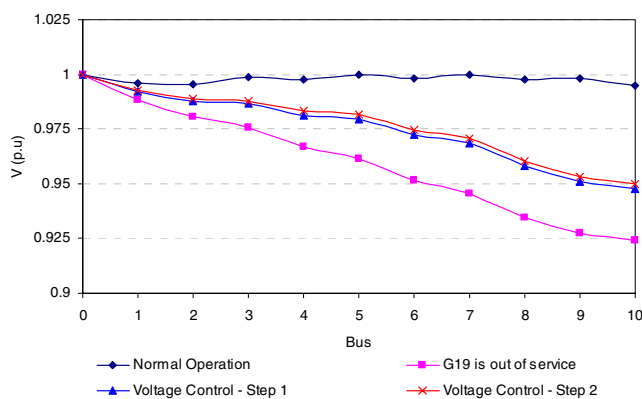

Fig.6. Effect of autonomous voltage control in case of a voltage drop

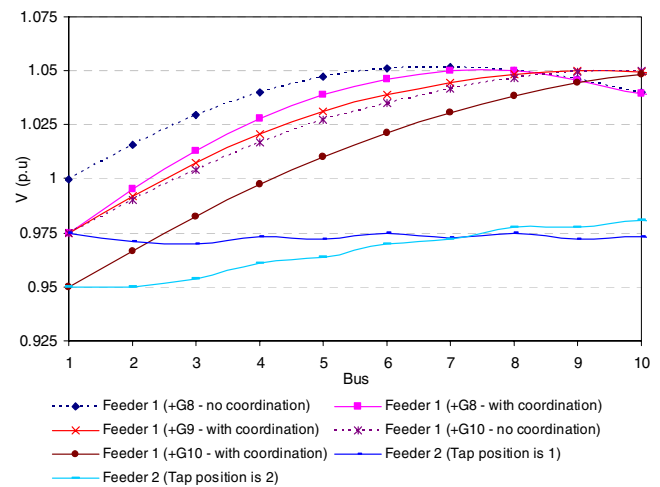

Fig.7. Effect of voltage control coordination

TABLE III
POWER GENERATION DISPATCH

| Cases | Feeder 1 | | Feeder 2 | | Tap |
|-------------------------|--------------|--------------|--------------|--------------|-----|
| | ΔP_1 | ΔQ_1 | ΔP_2 | ΔQ_2 | |
| G8 - no coordination | - | 2.8940 | - | - | 0 |
| G8 - with coordination | - | 1.0123 | - | - | 1 |
| G9 - no coordination | - | 4.3719 | - | - | 1 |
| G9 - with coordination | - | 4.3719 | - | - | 1 |
| G10 - no coordination | 1.7298 | 5.6202 | - | - | 1 |
| G10 - with coordination | 0.3550 | 5.6202 | - | 2.0201 | 2 |

V. CONCLUSION

The introduction of active elements in distribution networks can provide an efficient, flexible and intelligent approach to overcome problems in future circumstances with large amounts of DG. In order to enable the Active Network concept, MAS is a promising technology. It has been investigated by providing one of Active Network's services, voltage regulation.

In this paper, voltage regulation is firstly implemented within each control area called Cell by DG's active and reactive power support. The combination of active and reactive power dispatch can give a robust solution for each Cell by defining ratio of sensitive factors and weighting factors. Coordination between feeder Cells and HV/MV transformer based on comparing amounts of control actions will lead to an optimal operation of the distribution network.

VI. REFERENCES

- [1] P.H.Nguyen, W.L.Kling and M.J.A.Myrdzik, "Promising concepts and technologies for future power delivery systems", UPEC2007 - University's Power Engineering Conference, Brighton, UK, 2007.
- [2] F. van Overbeeke and V. Roberts, "Active networks as facilitators for embedded generation", *Cogeneration and On-Site Power Production* 3[2], 2002.
- [3] P.Lund, O.Mogstad, V.Neimane, A.Pleym and O.Samuelsson, "Connection of distributed generation - effect on the power system", TR A5785 EBL-K 114-2003. 2003.
- [4] S.D.J.McArthur and E.M.Davidson, "Concepts and approaches in multi-agent systems for power applications", *Intelligent Systems Application to Power Systems*, May 2005.

- [5] C.Rehtanz, *Autonomous Systems and Intelligent Agents in Power System Control and Operation*, Springer, 2003.
- [6] A.Korbik, S.D.J.McArthur, G.W.Ault, G.M.Burt, and J.R.McDonald, "Enabling active distribution networks through decentralised autonomous network management," in Proc. *18th International Conference and Exhibition on Electricity Distribution*, Stevenage, UK 2006.
- [7] CRISP - Critical Infrastructures for Sustainable Power, EU-EESD project No.ENK5-CT-2002-00673, 2006.
- [8] M.E.Baran and I.M.E. Markabi, "A Multiagent-Based Dispatching Scheme for Distributed Generators for Voltage Support on Distribution Feeders", *IEEE Transactions on Power Systems*, vol. 22, no. 1, pp. 52-59, 2007.
- [9] A.Collinson, F.Dai, A.Beddoes and J.Crabtree, "Solutions for the connection and operation of distributed generation", K/EL/00303/00/01/REP URN 03. 2003.
- [10] F.Provoost, M.J.A. Myrzik, and W.L. Kling, "Intelligent limiting voltage variations in autonomously controlled networks", in Proc. *19th International Conference on Electricity Distribution – CIGRE*, Vienna 2007.
- [11] M. Thomson, "Automatic voltage control relays and embedded generation. I", *Power Engineering Journal [see also Power Engineer]*, vol. 14, no. 2, pp. 71-76, 2000.
- [12] F.A.Viawan, A.Sannino, and J.Daalder, "Voltage control with on-load tap changers in medium voltage feeders in presence of distributed generation", *Electric Power Systems Research*, vol. 77 pp. 1314-1322, 2007.
- [13] E. F. Mogos and X. Guillaud, "A voltage regulation system for distributed generation", in Proc. *Power Systems Conference and Exposition IEEE PES*, 2004.
- [14] P.N.Vovos, A.E.Kiprakis, P.Harrison, and J.R.Barrie, "Intelligent limiting voltage variations in autonomously controlled networks", in Proc. *18th International Conference on Electricity Distribution – CIGRE*, Turin 2005.
- [15] S. N. Liew and G. Strbac, "Maximising penetration of wind generation in existing distribution networks", *Generation, Transmission and Distribution, IEE Proceedings*, vol. 149, no. 3, pp. 256-262, 2002.
- [16] P. N. Vovos, A. E. Kiprakis, A. R. Wallace, and G. P. Harrison, "Centralized and Distributed Voltage Control: Impact on Distributed Generation Penetration", *IEEE Transactions on Power Systems*, vol. 22, no. 1, pp. 476-483, 2007.



Prof. W. L. Kling received his M.Sc. degree in electrical engineering from the Technical University of Eindhoven, The Netherlands, in 1978. Since 1993, he is a part-time Professor at the Electric Power Systems Laboratory, Delft University of Technology, Delft, The Netherlands. And since 2000, also at the Eindhoven University of Technology. Furthermore he is with TenneT, the Dutch Transmission System Operator, in the Asset Management Department responsible for network strategy. His experience is in the area of planning and operation of power systems. Prof. Kling is involved in scientific organizations such as Cigré and IEEE. He is the Dutch Representative in the Cigré Study Committee C6 Distribution Systems and Dispersed Generation and the Eurelectric/UCTE WG SYSTINT.

VII. BIOGRAPHIES

Phuong H. Nguyen was born in Hanoi, Vietnam in 1980. He received his MEng. in Electrical Engineering from the Asian Institute of Technology, Thailand in 2004. From 2004 to 2006 he worked as a researcher at the Power Engineering Consulting Company 1, Electricity of Vietnam. In the end of 2006 he joined the Electrical Power System Research group at Eindhoven University of Technology, the Netherlands as a Phd student. He is working under the framework of the "Electrical Infrastructure of the Future" project.



Johanna M.A. Myrzik was born in Darmstadt, Germany in 1966. She received her MSc. in Electrical Engineering from the Darmstadt University of Technology, Germany in 1992. From 1993 to 1995 she worked as a researcher at the Institute for Solar Energy Supply Technology (ISET e.V.) in Kassel, Germany. In 1995 Johanna joined to the Kassel University, where she finished her PhD thesis in the field of solar inverter topologies in 2000. Since 2000, Johanna is with the Eindhoven University of Technology, the Netherlands. In 2002, Johanna became an assistant professor in the field of distributed generation. Her fields of interests are: power electronics, renewable energy, distributed generation, electrical power supply.

