

Transmission of 10 Gb/s per wavelength in a hybrid WDM/TDM access network providing bandwidth on-demand

Citation for published version (APA):

Urban, P. J., Huijskens, F., Khoe, G. D., Koonen, A. M. J., & Waardt, de, H. (2009). Transmission of 10 Gb/s per wavelength in a hybrid WDM/TDM access network providing bandwidth on-demand. In M. Jaworski (Ed.), *Proceedings of the 11th international conference on transparent optical networks (ICTON 2009) 28 June - 07 July 2009, Ponta Delgada, Island of São Miguel, Azores, Portugal* (pp. Tu.C5.6-1/3). Institute of Electrical and Electronics Engineers. <https://doi.org/10.1109/ICTON.2009.5185128>

DOI:

[10.1109/ICTON.2009.5185128](https://doi.org/10.1109/ICTON.2009.5185128)

Document status and date:

Published: 01/01/2009

Document Version:

Publisher's PDF, also known as Version of Record (includes final page, issue and volume numbers)

Please check the document version of this publication:

- A submitted manuscript is the version of the article upon submission and before peer-review. There can be important differences between the submitted version and the official published version of record. People interested in the research are advised to contact the author for the final version of the publication, or visit the DOI to the publisher's website.
- The final author version and the galley proof are versions of the publication after peer review.
- The final published version features the final layout of the paper including the volume, issue and page numbers.

[Link to publication](#)

General rights

Copyright and moral rights for the publications made accessible in the public portal are retained by the authors and/or other copyright owners and it is a condition of accessing publications that users recognise and abide by the legal requirements associated with these rights.

- Users may download and print one copy of any publication from the public portal for the purpose of private study or research.
- You may not further distribute the material or use it for any profit-making activity or commercial gain
- You may freely distribute the URL identifying the publication in the public portal.

If the publication is distributed under the terms of Article 25fa of the Dutch Copyright Act, indicated by the "Taverne" license above, please follow below link for the End User Agreement:

www.tue.nl/taverne

Take down policy

If you believe that this document breaches copyright please contact us at:

openaccess@tue.nl

providing details and we will investigate your claim.

Transmission of 10 Gb/s per Wavelength in a Hybrid WDM/TDM Access Network Providing Bandwidth on-demand

P. J. Urban, F. M. Huijskens, G. D. Khoe, A. M. J. Koonen, and H. de Waardt
 COBRA Institute, Eindhoven University of Technology, Eindhoven, the Netherlands
 e-mail: P.J.Urban@tue.nl

ABSTRACT

In this paper we describe experiments performed on a testbed of a novel dynamically reconfigurable access network capable of providing bandwidth on-demand to the end-users. Multiwavelength bidirectional transmission of 10 Gb/s channels in different bandwidth allocation schemes is achieved while sustaining substantial power budget to cover the attenuation of over 25 km standard SMF and related power penalties e.g. due to Rayleigh backscattering.

Keywords: reconfigurable access network, FTTx, reflective electro-absorption modulator, optical add/drop multiplexer, microring resonators.

1. INTRODUCTION

As the fiber links are being pushed closer to users' premises providing the capability of large amount of data being transmitted downstream and upstream, the traffic has to be managed in a bandwidth- and cost-efficient manner in order to satisfy both the end-users' and network operators' demands.

The Broadband Photonics Access network (BBPhotonics) presented here provides high bandwidth on-demand thanks to such elements as an optical add/drop multiplexer (OADM) [1] and a colorless optical network unit (ONU) [2]. The mentioned elements can be integrated which enables cost-efficient mass production. The OADM provides remote network reconfiguration as a result of wavelength channels switching. The ONU enables centralized light generation and remote continuous wavelength (CW) modulation. On/off keying (OOK) is applied in both directions which requires simple direct receivers. The detailed description of the BBPhotonics architecture is given in [3] and the preliminary experiments in [4].

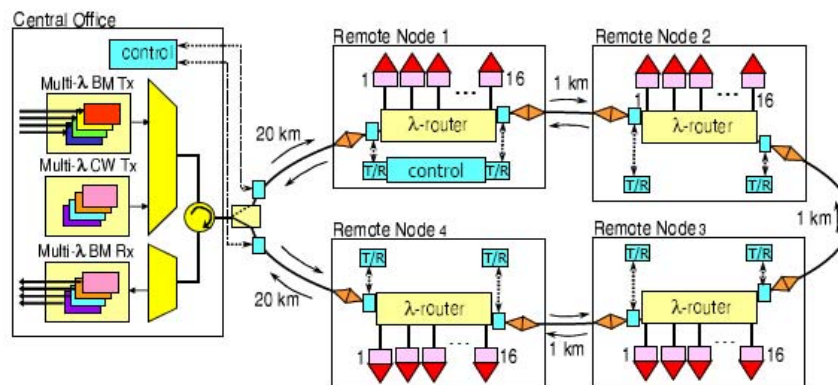

Figure 1. BBPhotonics access network architecture.

The network connects 64 ONUs. There are four remote nodes (RNs) which are connected by a standard single mode fiber (SSMF) to a central office (CO), Fig. 1. The CO transmits 8 FSR-coupled data and CW wavelength pairs, where FSR is the free spectral range of the OADM equal to an integer multiple of 50 GHz (standard ITU wavelength channel interval). The downstream (DS) data channel, which is amplitude modulated with NRZ code, contains the data to be received by the user. The DS CW is a carrier to be modulated with upstream (US) data transmitted from the end-user side. Such wavelength channel pair is dropped at a single drop port of the OADM, Fig 2c. For protection function a switch is placed at the CO and its state depends on the point of a fiber break in the ring. For network management 100Base-X protocol is used [5] and the control channel on 1310/1490 nm is coupled into the ring via CWDM mux at the CO and each RNs.

The wavelength switching in the RN is provided by means of the OADM, which is an integrated structure of individually controlled thermally tunable micro-ring resonators. An example of 8-port OADM is given in Fig. 2a. The temperature dependency of the refractive index is used to apply a phase shift to the optical field and as a result tune the resonant frequency of a given ring and, therefore, change the wavelength channel being dropped to the output port. The time required to switch from one wavelength channel to another spaced by 50 GHz is 6 ms. This is measured at maximum correctly received UDP packets. It is not critical even for real-time applications i.e. VoIP, where packets contain 10–20 ms of voice data [6]. Using the OADM a single wavelength pair can be dropped to one (PtP) or multiple users (TDM-PON). PtMP scheme is achieved by

detuning a ring with 5 – 10 GHz from the broadcast wavelength channel which results in drop-and-continue operation of the ring.

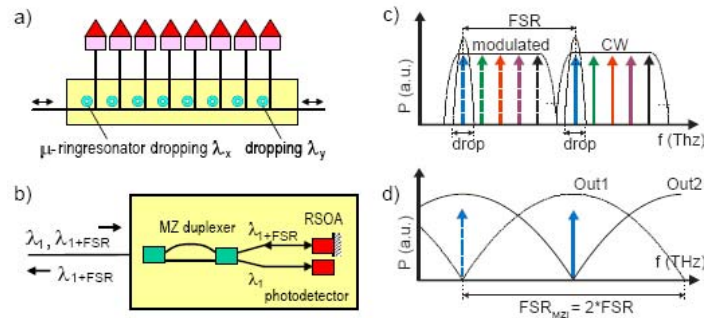

Figure 2. Architecture of a) OADM and b) ONU and corresponding wavelength panels c) and d).

The integrated ONU, Fig. 2b, contains a tunable Mach-Zehnder interferometer (MZI) with FSR equal to the double FSR of the OADM, Fig. 2d. That way, any FSR-coupled channels are decoupled at the two outputs of the MZI. The ONU contains also a photodetector to receive the DS signal and a semiconductor optical amplifier-reflective electro-absorption modulator (SOA-REAM) to modulate, amplify and transmit the US (NRZ) signal. The SOA-REAM can operate in complete C-band because of its broad optical bandwidth.

2. TESTBED

The experimental testbed is shown in Fig. 3. The CO consists of four lasers generating λ_1 , $\lambda_1 + FSR$, λ_2 and $\lambda_2 + FSR$, Fig. 4. λ_1 and λ_2 are amplitude-modulated with 10 Gb/s DS data in an MZI modulator. The channels are coupled into the feeder fiber by a 4:1 coupler and a circulator. The receiver part of the headend consists of a tunable filter (required due to the FSR of the OADM, which is unintentionally not an integer multiple of the ITU-T wavelength grid channel interval), step attenuator for bit error rate (BER) measurement, 90/10 splitter for received optical power (ROP). The losses in the attenuators inserted between CO and RN and later between RN and ONU correspond to the losses of the fiber-spans of 25 km and 1 km, which is 5 dB and 0.2 dB, respectively.

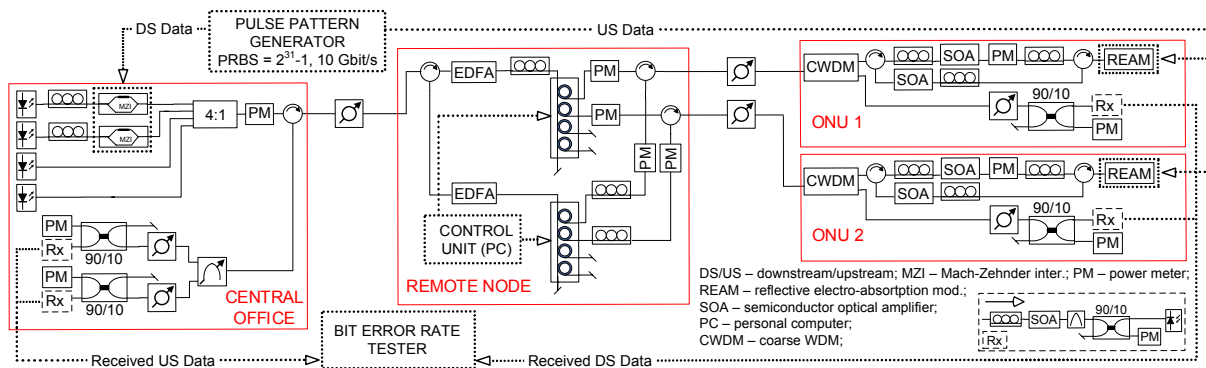

Figure 3. BBPhotonics experimental testbed.

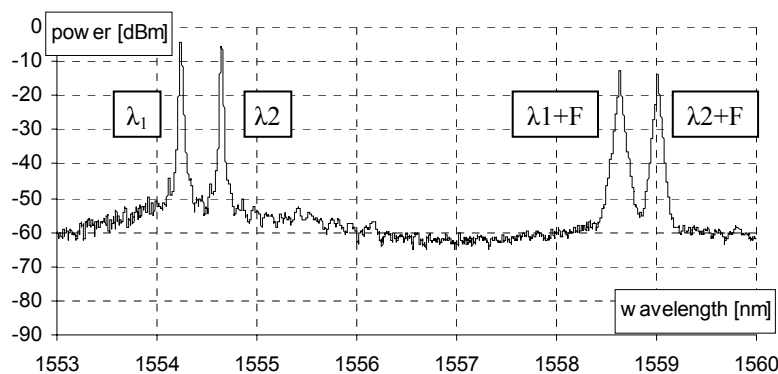

Figure 4. WDM signal transmitted from CO.

3. RESULTS AND DISCUSSION

Fig. 5 shows results obtained during transmission experiments on the testbed presented in Fig. 3. The transmission properties were examined under the conditions of two different wavelength allocation schemes (PtP, PtMP) which prove the capability of dynamic reconfiguration of the network. In PtP case ONU#1 works on λ_1 and $\lambda_{1+\text{FSR}}$ whereas ONU#2 works on λ_2 and $\lambda_{2+\text{FSR}}$. In PtMP case ONU#1 and ONU#2 share λ_1 and $\lambda_{1+\text{FSR}}$. Two reference measurements were taken for the DS RX for λ_1 and λ_2 .

For PtP case there is 1 dB PP in a DS BtB which is assigned to the polarization instability and the misalignment of the optical filters. For PtP BtB US the main source of PP is the coherent intrachannel crosstalk caused by the imperfect suppression (20 dB) of the drop channels of the OADM resulting in the SCR of 20 dB and PP=2 dB for each ONU. A significant contribution to the total PP brings lower extinction ratio (ER) of the REAM (ONU#1 ER = 10 dB and ONU#2 ER = 7.5 dB) with respect to the reference modulator (12 dB) which gives 0.7 dB and 1.5 dB PP for ONU#1 and ONU#2, respectively. The other distortions are the ASE noise accumulation in the complete DS CW transmission (EDFA, SOA) and US data transmission (SOA, EDFA, SOA), polarization instability and optical filters misalignment (total 2.0 dB).

During the PtMP measurement to simulate TDM one ONU was working at a time while the other one had the SOA and REAM biases set to 0 V. For DS transmission the ~3 dB multicast loss in the OADM was covered with the available power budget and no significant difference in BER vs. ROP was observed. For US lower CW power injected into the ONU caused lower extinction ratio (0.8 dB) and therefore additionally increased the PP.

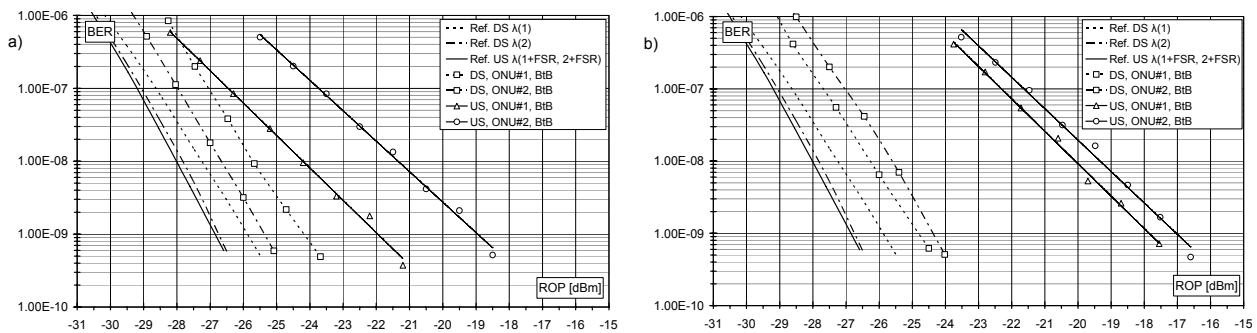

Figure 5. Results for a) PtP and b) PtMP configuration.

4. CONCLUSIONS

Multiwavelength bidirectional transmission of 10 Gb/s wavelength channels in different bandwidth allocation schemes is achieved while reserving substantial power budget able to cover the attenuation of over 25 km standard SMF and related power penalties e.g. due to Rayleigh backscattering.

ACKNOWLEDGEMENTS

This work is part of the Freeband BB Photonics project (<http://bbphotonics.freeband.nl>). Freeband is sponsored by the Dutch Government under contract BSIK 03025.

REFERENCES

- [1] E. J. Klein, P. J. Urban, G. Sengo, L. T. H. Hilderink, M. Hoekman, R. Pellens, P. van Dijk, A. Driessen, Densely integrated microring resonator based photonic devices for use in access networks, *Optics Express*, vol. 15, no. 16, Aug. 2007, pp. 10346-10355.
- [2] L. Xu, X. J. M. Leijtens, P. J. Urban, E. Smalbrugge, T. de Vries, R. Nötzel, Y. S. Oei, H. de Waardt, InP-based monolithic integrated colorless reflective transceiver, in *Proc. ECIO, 2008*, Eindhoven, paper FrPD4, pp. 13-16.
- [3] P. J. Urban, B. Huiszoon, R. Roy, M. M. de Laat, F. M. Huijskens, G. D. Khoe, A. M. J. Koonen, H. de Waardt, High bit rate dynamically reconfigurable WDM/TDM access network, *J. Optical Commun. and Netw.*, to be published 07/2009.
- [4] P. J. Urban, M. M. de Laat, F. M. Huijskens, G. D. Khoe, A. M. J. Koonen, H. de Waardt, 1.25 Gb/s transmission over an access network link with tunable OADM and a reflective SOA, *Photonics Techn. Letters*, vol. 21, no. 6, Mar. 2009, pp. 380-382.
- [5] R. Roy, G. Manhoudt, W. van Etten, Bandwidth re-distribution techniques for extended EPON based multi-wavelength networks, in *Proc. ICTON, 2007*, Rome, paper Mo.P.21.
- [6] P. J. Urban, M. M. de Laat, E. J. Klein, A. M. J. Koonen, G. D. Khoe, H. de Waardt, 1.25 Gbit/s bidirectional link in an access network employing a reconfigurable optical add/drop multiplexer and a reflective semiconductor optical amplifier, in *Proc. ICTON, 2008*, Athens, paper We.B4.5.