

# Effect of grid disturbances on fault-ride-through behaviour of MV-connected DG-units, in especially CHP-plants

**Citation for published version (APA):**

Coster, E. J., Myrzik, J. M. A., & Kling, W. L. (2009). Effect of grid disturbances on fault-ride-through behaviour of MV-connected DG-units, in especially CHP-plants. In *Proceedings of the Joint Symposium Integration of Wide-Scale Renewable Resources into the Power Delivery System (CIGRE/PES 2009 C6)*, 29-31 July 2009, Calgary Albany, Canada (pp. 5211189-1/11). Institute of Electrical and Electronics Engineers.

**Document status and date:**

Published: 01/01/2009

**Document Version:**

Publisher's PDF, also known as Version of Record (includes final page, issue and volume numbers)

**Please check the document version of this publication:**

- A submitted manuscript is the version of the article upon submission and before peer-review. There can be important differences between the submitted version and the official published version of record. People interested in the research are advised to contact the author for the final version of the publication, or visit the DOI to the publisher's website.
- The final author version and the galley proof are versions of the publication after peer review.
- The final published version features the final layout of the paper including the volume, issue and page numbers.

[Link to publication](#)

**General rights**

Copyright and moral rights for the publications made accessible in the public portal are retained by the authors and/or other copyright owners and it is a condition of accessing publications that users recognise and abide by the legal requirements associated with these rights.

- Users may download and print one copy of any publication from the public portal for the purpose of private study or research.
- You may not further distribute the material or use it for any profit-making activity or commercial gain
- You may freely distribute the URL identifying the publication in the public portal.

If the publication is distributed under the terms of Article 25fa of the Dutch Copyright Act, indicated by the "Taverne" license above, please follow below link for the End User Agreement:

[www.tue.nl/taverne](http://www.tue.nl/taverne)

**Take down policy**

If you believe that this document breaches copyright please contact us at:

[openaccess@tue.nl](mailto:openaccess@tue.nl)

providing details and we will investigate your claim.

## Effect of Grid Disturbances on Fault-Ride-Through Behaviour of MV-connected DG-units, in especially CHP-plants

E.J. Coster<sup>1,2</sup>, J.M.A. Myrzik<sup>2</sup>, W.L. Kling<sup>2</sup>

<sup>1</sup>Stedin

<sup>2</sup>University of Technology Eindhoven  
The Netherlands

### SUMMARY

In the near future a significant amount of the consumed electrical energy will be generated by distributed generation (DG). Because of the small size these units are normally connected to the local distribution grid [1]. Connection of DG changes the operation of the distribution grid. In order to minimize the effect of DG during grid disturbances some standards oblige immediate disconnection of DG-units. With an increasing number of DG-units this strategy can lead to a disconnection of a large amount of DG-units and jeopardize the security of supply. To prevent large unbalances between generation and load because of disconnection of DG-units some grid operators have defined fault-ride-through requirements. These fault-ride-through requirements are especially applied for large wind parks which are connected to the transmission grid.

In this paper the effect of disturbances in the transmission grid on the fault-ride-through behaviour of medium voltage connected DG-units is discussed. The examined grid is an existing transmission and distribution grid. To the distribution grid a large amount of combined heat and power (CHP) plants are connected. The CHP-plants are equipped with an under-voltage protection which switches-off the CHP-plant at a voltage level (dip) of 0,8 p.u.~100 ms. In the paper it is determined what amount of CHP-plants is disconnected due to transmission grid disturbances. It can be concluded that multi-phase faults as well as single-phase-to-ground faults result in a disconnection of a significant amount of CHP-plants. Voltage dips in the transmission grid below 0,6 p.u. lead to a disconnection of all CHP-plants, between 0,6 and 0,7 p.u. lead to a partly disconnection of CHP-plants and between 0,7 and 0,8 p.u. to no disconnection at all. It is demonstrated that with a setting of 0,8 p.u.~200 ms most CHP-plants stay connected and will not lose stability.

Dynamic simulations have shown that the CHP-plants start to consume reactive power directly after fault clearing. This is due to armature reaction of the synchronous generator. The amount of consumed reactive power is related to the fault duration. The voltage recovery in medium voltage grids is delayed due to this reactive power consumption. This can lead to a disconnection of CHP-plants even when the fault is cleared within the clearing time of the under-voltage protection. The delay in voltage recovery has to be taken into account when fault-ride-through requirements for transmission grid faults are defined.

### KEYWORDS

Distributed generation, Fault-ride-through, Medium voltage grid, Stability, Distribution grid

## 1. INTRODUCTION

In the past decade new generating units, such as wind turbines, combined heat and power plants (CHP) and solar panels, has been connected to the distribution grid and has changed the traditional operation of these grids. Due to the environmental impact of conventional power plants, CO<sub>2</sub>-reduction goals and the liberalisation of the energy market it is expected that the number of small generating units will further increase in the near future.

### 1.1 Effect of DG on distribution grids

Traditionally distribution grids are passive grids which transport electric power to the connected customers. Introducing distributed generation (DG) has an impact on the operation of distribution grids. Connection of DG can lead to bi-directional power flows, change in grid losses, change in fault levels and affection of the grid protection. In [2] these issues are discussed in detail. To prevent interference with the grid protection some standards, for instance the IEEE Std. 1547, prescribe disconnection of DG during a grid disturbance. The disconnection can be initiated by different relays, such as under/over-voltage and under/over-frequency relays. Due to the growth of the number of DG-units a significant amount of electricity might be generated by distributed generation in the future. To ensure security of supply there is a need to keep such generators then connected to the grid during disturbances [3, 4, 5]. Some grid operators already have setup fault-ride-through (FRT) requirements especially for large wind parks [6].

The goal of the FRT-requirements is to prevent disconnection of an undesirable portion of power generation during an abnormal situation. For wind turbines the FRT-requirements are formulated in a voltage versus time curve where several areas are distinguished in which the wind turbines have to stay connected and give voltage and frequency support. The grid support requested depends on the depth and duration of the voltage dip.

### 1.2 Problem definition

In the Netherlands DG connected to the distribution grid mainly consist of wind parks and CHP-plants. STEDIN is a local distribution network operator (DNO) and at some locations in the STEDIN area greenhouse activities are developed. Due to the clustering of the greenhouse activities the CHP-plants are clustered as well. Because of the small size of the CHP-units, the Dutch grid-code has no special requirements for grid-support during disturbances. This means that the CHP-plants will be disconnected at a voltage level of 0,8 p.u. which holds for a certain time period by the under-voltage protection. With the increasing number of CHP-plants it can become important to keep besides the large wind parks, the CHP-plants connected to the grid as well as the large wind parks. The research-questions of this paper are:

1. How large can be the amount of DG that will be disconnected in case of a fault in the transmission or the sub-transmission grid.
2. What is a suitable setting of the under-voltage protection in order to keep the CHP-plants connected to the grid during faults in the upstream networks.

To determine the optimal settings the characteristics of the CHP-plants and the medium voltage (MV)-grid will be taken into account.

## 2. EXAMINED NETWORK

Transmission grids normally have a ring or meshed grid-structure. Faults in these grids can cause voltage dips which cover a large area. Into analyse its impacts a dip propagation study grid has to be performed. In this paper an existing transmission grid of the western part of the Netherlands is used.

### 2.1 Transmission grid

In Fig. 1 the transmission grid of the province of Zuid Holland in the Netherlands is depicted. The transmission grid consists of a 150 kV grid and is connected to the national 380 kV transmission grid at three locations. Large power plants are connected to the transmission grid. From the 150 kV nodes the sub-transmission grids are connected via three winding transformers. In each substation the neutral point of at least one transformer is solidly grounded at the HV-side. A part of the transmission grid is located in an industrial area where large chemical plants, refineries and container terminals are established. In most chemical plants and refineries CHP-plants up to a rating of 60 MVA are installed to supply the electrical and thermal energy used in the production processes.

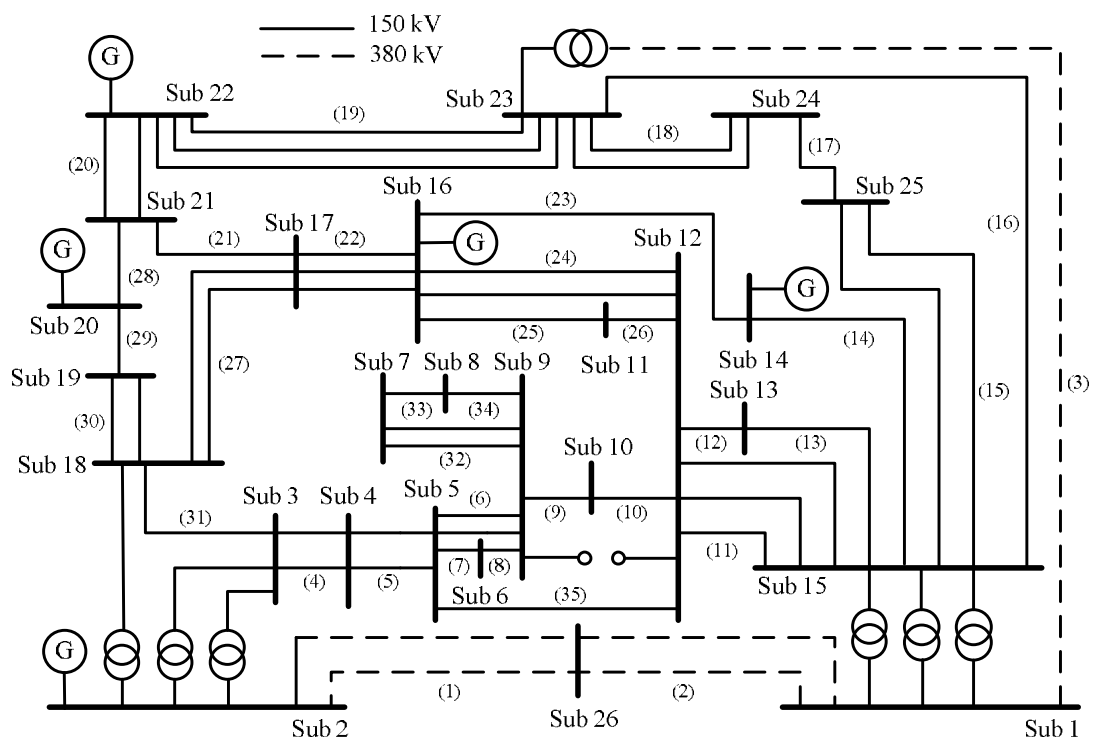

Fig. 1. Transmission grid of the province of Zuid Holland, the Netherlands

### 2.2 Distribution grid

Voltage dips which cause disconnection of CHP-plants originate from grid disturbances at different voltage levels. Therefore the sub-transmission grid and the distribution grid of the area of interest are modelled as well. In this paper an existing distribution grid structure is considered built in a horticultural area where CHP-plants are connected to. An overview of the distribution grid is depicted in Fig. 2. The considered distribution grid consists of a 10 kV MV-grid which is connected to a 25 kV sub-transmission grid. The sub-transmission grid is via 150/25 kV transformers connected to substation 'Sub 23' of the 150 kV transmission grid shown in Fig. 1. At the 25 kV side all transformers are grounded via a resistor of 10  $\Omega$ . The 10 kV distribution grid is operated with an isolated neutral point and radial feeders where the CHP-plants are connected to. The data of the load and generation connected to the 10 kV distribution grid is given in table 1.

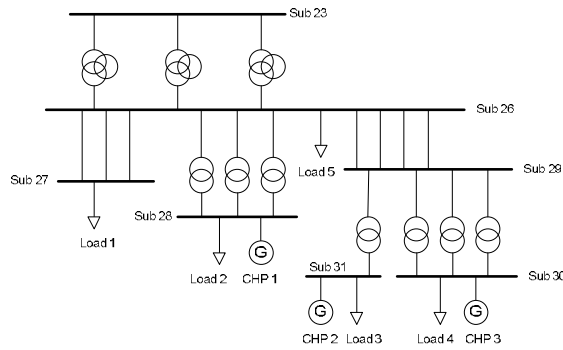

Table 1 Data of the distribution grid of figure 2

	Number of units	S [MVA]
Load 1	--	93.5
Load 2	--	26.8
Load 3	--	16
Load 4	--	38.6
Load 5	--	29.6
CHP 1	21	42.7
CHP 2	4	4.95
CHP 3	18	34.7

Fig. 2. Overview of the distribution grid in a horticultural area

### 2.3 DG penetration level

To indicate what amount of DG is connected to a certain area the concept of penetration level is introduced. In the literature various definitions of penetration level of DG-units can be found. In [7] the penetration level is defined as:

$$\%DG = \frac{P_{DG}}{P_{Load} + P_{DG}} \cdot 100[\%]$$

In [8] the definition of the penetration level is slightly different and defined as:

$$\%DG = \frac{P_{DG}}{P_{Load}} \cdot 100[\%]$$

In both definitions  $P_{DG}$  is the total installed active DG-power in a given area and  $P_{Load}$  is the total active load-power in the same area. In this paper the second definition is used and the penetration level is determined per 150 kV substation. In table 2 an overview of the DG-penetration level is given. In this paper the in [1] suggested categories of DG rating are used.

- Small DG:  $5 \text{ kW} < P_{DG} < 5 \text{ MW}$
- Medium DG:  $5 \text{ MW} < P_{DG} < 50 \text{ MW}$

The CHP-plants installed in refineries and chemical plants are of the category medium DG and will be indicated as 'Industrial CHP'. The CHP-plants installed in the greenhouses are of the category small DG and indicated as 'Horticultural CHP'.

Table 2 Overview of the penetration level per 150 kV sub-station

Substation	Load MW	%DG	DG-type	Substation	Load MW	%DG	DG-type
Sub 3	78	158,0	Industrial CHP/Wind	Sub 9	366	15,0	Industrial CHP/Wind
Sub 4	155	101,0	Industrial CHP/Wind	Sub 10	57	40,6	Industrial CHP
Sub 6	100	46,0	Horticultural CHP	Sub 17	144	34,7	Horticultural CHP
Sub 7	58	27,8	Industrial CHP	Sub 18	250	250,0	Horticultural CHP
Sub 8	80	269,0	Industrial CHP	Sub 23	204	53,3	Horticultural CHP

### 3. DIP CLASSIFICATION

A power system disturbance will often be accompanied by a voltage dip. The effect of the voltage dip experienced by the MV-connected DG-unit strongly depends on the location of the disturbance in the network and the type of disturbance. Voltage dips caused by disturbances in the transmission grid will cover a large area, while disturbances in the low-voltage network are hardly noticeable in the local MV-grid [9]. In this section a classification of voltage dips which lead to a disconnection of MV-connected DG-units will be given. The dip classification will be completed with a discussion on dip propagation of various types of voltage dips.

Voltage dips are characterized by the depth, duration and frequency of occurrence. The depth of the dip is determined by the fault location, feeder impedance and fault level. The dip duration is mainly determined by the fault-clearing time of the protection scheme. An exact definition of a dip and its characteristics can be found in [10]. Severe voltage dips are caused by balanced three-phase faults. However, most faults are unbalanced. These unbalanced faults lead to unbalanced voltage dips.

Table 3 Classification of voltage-dips [11]

Type	Voltages	Phasor
<b>A</b>	$U_a = V^*$ $U_b = -\frac{1}{2}V^* - \frac{1}{2}j \cdot V^* \sqrt{3}$ $U_c = -\frac{1}{2}V^* + \frac{1}{2}j \cdot V^* \sqrt{3}$	
<b>B</b>	$U_a = V^*$ $U_b = -\frac{1}{2}E_1 - \frac{1}{2}j \cdot E_1 \sqrt{3}$ $U_c = -\frac{1}{2}E_1 + \frac{1}{2}j \cdot E_1 \sqrt{3}$	
<b>C</b>	$U_a = E_1$ $U_b = -\frac{1}{2}E_1 - \frac{1}{2}j \cdot V^* \sqrt{3}$ $U_c = -\frac{1}{2}E_1 + \frac{1}{2}j \cdot V^* \sqrt{3}$	
<b>D</b>	$U_a = V^*$ $U_b = -\frac{1}{2}V^* - \frac{1}{2}j \cdot E_1 \sqrt{3}$ $U_c = -\frac{1}{2}V^* + \frac{1}{2}j \cdot E_1 \sqrt{3}$	
<b>E</b>	$U_a = E_1$ $U_b = -\frac{1}{2}V^* - \frac{1}{2}j \cdot V^* \sqrt{3}$ $U_c = -\frac{1}{2}V^* + \frac{1}{2}j \cdot V^* \sqrt{3}$	
<b>F</b>	$U_a = V^*$ $U_b = -\frac{1}{2}V^* - \left(\frac{1}{3}E_1 + \frac{1}{6}V^*\right)j \cdot \sqrt{3}$ $U_c = -\frac{1}{2}V^* + \left(\frac{1}{3}E_1 + \frac{1}{6}V^*\right)j \cdot \sqrt{3}$	
<b>G</b>	$U_a = \frac{2}{3}E_1 + \frac{1}{3}V^*$ $U_b = -\frac{1}{3}E_1 - \frac{1}{6}j \cdot V^* - \frac{1}{2}jV^* \cdot \sqrt{3}$ $U_c = -\frac{1}{3}E_1 - \frac{1}{6}j \cdot V^* + \frac{1}{2}jV^* \cdot \sqrt{3}$	

For the classification of the voltage dips in the literature several approaches are used. In [10] a classification method is presented which groups the voltage dips in six categories based on the depth and duration of the dip. This classification method is especially useful for power quality purposes in medium and low voltage grids. The classification method used in this paper distinguishes between seven types of three-phase unbalanced voltage dips [11]. In table 3 an overview including an expression for the complex voltages of these seven types are given. In the expressions the pre-fault voltage is indicated with  $E_1$  and the voltage of the faulted phase or between the faulted phases is indicated by  $V^*$ .

### 3.1 Dip propagation

The small CHP-plants considered in this paper are equipped with an under-voltage protection which disconnects the plant when there is a dip of a certain value and duration in the line-voltage. The goal of the classification is to find the fault-types which lead to a disconnection of the CHP-plants. In [9, 12] it is demonstrated that the transformer connection has an effect on the propagation of dips. To determine what disturbance in the transmission grid lead to a dip in the line-voltage in the MV-grid all transformers from transmission grid to local distribution grid have to be taken into account. As shown in figure 3 the examined distribution grid is connected via a sub-transmission grid to the transmission grid. This holds for all distribution grids in the STEDIN-area. The sub-transmission grids are operated at an

intermediate voltage level (50&25 kV). Via two winding transformers local distribution grids operated at medium voltage (10&20 kV) are connected.

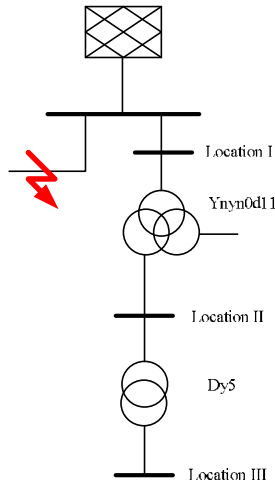

Fig. 3. Connection of a distribution grid of a greenhouse-area to the transmission grid

Table 4 Dip-propagation for phase-voltages

Fault-type (Phase voltages)	Measurement location		
	I	II	III
Three-phase	A	A	A
Two phase-to-ground	E	G	F
Two -phase	C	C	D
Single-phase-to-ground	B	D	C

Table 5 Dip-propagation for line-voltages

Fault-type (Line voltages)	Measurement location		
	I	II	III
Three-phase	A	A	A
Two phase-to-ground	F	F	G
Two -phase	D	D	C
Single-phase-to-ground	C	C	D

For the network of figure 3 at the indicated location various fault-types are simulated and the dip-type at different voltage levels according to table 3 is determined. The simulated fault-types are:

1. Three-phase fault (dip-type A)
2. Double-phase-to-ground fault (dip-type E)
3. Double-phase fault (dip-type C)
4. Single-phase-to-ground fault (dip-type B)

The results for the dips in the phase-voltages are shown in table 4 and for the line-voltages in table 5. Comparing the results of table 4 and 5 it can be seen that a certain dip-type in the phase-voltage leads to another dip-type in the line-voltage. Furthermore it can be concluded that three phase voltage dips propagate unaltered through the different transformer winding connections. Unbalanced multi-phase faults cause dips in the line-voltage which also propagates to the local distribution grid. The dip-type of the phase-voltages caused by a single-phase-to-ground fault in the transmission grid is converted to type D due to the tertiary delta-winding of the transformer (blocking of the zero-sequence component [9]) and converted to type C due to the Dy-winding configuration. For a single-phase-to-ground fault in the transmission system the dip-type of the line-voltages is C and due to the transformer winding connections converted to D (see table 5). Hence in general for the configuration shown in figure 3 it can be concluded that all examined dip-types lead to a dip in the line-voltage in the local distribution grid.

### 3.2 Simulation results

The amount of CHP-plants which will be disconnected during a grid disturbance in the transmission system is assessed with a short-circuit current analysis of the network model discussed in section 2. This analysis starts with the determination of areas in the transmission grid where disturbances can lead to a disconnection of the CHP-plants of 'Sub 23'. Therefore for all lines and busses in the transmission system, symmetrical as well as asymmetrical short circuits are simulated. For the lines the location of the short-circuit is set to 50% of the total line-length. During the simulation busbar-voltages of all substations are stored. To present the results the fault-cases are grouped in three categories:

1.  $0 < U_{\text{Sub}23} < 0.6$  p.u.
2.  $0.6 < U_{\text{Sub}23} < 0.7$  p.u.
3.  $0.7 < U_{\text{Sub}23} < 0,8$  p.u.

Each category contains the fault-cases for which the busbar-voltages of 'Sub 23' drop between the limits of the appropriate category. In figure 4 and 5 the defined categories are indicated as areas wherein disturbances lead to a voltage drop of 'Sub 23' as given in the category. Figure 4 holds for

three-phase, double-phase and double-phase-to-ground faults while figure 5 holds for single-phase-to-ground faults.

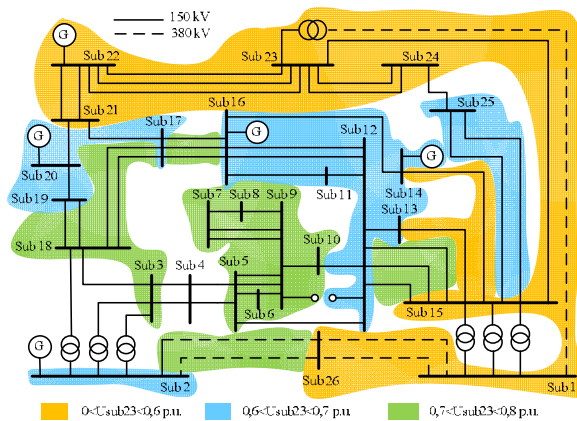

Fig. 4. Overview of areas wherein multi-phase faults lead to a certain voltage dip at 'Sub 23'

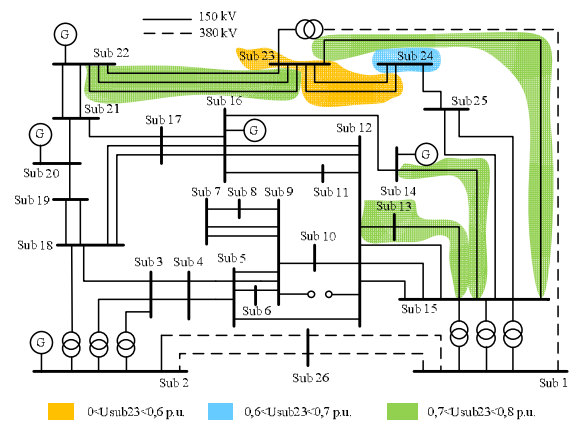

Fig. 5. Overview of areas wherein single-phase-to-ground faults lead to a certain voltage dip at 'Sub 23'

Comparing figure 4 and 5 it can be seen that there is only a limited area where a single-phase-to-ground fault leads to a significant voltage drop of 'Sub 23'. The effect of a single-phase-to-ground fault is determined by the neutral grounding and values of the zero-sequence impedance. The effect of the zero-sequence impedance results in a common-mode component in the phase-voltages hence a single-phase-to-ground fault has only a small effect on the line-voltages [9].

For the fault-cases of the defined categories dynamic simulations are carried out. In the model all CHP-plants are equipped with an under-voltage protection which is set at a pick-up voltage of 0,8 p.u. and a clearing time of 100 ms. The simulated fault-types are three-phase, double-phase-to-ground and single-phase-to-ground faults in the middle of the lines and have a duration of 100 ms. In figure 6 per fault-case the percentage disconnected CHP-plants is given.

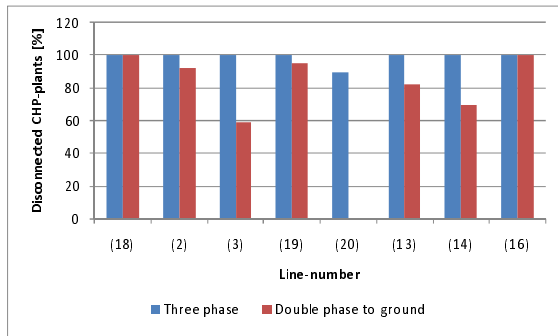

Fig. 6a. Results  $0 < U_{sub23} < 0,6$  p.u. area

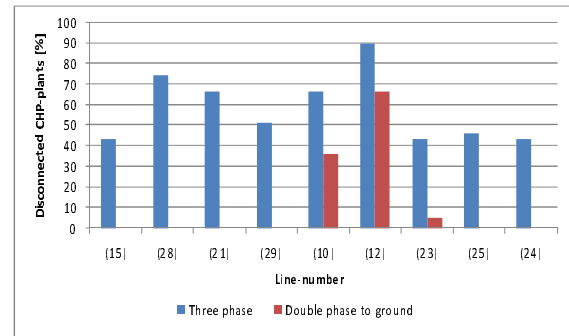

Fig. 6b. Results  $0,6 < U_{sub23} < 0,7$  p.u. area

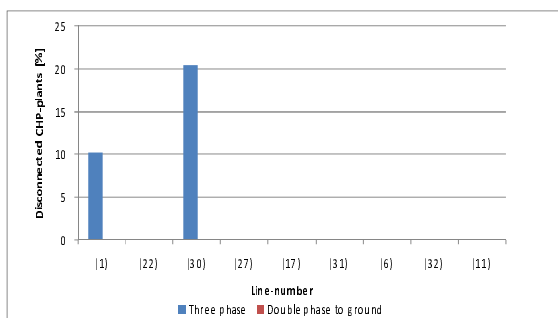

Fig. 6c. Results  $0,7 < U_{sub23} < 0,8$  p.u. area

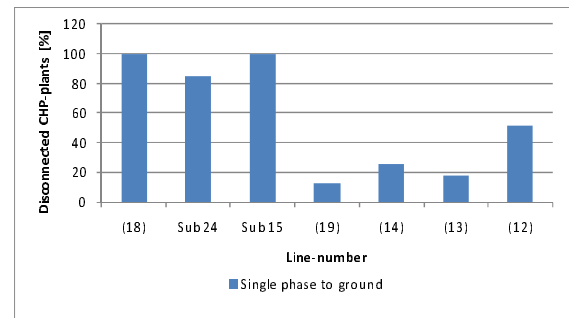

Fig. 6d. Results  $0 < U_{sub23} < 0,8$  p.u. area



As described in [9] due to the contribution of the CHP-plants to the fault the CHP-plants tends to keep up the voltage in the distribution grid. This especially holds for MV-feeders where more than one CHP-plant is connected. In figure 6a it can be concluded that for three-phase faults leading to a voltage dip below 0,6 p.u. in the transmission grid all CHP-plants disconnect. For all fault cases the accompanying voltage dip is sufficient to trigger the under-voltage protection. For a double-phase-to-ground fault the voltage dip in the distribution grid is less severe as in the case of the three-phase fault hence less CHP-plants are switched-off. In figure 6b and 6c it can be seen that the number of disconnected CHP-plants reduces. This is because of the less deep voltage dips and the effect of the CHP-plants on their local busbar-voltage. In figure 6b a double-phase-to-ground fault leads to a disconnection of CHP-plants for only a limited number of cases. Shallow voltage dips between 0,7 and 0,8 p.u. caused by a double-phase-to-ground fault do not lead to a disconnection of CHP-plants at all.

In figure 6d the results for a single-phase-to-ground fault are given. There are only a limited number of fault cases which lead to complete disconnection of all CHP-plants. Grid disturbances which lead to a voltage dip between 0,7 and 0,8 p.u. results in a partial disconnection of CHP-plants. In comparison with the multi-phase faults the number of disconnection in case of single-phase-to-ground faults is restricted.

#### 4. FAULT-RIDE-THROUGH OF CHP-PLANTS

In the previous section it is demonstrated that disturbances in the transmission grid can lead to switch-off of a large number of CHP-plants. Because the disturbance is located in the transmission grid, there is no obvious reason to disconnect the CHP-plants. Disconnection can be prevented easily by changing the settings of the under-voltage protection. However, changing the settings of the under-voltage protection means that the CHP-plants stay longer connected to the grid during a disturbance hence the stability limit of the CHP-plants should not be exceeded. A measure for stability of synchronous machines is the critical clearing time (CCT). The critical clearing time is the ability of a synchronous machine to withstand a voltage dip with a certain depth and duration and stay in stable operation. For all type of CHP-plants connected to the test system the CCT is determined. In table 6 the simulation figures of the CHP-plants are given.

Table 6 Simulation figures of CHP-plants

S [MVA]	P [MW]	H [s]	p.f.
2.475	1.98	0.817	1
3.767	3.01	0.869	1
4.156	3.32	0.862	1

In normal operation the CHP-plants are operated with unity power-factor. In [13] it is described in detail how the CCT of the CHP-plants is obtained. In fig. 7 the CCT-curves are depicted. The CHP-plant with the smallest inertia gives the most critical CCT-curve. To guarantee stable operation of this CHP-plant during fault-ride-through, this curve is taken as a reference to define the new settings of the under-voltage protection.

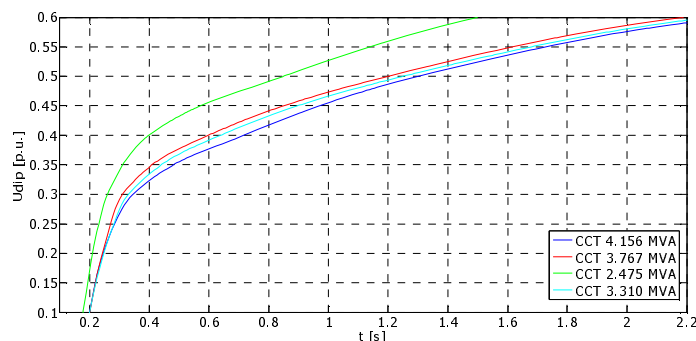

Fig. 7. CCT-curves for the CHP-plants connected to the distribution grid

In the examined transmission grid most lines are protected by distance protection and a few lines by differential protection. For zone 1 fault-clearing of the distance protection and fault-clearing of the differential protection the average fault-clearing time is 100 ms. According to figure 7 a proposed setting of 0,8 p.u.~200 ms does not lead to instability of the CHP plants. Simulations have shown that with the new settings for all fault-cases studied in figure 6 the CHP-plants stay connected.

#### 4.1 Grid interaction of CHP-plants

Keeping the CHP-plants connected to the grid during disturbances in the transmission grid introduces a dynamic interaction between the CHP-plants and the grid. In the simulations it is found that after fault-clearing the CHP-plants start to consume reactive power for a short period of time.

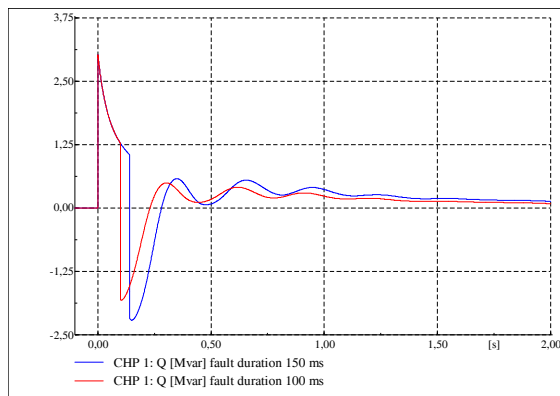

Fig. 8a. Reactive power consumption due to a three-phase fault in the transmission grid

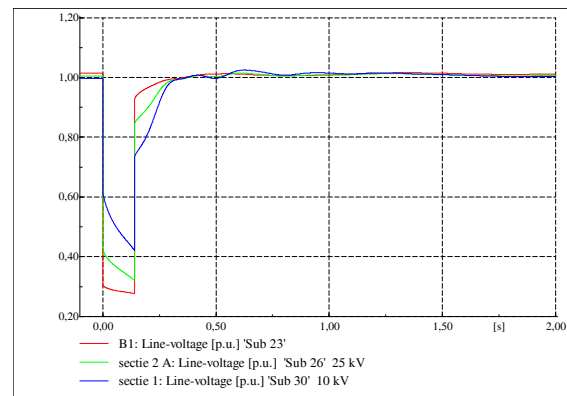

Fig. 8b. Voltage recovery due to a three-phase fault in the transmission grid

In figure 8a the reactive-power exchange of a CHP-plant during and after a three-phase fault in the transmission grid are depicted. This exchange is shown for a fault-duration of 100 ms and 150 ms. During the disturbance the CHP-plant contributes to the fault. After fault-clearing there is a short moment of time (130 ms) where the CHP-plant consumes reactive power. When the fault duration increases, the consumed reactive power by the CHP-plant increases as well. The reactive-power consumption is due the armature reaction of the synchronous generator. During the disturbance there is interference between armature flux and rotor flux and the net flux in the generator reduces. After fault-clearing the rotor and armature flux has to be rebuilt to the stationary value which leads to consumption of reactive power for a short period of time. Details on armature reaction can be found in [14].

Because of the large number of CHP-plants connected to the local MV-grid a considerable amount of reactive power is consumed after fault-clearing. In figure 8b the voltages of 'Sub 23', 'Sub 26' and 'Sub 30' (see fig. 2) are given. It can be seen that there is a delayed voltage restoration of 'Sub 30' caused by reactive power consumption of the CHP-plants. Because of the delayed voltage restoration the dip-duration increases and the new settings of the under-voltage protection can be exceeded. This can result in a disconnection of CHP-plants even when the fault is cleared within the clearing time of the under-voltage protection. This effect does not lead to disconnection of CHP-plants when the fault is cleared in 100 ms.

#### 4.2 Fault-ride-through of CHP-plants for distribution grid faults

The accompanying voltage dip of disturbances in the transmission grid can cover a large area by which DG-units, connected to distinct distribution grids, are influenced. However, disturbances in the sub-transmission grid affect the distribution grids connected to this grid as well. In this paper the examined sub-transmission grid covers a complete greenhouse area. Disturbances in the sub-transmission grid cause deeper voltage dips at the MV-busbar and terminals of the CHP-plant hence with a pick-up voltage of 0,8 p.u. and a clearing time of 200 ms this lead to a disconnection of all CHP-plants. To keep the CHP-plants connected to the grid also during faults in the sub-transmission

grid, the grid protection has to clear the fault before the under-voltage protection switches-off the CHP-plants. The fault-clearing time of the protection of the sub-transmission grid is set to 300 ms hence the clearing time of the under-voltage protection has to be larger. The combination of deeper voltage dips due to the sub-transmission grid faults and a longer clearing time of the under-voltage protection can result in an exceeding of the CCT of the CHP-plants as shown in figure 7. To guarantee stability and prevent disconnection of CHP-plants because of disturbances in the sub-transmission grid the number of pick-up levels of the under-voltage protection has to be extended. The settings have to be such that the CCT of the CHP-plants is not exceeded. In [15] this approach is discussed in detail and it is demonstrated that it is possible to keep the CHP-plants in stable operation during sub-transmission grid faults.

## 5. CONCLUSIONS

In this paper the disconnection and fault-ride-through of MV-connected CHP-plants is studied. For this purpose an existing transmission grid is used to which an existing sub-transmission and distribution grid in a greenhouse-area is connected. It is demonstrated that multi-phase faults in can lead to disconnection of a significant number of CHP-plants in a wide area. Because the sub-transmission and distribution grid of other greenhouse-areas are connected to different substations of the transmission grid as well, a single disturbance can result in a disconnection of a large amount of CHP-plants.

The voltage dips as a result of the transmission grid disturbances are grouped in three categories. Voltage dips in the category 0-0,6 p.u. lead in most cases to a disconnection of all CHP-plants. For the voltage dips in the category 0,6-0,7 p.u. only a small amount of CHP-plants are disconnected while for the category 0,7-0,8 p.u. hardly a CHP-plant is disconnected. During the grid disturbance the CHP-plants contribute to the fault and keep up the voltage of the distribution grid. Due to this voltage support the number of disconnected CHP-plants reduces.

The CHP-plants are equipped with an under-voltage protection and during grid disturbances this protection switches-off the CHP-plants. Because for small DG-units there are no fault-ride-through requirements in the grid-code manufactures choose a safe setting of 0,8 p.u.~100 ms. In transmission grids the average fault-clearing time is 100 ms and it is demonstrated that for all transmission grid faults disconnection of CHP-plants can be prevented with a setting of the under-voltage protection of 0,8 p.u.~200 ms. It is recommended to introduce this in the grid-code requirements for the under-voltage protection of small DG-units. This is within the stability limit of a CHP-plant.

Keeping CHP-plants connected affects the voltage recovery in MV-grids. Due to armature reaction after fault-clearing the CHP-plants start to consume reactive power. The reactive power consumption delays the voltage recovery in the MV-grid. The amount of consumed reactive power is related to the fault duration. The delayed voltage-recovery has to be taken into account for a definition of fault-ride through requirements for sub-transmission grid disturbances.

## BIBLIOGRAPHY

- [1] Ackermann, T., Anderson, G. Söder, L. 'Distributed Generation: a definition' Electric Power Systems Research, Elsevier Science 2001 pp 196-204
- [2] Ackermann T., Knyazin, V., 'Interaction between Distributed Generation and the Distribution Network: Operation Aspects'
- [3] Erlich, I., Bachmann, U., 'Grid Code requirement Concerning Connection and Operation of Wind Turbines in Germany' PES General Meeting, San Francisco CA, USA, 2005
- [4] Johnson, A., Tleis, N., 'The development of grid code requirements for new and renewable forms of generation in Great Britain' Wind Engineering, vol. 29 no. 3, pp 201-215, 2005
- [5] Buchholz, B.M., Winter W., Styczynski, Z.A., 'Dynamic simulations of renewable energy sources and requirements on fault ride through behavior' PES General Meeting Montreal, Canada ,18-22 June, 2006
- [6] E.on Netz, 'Grid code for high and extra high voltage', 1<sup>st</sup> April 2006
- [7] Donnelly, M.K., Dagle, J.E., Trudnowski, D.J., 'Impact of Distributed Utility on Transmission System Stability', IEEE Transactions on Power Systems, Vol. 11, No 2, May 1996
- [8] Knyazkins, V., 'Stability of Power Systems with large amounts of Distributed Generation', Ph.D thesis, KTH Stockholm, Sweden, 2004
- [9] Bollen, M.H.J. 'Understanding Power Quality Problems' IEEE Press, New York, 2000
- [10] Cobben, J.F.G. 'Power Quality, Implications at the Point of Connection', Ph.D thesis, TU Eindhoven, the Netherlands, 2007
- [11] Bollen, M.H.J., Zhang, L.D., 'Different methods for classification of three-phase unbalanced voltage dips due to faults', Electric Power Systems Research, Vol. 66, Issue 1, July 2003
- [12] Aung, M.T., Milanović, J.V., 'The Influence of Transformer Winding Connection on the Propagation of Voltage Sags', IEEE Transactions on Power Delivery, Vol. 21, No 1 January 2006
- [13] E.J. Coster, A. Ishchenko, J.M.A. Myrzik and W.L. Kling, "Comparison of Practical Fault Ride Through Capabilities for MV-connected DG-units", Presented at 16<sup>th</sup> Power System Computation Conf., Glasgow, Scotland, 2008
- [14] Machowski, J. Bialec, J.W., Bumby, J.R., 'Power System Dynamics and Stability', 1997, Wiley and Sons, New York
- [15] Coster, E.J., Myrzik, J.M.A., Kling, W.L., 'Grid Interaction of MV-connected CHP-plants during Disturbances', PES General Meeting, Calgary AB, Canada, 2009