

Natural circulating current control of a cycloconverter

Citation for published version (APA):

Bosga, S. G., Duarte, J. L., Offringa, L. J. J., & Vandenput, A. J. A. (1993). Natural circulating current control of a cycloconverter. In *Proceedings Industry Applications Society Annual Meeting, Toronto, Ont. 2-8 Oct 1993* (pp. 1160-1165). Institute of Electrical and Electronics Engineers. <https://doi.org/10.1109/IAS.1993.299043>

DOI:

[10.1109/IAS.1993.299043](https://doi.org/10.1109/IAS.1993.299043)

Document status and date:

Published: 01/01/1993

Document Version:

Publisher's PDF, also known as Version of Record (includes final page, issue and volume numbers)

Please check the document version of this publication:

- A submitted manuscript is the version of the article upon submission and before peer-review. There can be important differences between the submitted version and the official published version of record. People interested in the research are advised to contact the author for the final version of the publication, or visit the DOI to the publisher's website.
- The final author version and the galley proof are versions of the publication after peer review.
- The final published version features the final layout of the paper including the volume, issue and page numbers.

[Link to publication](#)

General rights

Copyright and moral rights for the publications made accessible in the public portal are retained by the authors and/or other copyright owners and it is a condition of accessing publications that users recognise and abide by the legal requirements associated with these rights.

- Users may download and print one copy of any publication from the public portal for the purpose of private study or research.
- You may not further distribute the material or use it for any profit-making activity or commercial gain
- You may freely distribute the URL identifying the publication in the public portal.

If the publication is distributed under the terms of Article 25fa of the Dutch Copyright Act, indicated by the "Taverne" license above, please follow below link for the End User Agreement:

www.tue.nl/taverne

Take down policy

If you believe that this document breaches copyright please contact us at:

openaccess@tue.nl

providing details and we will investigate your claim.

Natural Circulating Current Control of a Cycloconverter

S.G. Bosga, J.L. Duarte, L.J. Offringa, A.J. Vandenput

Eindhoven University of Technology
PO Box 513, 5600 MB Eindhoven, The Netherlands

Abstract - In order to perform experimental verifications of theoretical analyses and simulations related to field oriented controlled ac drives, especially at low frequencies, a 20 kVA power converter was needed. This converter should act as a voltage amplifier, allowing the load current to change direction without discontinuities. For this purpose a 6-pulse cycloconverter with circulating current was chosen.

A control method is needed to avoid that the circulating current becomes zero. Two methods from the literature were theoretically compared: a first one, in which the circulating current is controlled to a constant value, and a second one, which makes the input reactive power constant.

In this paper a new control strategy is introduced, which is based on the shape of the natural (uncontrolled) circulating current. With simulations it is shown that using this method, with a relatively simple control circuitry, the circulating current can be controlled in such a way that it never becomes zero. As a result the load current is free to change direction without becoming discontinuous and without a dead zone, and the output voltage can be controlled independently of the load current. Practical experiments confirmed the theory and the simulations.

I. INTRODUCTION

Cycloconverters are frequently used in high power AC drive systems to provide a voltage with variable amplitude and frequency. While studying the characteristics of different field oriented control systems, especially at low frequencies, a converter was needed which acts as a voltage amplifier, providing the requested output voltage independent of the load current.

A cycloconverter without circulating current would require a special voltage control at low load currents, because of discontinuous conduction of its thyristors. Also a dead time has to be introduced whenever the load current crosses zero [1].

When using a cycloconverter with circulating current, the output voltage can be controlled merely by imposing the thyristor fire angle, and without using a voltage control loop. However, the circulating current has to be controlled in such a way that it remains greater than zero, in order to avoid discontinuous conduction.

In this paper, different circulating current control strategies [2,3] are compared, and a new method is introduced. Experimental results were obtained using a 20 kVA laboratory drive system.

0-7803-1462-x/93\$03.00 ©1993IEEE

II. BEHAVIOR OF THE CIRCULATING CURRENT

In order to derive a control strategy for the circulating current first the behaviour of this current in the power circuit is studied, and the current is calculated for the case when no control is applied to it. This uncontrolled circulating current is called the natural circulating current.

A. Circuit and Definitions

The power circuit for each phase of the converter consists of two 6-pulse bridges, which are both connected to the same transformer. These bridges are connected to each other with the so called circulating current reactors, while the load is connected between the middle taps of these reactors, as shown in Fig. 1.

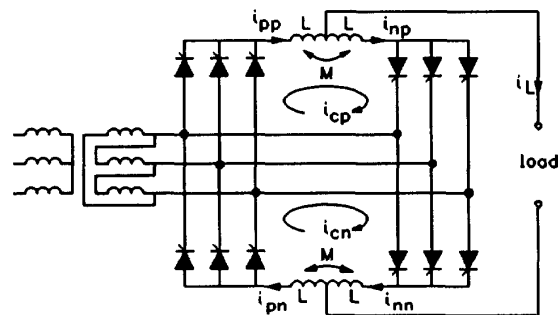

Fig. 1. Schematic diagram of the power circuit.

The left-side 6-pulse bridge, called the p-converter, carries besides the circulating current also the load current i_L whenever it is positive. Its average output voltage is given by

$$\langle v_p \rangle = \frac{6\sqrt{3}}{2\pi} A \cos \alpha_p, \quad (1)$$

where A is the amplitude of the sinusoidal line-to-neutral input voltage, and α_p the firing angle ($\langle \rangle$ denotes a value averaged over the ripple). The other bridge, the n-converter, also carries the circulating current, together with the load current i_L whenever it is negative. Its output voltage (v_n) is controlled by the firing angle α_n .

As both bridges are connected to the same transformer, two different circulating currents have to be distinguished: i_{cp} and i_{cn} . Here i_{cp} is the component of the current flowing in the upper part of the two bridges which does not

contribute to the load current. Thus

$$\begin{aligned} i_{cp} &= i_{pp} - i_L \quad (i_L > 0) \\ i_{cp} &= i_{np} - (-i_L) \quad (i_L < 0). \end{aligned} \quad (2)$$

As can be seen from Fig. 1

$$i_L = i_{pp} - i_{np}, \quad (3)$$

from which can be deduced that

$$i_{cp} = \frac{1}{2}(i_{pp} + i_{np} - |i_L|). \quad (4)$$

For i_{cn} it can be deduced similarly that

$$i_{cn} = \frac{1}{2}(i_{pn} + i_{nn} - |i_L|). \quad (5)$$

If the circuit is symmetric the average values of i_{cp} and i_{cn} will be equal. Instead of controlling them separately, we can control their sum i_{cT} , which is a function of the load current and two converter currents, defined by

$$\begin{aligned} i_{pT} &= \frac{1}{2}(i_{pp} + i_{pn}) \\ i_{nT} &= \frac{1}{2}(i_{np} + i_{nn}) \\ i_{cT} &= \frac{1}{2}(i_{cp} + i_{cn}), \end{aligned} \quad (6)$$

from which can be seen that

$$i_{cT} = \frac{1}{2}(i_{pT} + i_{nT} - |i_L|). \quad (7)$$

In case only this current is controlled, care must be taken to control the firing angles in such a way that $\langle i_{cp} \rangle$ remains equal to $\langle i_{cn} \rangle$. As i_{cp} can be seen to result from the voltage difference between two 3-pulse bridges, it will contain a component of three times the line frequency ($3 \cdot 50 = 150$ Hz). If this component would get into the reference voltages, through the circulating current controller, the upper three thyristors would be fired at another instant than the lower three, leading to an asymmetry which results in a difference between $\langle i_{cp} \rangle$ and $\langle i_{cn} \rangle$.

Fortunately, i_{cT} does not contain this component, as it results from the voltage difference between the two 6-pulse bridges. Therefore control can be based on this current without causing an asymmetry. To obtain i_{cT} (according to (7)), only two out of i_{pT} , i_{nT} and i_L have to be measured, as the third current can be calculated using

$$i_L = i_{pT} - i_{nT}. \quad (8)$$

The addition of i_{pp} and i_{pn} to obtain i_{pT} can usually be performed by one current sensor. So finally only two current sensors are needed, e.g. one for i_L and one for $i_{pp} + i_{pn}$.

B. Circulating Current Control

Fig. 2 shows an equivalent circuit which can be used to find the relation between the converter voltages, the output

voltage and the circulating current. It is valid only if the four converter currents are greater than zero. After neglecting the ripple and using Laplace transform, the following equations are obtained:

$$\begin{aligned} V_p &= V_L + (R + sL)(I_{pp} + I_{pn}) + sM(I_{nn} + I_{np}) \\ V_n &= V_L - (R + sL)(I_{np} + I_{nn}) - sM(I_{pp} + I_{pn}). \end{aligned} \quad (9)$$

It should be noted that the upper and lower reactors are not coupled, since coupling in one direction would decrease the inductance in the i_{cT} circuit, while coupling in the other direction would decrease the inductance for $(i_{cp} - i_{cn})$, and therefore increase the difference between i_{cp} and i_{cn} .

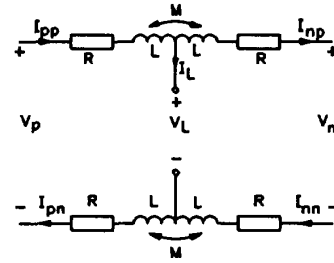

Fig. 2. Equivalent circuit used to calculate the circulating current.

Using the above equations the converter output voltage is found to be

$$V_L = \frac{1}{2}(V_p + V_n) - (R + s(L - M))I_L, \quad (10)$$

while the circulating current can be written as a function of the voltage difference $V_p - V_n$ and the load current I_L , as in (11).

$$I_{cT} = \frac{1}{4} \frac{V_p - V_n}{R + s(L + M)} - \frac{1}{2} |I_L|. \quad (11)$$

From this equation it can be seen that I_{cT} can be controlled by imposing $V_p - V_n$, while according to (10) this voltage difference does not have any influence on the output voltage. However, the load current acts as a disturbance, and control speed is limited both by the inductance $L + M$ and by the delay between the reference and the output voltage of a bridge.

C. Natural Circulating Current

If no circulating current control is applied V_p and V_n will be equal, so the circulating current will depend only on the absolute value of the load current. Initially the circulating current will be zero, and as soon as a positive load current starts to flow this current will be carried by the p-converter. Only when the load current will start to decrease, a circulating current will start flowing, in such a way that the energy stored in the reactors remains constant, as the average voltage over the reactors, $\langle v_p \rangle - \langle v_n \rangle$, is zero. The amplitude of the different currents is shown in Fig. 3.

This uncontrolled, so called natural circulating current

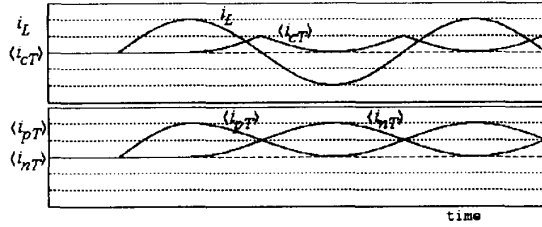

Fig. 3. The natural circulating current, neglecting the ripple.

can now be described by

$$i_{cT} = \frac{|\hat{i}_L| - |i_L|}{2}, \quad (12)$$

where the resistance of the reactors is neglected. Due to this resistance i_{cT} will slowly vanish if the load current remains zero for a certain time. Fig. 3 also shows that (i_{cT}) will become zero two times in every period of the load current. Control of i_{cT} is needed to avoid this discontinuous conduction, since it leads to a disturbance in the output voltage and in the output impedance.

III. CIRCULATING CURRENT CONTROL STRATEGIES

The different control methods use the same basic control diagram shown in Fig. 4. Here the converter is supposed to be ideal except for a delay τ between the reference and the output voltage. The reference current can either be taken constant, which is the most simple case, or dependent on other currents or voltages. By using the compensation input, a forward compensation can be realized to reduce or eliminate the influence of the load current on I_{cT} , which would considerably facilitate the work of the controller G .

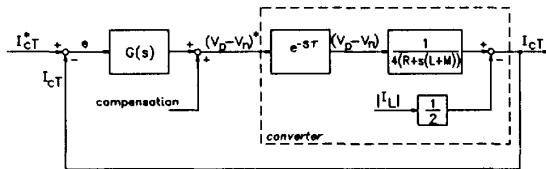

Fig. 4. Basic circulating current controller diagram.

A. Simple Control

From Fig. 4 we can deduce the following equation for I_{cT} :

$$I_{cT} = -\frac{1}{2} |I_L| + \frac{e^{-s\tau} G(s)}{4(R+s(L+M))} (I_{cT}^* - I_{cT}) + \frac{e^{-s\tau}}{4(R+s(L+M))} \cdot \text{Compens.} \quad (13)$$

This equation shows that while I_L acts directly on the circulating current, the influence of the controller will be delayed, which will be a problem when the load current increases rapidly.

In order to eliminate the influence of I_L , the forward compensation should be realized as

$$\text{Compens.} = 2(R+s(L+M)) |I_L|, \quad (14)$$

where the converter delay is neglected. Thus a differentiation of the load current is needed, which can be realized easily when a ripple-free load current reference is present. The real current however will contain a (high) ripple component caused by the converter switching, which will appear in the converter reference voltage after this differentiation. It is then responsible for a difference between the average reference voltage and the reference voltage at the moments of switching, causing a difference between the average reference and output voltages. This effect is shown in Fig. 5 for the reference and output voltage of one bridge. To avoid it, very effective filtering of the reference voltage is needed. This filtering however considerably deteriorates the functioning of the compensation.

Hence it will be very difficult for this simple control scheme to maintain the circulating current equal to a constant reference in case fast variations of the load current occur.

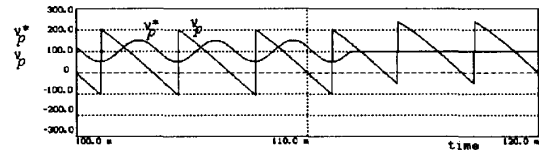

Fig. 5. The effect of a 300 Hz component in a reference voltage.

B. Reactive Power Control

The amount of reactive power consumed by the converter is a function of the load current, the circulating current and the sine of the firing angle:

$$Q \propto (2I_{cT} + |I_L|) \sin \alpha_p. \quad (15)$$

This relationship makes it possible to control the circulating current in such a way that the reactive input power remains constant, and therefore can be compensated by means of capacitors [3]. In case this compensation is done for each phase of the load separately, which allows to put the capacitors on the converter side of the transformers, a very high peak value of the circulating current is needed. If compensation is done simultaneously for the three phases of a symmetrical load, by placing capacitors at the line side of the transformers, a lower circulating current can be used.

However, keeping the reactive power consumption constant, means that it has to be constantly equal to at least the peak reactive power consumption with a circulating current equal to zero. Thus even at no-load condition a high current will flow in the power circuit, causing losses in the thyristors, the reactors and the transformers.

Another disadvantage of this method is that rather complicated calculations are needed to obtain the circulating current reference, including several multiplications, divisions and the sine of firing angles. Furthermore reactive power compensation was not required in our laboratory setup, so no simulations were performed with this method.

C. Natural Circulating Current Control

The main task of the circulating current control is to maintain the circulating current greater than zero under all possible load conditions. To obtain this, i_{cT} should be forced to be equal to a reference value which is greater than zero. This reference value, however, can not be chosen arbitrarily, as the converter delay and the load current do not allow to control i_{cT} fast enough in case of high load current variations. If the circulating current reference would be chosen to be equal to the natural circulating current, as given by (12), the circulating current would of course follow this reference, even without control. To avoid that i_{cT} becomes zero twice a period, a constant term is added. The reference then becomes:

$$i_{cT}^* = I_{cT,0}^* + \frac{|\hat{i}_L| - |i_L|}{2} \quad (16)$$

In order to obtain a circulating current equal to this reference, in stationary conditions only a constant voltage difference $v_p - v_n$ is required. By transforming (11) to the time domain and by taking $i_{cT} = i_{cT}^*$ one gets:

$$\begin{aligned} v_p - v_n &= 4(R + (L + M) \frac{d}{dt}) (I_{cT,0}^* + \frac{1}{2} |\hat{i}_L|) \\ &= 4R (I_{cT,0}^* + \frac{1}{2} |\hat{i}_L|). \end{aligned} \quad (17)$$

In dynamic situations where i_L increases to a value beyond its previous maximum, $|\hat{i}_L|$ is no longer a constant, and a higher value of $v_p - v_n$ is required.

IV. SIMULATIONS

In order to compare the cycloconverter characteristics for different circulating current control methods, simulations were performed. In these simulations the coupling between the two halves of the circulating current reactors is supposed to be ideal ($M=L$), and their resistance negligibly small. Their value is chosen in such a way that the maximum ripple in the circulating current, which occurs for $\alpha_p = 60^\circ$, is small compared to the load current's amplitude. In the simulations $L=10$ mH, although also $L=5$ mH gave satisfactory results. The load was a sinusoidal voltage source, in series with an inductance and a resistance, leading to an almost sinusoidal load current with only a small ripple. The line voltage is 380 V and because of the star-triangle transformer we obtain

$A = 220\sqrt{2}/\sqrt{3}$ in (1), resulting in a theoretically maximum output voltage of 297 V.

A. Uncontrolled Circulating Current

Fig. 6 shows the behaviour of the cycloconverter in case no circulating current control is applied. The reference voltage is sinusoidal, with a frequency of 25 Hz. The output voltage looks like the output of a PWM converter, except that the blocks are rounded off instead of flat. For higher output voltages, another higher "level" will occur, as can be seen in later simulations.

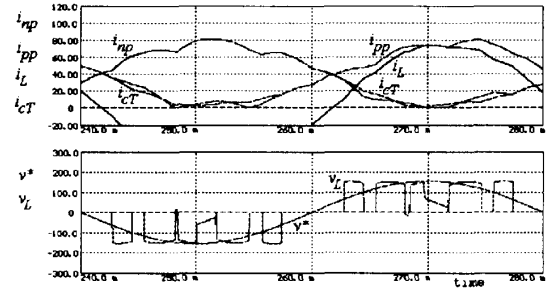

Fig. 6. Uncontrolled circulating current.

Whenever the load current reaches its maximum the circulating current, which flows in the bridge which does not carry the load current, becomes zero. It can be seen that this leads to a very strong deterioration of the output voltage. However, when the load current reaches zero, the circulating current reaches its maximum, and the load current can cross zero without any problem.

B. Simple Control

In this case a simple proportional controller as in Fig. 4 with a gain of $K=20$ is used to control the circulating current to a constant reference $I_{cT}^*=40$ A. The output of this controller is filtered with a second order filter with a critical frequency of 150 Hz, in order to filter away the 300 Hz component present in I_{cT} without causing a strong delay at frequencies up to 25 Hz. Furthermore $(v_p - v_n)^*$ is limited between -200 and 200 V in order to avoid action of the α_p and α_n limiters. The result is shown in Fig. 7.

It is clear that the functioning of this control is not very effective: when the load current is zero, the circulating current is much higher than the reference, and when $|i_L|$ reaches its maximum, it is much lower. A very high reference value was needed to avoid that i_{cT} becomes zero. No voltage deformation occurs due to the discontinuous conduction of one of the bridges. Hence, as long as the filtering of the controller output is sufficient to prevent the 300 Hz current ripple from entering in the reference voltages, this method might be used.

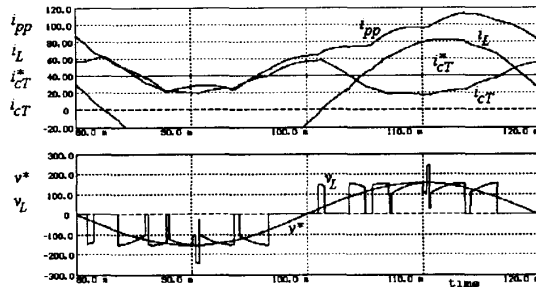

Fig. 7. Simple control.

In Fig. 8 forward compensation is added to the controller. The circulating current now remains closer to the reference, also because filtering was performed with only a first order filter at 150 Hz. The output voltage however differs more from its reference. Especially when the ripple in the load current would be higher than in this simulation, more filtering would be required.

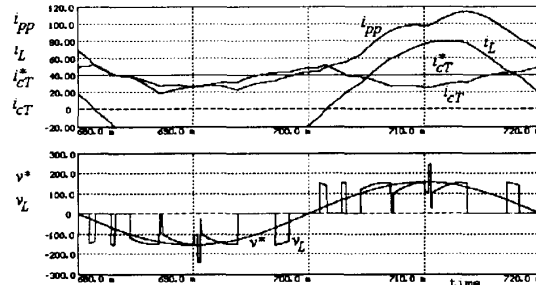

Fig. 8. Simple control with compensation.

C. Natural Circulating Current Control

Fig. 9 shows the different currents and voltages in case the natural circulating current control method is used. The circulating current reference is now given by (16), where $I_{cT,0}^* = 20$ A. As the controller is only needed to compensate for a voltage drop over the resistance of the inductors, it has almost no influence on the firing angles, and as a result the output voltage v_L shows a regular pattern. The circulating current stays close to its reference, which guarantees that no discontinuous conduction will occur.

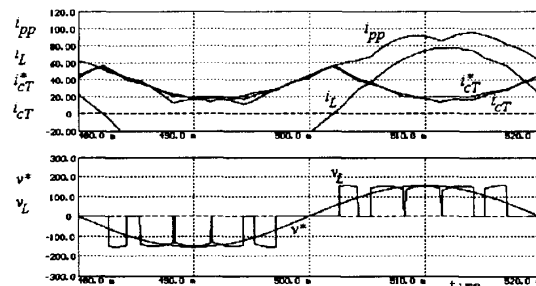

Fig. 9. Natural circulating current control.

In order to obtain a good performance also in dynamic situations, where $|\hat{i}_L|$ could increase, the value of $|\hat{i}_L|$ in (16) is not just the measured peak value of the load current. Instead, it equals this measured value limited to a certain minimum. If this minimum limit is chosen to be equal to the maximum load current which ever occurs, the load current may change suddenly from zero to its maximum without causing discontinuous conduction. If only slower changes of the load current are expected, this minimum limit can be chosen lower or zero, in order to obtain a lower circulating current at no load conditions.

V. EXPERIMENTAL RESULTS

The cycloconverter with the proposed natural circulating current control was realized and tested in a field oriented laboratory drive system. Tests were performed with different load currents in both motor and generator operation modes of both an asynchronous and a synchronous machine.

The cycloconverter was realized as indicated in Fig. 1, except that on the secondary side of the transformers capacitors were installed to compensate for a part of the reactive power consumed by the converter, which allows a more economic use of the transformers. The control circuit was realized according to the block diagram in Fig. 10 using basic analog components, except for the part which calculates the firing angles from the reference voltages. The thyristor firing circuit was a commercially available one, and required an input voltage proportional to the firing angle.

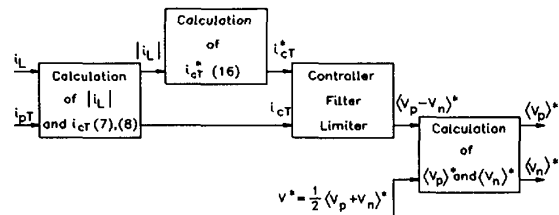

Fig. 10. Block diagram of the circulating current controller.

Fig. 11 shows the results for motor operation, with a stator current frequency of 22 Hz. Both the load current and the circulating current show a 300 Hz ripple, but due to the natural circulating current control discontinuous conduction is avoided. $I_{cT,0}^*$ was set to 12 A. The output voltage has an extra ripple compared to the simulations, which is caused by the reactive power compensating capacitors. Furthermore, the voltage is not as symmetric as in the simulations, because the period of the load voltage is now not a multiple of one sixth of the line period (3.3 ms). Finally, also the commutations in one cycloconverter phase cause a distortion of the output voltages of the other phases, but this effect is limited by the capacitors.

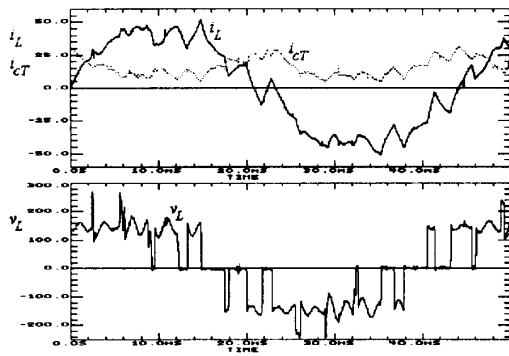

Fig. 11. Experimental result in motor operation.

In Fig. 12 the load and circulating currents and the output voltage are shown for generator operation at a frequency of 13 Hz. At this output voltage the ripple in the load current is even higher, but also in this case the control functions correctly.

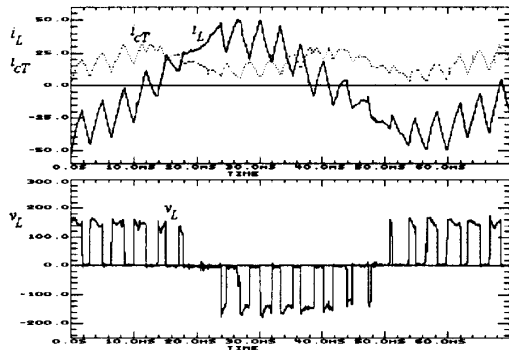

Fig. 12. Experimental result in generator operation.

VI. CONCLUSIONS

When using a cycloconverter with circulating current, it is important to assure that this current does not become discontinuous. To obtain this, circulating current control is needed. A simple proportional controller is not sufficient to obtain a constant circulating current, especially if the load current changes rapidly. If forward compensation is used to eliminate the influence of the load current, problems arise if this current contains a strong ripple component (caused by the converter output voltage).

A practical way to maintain the circulating current greater than zero, is to use the controller only to add a constant component to its natural (uncontrolled) waveform. With this natural circulating current control discontinuous conduction is avoided in all situations, so the output voltage is independent of the load current. Practical experiments with a field oriented drive system showed that even with a strong ripple in the load current the natural circulating current control functions correctly.

REFERENCES

- [1] Pelly B.R., *Thyristor phase controlled converters and cycloconverters: operation, control and performance*, New York: Wiley, 1971.
- [2] Hill W.A. en E.Y.Y Ho, I.J. Neuzil, "Dynamic behavior of cycloconverter system", *IEEE Trans. Ind. App.*, Vol. 27 (1991), No. 4, pp. 750-755.
- [3] Tamura Y. en S. Tanaka, S. Tadakuma, "Control method and upper limit of output frequency in circulating-current type cycloconverter", *Int. Semicond. Power Conv. Conf.*, Orlando, May, 1982, Conference Record, pp. 313-323.