

Rain and ice depolarisation

Citation for published version (APA):

Kamp, van de, M. M. J. L., Martellucci, A., & Paraboni, A. (2002). Rain and ice depolarisation. In *Radiowave propagation modelling for new satcom services at Ku-band and above* (pp. Ch.2.4-1/32). (ESA-SP; Vol. 1252). European Space Agency.

Document status and date:

Published: 01/01/2002

Document Version:

Publisher's PDF, also known as Version of Record (includes final page, issue and volume numbers)

Please check the document version of this publication:

- A submitted manuscript is the version of the article upon submission and before peer-review. There can be important differences between the submitted version and the official published version of record. People interested in the research are advised to contact the author for the final version of the publication, or visit the DOI to the publisher's website.
- The final author version and the galley proof are versions of the publication after peer review.
- The final published version features the final layout of the paper including the volume, issue and page numbers.

[Link to publication](#)

General rights

Copyright and moral rights for the publications made accessible in the public portal are retained by the authors and/or other copyright owners and it is a condition of accessing publications that users recognise and abide by the legal requirements associated with these rights.

- Users may download and print one copy of any publication from the public portal for the purpose of private study or research.
- You may not further distribute the material or use it for any profit-making activity or commercial gain
- You may freely distribute the URL identifying the publication in the public portal.

If the publication is distributed under the terms of Article 25fa of the Dutch Copyright Act, indicated by the "Taverne" license above, please follow below link for the End User Agreement:

www.tue.nl/taverne

Take down policy

If you believe that this document breaches copyright please contact us at:

openaccess@tue.nl

providing details and we will investigate your claim.

CHAPTER 2.4

Rain and Ice Depolarisation

Editor: Antonio Martellucci¹

Authors: Max van de Kamp², Antonio Martellucci¹, Aldo Paraboni³

¹ European Space Agency, Estec, Keplerlaan 1, Postbus 299, 2200 AG Noordwijk, The Netherlands

Tel: +31 71 565 5603, Fax: +31 71 565 4999, e-mail: Antonio.Martellucci@esa.int

² Eindhoven University of Technology, Postbus 513, 5600 MB Eindhoven, The Netherlands

Tel.: +31 40 247 2326, Fax.: +31 40 245 5197, e-mail: m.m.j.l.v.d.kamp@ele.tue.nl

³ Politecnico di Milano, CSTS, Pza Leonardo da Vinci 32, 20133 Milano, Italy

Tel. +39 2 23993586, Fax +39 2 3993413, e-mail: aparaboni@elet.polimi.it

2.4 Rain and Ice Depolarisation

The development of radio communication systems making use of wave polarisation in the 20/30 and 40/50 GHz frequency bands requires an accurate modelling of the atmospheric transfer matrix. The polarisation of the electromagnetic wave propagating in the atmosphere can be modified by the presence in the atmosphere of non-spherical particles such as raindrops and ice crystals. Rain and ice contribute in a different way to depolarisation, depending on the frequency band, the contribution of ice being more relevant as the frequency increases.

The full characterisation of the depolarising medium can be obtained by means of the atmospheric transfer matrix. The transfer matrix can be completely described, under general assumptions, using “*anisotropy*” and “*canting angle*”. As discussed in the following, these parameters are strictly related to the physical mechanisms producing depolarisation (inclined hydrometeors axis, wind shear, turbulence, etc), can be scaled in frequency and can be predicted using climatological parameters. Furthermore the ice and rain depolarisation can be assessed separately and combined on a physical basis. The “quasi-physical” parameters can either be calculated theoretically or derived from the statistical database of the measurements performed in the framework of the Olympus and Italsat propagation experiments.

The transfer matrix modelling permits to define the joint statistical distribution of depolarisation and rain attenuation (including also ice effects in the absence of rain) that is particularly required for the estimation of digital system performances.

A simpler approach, based on the average relationship between rain attenuation and cross-polar discrimination (XPD) like the one used by the ITU-R model [ITU-R, 1999], is practical, as an alternative to the transfer matrix description, when only the atmospheric XPD needs to be estimated. During the COST 255 project, the current model of ITU-R for crosspolar-discrimination has been extended up to V-Band.

Nevertheless the comparison of these models with Olympus and Italsat propagation measurements in the Ka- and V-Bands (see Chapter 2.6) has demonstrated that they can underestimate the worst cases of ice depolarisation in absence of rain or during moderate rainfalls.

The appendix contains a brief review of of polarisation, intended to simplify conversion between the different methods used to describe the polarisation of an electromagnetic wave.

2.4.1 Definition of the atmospheric transmission matrix

The effect of the atmosphere on the electromagnetic wave can be described by means of the transfer matrix \mathbf{T} [Capsoni and Paraboni, 1972], [Oguchi, 1983].

The matrix \mathbf{T} relates the input electric field, \mathbf{E}_T , to that received, \mathbf{E}_R :

$$\begin{bmatrix} E_{xr} \\ E_{yr} \end{bmatrix} = \begin{bmatrix} T_{xx} & T_{xy} \\ T_{yx} & T_{yy} \end{bmatrix} \cdot \begin{bmatrix} E_{xt} \\ E_{yt} \end{bmatrix} \quad 2.4-1$$

where

$$\begin{bmatrix} E_{xi} \\ E_{yi} \end{bmatrix} \equiv \mathbf{E}_i \quad = \text{amplitude of the transmitted/received (i = T or R) electric field along the x and y axes}$$

$$\mathbf{T} \equiv \begin{bmatrix} T_{xx} & T_{xy} \\ T_{yx} & T_{yy} \end{bmatrix} = \text{atmospheric transfer matrix using } \mathbf{x} \text{ and } \mathbf{y} \text{ polarisations}$$

T_{ij} = copolar component received on the channel employing polarisation i , when an electric field with an amplitude equal to one is transmitted on the channel employing polarisation j . (i and $j = x$ or y).

When two generic orthogonal polarisations, $E_{//}$ and E_{\perp} , are transmitted, the transfer matrix, \mathbf{T} , can be transformed into the matrix \mathbf{M} , by using:

$$\mathbf{M} = \begin{bmatrix} \cos(\alpha) & e^{-j\delta} \sin(\alpha) \\ \sin(\alpha) & -e^{-j\delta} \cos(\alpha) \end{bmatrix} \cdot \mathbf{T} \cdot \begin{bmatrix} \cos(\alpha) & \sin(\alpha) \\ e^{+j\delta} \sin(\alpha) & -e^{+j\delta} \cos(\alpha) \end{bmatrix} \quad 2.4-2$$

where:

$$E_{//} = E_0 [\cos(\alpha)\mathbf{x} + \sin(\alpha)e^{j\delta}\mathbf{y}]$$

α, δ = Parameters that describes the transmitted polarisation. (See Section 1 of the appendix).

A particular case of \mathbf{M} occurs when circular polarisation is employed. The transfer matrix, \mathbf{C} , expressed using the right, r , and left-hand, l , circular polarisation, E_r and E_l is:

$$\begin{bmatrix} E_{rr} \\ E_{lr} \end{bmatrix} = \begin{bmatrix} C_{rr} & C_{rl} \\ C_{lr} & C_{ll} \end{bmatrix} \cdot \begin{bmatrix} E_{rt} \\ E_{lt} \end{bmatrix} \quad 2.4-3$$

where:

$$\mathbf{C} \equiv \begin{bmatrix} C_{rr} & C_{rl} \\ C_{lr} & C_{ll} \end{bmatrix} = \text{Atmospheric transfer matrix using right and left hand circular polarisation}$$

$$C_{rr} = ? [T_{xx} + T_{yy}] + j(T_{yx} - T_{xy}) ; C_{ll} = ? [T_{xx} + T_{yy}] - j(T_{yx} - T_{xy})$$

$$C_{rl} = ? [T_{xx} - T_{yy}] + j(T_{yx} + T_{xy}) ; C_{lr} = ? [T_{xx} - T_{yy}] - j(T_{yx} + T_{xy})$$

The copolar term of the transfer matrix, T_{ij} , describes the fading of polarisation i , A_i , in dB:

$$\begin{aligned} A_x &= -20 \log(T_{xx}) & A_{cr} &= -20 \log(C_{rr}) \\ A_y &= -20 \log(T_{yy}) & A_{cl} &= -20 \log(C_{ll}) \end{aligned} \quad 2.4-4$$

The crosspolar discrimination, XPD_{ij} , is the ratio between the copolar component received on the channel employing polarisation j , T_{jj} , and the crosspolar component received on the channel using polarisation i , T_{ij} , when only polarisation j is transmitted:

$$\begin{aligned} XPD_{xy} &= 20 \log |T_{yy} / T_{xy}| & XPD_{rl} &= 20 \log |C_{ll} / C_{rl}| \\ XPD_{yx} &= 20 \log |T_{xx} / T_{yx}| & XPD_{lr} &= 20 \log |C_{rr} / C_{lr}| \end{aligned} \quad 2.4-5$$

where :

$$T_{ij} / T_{jj} = \rho_{ij} = \text{complex depolarisation ratio}$$

The crosspolar isolation, XPI_{ij} , is defined as the ratio between the copolar part of the signal on the channel using polarisation i , T_{ii} , and the crosspolar component of the signal received on the same

$$\begin{aligned} XPI_{xy} &= 20 \log |T_{xx}/T_{xy}|, & XPI_{xy} &= 20 \log |T_{xx}/T_{xy}| \\ XPI_{yx} &= 20 \log |T_{yy}/T_{yx}|, & XPI_{yx} &= 20 \log |T_{yy}/T_{yx}| \end{aligned} \quad 2.4-6$$

The transfer matrix \mathbf{T} can be normalised to one of its elements, e.g. T_{xx} . Therefore only a maximum of three complex parameters is actually needed to describe the transfer channel.

The two eigenvectors of the transfer matrix \mathbf{T} , defined as the **characteristic polarisations**, represent the two polarisations that propagate in the atmosphere without undergoing depolarisation [Capsoni and Paraboni, 1972; Oguchi, 1983].

If the characteristic polarisations are linear, then they are orthogonal vectors and the planes identified by the linear polarisation vectors and the propagation direction are defined as **principal planes** of the transfer channel.

In the general case, the eigenvalues of the transfer matrix \mathbf{T} are related to the propagation constants of the characteristic polarisations and are given by:

$$\begin{aligned} \Gamma_I &= \exp(-\gamma_I) = \frac{1}{2} \left[(T_{yy} + T_{xx}) + \sqrt{(T_{yy} - T_{xx})^2 + 4T_{xy}T_{yx}} \right] \\ \Gamma_{II} &= \exp(-\gamma_{II}) = \frac{1}{2} \left[(T_{yy} + T_{xx}) - \sqrt{(T_{yy} - T_{xx})^2 + 4T_{xy}T_{yx}} \right] \end{aligned} \quad 2.4-7$$

where:

γ_I, γ_{II} = propagation constants of the eigenvectors I e II, defined as characteristic polarisations.

I = Polarisation characterised by the lower attenuation or the lower phase shift.

II = Polarisation characterised by the higher attenuation or the higher phase shift.

The anisotropy of the medium, Δ , is defined as the difference between the propagation constants of the characteristic polarisations:

$$\Delta = \gamma_{II} - \gamma_I \quad 2.4-8$$

where:

$\text{Re}(\Delta)$ = Differential Attenuation of the atmosphere for the characteristic polarisations, [nep]

$\text{Im}(\Delta)$ = Differential phase shift of the atmosphere for the characteristic polarisations, [rad]

In the general case, the eigenvectors of characteristic polarisations, \mathbf{E}_I and \mathbf{E}_{II} , of the transfer matrix \mathbf{T} are elliptical polarisations and are given by:

$$\mathbf{E}_I = \left(\begin{array}{c} (T_{yy} - T_{xx}) + \sqrt{(T_{yy} - T_{xx})^2 + 4T_{xy}T_{yx}} \\ -2T_{xy} \end{array} \right); \quad \mathbf{E}_{II} = \left(\begin{array}{c} 2T_{xy} \\ (T_{yy} - T_{xx}) + \sqrt{(T_{yy} - T_{xx})^2 + 4T_{xy}T_{yx}} \end{array} \right) \quad 2.4-9$$

where:

$$\mathbf{E}_I \cdot \mathbf{E}_{II} = 0$$

The two characteristic polarisations can be described by means of the complex canting angle of eigenvector II, Φ (see Section 6 of the appendix), that is given by the following relationship:

$$\tan(\Phi) = \frac{(T_{yy} - T_{xx}) + \sqrt{(T_{yy} - T_{xx})^2 + 4T_{xy}T_{yx}}}{2T_{xy}} \quad 2.4-10$$

where:

$\text{Re}(\Phi)$ = Canting angle of the ellipse with respect x axes. $-\pi/2 < \text{Re}(\Phi) \leq +\pi/2$

$\tanh[\text{Im}(\Phi)]$ = Axial ratio of the ellipse.

The occurrence of principal planes in the atmospheric medium is revealed by the condition, $\text{Im}\{\Phi\} = 0$. In this particular case the characteristic polarisations, \mathbf{E}_I and \mathbf{E}_{II} , are two orthogonal linear polarisations, canted at an angle $\text{Re}\{\Phi\}$ with respect to the y and x axes.

2.4.2 Model of the transfer matrix

A model of the propagation of a polarised electromagnetic plane wave through a spatial distribution of non-spherical particles, can be derived under the following general assumptions:

- 1) The amplitude of the field scattered by the particles can be calculated using the Fresnel approximation.
- 2) The contribution to the transmitted field by scattering from directions different from the propagation direction of the plane wave can be ignored. (i.e. only the forward scattering by particles contributes to the transmitted field).
- 3) The shape of atmospheric particles (rain drops and ice crystals) has an axis of symmetry.
- 4) The distribution of particles is longitudinally homogeneous.

Using these assumptions the differential equation that describes the electromagnetic wave propagation can be solved, by means of the technique based on eigenvectors and eigenvalues [Capsoni et al., 1981]. It turns out that the number of complex parameters, needed to describe the transfer matrix \mathbf{T} , reduces from three to two. The medium transfer matrix, using linear polarisations x and y , is given by:

$$\mathbf{T} = \exp\left(-l \frac{\gamma_x + \gamma_y}{2}\right) \cdot \left[\cosh\left(\frac{\Delta}{2}\right) \cdot \begin{pmatrix} 1 & 0 \\ 0 & 1 \end{pmatrix} - \sinh\left(\frac{\Delta}{2}\right) \cdot \begin{pmatrix} \cos(2\Phi) & \sin(2\Phi) \\ \sin(2\Phi) & -\cos(2\Phi) \end{pmatrix} \right] \quad 2.4-11$$

where :

γ_x, γ_y = propagation constants of x and y polarisations

$\Delta = \gamma_{II} - \gamma_I$ = anisotropy of the medium.

γ_I, γ_{II} = propagation constants of characteristic polarisations I and II.

$\Phi = \Phi_R + j\Phi_I$ = complex canting angle of polarisation II

l = length of dispersion of particles.

Therefore the transfer matrix can be completely described by means of the **anisotropy of the medium**, Δ , and the **complex canting angle**, Φ .

The crosspolar discrimination of linear polarisation can be calculated using the complex depolarisation ratios (see equation 2.4-5):

$$\rho_{xy} = \frac{-\tanh\left(\frac{\Delta}{2}\right)\text{sen}(2\Phi)}{1 + \tanh\left(\frac{\Delta}{2}\right)\text{cos}(2\Phi)} ; \quad \rho_{yx} = \frac{-\tanh\left(\frac{\Delta}{2}\right)\text{sen}(2\Phi)}{1 - \tanh\left(\frac{\Delta}{2}\right)\text{cos}(2\Phi)} \quad 2.4-12$$

The medium transfer matrix \mathbf{C} , when right or left handed circular polarisation are transmitted, is given by:

$$\mathbf{C} = \exp\left(-l \frac{\gamma_x + \gamma_y}{2}\right) \cdot \left[\cosh\left(\frac{\Delta}{2}\right) \cdot \begin{pmatrix} 1 & 0 \\ 0 & 1 \end{pmatrix} - \sinh\left(\frac{\Delta}{2}\right) \cdot \begin{pmatrix} 0 & \exp(+j2\Phi) \\ \exp(-j2\Phi) & 0 \end{pmatrix} \right] \quad 2.4-13$$

Similarly the complex depolarisation ratios of circular polarisation are:

$$\rho_{rl} = -\tanh\left(\frac{\Delta}{2}\right) \exp(j2\Phi) ; \quad \rho_{lr} = -\tanh\left(\frac{\Delta}{2}\right) \exp(-j2\Phi) \quad 2.4-14$$

The propagation parameters needed for the evaluation of the atmospheric transmission matrix can be calculated using the scattering matrix of all the particles:

$$\begin{aligned} \gamma_x &= jk + \frac{2\pi}{k^2} \sum S_{xx}(f, a, \theta, \phi) \\ \gamma_y &= jk + \frac{2\pi}{k^2} \sum S_{yy}(f, a, \theta, \phi) \end{aligned} \quad 2.4-15$$

$$\begin{aligned} \Delta &= \frac{2\pi}{k^2} \sqrt{\sum (S_2 - S_1) \exp(+2j\phi) \sum (S_2 - S_1) \exp(-2j\phi)} \\ \Phi &= \frac{j}{4} \ln \left[\frac{\sum (S_2 - S_1) \exp(-2j\phi)}{\sum (S_2 - S_1) \exp(+2j\phi)} \right] \end{aligned} \quad 2.4-16$$

where:

the sum is performed over all the particles contained in the distribution

f = frequency [Hz]

a = parameter that describes the dimension of the particle (e.g. equivolumetric radius).

θ, ϕ = angles that describe the spatial orientation of the symmetry axis of each particle, with respect to the propagation direction, on longitudinal plane ($\theta, 0 < \theta \leq \pi$) and transverse plane ($\phi, -\pi/2 < \phi \leq +\pi/2$)

k = $2\pi/\lambda$ = wave-number [rad/m]

S_1, S_2 = copolar elements of the scattering matrix when polarisation 1 or 2 are transmitted.

Polarisations 1 or 2 are respectively parallel and orthogonal to the symmetry axis of the particle.

$$\left. \begin{aligned} S_{xx} &= (S_1 + S_2)/2 + \cos(2\phi)(S_2 - S_1)/2 \\ S_{yy} &= (S_1 + S_2)/2 - \cos(2\phi)(S_2 - S_1)/2 \\ S_{xy} &= S_{yx} = \sin(2\phi)(S_2 - S_1)/2 \end{aligned} \right\} = \text{Elements of the particle scattering matrix (x or y polar}^n\text{).}$$

For a general description of models to calculate the scattering matrix see [*Poiaraes Baptista, 1994*].

From the previous equations it can be derived that the characteristic polarisations are linear and the medium is characterised by the existence of principal planes of polarisation (i.e. $\text{Im}(\Phi)=0$) when one of the following conditions holds:

- 1) The scattering matrix of the particles can be calculated using the Rayleigh approximation for spheroidal particles.

- 2) The statistical distribution of the orientations of the particle symmetry axis is a symmetric function.

This general model can be further developed to describe the following particular cases:

2.4.2.1 *Fully aligned particles*

When all the particles are aligned, with their symmetry axes oriented along the direction described by the longitudinal canting angle θ_0 and the transverse canting angle ϕ_0 , the total anisotropy and the complex canting angle of the medium are given by the following relationships:

$$\Delta = \frac{2\pi}{k} l \int n(a) [S_2(f, a, \theta_0, \phi_0) - S_2(f, a, \theta_0, \phi_0)] da \quad 2.4-17$$

$$\text{Re}(\Phi) = \phi_0 ; \text{Im}(\Phi) = 0 \quad 2.4-18$$

where:

$n(a)$ = distribution of drop size.

l = length of dispersion of particles.

Therefore the characteristic polarisations are linear and canted at an angle ϕ_0 with respect to the x and y axes.

2.4.2.2 *Particles with Gaussian distribution of orientations*

When the longitudinal canting angle θ and the transverse canting angle ϕ are statistically independent and are distributed according to a normal model, the total anisotropy and the complex canting angle of the medium are given by the following relationships:

$$\Delta = r \frac{2\pi L}{k^2} \int n(a) [S_2(f, a, \theta_0, \phi_0) - S_1(f, a, \theta_0, \phi_0)] da \quad 2.4-19$$

$$\text{Re}(\Phi) = \phi_0 ; \text{Im}(\Phi) = 0 \quad 2.4-20$$

where:

$r = \frac{1}{2} [1 + \exp(-2\sigma_\theta^2)] \exp(-2\sigma_\phi^2)$ = reduction factor of the anisotropy due to misalignment of particles

θ_0, ϕ_0 = mean values of longitudinal and transverse canting angle.

$\sigma_\theta, \sigma_\phi$ = standard deviations of longitudinal and transverse canting angle.

Therefore the medium is still characterised by linear characteristic polarisations and equation 2.4-17 can be used by taking into account the reduction factor r .

2.4.2.3 *Medium composed of two different types of particle*

It is assumed that in the atmosphere there are two different distributions of particles in cascade, e.g. rain and ice. Each family is characterised by anisotropy, Δ_1 and Δ_2 , and the characteristic polarisations are linear, canted at angles ϕ_1 and ϕ_2 with respect to the x and y axes [Martellucci *et al.*, 1993; Martellucci & Paraboni, 1994; Dintelmann, 1994].

The overall transmission matrix \mathbf{T} is the product of the two transmission matrices \mathbf{T}_1 and \mathbf{T}_2 . The

$$\tanh(\Delta/2) \cong \Delta/2 \quad \text{and that} \quad T_{xx1}T_{xx2} + T_{xy1}T_{yx2} \cong T_{xx1}T_{xx2}.$$

Using these approximations the overall transfer matrix of the atmosphere, using circular polarisation, is given by :

$$\mathbf{C} = \begin{bmatrix} 1 & C_{rl} \\ C_{lr} & 1 \end{bmatrix} \quad 2.4-21$$

where:

$$C_{rl} = -\frac{d_1}{2} \exp[j(\alpha_1 + 2\phi_1)] - \frac{d_2}{2} \exp[j(\alpha_2 + 2\phi_2)]$$

$$C_{lr} = -\frac{d_1}{2} \exp[j(\alpha_1 - 2\phi_1)] - \frac{d_2}{2} \exp[j(\alpha_2 - 2\phi_2)]$$

$\Delta_i = d_i \exp(j\alpha_i) =$ anisotropy of the first or second ($i=1$ or 2) family of particles.

d_i = amplitude of anisotropy of family i

α_i = phase of anisotropy of family i .

ϕ_1, ϕ_2 = canting angle of the linear characteristic polarisation of the first and the second families of particles.

The overall anisotropy of the medium, Δ , can be obtained by inversion of equation 2.4-13:

$$\Delta = \sqrt{K_1 + K_2 + K_3} \cong 2\sqrt{C_{rl}C_{lr}} \quad 2.4-22$$

where:

$$K_1 = d_1^2 \exp(j2\alpha_1)$$

$$K_2 = d_2^2 \exp(j2\alpha_2)$$

$$K_3 = 2d_1d_2 \cdot \exp[j(\alpha_1 + \alpha_2)] \cdot \cos[2(\phi_1 - \phi_2)]$$

It is to be noted that by means of anisotropy the difference between the canting angles of the two populations, $(\phi_1 - \phi_2)$, also affects the depolarisation. When the two populations are aligned or are geometrically orthogonal, the overall anisotropy becomes:

$$\Delta = \begin{cases} \Delta_1 + \Delta_2 ; & \text{for } (\phi_1 - \phi_2) = 0 \\ \Delta_1 - \Delta_2 ; & \text{for } (\phi_1 - \phi_2) = \pm\pi/2 \end{cases} \quad 2.4-23$$

Therefore the combination of the depolarisation effects of rain and ice must take into account their relative geometrical orientation, in order to assess if the overall depolarisation is increased or reduced with respect to the separate depolarisations. This is particularly relevant during thunderstorms and at V-Band where the ice depolarisation is higher than at K-Band.

Measurements of Anisotropy and Canting Angle

The model of the atmospheric transfer matrix described in this chapter makes possible the complete assessment of atmospheric depolarisation if the anisotropy and the canting angle are known. The experimental assessment of those parameters has been performed using the dual polarisation propagation beacons of the Olympus and Italsat satellites, at 29,7 and 49.5 GHz respectively [Dintelmann, 1994; Aresu et al. 1994; Martellucci et al., 2000]. Those measurements can be used to create a new statistical database to be included in the ITU-R database of propagation experiments.

The data measured by the Olympus station located in Spino D'Adda, near Milano, are presented as an example of anisotropy and canting angle on slant paths [Aresu *et al.*, 1995]. The elevation to the satellite was 31 degrees and the polarisation tilt angle was 25 degrees.

The presence of ice at low attenuation values has been shown statistically by the Imaginary part of the overall anisotropy, Δ .

In Figure 2.4-1a the statistics are given of the real part of rain anisotropy, conditioned on attenuation. This parameter appears to be linearly related to the rain attenuation. The difference between the theoretical (discussed in Section 2.4.2.4) and the experimental values of the real part of rain anisotropy, suggest a reduction factor of about 0.6, that is in agreement with previous measurements on terrestrial path [Aresu *et al.*, 1993].

The anisotropy of ice, conditioned on attenuation, is given in Figure 2.4-1b. The theoretical maximum value of ice anisotropy derived from local radiosonde meteorological measurements is also plotted (see Section 2.4.2.4) [Paraboni *et al.*, 1997]. The model value of ice cloud anisotropy is in agreement with the mean value of measurements for attenuation values lower than 20 dB. At higher attenuations the ice anisotropy can be relevant and exhibits a correlation with the intensity of rainfall.

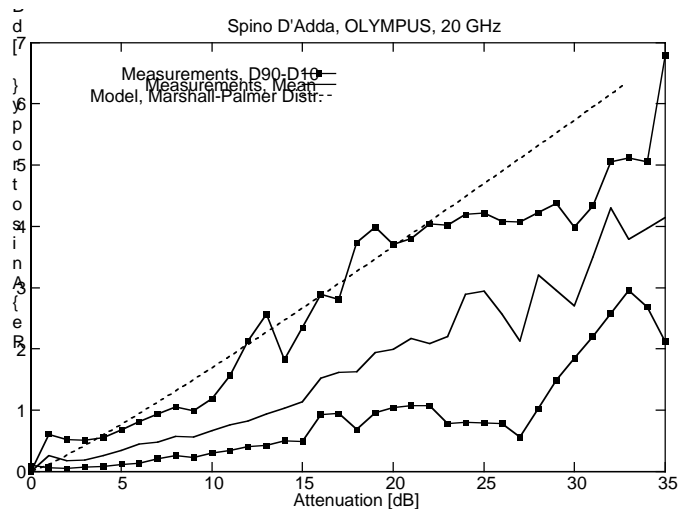

a)

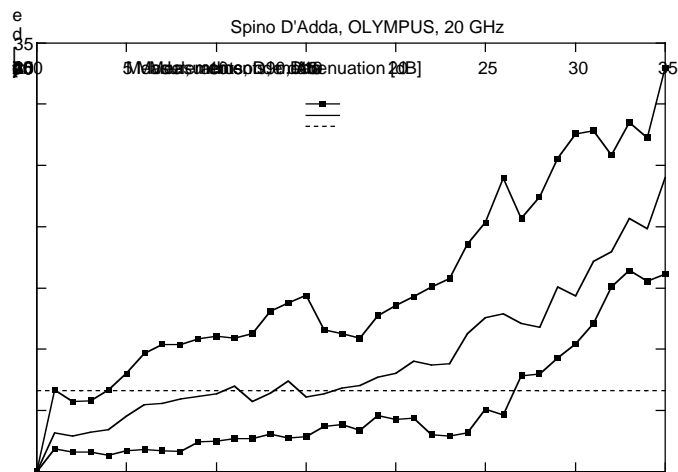

b)

Figure 2.4-1: Deciles of real part of rain anisotropy (a) and imaginary part of ice anisotropy (b)

Italsat measurements of the atmospheric transfer matrix at 49.5 GHz, performed by [Martellucci *et al.*, 2000] confirmed the Olympus results. In addition it was found that ice anisotropy at 49.5 GHz can be described by a log-normal model. The average of ice anisotropy value increases with rainfall intensity, and the standard deviation oscillates around a constant value for attenuation values ranging from 0 to 10 dB at 49.5 GHz, then it decreases for higher attenuation values.

The statistics of canting angle, with respect to local horizontal, of the raindrops and ice crystals, conditioned on attenuation values, are given in Figure 2.4-2.

As far as the rain population is concerned, there is a tendency for rain drops to stabilise during thunderstorms within a range of about 20 degrees around the horizontal, confirming similar results obtained on a terrestrial link [Aresu *et al.*, 1993].

On the contrary the measurements show that ice crystals can change orientation during thunderstorms, due to electrostatic discharges and aerodynamic effects, leading to fluctuations of more than 50°.

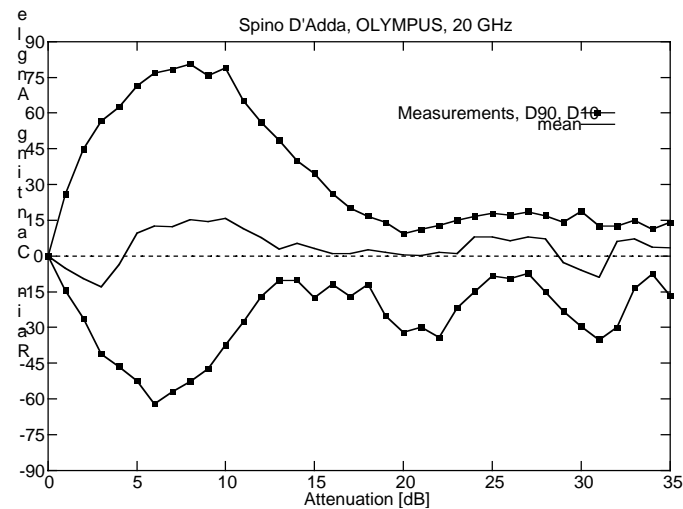

a)

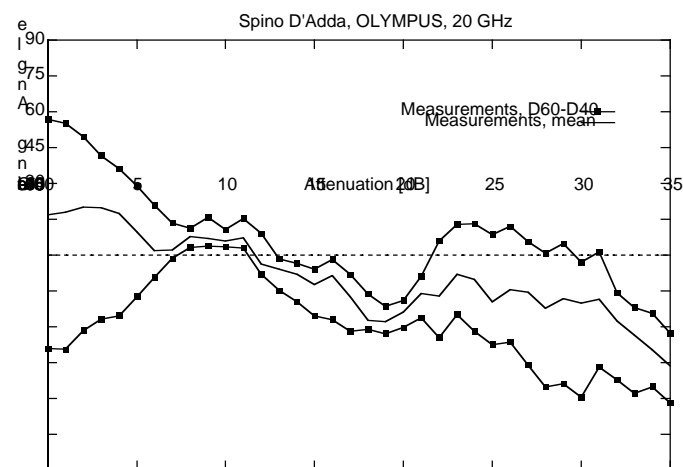

b)

Figure 2.4-2: Deciles of canting angle of rain (a) and ice (b) conditioned on attenuation measured in Spino D'Adda, using the Olympus Satellite beacon at 19.77 GHz.

2.4.2.4 *Theoretical calculation of depolarisation due to rain and ice*

The atmospheric particles that can contribute to microwave depolarisation along a slant path are raindrops, melting particles (formed by a mixture of air, water and ice) and ice crystals. According to the model illustrated in the previous chapter, the depolarisation due to atmospheric particles can be estimated theoretically, by using the appropriate microphysical parameters and models of the atmospheric particles.

As far as the melting layer is concerned, it can be expected that its thickness is lower than the characteristic size of both the ice layer and the rain cell. Therefore the depolarisation of the melting layer can be neglected, as a first approximation, when comparing the rain and ice anisotropy.

In following paragraphs, examples of modelling and calculations of the crosspolar discrimination due to rain and ice clouds in the Ka and V-Bands will be illustrated. The simultaneous occurrence of rain and ice depolarisation is also discussed and a statistical model is presented for estimating the total ice content based on the rain rate at the ground.

The parameters used for those assessments have been derived from analysis of the Olympus and Italsat propagation experiments.

Rain depolarisation

The following parameters and models have been selected for rain depolarisation:

- Water temperature = 0 °C.
- Shape of drops = oblate spheroid.
- Orientation of particle symmetry axis = parallel to the vertical direction.
- Model of rain drop size distribution = Marshall-Palmer, exponential.
- Drops are aligned , with a canting angle ranging from 5° to 45°.
- Rain cell length = 1 km.
- The water refractive index has been calculated according to [Ray, 1972].
- The scattering matrix of drops is calculated using the Oguchi's Point Matching Technique [Oguchi, 1983].

The model parameters have been verified using results from terrestrial measurements, where no ice or snow is measured, and satellite measurements, separating rain and ice [Aresu et al., 1993; Aresu et al., 1994 and Aresu et al., 1995]. The statistics of canting angle, anisotropy and rain reduction factor have been determined from those measurements.

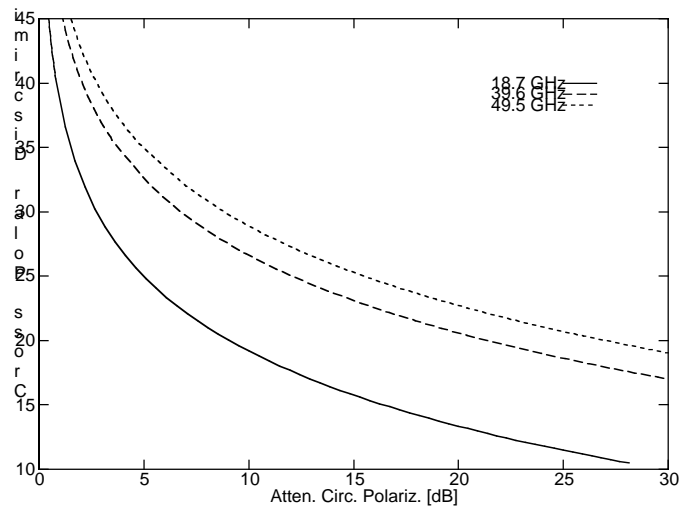

Figure 2.4-3: Rain Cross Polar Discrimination of circular polarisation as a function of attenuation at the frequencies of the Italsat propagation beacons. Link elevation = 41°.

The crosspolar discrimination as a function of the attenuation of circular polarisation is independent of the canting angle of the principal planes and is given in Figure 2.4-3. It shows the higher sensitivity of the cross-polar discrimination to the rain attenuation at Ka-Band, with respect to V-Band.

The crosspolar discrimination is lower than 25 dB when the rain attenuation at 18.7, 39.6 or 49.5 GHz is higher than 5, 10 or 15 dB, respectively.

The crosspolar discrimination of linear polarisation is affected by the canting angle of the principal planes, as depicted in Figure 2.4-4. The cross polar discrimination of the linear polarisation along the x axis as a function of attenuation, at 49.5 GHz and for a link elevation of 41°, is plotted for various canting angles of the principal planes. The crosspolar discrimination fluctuates by about 16 dB when the canting angle ranges from 5 to 45 degrees and the attenuation is higher than 16 dB.

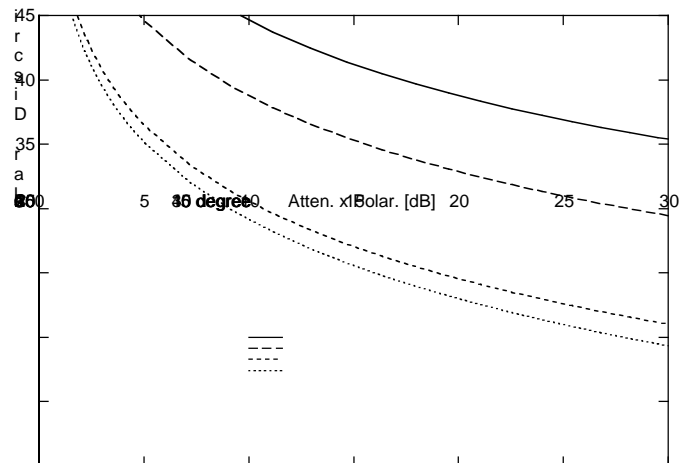

Figure 2.4-4: Rain Cross Polar Discrimination of the linear polarisation x, as a function of attenuation, at 49.5 GHz and a link elevation of 41°, for different values of the canting angle of the principal planes

Ice cloud depolarisation

In order to calculate the depolarisation due to ice clouds, the following assumptions and models

- Ice temperature = -15 °C.
- Shape of ice needles = prolate spheroid.
- Model of ice distribution size = Gamma function, Cirrostratus cloud.
- Ice density is assumed to be constant in the vertical direction.
- Scattering functions of ice crystals is calculated using the Rayleigh model.
- The ice refractive index has been calculated according to [Ray, 1972].

It can be assumed that the ice needles are maintained aligned on to the horizontal plane by aerodynamic and electrostatic effects, and can rotate freely in this plane.

When the ice crystals are completely aligned, the anisotropy depends on the rotation angle of the crystals and is higher when the rotation angle is equal to 90° and the apparent canting angle is equal to 0°. The apparent canting angle of the ice cloud is given by the projection of the symmetry axes on the plane orthogonal to the direction of propagation:

$$\phi_2(\gamma) = \arctan[-\cot(\gamma) \cdot \sin(\theta)] \quad 2.4-24$$

where:

γ = Horizontal rotation angle of the symmetry axis of the needle with respect to the propagation direction.

β = elevation angle

When the ice crystals are randomly aligned in to the horizontal plane, the anisotropy is non-zero while the apparent canting angle is equal to zero.

Using this simple model, the ice anisotropy results depend on the total ice content, I :

$$\Delta_i(I) = \Delta_{\max}(I) \sqrt{B^2 + C^2} \quad 2.4-25$$

where :

$\Delta_{\max} = j \frac{(\epsilon - 1)\pi}{\lambda} I (c_2 - c_1)$ = maximum of ice anisotropy when all the needles are aligned and $\gamma = 90$ [degrees] (the needle is transversal to the propagation direction).

I = total ice content, mm

$$B = \langle \sin(\beta) \sin[2(90 - \gamma)] \rangle$$

$$C = \langle \cos[2(90 - \gamma)] - 0.5 \cos^2(\beta) \langle \cos[2(90 - \gamma)] - 1 \rangle \rangle$$

$\langle \rangle$ = ensemble average of the parameter.

$$c_1 = \frac{1}{1 - (\epsilon - 1)a_1} ; \quad c_2 = \frac{1}{1 - (\epsilon - 1)a_2} ; \quad a_1 = \frac{m}{2(m^2 - 1)} \left[m - \frac{1}{2\sqrt{m^2 - 1}} \ln \left(\frac{m + \sqrt{m^2 - 1}}{m - \sqrt{m^2 - 1}} \right) \right] ; \quad a_2 = 1 - 2a_1$$

$\epsilon = \epsilon_r - j\epsilon_i = n^2$ = complex permittivity

$$m = a/b > 1$$

a,b = major and minor semiaxis of the particle

The values of parameters B and C are given in the following table for some particular cases.

Crystals Orientation	$\langle\gamma\rangle$ deg	B	C
Random Orientation	0	0	$0.5\cos^2(\beta)$
All Aligned	γ_0	$\sin(\beta)\sin(2\gamma_0)$	$\sin^2(\gamma_0) - \cos^2(\gamma_0)\sin^2(\beta)$
All Aligned	0	0	$-\sin^2(\beta)$
All Aligned	90	0	1

Table 2.4-1: Values of B and C parameters for calculation of ice anisotropy.

The crosspolar discrimination of circular polarisation, for various frequencies, is plotted in Figure 2.4-5 as a function of the total ice content of the cloud [Paraboni *et al.*, 1997]. The concurrent attenuation is almost equal to zero.

This shows that the ice crosspolar discrimination can drop below 30 dB, at 18.7, 39.6 and 49.5 GHz for a total ice content of 0.25, 0.15 and 0.1 mm, for a cloud thickness of 500 m. It is to be noted that ice depolarisation increases with frequency.

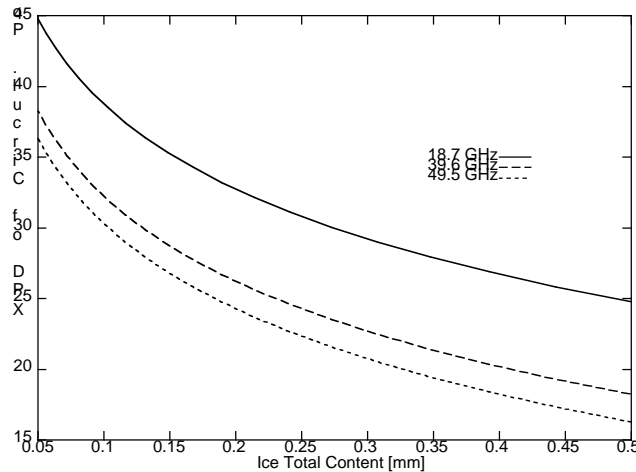

Figure 2.4-5: Crosspolar discrimination (XPD) for circular polarisation at Ka and V-Band, versus total ice content. The ice needles are aligned. Rotation angle, $\gamma = 90^\circ$. Link elevation = 41°

The value of total ice content in the absence of rain can be estimated using radiosonde measurements of the vertical profile of meteorological parameters. Statistics of the total ice content, derived from radiosonde measurements performed at various locations around the world, are given in the database described in Chapter 2.1. For example, according to this database, the value of total ice content exceeded in Europe for 1 % of the time, ranges from 0.5 to 1.2 mm.

The ice crystals can exhibit higher and faster rotational variations than raindrops, due to aerodynamic and electrostatic effects and this influences the dynamic behaviour of ice depolarisation.

The effect of the rotation of ice crystals on circular and linear polarisations is described in Figure 2.4-6. The considerable reduction of crosspolar discrimination resulting from small fluctuations in the ice crystal orientation can be evaluated, in particular for linear polarisation.

Therefore it is to be expected that ice depolarisation can be characterised by faster fluctuations than during rain depolarisation.

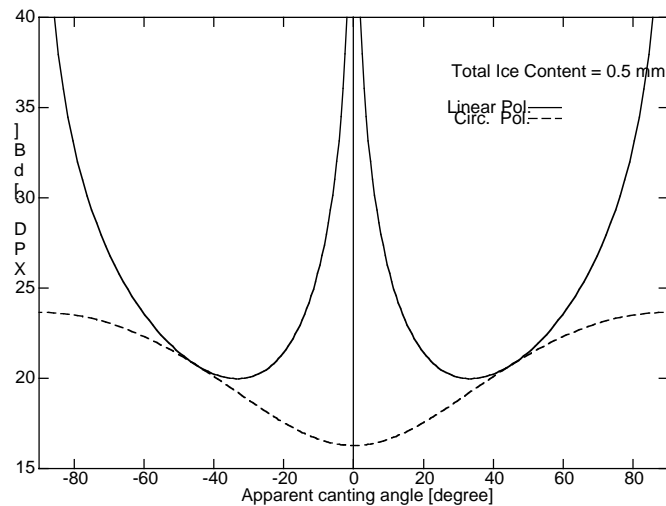

Figure 2.4-6: Cross-Polar Discrimination of linear and circular polarisations due to ice, as a function of the apparent canting angle of the ice cloud, at 50 GHz. The total ice content is 0.5 mm. The link elevation is 41°

An indirect assessment of this model is given by the similarity between the radiosonde estimation and that predicted on the basis of the Olympus and Italsat depolarisation data. As an example, the values of the total ice content in the absence of rain, estimated using the measurements of ice anisotropy and the independent radiosonde measurements, are compared in Figure 2.4-7, [Martellucci *et al.*, 2000].

The overestimation of the radiosonde calculation with respect to Italsat measurements can be ascribed to the technique used to estimate cloud ice content. The radiosonde based estimation of ice does not distinguish between spherical and deformed ice crystals. On the contrary the measurements of anisotropy along the path (like the ones performed using the Italsat beacon), are affected only by the fraction of ice crystals which are deformed.

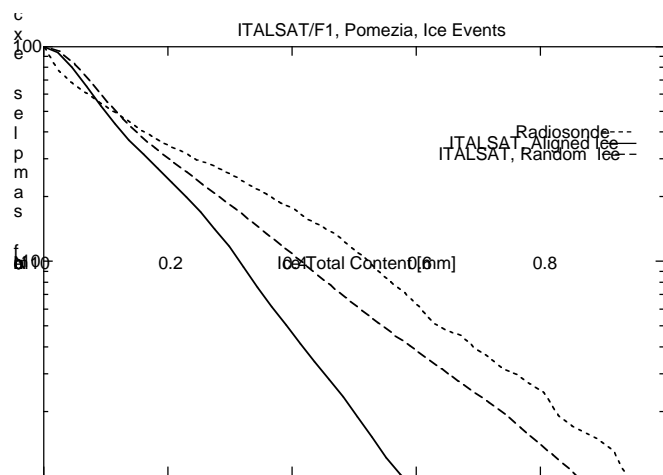

Figure 2.4-7: Cumulative distribution of the ice total content derived from Italsat measurement (using two models for particle alignment) and from local radiosonde data.

Ice depolarisation during rainfall

Using the model for the medium composed of two kinds of particles (see Section 2.4.2.3), it is possible to calculate the overall depolarisation of the atmosphere, when both rain and ice are

As discussed in the previous chapter, rain and ice anisotropy are related to the rain attenuation and to the ice content respectively. A statistical analysis of anisotropy measurements performed with Olympus and Italsat has shown that ice anisotropy appears to be related to rain intensity, with a different relationship according to the rainfall type (stratiform or convective). This observation suggests the existence of a statistical relationship, between the rain rate at the ground and the content of ice crystals at the top of the raincell, that could be used to derive ice depolarisation during rainfall, from statistics of the rain attenuation.

To this end, the measurements of the atmospheric transfer matrix performed, from April to July 1993 with an Olympus station located in Torino, Italy, have been used by [Paraboni *et al.*, 1998] to determine the joint statistics of the rain rate and the total ice content.

The relationship between rain rate and ice content was characterised by two different types of behaviour, according to the rainfall type. During stratiform rainfall the ice total content is related to the rain rate, but its values are similar to those observed in ice clouds. On the other hand the ice total content turned out to be higher during convective rainfall and it exhibited large fluctuations.

The ice total content, along the zenith is given by:

$$I_i = a_i * R + b_i \quad 2.4-26$$

where:

$i=20,50$ or 80 , indicates the values exceeded by 20%, 50% and 80% of the samples (deciles)

For rain rates, $R < 30$ mm/hr:

$$a_i = 0.0067, 0.0032, 0.0016;$$

$$b_i = 0.07, 0.04, 0.02$$

For rain rates, $R > 40$ mm/hr:

$$a_i = 0;$$

$$b_i = 0.7, 0.4, 0.2$$

This model has been assumed to be valid over the European region and has been used to calculate the values of the total ice content in the Netherlands, using as input the cumulative distribution function of rain rate measured at Eindhoven [Poiaras Baptista & Davies, 1994]. The data have been compared with estimation of the ice total content based on radiosonde measurements performed in De Bilt, The Netherlands. A fair agreement has been observed between the predicted statistics of the total ice content and the statistics of local radiosonde data (see Figure 2.4-8).

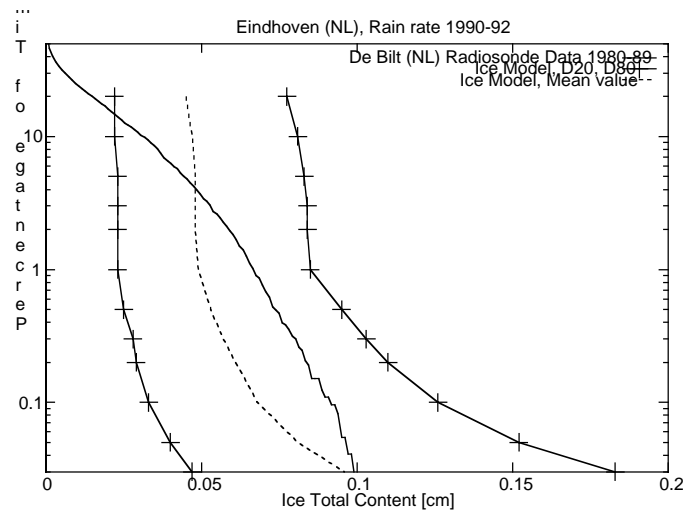

Figure 2.4-8 : Cumulative distribution function of total ice content along the zenith, derived from radiosonde data and predictions derived from the cumulative distribution function of the rain rate.

The crosspolar discrimination due to ice has been estimated by means of equation 2.4-25, assuming that ice crystals are randomly oriented, and compared with Olympus measurements of the crosspolar discrimination performed in Eindhoven at 29.77 GHz [Dintelmann, 1994; Van de Kamp, 1994]. The analysis of results in Figure 2.4-9 shows that ice depolarisation in this frequency band can contribute considerably to the overall atmospheric depolarisation, also in the presence of significant rain attenuation.

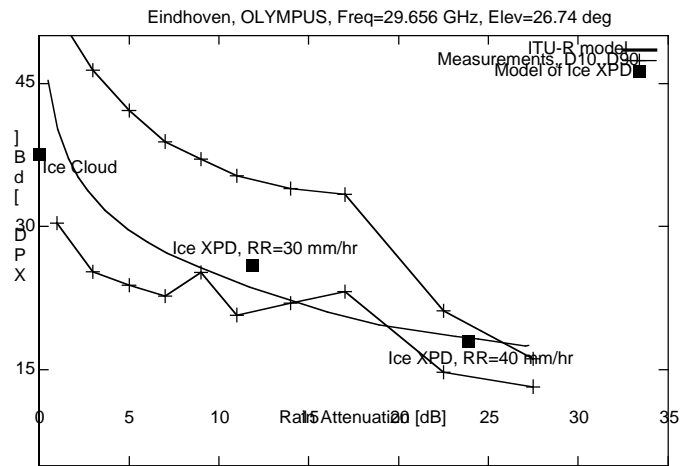

Figure 2.4-9: Joint values of the crosspolar discrimination measured at Eindhoven, the Netherlands, using the Olympus propagation beacon at 29.77 GHz. The results of the ITU-R model are also plotted.

In order to estimate the combination of ice and rain depolarisation effects, statistics are needed of the difference between canting angles of the two families (as discussed in Section 2.4.2.3). Preliminary results from the Italsat propagation experiment at V-Band indicate that this parameter can be described using the normal model, with a mean value near to zero and a standard deviation of about 50° [Martellucci et al., 2000].

2.4.3 Models of the XPD-CPA relationship in the Ku-, Ka- and V-Bands

The models described in the following paragraphs give the average relationship between the cross-

crosspolar discrimination. On the other hand these models tend to underestimate the crosspolar discrimination at 30 GHz and in the 40/50 GHz frequency band at low levels of attenuation.

Furthermore, combined statistics of depolarisation and attenuation are necessary to assess the margins of both parameters required for a certain system outage probability [Mauri *et al.*, 1987; Vasseur *et al.*, 1996]. Therefore these models are mainly to be used for estimating the CDF of the crosspolar discrimination, using the CDF of rain attenuation as input.

A description is also given of current models of the XPD-CPA relationship for rain and a new model is proposed, based on the assessment of each model against experimental results.

2.4.3.1 The ITU-R Model for Ka-Band and its extension to V-Band

This model permits the evaluation of the cumulative distribution function of crosspolar discrimination by means of an equiprobability relationship between the attenuation and the XPD. Such a relationship can be also assumed as the average relationship between the two parameters [ITU-R, 1999].

The following parameters are needed:

- A_p = the rain attenuation exceeded for the percentage of time p , dB.
- τ = tilt angle of the polarisation with respect to the local horizontal [degrees].
($\tau=45^\circ$ for circular polarisation)
- f = frequency, GHz. The model can be used in the range $8 \leq f \leq 35$ GHz
- β = link elevation in degrees. The model can be used in the range $\beta \leq 60^\circ$.

For the percentage of time p the crosspolar discrimination, due to rain, is lower than the value $XPD_{1,p}$:

$$XPD_{1,p} = U - V \log(A_p) - C_\tau - C_\beta + C_\sigma \quad 2.4-27$$

where:

$U = 30 \log(f)$ = frequency dependent term.

$$V = \begin{cases} 12.8 \cdot f^{0.19}; & 8 \leq f \leq 20 \text{ GHz} \\ 22.6 & ; \quad 20 \leq f \leq 35 \text{ GHz} \end{cases} = \text{Attenuation dependent term [Fukuchi et al., 1984].}$$

$C_\tau = 10 \cdot \log[1 - 0.484 \cdot (1 + \cos(4\tau))]$ = Polarisation dependent term.

$C_\beta = 40 \cdot \log(\beta)$ = link elevation dependent term.

$C_\sigma = 0.0052\sigma_p^2$ = parameter related to the fluctuation of the raindrops canting angle during the events and from event to event. $\sigma_p = 0^\circ, 5^\circ, 10^\circ$
when $p = 1\%, 0.1\%, 0.01\%$.

It is assumed that due to the effect of ice particles the crosspolar discrimination is lower than $XPD_{2,p}$, for the percentage of time p :

$$XPD_{2,p} = XPD_{1,p} \cdot 0.5 \cdot [0.3 + 0.1 \log(p)] \quad 2.4-28$$

The ice correction parameter has been empirically determined.

The crosspolar discrimination due to rain and ice is lower than the value $XPD_{2,p}$ for the percentage

$$XPD_p = XPD_{1,p} - XPD_{2,p} \quad 2.4-29$$

The current ITU-R model of the relationship between rain crosspolar discrimination and attenuation is based on the model originally proposed by [Nowland *et al.*, 1977].

The model has been extended to V-Band by recalculating the Olsen and Nowland coefficients to derive rain specific attenuation and phase shift from rain rate [Martellucci & Paraboni, 1998]. Those coefficients have been determined using the point matching technique of [Oguchi, 1983] for drop scattering amplitude, an oblate spheroid model of the drop shape, a water temperature of zero degrees, the model of [Ray, 1972] for water refractive index and the Marshal-Palmer rain drop size distribution. The linear regression is characterised by an error lower than 4%.

Using these coefficients the updated parameters, to be used in equation 2.4-27, for the CPA-XPD relationship at V-Band are :

$$U = 26 \log(f) ; \quad V = 20 \quad 2.4-30$$

The new parameters have been tested using the Italsat measurements carried out at Pomezia, Italy (see Chapter 2.6).

2.4.3.2 Model of Fukuchi [Fukuchi, 1990]

The model is based on the comparison between the equiprobable relationship between the crosspolar discrimination and the attenuation with the joint statistical distribution of the parameters. The correction factor δ can be used to derive the statistical distribution of XPD, $\Pr\{XPD < x\}$, from the cumulative distribution function of the copolar Attenuation, $\Pr\{A > a\}$:

$$\Pr\{XPD < x\} = \delta \cdot \Pr\{A > a\} \quad 2.4-31$$

where

$x = f(a)$; theoretical equiprobability relationship between values of XPD due to rain and values of A.

$$\delta = \frac{100}{100 - \rho} = \text{correction factor}$$

$\rho =$ probability of attenuation lower than a , conditioned on $XPD < x$.

The relationship between the correction factor δ and the copolar attenuation, that describes the effect of ice during the different atmospheric conditions, has been experimentally derived from concurrent measurements of beacon depolarisation, attenuation and radar reflectivity performed in Japan:

$$\delta_p = \begin{cases} \delta_0 & ; \quad A_p < A_1 \\ \frac{(A_p - A_1)}{(A_2 - A_1)} (1 - \delta_0) + \delta_0 & ; \quad A_1 < A_p < A_2 \\ 1 & ; \quad A_p > A_2 \end{cases} \quad 2.4-32$$

where :

A_1, A_2 = values of attenuation that correspond to the effective rain rates of 20 and 80 mm/hr.

$$\delta_0 = \frac{2}{4 - \rho}$$

rainfall events.

α = stratus rain ratio. The ratio between the number of stratus rainfall events and the total number of rain events. $\alpha < 1$
(a value of 0.8 was suggested by Fukuchi).

The percentage of time during which the crosspolar discrimination due to rain and ice is lower than XPD_p , $\text{Perc}\{XPD < XPD_p\}$, is calculated by multiplying the percentage of time, p , during which the Crosspolar Discrimination due to rain ice is lower than XPD_p , calculated according to the ITU/R model (see equation 2.4-27, and the extension up to V-Band in equation 2.4-30), for the corresponding ice correction factor δ_p , derived using the cumulative distribution function of attenuation A_p :

$$\text{Perc}\{XPD < XPD_p\} = \delta_p \cdot p \quad 2.4-33$$

The model has been checked against measurements performed in Japan with ETS-II and the BSE propagation experiments, with a good accuracy at 11.5 GHz (linear and circular polarisation) and a fixed underestimation of about 6 dB at 34 GHz. This underestimation has been ascribed to the lack of accuracy of the attenuation statistical distribution. The model has also been checked using the ITU/R database of XPD distribution, that contains data measured at frequencies from 11 to 35 GHz, and the prediction error was $\pm 10\%$ for the majority of experiments contained in the database.

2.4.3.3 *Dissanayake, Haworth, Watson analytical model* [Dissanayake et al., 1980]

The model is valid in the range 9-30 GHz and determines the relationship between rain crosspolar discrimination and attenuation by means of small amplitude and phase approximations of the rain transmission matrix.

$$XPD_{1,p} = U' - V' \log(A) - C_\beta - C'_\tau + C'_\sigma \quad 2.4-34$$

where :

$U' = 84.8 - 88.8xf^y + (0.32xf^y - 21.9)\log(f)$ = frequency dependent term ($x = 0.759$, $y = 0.08$).

$V' = 20$ = attenuation dependent term.

$C_\beta = 40 \cdot \log[\cos(\beta)]$ = link elevation dependent term.

$C'_\tau = 20 \log[\sin(2\tau)]$ = polarisation dependent term.

$C'_\sigma = 17.37\sigma^2$ = parameter related to the distribution of the raindrop canting angle.

σ = r.m.s raindrop canting angle [rad].

The depolarisation due to ice is determined, modelling the ice needles as prolate spheroids that lie in the horizontal plane and applying Rayleigh scattering. The complex depolarisation ratio of linear and circular polarisation can be simplified assuming a small argument approximation and random orientation of the needles.

$$|X_I| \approx \frac{\Delta_I}{2} \cos^2\left(\frac{\beta}{2}\right) \sin(2\tau)$$

$$\text{Arg}(X_I) \approx \frac{\pi}{2} - \frac{\Delta_I}{2} \cos^2\left(\frac{\beta}{2}\right) \cos(2\tau) \quad 2.4-35$$

$$X_c \approx \frac{i\Delta_l}{2} \cos^2\left(\frac{\beta}{2}\right) \exp(j2\tau)$$

where:

$\Delta_l = (k_1 - k_2)l$ = anisotropy of ice crystals, [rad].

$k_i = \frac{3\pi}{\lambda} V u_i$ = propagation constants of the polarisation parallel (i=1) and perpendicular (i=2) to the symmetry axis of the particle.

l = path length, m

V = total volume of ice/m³. The total ice content is V*1.

λ = wavelength, m.

u_i = anisotropy coefficients for Rayleigh scattering.

For ice needles $u_1 = 0.7228 - i0.00285$, $u_2 = 0.3468 - i0.00066$.

As discussed earlier, the effect of the melting layer is ignored, because it is assumed to be an isotropic medium, and the combined effect of rain and ice particles on the complex depolarisation ratio is determined by discarding the products of cross-polar terms. The overall depolarisation is obtained by adding the complex depolarisation ratio.

$$\begin{aligned} X_l &\approx X_l(\text{rain}) + \frac{T_{22}(\text{rain})}{T_{11}(\text{rain})} X_l(\text{ice}) \\ X_c &\approx X_c(\text{rain}) + X_c(\text{ice}) \end{aligned} \quad 2.4-36$$

where:

$T_{11}(\text{rain}), T_{22}(\text{rain})$ = Copolar terms of the rain transmission matrix

2.4.3.4 Other models of the XPD-CPA relationship due to rain

In the literature other models can be found that describe the average relationship between copolar attenuation and the crosspolar discrimination due to rain.

Chu Model [Chu, 1982]

$$XPD_{1,p} = U - 20 \log(A_p) - C_\tau - C_\beta + C_\sigma - C_x + 11.5 \quad 2.4-37$$

where :

$U = 20 \log(f)$ = frequency dependent term.

$C_\tau = 10 \cdot \log\left\{0.5 \cdot \left[1 - \cos(4\tau) \exp(-0.0024\sigma_\varphi^2)\right]\right\}$ = Polarisation dependent term.

σ_φ = standard deviation of raindrops during a thunderstorm, ($\sigma_\varphi = 3$ degrees)

$C_\beta = 40 \cdot \log[\cos(\beta)]$ = link elevation dependent term.

$C_x = 0.075 \cdot \cos^2(\beta) \cdot \cos(2\tau) \cdot A_p$ = difference between horizontal and vertical polarisation.

$C_\sigma = 0.0052\sigma_p^2$ = parameter related to the fluctuation of the raindrop canting angle during the events and from event to event.

Stutzman and Runyon model [Stutzman and Runyon, 1984]

$$XPD_{1,p} = U - 19 \log(A_p) - C_\tau - C_\beta + C_\sigma + 9.5 - \log(r) \quad 2.4-38$$

where :

$U = 17.3 \log(f)$ = frequency dependent term.

$C_\tau = 10 \cdot \log\{0.5 \cdot [1 - \cos(4\tau) \exp(-0.0024\sigma_\varphi^2)]\}$ = polarisation dependent term.

σ_φ = standard deviation of raindrops during a thunderstorm, ($\sigma_\varphi = 3$ degrees)

$C_\beta = 42 \cdot \log[\cos(\beta)]$ = link elevation dependent term.

$C_\sigma = 0.0052\sigma_p^2$ = parameter related to the fluctuation of the raindrop canting angle during the events and from event to event.

r = fraction of non-spherical raindrops (see equation 2.4-19)

Nowland, Sharofsky and Olsen (NOS) model [Nowland et al., 1977]

$$XPD_{1,p} = U - V \log(A_p) - C_\tau - C_\beta + C_\sigma + 4.1 + (V - 20) \log(L) \quad 2.4-39$$

where :

$U = 26 \log(f)$ = frequency dependent term.

$V = \begin{cases} 20; & 8 \leq f \leq 15 \text{GHz} \\ 23; & 15 \leq f \leq 35 \text{GHz} \end{cases}$ = attenuation dependent term (as ITU-R).

$C_\tau = 20 \cdot \log|\sin(2\tau)|$ = polarisation dependent term.

$C_\beta = 40 \cdot \log[\cos(\beta)]$ = link elevation dependent term.

$C_\sigma = 0.0052\sigma_p^2$ = parameter related to the fluctuation of the raindrop canting angle during the events and from event to event.

L = path length through rain (an empirical relationship has been suggested by the authors).

Van de Kamp Model [Van de Kamp, 1999]

The parameters of this model have been determined by comparing a general XPD-CPA relationship with a large group of measurements performed at 29 different locations. The frequencies of the measurements vary from 11 to 50 GHz, and the elevation angles from 3° to 50°. The polarisation angles vary from 0° to 180°, including also measurements at circular polarisation. The dependency of each parameter has been assessed separately by selecting each time a group of measurements which are equal in all but one parameter.

The general equation that has been tested, using the measurements, is:

$$XPD_{1,p} = C \log(f) - V \log(A_p) - C_\tau - D \log(\beta) + C_\sigma - C_x + S \quad 2.4-40$$

where:

the model parameters are C, V, D and S

$C \cdot \log(f) = U$ = frequency dependent term.

τ = polarisation tilt angle [degree]

C_τ = polarisation dependent term.

β = link elevation [degree]

$D \log[\cos(\beta)] = C_\beta$ = link elevation dependent term.

$C_x = 0.075 \cdot \cos^2(\beta) \cdot \cos(2\tau) \cdot A_p$ = difference between horizontal and vertical polarisation

[Chu, 1982].

$C_\sigma = 0.0052\sigma_p^2$ = parameter related to the fluctuation of the raindrop canting angle.

S = constant value.

From the separate assessment of each equation with experimental values, we have:

C	V	D	S
20 (11.6 to 29.7 GHz)	16.3	41	8

Table 2.4-2: Parameters of the Van de Kamp model of rain XPD-CPA

For the experiments at frequencies from 28.5 to 49.5 GHz it was found that the correlation is maximised for C equal to 25, in good agreement with the theoretical assessment performed in Section 2.4.3.1 (C=26).

In Figure 2.4-10, the model of equation 2.4-40 and all measurements used to perform model assessment are plotted, normalised according to the following equation:

$$XPD_{norm} = XPD - (U - C_\tau - C_\beta - C_x) \quad 2.4-41$$

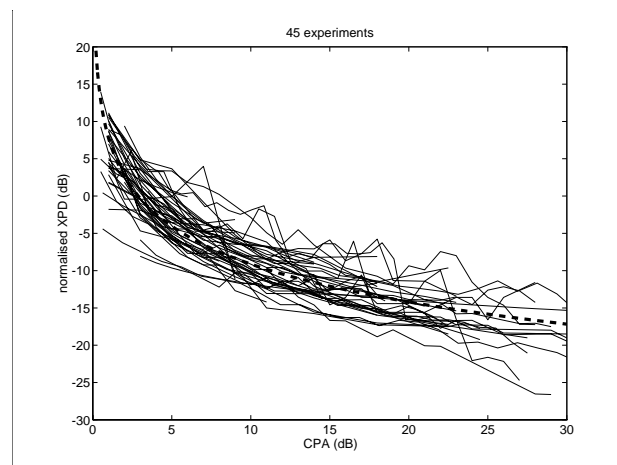

Figure 2.4-10: General test of the model: normalised XPD versus CPA, for 45 experiments; and a curve fitted to the results (thick dashed line).

2.4.4 The effect of depolarisation on radio communication systems

In order to estimate the effect of atmospheric depolarisation on radio communication systems, a distinction must be made between full co-channel frequency reuse and frequency-interleaved reuse

[Alnutt, 1989]. In Figure 2.4-11 a number of carriers are shown within the satellite transponder bandwidth, showing the frequency-polarisation allocation scheme.

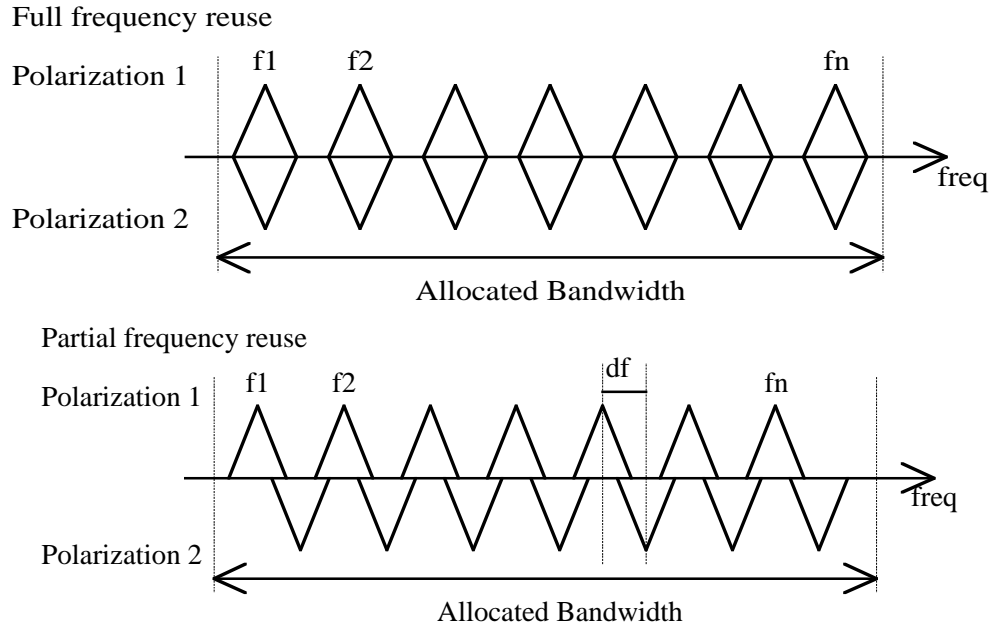

Figure 2.4-11: Spectrum utilisation for full or frequency interleaved frequency reuse. The frequency offset df describes the overlapping of the communication bands

The atmospheric depolarisation gives rise to interference between adjacent channels. This interference can be described, to a first approximation, as white noise not correlated with the signal. Therefore atmospheric depolarisation reduces the signal to noise power ratio.

The total signal to noise ratio, $(C/N)_T$, in a satellite communication links is given by:

$$\frac{1}{(C/N)_T} = \frac{1}{(C/N)_U} + \frac{1}{(C/N)_D} + \frac{1}{(C/N)_{IM}} + \frac{1}{(C/I)} \quad 2.4-42$$

where :

$(C/N)_U$ = signal to noise ratio on the uplink from ground to the satellite.

$(C/N)_D$ = signal to noise ratio on the downlink from the satellite to ground.

$(C/N)_{IM}$ = signal to noise ratio due to intermodulation products between adjacent channels.

(C/N) = signal to noise ratio due to interference between adjacent channels, e.g. atmosphere, antennas.

The terms are numerical power ratios.

The reduction of the signal to noise ratio (C/N) , with respect to the nominal level $(C/N)_{nom}$, due to the joint effect of the atmospheric depolarisation, XPD, and attenuation, A, can be determined using the following relationship:

$$C/N = -10 \log \left[10^{-\left(\frac{(C/N)_{nom} - A}{10}\right)} + 10^{-\frac{XPD}{10}} \right] \quad 2.4-43$$

These relationships and the type of modulation employed by the radiocommunication system, define a bi-dimensional set of attenuation, A , and cross-polar discrimination values, XPD , that give rise to a bit error rate (BER) that is still below the desired threshold, e.g. 10^{-6} . This set of values, D , is formed by the joint values of A and XPD that satisfy the following relationship:

$$f(A, XPD) > T(BER) \quad 2.4-44$$

where :

$f(A, XPD)$ = function of A , attenuation, and XPD , crosspolar discrimination.

$T(BER)$ = threshold value which depends on the required Bit Error Rate (BER) and on the system characteristics

The behaviour of attenuation and cross polar discrimination can be described by their joint probability function $p(A, XPD)$, where $p(A, XPD)dAdXPD$ is the probability that attenuation and crosspolar discrimination are contained in the following ranges: $A \leq a < A + dA$; $XPD \leq d < XPD + dXPD$.

Therefore the probability that the communication system is characterised by a BER lower than the required threshold, in the presence of atmospheric attenuation and crosspolar discrimination, is given by the following relationship:

$$\Pr(BER) = \iint_D p(A, XPD) dAdXPD \quad 2.4-45$$

In order to estimate the performance of a frequency reuse communication system, the joint probability density function $p(A, XPD)$ for the link site, frequency, adopted polarisation and geometry is needed [Mauri *et al.*, 1987].

2.4.5 References

[*Alnutt, 1989*]

Alnutt J., "Satellite-to-ground Radiowave Propagation", IEE Electromagnetic Waves Series, 29, 1989

[*Amaya, 1995*]

Amaya-Byrne C., "Depolarisation due to troposphere and its impact on satellite-to-earth communications", PhD Thesis, Université Catholique de Louvain-la-Neuve, Belgium, June 1995.

[*Aresu et al. 1995*]

Aresu A., A. Martellucci, A. Paraboni, R. Polonio, "Theoretical and experimental channel characterisation of spatial links at 20 and 50 GHz", Proceedings of 7th International Union of Radio Science Commission F Open Symposium "Wave Propagation and remote sensing", Ahmedabad, India, 20-24 November 1995, pp. 303-306.

[*Aresu et al. 1994*]

Aresu A., E. Damosso, A. Martellucci, L. Ordano, A. Paraboni, "Depolarisation of electromagnetic waves due to rain and ice: theory and experimental results", *Alta Frequenza*, Vol. 6, N. 6, November-December 1994, pp 70-75

[*Aresu et al. 1993*]

Aresu A., Martellucci A. and Paraboni A., "Experimental assessment of rain anisotropy and canting angle in horizontal path at 30 GHz", *IEEE Trans. on Antennas and Propagation*, Vol. 41, No. 9, pp. 1331-1335, September 1993

[*Capsoni & Paraboni, 1972*]

Capsoni C. and Paraboni A., "Depolarisation of an EM Wave traveling through a stratified aerosol of non spherical scatterers", AGARD EPP Tech. Meeting, Gausdal Norway, Sept. 1972.

[*Capsoni et al., 1981*]

Capsoni C., Paraboni A., Fedi F., Maggiori D., "A model oriented approach to measure rain induced crosspolarisation", *Ann. de Telecommunicat.*, Vol. 36, n. 1-2, Jan-Feb. 1981.

[*Chu, 1982*]

Chu, T. S., "A semi-empirical formula for microwave depolarisation versus rain attenuation on earth-space paths", *IEEE Trans. Commun.*, COM-30(12), 2550-2554, 1982.

[*Dintelmann, 1994*]

Dintelmann F. (Editor), "Reference Book on Depolarisation", OPEX- ESA WPP-083, 1994.

[*Dissanayake et al., 1980*]

Dissanayake A. W., Haworth D. P. and Watson P. A., "Analytical models for cross-polarisation on earth space radio paths for frequency range 9-30 GHz" *H., Ann. Telecommunic.*, 35, n° 11-12, 1980, pp 398-404.

[*Fukuchi, 1990*]

Fukuchi H., "Prediction of depolarisation distribution on earth-space paths", *IEE Proceedings*, Vol. 137, Pt. II, n. 6, December 1990.

[*Fukuchi et al., 1984*]

Fukuchi H., I. Ayeaka and T. Oguchi, "Improved theoretical formula for the relationship between

[ITU-R, 1999]

ITU-R, P 618-6, "Propagation data and prediction methods required for the design of Earth-space telecommunication systems", 1999,

[Martellucci *et al.*, 1993]

Martellucci A., Mauri M. and Paraboni A., "The physical basis of depolarisation", Proceedings of Olympus Utilisation Conference, (Sevilla, Spain), 20-22 April 1993, pp. 573-581.

[Martellucci & Paraboni, 1994]

Martellucci A. and Paraboni A., "Modelling of Depolarisation due to Hydrometeors: Utilisation of multipolarisation radiowave beacon for estimation of quasi-physical parameters", Proc. of PIERS 94, ESA, Noordwijk, The Netherlands, July 11-15 1994.

[Martellucci & Paraboni, 1998]

Martellucci A. and A. Paraboni, "Test and Development of Models of Atmospheric Crosspolar Discrimination for Satellite Communication Systems at Ka- and V-Band", Proceed. of the first international Workshop on Radiowave Propag. Model. for SatCom Serv. at Ku-band and above, Estec, Noordwijk, The Netherlands, 28-29 October 1998

[Martellucci *et al.*, 2000]

Martellucci A., Paraboni A. and Filipponi M. "Measurements and modeling of rain and ice depolarisation on spatial links in the Ka- and V-Bands", invited paper, AP2000 Millennium Conference on Antennas and Propagation, Davos, Switzerland, 9-14 April 2000.

[Mauri *et al.*, 1987]

Mauri M., A. Paraboni and D. Tarducci, "Depolarisation Measurements and their use in the determination of dual polarisation links performance", *Alta Frequenza*, Vol. LVI, No. 1-2, Jan.-Apr. 1987

[Nowland *et al.*, 1977]

Nowland W.L., Olsen R. L., Shkarofsky, "Theoretical relationship between rain depolarisation and attenuation", *Electronics Letters*, Vol. 13, No. 22, pp 676-678, 27 October 1977

[Oguchi, 1983]

Oguchi T., "Electromagnetic wave propagation and scattering in rain and other hydrometeors", *Proc. IEEE*, Vol. 71, No. 9, pp. 1029-1078, September 1983.

[Paraboni *et al.* 1997]

Paraboni A., A. Martellucci and R. Polonio, "A probabilistic model of rain and ice depolarisation based on the experimental estimation of the atmospheric ice content", *Proc SBMO/IEEE International Microwave and Optoelectronics Conference*, Natal, Brazil, 11-14 August 1997, pp 707-712

[Paraboni *et al.*, 1998]

Paraboni A., A. Martellucci, R. Polonio, "Statistical Modelling of Depolarisation due to Rain and Ice During Thunderstorms Based on the Italsat and Olympus Measurements", *Proc. 8th URSI Commission F Triennial Open Symposium*, Aveiro, Portugal, 22-25 September 1998, pp. 288-291.

[Poiars Baptista & Davies, 1994]

Poiars Baptista, J.P.V. and Davies P. G. (Editors), "OPEX: Reference Book on Attenuation measurements and prediction", ESA WPP-83, November 1994.

[*Poiares Baptista, 1994*]

Poiares Baptista J.P.V. (Editor), "Reference Book on Radar", OPEX- ESA WPP-083, November 1994.

[*Ray, 1972*]

Ray P. S., "Broad Band Complex refractive index of ice and water", Applied Optics, Vol. 11, No. 8, 1972.

[*Stutzman and Runyon, 1984*]

Stutzman, W. L., and D. L. Runyon, "The relationship of rain- induced cross-polarisation discrimination to attenuation for 10 to 30 GHz earth-space radio links", IEEE Trans. Antennas Propagat., AP-32(7), 705-710, 1984.

[*Van de Kamp, 1999*]

Van de Kamp M. (1999), "Depolarisation due to rain: the XPD-CPA relation", Int. J. Sat. Com., Vol. 9, Issue 3, pp. 285-301, 2001.

[*Vasseur et al., 1996*]

Vasseur, H., I. Adams, C. Amaya, and D. Vanhoenacker (1994), "Comparison of Yearly Statistics with CCIR Prediction Methods", Proceedings of 21st Meeting of Olympus Propagation Experimenters, OPEX XXI, Louvain-la-Neuve, Belgium, May 1994, 80-89.

2.4.6 Appendix to Chapter 2.4: Description of Polarisation

A plane wave is assumed, propagating along the z direction. The complex amplitude of the electric field is $\mathbf{E} = E_x \mathbf{x} + E_y \mathbf{y}$, where xyz is a left hand reference system. An $\exp(+j\omega t)$ time convention is assumed and is suppressed.

2.4.6.1 Complete description of the electric field

The electric field is given by:

$$\begin{aligned} E_x &= a_x e^{j\delta_x} \\ E_y &= a_y e^{j\delta_y} \end{aligned} \quad \text{A-1}$$

The state of polarisation is described by the parameters a_x , a_y and δ , where: $\delta = \delta_y - \delta_x$, $-\pi < \delta \leq \pi$.

Polarisation	a_x	a_y	δ
Linear	(0, +00)	(0, +00)	$m\pi$
Linear X	0	(0, +00)	$m\pi$
Linear Y	(0, +00)	0	$m\pi$
Linear $\pm 45^\circ$	$a_x = \pm a_y$	$a_x = \pm a_y$	$m\pi$
Right Handed Circular	$a_x = a_y$	$a_x = a_y$	$-\frac{\pi}{2} + 2m\pi$
Left Handed Circular	$a_x = a_y$	$a_x = a_y$	$+\frac{\pi}{2} + 2m\pi$

Table A-1: State of polarisation according to the complete description of the electric field

where m is an integer.

2.4.6.2 Reduced Parameters of the Electric Field

The electric field can be described as:

$$\mathbf{E} = E_0 [\cos(\alpha) \mathbf{x} + \sin(\alpha) e^{j\delta} \mathbf{y}] \quad \text{A-2}$$

The state of polarisation is described by the parameters α and δ , where $0 \leq \alpha \leq \pi/2$: $-\pi < \delta \leq \pi$

Polarisation	α	δ
Linear X	0	π
Linear Y	$\pi/2$	0
Linear $\pm 45^\circ$	$\pi/4$	0, π
Right Handed Circular	$\pi/4$	$-\pi/2$
Left Handed Circular	$\pi/4$	$+\pi/2$

Table A-2: State of polarisation described using the reduced parameters of the electric field.

2.4.6.3 *Ellipse of polarisation*

The ellipse of polarisation of the electric field can be described using the length of the semiaxes, a and b , the sense of rotation of the electric field along the ellipse and the canting of the polarisation ellipse with respect to x axis.

- a = length of the major semiaxis of the ellipse
 b = length of the minor semiaxis of the ellipse
 $r = (b/a)$ = axial ratio of the ellipse. $0 \leq r < +\infty$
 $\chi = \pm \arctan(r)$ = ellipticity, (+ = left handed polarisation, - = right handed polarisation).
 $-\pi/4 \leq \chi \leq +\pi/4$
 ψ = Canting of the ellipse with respect x axis; $-\pi/2 < \psi \leq +\pi/2$.

These parameters can be calculated using the following relationships :

$$a = \frac{1}{2} \left[E_x^2 + a_y^2 + \sqrt{a_x^4 + a_y^4 + 2a_x^2 a_y^2 \cos(2\delta)} \right] \quad \text{A-3}$$

$$b = \frac{1}{2} \left[E_x^2 + a_y^2 - \sqrt{a_x^4 + a_y^4 + 2a_x^2 a_y^2 \cos(2\delta)} \right] \quad \text{A-4}$$

$$\tan(2\psi) = \tan(2\alpha) \cos(\delta) \quad \text{A-5}$$

Polarisation	χ	ψ
Linear	0	$(0, \pi/2]$
Linear X	0	0
Linear Y	0	$\pi/2$
Linear $\pm 45^\circ$	0	$\pm\pi/4$
Right Handed Circular	$-\pi/4$	not defined
Left Handed Circular	$+\pi/4$	not defined

Table A-3.: State of polarisation described using the ellipse of polarisation.

2.4.6.4 *Stokes' Parameters*

The Stokes' parameters, S_0 , S_1 , S_2 , and S_3 , are defined by the following relationships:

$$\begin{aligned}
 S_0 &\equiv a_x^2 + a_y^2 = a^2 = S_1^2 + S_2^2 + S_3^2 \\
 S_1 &\equiv a_x^2 - a_y^2 = a^2 \cos(2\alpha) = a^2 \cos(2\chi) \cos(2\psi) \\
 S_2 &\equiv 2a_x a_y \cos(\delta) = a^2 \cos(2\alpha) \cos(\delta) = a^2 \cos(2\chi) \sin(2\psi) \\
 S_3 &\equiv 2a_x a_y \sin(\delta) = a^2 \sin(2\alpha) \sin(\delta) = a^2 \sin(2\chi)
 \end{aligned} \quad \text{A-6}$$

The vector $\mathbf{S} = (S_1, S_2, S_3)$ can be used to describe the polarisation. The extremes of this vector are located on a sphere, that is called the Poincaré sphere, whose radius is equal to S_0 . Orthogonal polarisations are described by opposite Stokes' vectors, making the identification simple.

Polarisation	\mathbf{S}
Linear	$(S_1, S_2, 0)$
Linear X	$(S_0, 0, 0)$
Linear Y	$(-S_0, 0, 0)$
Linear $\pm 45^\circ$	$(0, \pm S_0, 0)$
Right Handed Circular	$(0, 0, -S_0)$
Left Handed Circular	$(0, 0, S_0)$

Table A-4: State of polarisation described using the Stokes' parameters.

2.4.6.5 Complex Polarisation Factor

The complex polarisation ratio, p , is the ratio between the component of the electrical field:

$$p = \frac{E_y}{E_x} = \tan(\alpha) e^{j\delta} \quad \text{A-7}$$

This complex parameter represents the stereographic projection of a point on the Poincaré sphere on the plane orthogonal to axis S_1 , with $\text{Re}(p)$ parallel to S_2 and $\text{Im}(p)$ parallel to S_3 .

Polarisation	$\text{Re}(p)$	$\text{Im}(p)$
Linear	$[0, +\infty)$	0
Linear X	0	0
Linear Y	∞	0
Linear $\pm 45^\circ$	± 1	0
Right Handed Circular	0	-1
Left Handed Circular	0	+1

Table A-5: State of polarisation described using the complex polarisation factor.

2.4.6.6 Complex canting angle of the polarisation ellipse

The complex canting angle of the polarisation is given by the following relationship:

$$\tan(\Phi) = p \quad \text{A-8}$$

This parameter is related to the parameters of the polarisation ellipse by the following relationships:

$$\text{Re}(\Phi) = \psi = \text{canting angle of the ellipse with respect x axis. } -\pi/2 < \text{Re}(\Phi) \leq +\pi/2$$

$$r \equiv a/b = \tanh[\text{Im}(\Phi)] = \text{axial ratio of the ellipse. } 0 \leq r < +\infty$$

2.4-32

Polarisation	Re(Φ)	Im(Φ)
Linear	$(0, \pi/2]$	0
Linear X	0	0
Linear Y	$\pi/2$	0
Linear $\pm 45^\circ$	$\pm \pi/4$	0
Right Handed Circular	0	$-\infty$
Left Handed Circular	0	$+\infty$

Table A-6: State of polarisation described using the complex canting angle.