

Process mining with the HeuristicsMiner algorithm

Citation for published version (APA):

Weijters, A. J. M. M., Aalst, van der, W. M. P., & Alves De Medeiros, A. K. (2006). *Process mining with the HeuristicsMiner algorithm*. (BETA publicatie : working papers; Vol. 166). Technische Universiteit Eindhoven.

Document status and date:

Published: 01/01/2006

Document Version:

Publisher's PDF, also known as Version of Record (includes final page, issue and volume numbers)

Please check the document version of this publication:

- A submitted manuscript is the version of the article upon submission and before peer-review. There can be important differences between the submitted version and the official published version of record. People interested in the research are advised to contact the author for the final version of the publication, or visit the DOI to the publisher's website.
- The final author version and the galley proof are versions of the publication after peer review.
- The final published version features the final layout of the paper including the volume, issue and page numbers.

[Link to publication](#)

General rights

Copyright and moral rights for the publications made accessible in the public portal are retained by the authors and/or other copyright owners and it is a condition of accessing publications that users recognise and abide by the legal requirements associated with these rights.

- Users may download and print one copy of any publication from the public portal for the purpose of private study or research.
- You may not further distribute the material or use it for any profit-making activity or commercial gain
- You may freely distribute the URL identifying the publication in the public portal.

If the publication is distributed under the terms of Article 25fa of the Dutch Copyright Act, indicated by the "Taverne" license above, please follow below link for the End User Agreement:

www.tue.nl/taverne

Take down policy

If you believe that this document breaches copyright please contact us at:

openaccess@tue.nl

providing details and we will investigate your claim.

Process Mining with the HeuristicsMiner Algorithm

A.J.M.M. Weijters, W.M.P. van der Aalst, and A.K. Alves de Medeiros

Department of Technology Management, Eindhoven University of Technology
P.O. Box 513, NL-5600 MB, Eindhoven, The Netherlands.

{w.m.p.v.d.aalst,a.k.medeiros,a.j.m.m.weijters}@tm.tue.nl

Abstract. The basic idea of process mining is to extract knowledge from event logs recorded by an information system. Until recently, the information in these event logs was rarely used to analyze the underlying processes. Process mining aims at improving this by providing techniques and tools for discovering process, organizational, social, and performance information from event logs. Fuelled by the omnipresence of event logs in transactional information systems (cf. WFM, ERP, CRM, SCM, and B2B systems), process mining has become a vivid research area [1, 2]. In this paper we introduce the challenging process mining domain and discuss a heuristics driven process mining algorithm; the so-called “HeuristicsMiner” in detail. HeuristicsMiner is a practical applicable mining algorithm that can deal with noise, and can be used to express the main behavior (i.e. not all details and exceptions) registered in an event log. In the experimental section of this paper we introduce benchmark material (12.000 different event logs) and measurements by which the performance of process mining algorithms can be measured.

Keywords: Knowledge Discovering, Process Mining, process mining benchmark, Business Process Intelligence.

1 Process Mining

Within organizations there has been a shift from *data* orientation to *process* orientation. By process we mean the way an organization arranges their work and recourses, for instance the order in which tasks are performed and which group of people are allowed to perform specific tasks. Sometimes, organizations have very explicit process descriptions of the way the work is organized and this description is supported by a process aware information system like, for instance, a workflow management system (WFM). But even if there are explicit descriptions of the way the work should be done, the practical way of working can differ considerably from the prescribed way of working. Other times, there is no, or only a very immature process description available. However, in many situations it is possible to gather information about the processes as they take place. For instance, in many hospitals, information about the different treatments of a patient are registered (date, time, treatment, medical staff) for, reasons like

financial administration. However, this kind of information in combination with some mining techniques can also be used to get more insight in the health care process [6]. Any information system using transactional systems such as ERP, CRM, or workflow management systems will offer this information in some form. Note that we do not assume the presence of a workflow management system. The only assumption we make, is that it is possible to construct event logs with event data. These event logs are used to construct a process specification, which adequately models the behavior registered. We use the term *process mining* for the method of distilling a structured process description from a set of real executions.

As mentioned, the goal of process mining is to extract information about processes from transaction logs [1]. We assume that it is possible to record events such that (i) each event refers to an *activity* (i.e., a well-defined step in the process), (ii) each event refers to a *case* (i.e., a process instance), (iii) each event can have a *performer* also referred to as *originator* (the person executing or initiating the activity), and (iv) events have a *time stamp* and are totally ordered. Table 1 shows an example of a log involving 19 events, 5 activities, and 6 originators. In addition to the information shown in this table, some event logs contain more information on the case itself, i.e., data elements referring to properties of the case (i.e. in an hospital information system, age, sex, diagnose, etc. of a patient).

Event logs such as the one shown in Table 1 are used as the starting point for mining. We distinguish three different perspectives: (1) the process perspective, (2) the organizational perspective and (3) the case perspective. The *process perspective* focuses on the control-flow, i.e., the ordering of activities. The goal of mining this perspective is to find a good characterization of all possible paths, expressed in terms of, for instance, a Petri net [9]. The *organizational perspective* focuses on the originator field, i.e., which performers are involved in performing the activities and how they are related. The goal is to either structure the organization by classifying people in terms of roles and organizational units or to show relations between individual performers (i.e., build a social network [10]). The *case perspective* focuses on properties of cases. Cases can be characterized by their path in the process or by the originators working on a case. However, cases can also be characterized by the values of the corresponding data elements. For example, if a case represents a specific treatment of patients in a hospital it may be interesting to know the differences in throughput times between smokers and non-smokers.

To illustrate the first perspective consider Figure 1. The log shown in Table 1 contains information about five cases (i.e., process instances). The log shows that for four cases (1, 2, 3, and 4) the activities A, B, C, and D have been executed. For the fifth case only three activities have been executed: activities A, E, and D. Each case starts with the execution of A and ends with the execution of D. If activity B is executed, then also activity C is executed. However, for some cases activity C is executed before activity B. Based on the information shown in Table 1 and by making some assumptions about the completeness of the log

case id	activity id	originator	time stamp
case 1	activity A	John	9-3-2004:15.01
case 2	activity A	John	9-3-2004:15.12
case 3	activity A	Sue	9-3-2004:16.03
case 3	activity B	Carol	9-3-2004:16.07
case 1	activity B	Mike	9-3-2004:18.25
case 1	activity C	John	10-3-2004:9.23
case 2	activity C	Mike	10-3-2004:10.34
case 4	activity A	Sue	10-3-2004:10.35
case 2	activity B	John	10-3-2004:12.34
case 2	activity D	Pete	10-3-2004:12.50
case 5	activity A	Sue	10-3-2004:13.05
case 4	activity C	Carol	11-3-2004:10.12
case 1	activity D	Pete	11-3-2004:10.14
case 3	activity C	Sue	11-3-2004:10.44
case 3	activity D	Pete	11-3-2004:11.03
case 4	activity B	Sue	11-3-2004:11.18
case 5	activity E	Clare	11-3-2004:12.22
case 5	activity D	Clare	11-3-2004:14.34
case 4	activity D	Pete	11-3-2004:15.56

Table 1. An event log.

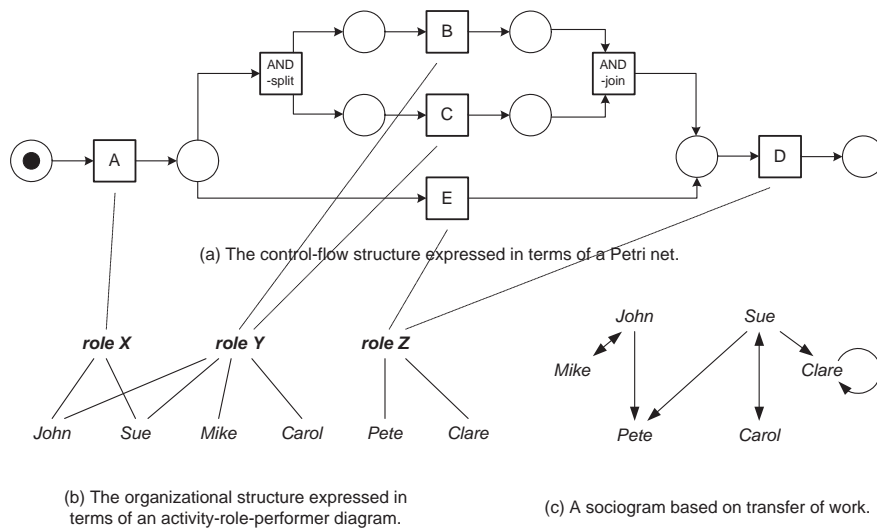

Fig. 1. Some mining results for the process perspective (a) and organizational (b and c) perspective based on the event log shown in Table 1.

(i.e., assuming that the cases are representative and a sufficient large subset of possible behaviors has been observed), we can deduce the process model shown in Figure 1(a). The model is represented in terms of a Petri net. The Petri net starts with activity A and finishes with activity D. These activities are represented by transitions. After executing A there is a choice between either executing B and C concurrently (i.e., in parallel or in any order) or just executing activity E. To execute B and C in parallel two non-observable activities (AND-split and AND-join) have been added. These activities have been added for routing purposes only and are not present in the event log. Note that for this example we assume that two activities are concurrent if they appear in any order.

Figure 1(a) does not show any information about the organization, i.e., it does not use any information concerning the people executing activities. Information about performers of activities however, is included in Table 1. For example, from the log we can deduce that (i) activity A is executed by either John or Sue, (ii) activity B is executed by John, Sue, Mike or Carol, (iii) C is executed by John, Sue, Mike or Carol, (iv) D is executed by Pete or Clare, and (v) E is executed by Clare. We could indicate this information in Figure 1(a). The information could also be used to “guess” or “discover” organizational structures. For example, a guess could be that there are three roles: X, Y, and Z. For the execution of A role X is required and John and Sue have this role. For the execution of B and C role Y is required and John, Sue, Mike and Carol have this role. For the execution of D and E role Z is required and Pete and Clare have this role. For five cases these choices may seem arbitrary but for larger data sets such inferences capture the dominant roles in an organization. The resulting “activity-role-performer diagram” is shown in Figure 1(b). The three “discovered” roles link activities to performers. Figure 1(c) shows another view on the organization based on the transfer of work from one individual to another, i.e., not focussing on the relation between the process and individuals but on relations among individuals (or groups of individuals). Consider for example Table 1. Although Carol and Mike can execute the same activities (B and C), Mike is always working with John (cases 1 and 2) and Carol is always working with Sue (cases 3 and 4). Probably Carol and Mike have the same role but based on the small sample shown in Table 1 it seems that John isn’t working with Carol and Sue isn’t working with Carol.¹ These examples show that the event log can be used to derive relations between performers of activities, thus resulting in a sociogram. For example, it is possible to generate a sociogram based on the transfers of work from one individual to another as is shown in Figure 1(c). Each node represents one of the six performers and each arc represents that there has been a transfer of work from one individual to another. The definition of “transfer of work from R1 to R2” is based on whether, in the same case, an activity executed by R1 is directly followed by an activity executed by R2. For example, both in case 1 and 2 there is a transfer from John to Mike. Figure 1(c) does not show frequencies. However, for analysis purposes these frequencies can be added. The arc from John

¹ Clearly the number of events in Table 1 is too small to establish these assumptions accurately. However, real event logs will contain thousands or more events.

to Mike would then have weight 2. Typically, we do not use absolute frequencies but weighted frequencies to get relative values between 0 and 1. Figure 1(c) shows that work is transferred to Pete but not vice versa. Mike only interacts with John and Carol only interacts with Sue. Clare is the only person transferring work to herself.

Focusing on the third perspective (i.e. the case perspective) is more interesting when also data elements are logged but these are not listed in Table 1. The case perspective looks at the case as a whole and tries to establish relations between the various properties of a case. Note that some of the properties may refer to the activities being executed, the performers working on the case, and the values of various data elements linked to the case. Using traditional data mining algorithms it would for example be possible to search for rules that predict the handling time of cases.

Orthogonal to the three perspectives (process, organization, and case), the result of a mining effort may refer to *logical* issues and/or *performance* issues. For example, process mining can focus on the logical structure of the process model (e.g., the Petri net shown in Figure 1(a)) or on performance issues such as flow time. For mining the organizational perspective, the emphasis can be on the roles or the social network (cf. Figure 1(b) and (c)) or on the utilization of performers or execution frequencies. To address the three perspectives and the logical and performance issues a set of plug-ins has been developed for the ProMframework [5] These plug-ins share a common XML format. For more details about the ProMframework, its plug-ins, and the common XML-format, we refer to www.processmining.org.

In this paper we focus on the process perspective. In fact, we consider a specific algorithm: the HeuristicsMiner-algorithm. In the next section (Section 2) we present the details of the HeuristicsMiner-algorithm. Section 3 is the experimental section in which we describe the benchmark material (12.000 different event logs), process and event log characteristics, and measurements by which the performance of process mining algorithms can be measured.

2 Process mining with the HeuristicsMiner algorithm

The HeuristicsMiner Plug-in mines the control-flow perspective of a process model. To do so, it only considers the order of the events within a case. In other words, the order of events among cases isn't important. For instance for the log in Tabletablog only the fields case id, time stamp and activity are considered during the mining. The timestamp of an activity is used to calculate these ordering. In Table 1 it is important that for case 1 activity A is followed by B within the context of case 1 and not that activity A of case 1 is followed by activity A of case 2. Therefore, we define an event log as follows. Let T be a set of activities. $\sigma \in T^*$ is an *event trace*, i.e., an arbitrary sequence of activity identifiers. $W \subseteq T^*$ is an *event log*, i.e., a multiset (bag) of event traces. Note that since W is a multiset, every event trace can appear more than once in a log. In practical mining tools frequencies become important. If we use this nota-

tion to describe the log shown in Table 1 we obtain the multiset $W = [ABCD, ABCD, ACBD, ACBD, AED]$.

To find a process model on the basis of an event log, the log should be analyzed for causal dependencies, e.g., if an activity is always followed by another activity it is likely that there is a dependency relation between both activities. To analyze these relations we introduce the following notations. Let W be an event log over T , i.e., $W \subseteq T^*$. Let $a, b \in T$:

1. $a >_W b$ iff there is a trace $\sigma = t_1 t_2 t_3 \dots t_n$ and $i \in \{1, \dots, n-1\}$ such that $\sigma \in W$ and $t_i = a$ and $t_{i+1} = b$,
2. $a \rightarrow_W b$ iff $a >_W b$ and $b \not>_W a$,
3. $a \#_W b$ iff $a \not>_W b$ and $b \not>_W a$, and
4. $a \parallel_W b$ iff $a >_W b$ and $b >_W a$,
5. $a >>_W b$ iff there is a trace $\sigma = t_1 t_2 t_3 \dots t_n$ and $i \in \{1, \dots, n-2\}$ such that $\sigma \in W$ and $t_i = a$ and $t_{i+1} = b$ and $t_{i+2} = a$,
6. $a >>>_W b$ iff there is a trace $\sigma = t_1 t_2 t_3 \dots t_n$ and $i < j$ and $i, j \in \{1, \dots, n\}$ such that $\sigma \in W$ and $t_i = a$ and $t_j = b$.

Consider the event log $W = \{ABCD, ABCD, ACBD, ACBD, AED\}$ (i.e., the log shown in Table 1). The first relation $>_W$ describes which activities appeared in sequence (one directly following the other). Clearly, $A >_W B$, $A >_W C$, $A >_W E$, $B >_W C$, $B >_W D$, $C >_W B$, $C >_W D$, and $E >_W D$. Relation \rightarrow_W can be computed from $>_W$ and is referred to as the *(direct) dependency relation* derived from event log W . $A \rightarrow_W B$, $A \rightarrow_W C$, $A \rightarrow_W E$, $B \rightarrow_W D$, $C \rightarrow_W D$, and $E \rightarrow_W D$. Note that $B \not\rightarrow_W C$ because $C >_W B$. Relation \parallel_W suggests concurrent behavior, i.e., potential parallelism. For log W activities B and C seem to be in parallel, i.e., $B \parallel_W C$ and $C \parallel_W B$. If two activities can follow each other directly in any order, then all possible interleavings are present ² and therefore they are likely to be in parallel. Relation $\#_W$ gives pairs of transitions that never follow each other directly. This means that there are no direct dependency relations and parallelism is unlikely. In a formal mining approach (i.e. the α algorithm [3]) these three basic relations (i.e., $A \rightarrow_W B$, $A \#_W B$, or $A \parallel_W B$) are directly used for the construction of a Petri net. An advantage of the formal approach is that we can characterize the class of nets that can be mined correctly. It turns out that assuming a weak notion of completeness (i.e., if one activity can be followed by another this should happen at least once in the log), any so-called SWF-net without short loops and implicit places can be mined correctly. SWF-nets are Petri nets with a single source and sink place satisfying some additional syntactical requirements such as the free-choice property. In this paper, we will not elaborate on formal characterizations of the class of processes that can be successfully mined. For the details we refer to [3].

The formal approach presupposes perfect information: (i) the log must be complete (i.e., if an activity can follow another activity directly, the log should contain an example of this behavior) and (ii) there is no noise in the log (i.e.,

² If, for instance 10 activities are in parallel this can be a practical problem (10! possible patrons).

everything that is registered in the log is correct). Furthermore, the α -algorithm does not consider the frequency of traces in the log. However, in practical situations logs are rarely complete and/or noise free. Especially the differentiation between errors, low frequent activities, low frequent activity sequences, and exceptions is problematic. Therefore, in practice, it becomes more difficult to decide if between two activities (say A and B), one of the three derived relations (i.e., $A \rightarrow_W B$, $A \#_W B$, or $A \parallel_W B$) holds. For instance, the dependency relation as used in the α -algorithm ($A \rightarrow_W B$) only holds if and only if in the log there is a trace in which A is directly followed by B (i.e., the relation $A >_W B$ holds) and there is no trace in which B is directly followed by A (i.e., not $B >_W A$). However, in a noisy situation one erroneous example can completely mess up the derivation of a right conclusion. Even if we have thousands of log traces in which A is directly followed by B, then one $B >_W A$ example based on an incorrect registration, will prevent a correct conclusion. As noted before, frequency information isn't used in the formal approach. For this reason in the HeuristicsMiner we use techniques which are less sensitive to noise and the incompleteness of logs. The main idea is to take the frequency of the following relations into account while inferring the derived ones (i.e., $A \rightarrow_W B$, $A \#_W B$, or $A \parallel_W B$)

2.1 Step 1: mining of the dependency graph

The starting point of the HeuristicsMiner is the construction of a so called *dependency graph*. A frequency based metric is used to indicate how certain we are that there is truly a dependency relation between two events A and B (notation $A \Rightarrow_W B$). The calculated \Rightarrow_W values between the events of an event log are used in a heuristic search for the correct dependency relations.

Let W be an event log over T , and $a, b \in T$. Then $|a >_W b|$ is the number of times $a >_W b$ occurs in W , and

$$a \Rightarrow_W b = \left(\frac{|a >_W b| - |b >_W a|}{|a >_W b| + |b >_W a| + 1} \right) \quad (1)$$

First, remark that the value of $a \Rightarrow_W b$ is always between -1 and 1. Some simple examples demonstrate the rationale behind this definition. If we use this definition in the situation that, in 5 traces, activity A is directly followed by activity B but the other way around never occurs, the value of $A \Rightarrow_W B = 5/6 = 0.833$ indicating that we are not completely sure of the dependency relation (only 5 observations possibly caused by noise). However if there are 50 traces in which A is directly followed by B but the other way around never occurs, the value of $A \Rightarrow_W B = 50/51 = 0.980$ indicates that we are pretty sure of the dependency relation. If there are 50 traces in which activity A is directly followed by B and noise caused B to follow A once, the value of $A \Rightarrow_W B$ is $49/52 = 0.94$ indicating that we are pretty sure of a dependency relation.

A high $A \Rightarrow_W B$ value strongly suggests that there is a dependency relation between activity A and B. But what is a high value, what is a good threshold to take the decision that B truly depends on A (i.e. $A \rightarrow_W B$ holds)? The

threshold appears sensitive for the amount of noise, the degree of concurrency in the underlying process, and the frequency of the involved activities.

However, for many dependency relations it seems unnecessary to use always a threshold value. After all, we know that each non-initial activity must have at least one other activity that is its cause, and each non-final activity must have at least one dependent activity. Using this information in the so called *all-activities-connected heuristic*, we can take *the best* candidate (with the highest $A \Rightarrow_W B$ score). This simple heuristic helps us enormously in finding reliable causality relations even if the event log contains noise. As an example we have applied the heuristic to an event log from the Petri net of Figure 1 but with noise in it. Thirty event traces are used (nine for each of the three possible traces and three incorrect traces: ABCED, AECBD, AD) resulting in the event log $W = [ABCD^9, ACBD \cdot AED^9, ABCED, AECBD, AD]$. We first calculate the \Rightarrow -values for all possible activity combinations. The result is displayed in the matrix below.

\Rightarrow_W	A	B	C	D	E
A	0.0	0.909	0.900	0.500	0.909
B	0.0	0.0	0.0	0.909	0.0
C	0.0	0.0	0.0	0.900	0.0
D	-0.500	-0.909	-0.909	0.0	-0.909
E	0.0	0.0	0.0	0.909	0.0

We now apply the all-activities-connected heuristic on this matrix. We can recognize the initial activity A, it is the activity without a positive value in the A-column. For the dependent activity of A we search for the highest value in row A of the matrix. Both B and E are high (0.909). We arbitrarily choose B. If we use the matrix to search for the cause for B (the highest value of the B column) we will again find A as the cause for B. D is the depending activity of B (D is the highest value of the B row). The result of applying the same procedure on activity B, C, and E is presented in Figure 2; remark that only the causal relations are depicted in a so called *dependency graph*. The numbers in the activity boxes indicate the frequency of the activity, the numbers on the arcs indicate the reliability of each causal relation and the numbers on the nodes the frequencies. In spite of the noise, the causal relations are correctly mined.

In this example we know the process model that is used for generating the event log and we know the traces with noise (i.e. ABCED, AECBD, AD). However, in a practical situation we never know if for instance the trace AD is really noise or if it is a low frequent pattern. To handle this, three threshold parameters are available in the HeuristicsMiner: (i) the *Dependency threshold*, (ii) the *Positive observations threshold*, (iii) the *Relative to best threshold*. With these threshold we can indicate that we will also accept dependency relations between activities that have (i) a dependency measure above the value of the Dependency threshold, and (ii) have a frequency higher than the value of the Positive observations threshold, and (iii) have a dependency measure for which the difference with the "best" dependency measure is lower than the value of Relative

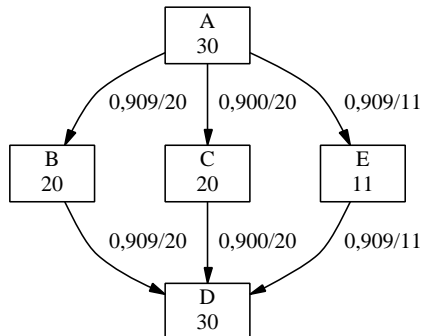

Fig. 2. A dependency graph resulting from applying the heuristic approach to a noisy log from the Petri-net of Figure 1.

to best threshold. In our example the following parameter setting will result in a dependency graph in which also the low frequent behavior AD is modelled: Dependency threshold = 0.45, Positive observations threshold = 1, Relative to best threshold = 0.4 In practical situations (with event logs with thousands of traces, low frequent traces and some noise) these parameters are very useful to get insight in the main behavior and/or the details of processes.

However, the basic algorithm as presented above is far from complete. It can't handle *short loops*, the type of the dependency relations (AND/XOR-split/join) isn't represented in the dependency graph, there are problems with *non-observable activities*, and it can't handle *long distance dependencies*.

Short loops In a process, it may be possible to execute the same activity multiple times. If this happens, this typically refers to a loop in the corresponding model. Long distance loops (e.g. ...ABCABCABC...) are no problem for the HeuristicsMiner presented so far (the values of $A \Rightarrow_W B$, $B \Rightarrow_W C$, and $C \Rightarrow_W A$ are useful to indicate dependency relations). However, for length-one loops (i.e. traces like ACB, ACCB, ACCCB, ... are possible) and loops of length two (i.e. traces like ACDB, ACDCDB, ACDCDCDB, ... are possible) the value of $C \Rightarrow_W C$ and $C \Rightarrow_W D$ is always very low. However, it appears very simple to define the dependency measure for loops of length one and length two. Let W be an event log over T , and $a, b \in T$. Then $|a >_W a|$ is the number of times $a >_W a$ occurs in W , and $|a >>_W b|$ is the number of times $a >>_W b$ occurs in W .

$$a \Rightarrow_W a = \left(\frac{|a >_W a|}{|a >_W a| + 1} \right) \quad (2)$$

$$a \Rightarrow_2 W b = \left(\frac{|a >>_W b| + |b >>_W a|}{|a >>_W b| + |b >>_W a| + 1} \right) \quad (3)$$

During the construction of the dependency graph loops of length one are treated in the same way as other activities (they need an external cause and a dependent activity). Loops of length-two need a special treatment while applying the all-activities-connected heuristic. They form a pair and as a pair they need only one cause and one depending activity.³

2.2 AND/XOR-split/join and non-observable tasks

The process model for the event log $W = [ABCD, ABCD, ACBD, ACBD, AED]$ shown in Figure 1(a) is a Petri net. Activities are represented by transitions. After executing of the first task A, there is a choice between either executing B and C concurrently (i.e., in parallel or in any order) or just executing activity E. To execute B and C in parallel two non-observable activities (AND-split and AND-join) have been added. Mining of these non-observable activities is difficult, because they are not present in the event log. To avoid the explicit modelling of invisible activities, in the HeuristicsMiner we don't use Petri nets for the representation of process models, but so called *Causal Matrix*. The translation of a Petri net to a Causal Matrix is straightforward [8]. As an example we show the translation of the Petri net of Figure 1 to the Causal Matrix representation.

<i>ACTIVITY</i>	<i>INPUT</i>	<i>OUTPUT</i>
A	\emptyset	$(B \vee E) \wedge (C \vee E)$
B	A	D
C	A	D
D	$(B \vee E) \wedge (C \vee E)$	\emptyset
E	A	D

Table 2. The translation of the Petri net of Figure 1(a) to a Causal Matrix.

Each activity has an input and output expression. Because A is the start activity the input expression is empty and activity A is enabled. After the firing of A the output $(B \vee E) \wedge (C \vee E)$ is activated (i.e. $(B \vee E)$ is activated and $(C \vee E)$ is activated). We now look if activity B is enabled. Because the input expression of B is only A, we have to look if all B's are active in the output expression of A. This is the case. But because the \vee in $(B \vee E)$ is an exclusive or, the $(B \vee E)$ isn't longer activated but the $(C \vee E)$ expression still is. We

³ A length-one loop C in combination with a concurrent process A can easily produce patterns like CAC. To prevent the HeuristicsMiner for this trap a length-two dependency relation ($A \Rightarrow_2 W C$) between A and C only holds if A and C are not length one loops. In short, we first calculate equation (2) and then (3). This way we capture all tasks in a length-one loop construct before searching for length-two loops.

now look if activity E is enabled. Because the input expression of E is only A, we have to look if all E's are active in the output expression of A. This is the not case because $(B \vee E)$ is no more activated. However, activity B is still enabled (all relevant expressions are still activated). This is exactly the behavior we like to model. For more details about the semantics of Causal Matrices we refer to [7]. The same paper gives detailed information about the translation of a Causal Matrix to a Petri net. This translation is a little more complex because appropriate hidden activities must be introduced. We will now concentrate on the heuristics for mining the correct logical expressions.

The underlying idea is relative simple. Let we start with a simple example. The dependency graph of (Figure 2) already gives the information that activities B,C and E are in the output expression of activity A (as sown in Table 2). If two activities (e.g. B and E) are in the AND-relation, the pattern ...BE... can appear in the event log. If two activities (e.g. B and C) are in the XOR relation the pattern ...BC... isn't possible. The following measurement is defined to express the above formulated idea. Let W be an event log over T , $a, b, c \in T$, and b and c are in depending relation with a. Then

$$a \Rightarrow_W b \wedge c = \left(\frac{|b >_W c| + |c >_W b|}{|a >_W b| + |a >_W c| + 1} \right) \quad (4)$$

The $|a >_W b| + |a >_W c|$ indicates the number of positive observations and $|b >_W c| + |c >_W b|$ indicates the number of times b and c appear directly after each other. Given the event log with noise (i.e. $W = [ABCD^9, ACBD^9, AED^9, ABCED, AECBD, AED]$) the value of $A \Rightarrow_W B \wedge C = (10+10/10+9+1) = 1.0$ indicating that B and C are in a AND-relation. The value of $A \Rightarrow_W B \wedge E = (0/10+11+1) = 0.00$ and the value of $A \Rightarrow_W C \wedge E = (1+1/9+11+1) = 0.09$ indicating that B,E and C,E are both in a XOR-relation. During all our experiments a default value of 0.1 for the $a \Rightarrow_W b \wedge c$ -parameter is used. Given the input and output set of each activity in the Dependency graph in combination with the $a \Rightarrow_W b \wedge c$ measure the construction of the AND/XOR-split/joins is straight forward. As an illustration we follow the construction of the output-expression of activity A (e.g. A_{output}). Because there are dependency relations from A to B,C, and E the basic material is the set $\{B, C, E\}$. We will start with the first element in BCE (e.g. $A_{output} = ((B))$). The next element is C. The value of $A \Rightarrow_W B \wedge C = 1.00$ (e.g. B and C are in a AND-relation, and the new value of $A_{output} = ((B) \wedge (C))$). In the next step we use the values of $A \Rightarrow_W B \wedge E = 0.00$ and $A \Rightarrow_W C \wedge E = 0.09$. If both values were above the \wedge -threshold value of 0.1 then the new A_{output} -expression would be $((B) \wedge (C) \wedge (E))$. But both calculated values are below the \wedge -threshold resulting in $A_{output} = ((B \vee E) \wedge (C \vee E))$.⁴ The result of applying the HeuristicsMiner as defined so far on the example event log with noise will result in the HeuristicNet as presented in Table 2.

⁴ If we start the procedure above with activity E the result would be $((E \vee B) \wedge C)$. Therefore an extra loop is performed in which we check for all of the \vee -groups if this group can be extended with any of the available activities.

2.3 Step 3: Mining long distance dependencies

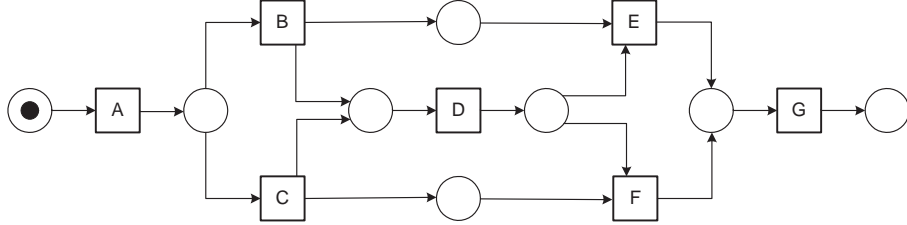

Fig. 3. A process model with a non-free-choice construct.

In some process models the choice between two activities isn't determined inside some node in the process model but may depend on choices made in other parts of the process model. Figure 3 shows a long distance dependency construct. After executing activity D there is a choice between activity E and activity F. However, the choice between E and F is “controlled” by the earlier choice between B and C. Clearly, such non-local behavior is difficult to mine for mining approaches primarily based on binary information ($a >_W b$). Only a few process mining algorithms [4, 11] are able to mine them successfully. Mining an event log generated by the process model of Figure 3 with the HeuristicsMiner as presented so far, will result in a dependency graph without the B to E and C to F connection. However, the $a \gg \gg_W b$ -relation as given in Section 2 will strongly indicate that B is always followed by E and C by F. (e.g. if $|B|$ is the frequency of activity B, then $B \Rightarrow_W^l E = |B \gg \gg_W E| / |B| + 1$ value close to 1.0). But many high \Rightarrow_W^l -values are already sound with process model. For instance, if we look in the process model of Figure 3 then the value of $A \Rightarrow_W^l D$ will be close to 1.0 but no extra dependency relation is necessary. We can check this by looking at the process model mined so far and test out if it is possible to go from A to the end activity (G) without visiting activity D. Only if this is possible the process model is updated with the extra dependency relation from A to D and the logical input and output expressions of the Causal Matrix are updated in line with this new connection. The pseudo code for the “long-distance-dependency-heuristic” is given in the Appendix (Table 4).

3 Experimental results

In this experimental section we will introduce our benchmark material, some relevant measurements for this material, measurements by which the performance of process mining algorithms can be assessed, and finally the performance measurements of the HeuristicsMiner for the benchmark material. But, as an intermezzo we will first illustrate the HeuristicsMiner on low frequent behavior and noise.

3.1 An Illustration

As a first illustration the process model in Figure 4 is used for generating event logs. All examples in an event log are, in principle, positive examples; negative examples are not available or it isn't clear which traces are wrong. This starting-point is an extra handicap during mining; specially the combination of low frequent patterns and noise is problematic. The loop from activity J to C and the direct connection from activity D to K are used to exemplify the behavior of the HeuristicsMiner algorithm in case of exceptions (low frequent behavior) and noise. One noise free event log with 1000 random traces is generated. Remark that activities D1, D2 and D3 are not present in the event log (i.e. they are invisible tasks). One other event log with 1000 traces is generated where 5% of traces contains noise. To incorporate noise in our event logs we define five different types of noise generating operations: (i) delete the head of a trace, (ii) delete the tail of a trace, (iii) delete a part of the body, (iv) remove one event, and finally (v) interchange two random chosen events. During the deletion-operations at least one event, and no more than one third of the trace is deleted. To incorporate 5% noise the traces of a noise free event log are randomly selected and then one of the five above described noise generating operations is applied (each noise generation operation with an equal probability of 1/5).

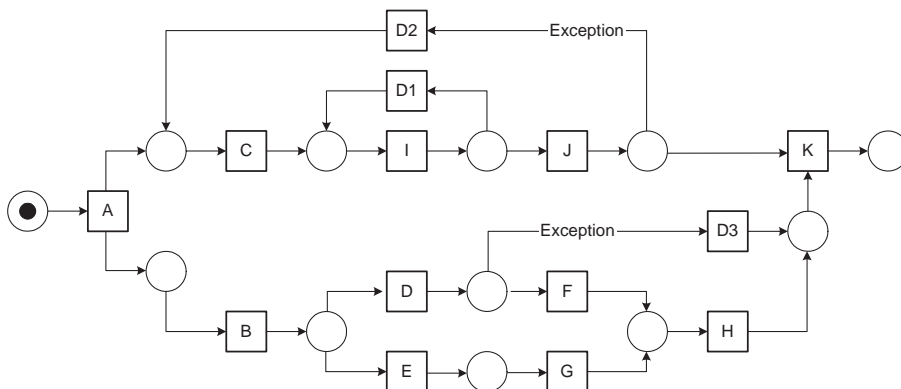

Fig. 4. The process model used for generating event logs (with and without noise).

Using the default parameter setting of the HeuristicsMiner (relative to best threshold=0.05, positive observations=3, dependency threshold=0.9 and AND-threshold=0.1) mining of the noise free example results in the dependency graph of Figure 5. To save space, the logical behavior of the splits and joins is depicted in the dependency graph (using the $\&$ and \vee symbols). Remark that only the main behavior (not the low frequent behavior) is reflected in the graph.

If we change the parameter setting a bit so that less reliable dependency measures are also accepted, for instance, using relative to best threshold = 0.05,

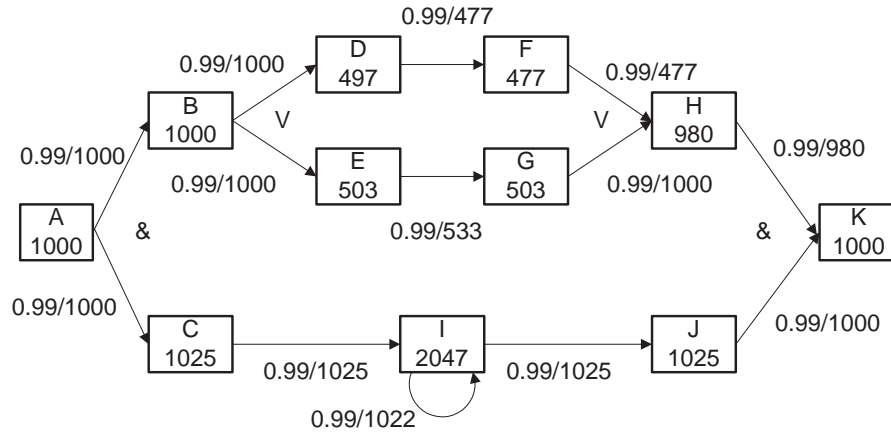

Fig. 5. The result of HeuristicsMiner with default parameter setting and without noise (relative to best threshold=0.05, positive observations=3, dependency threshold=0.9 and AND-threshold=0.1). Note that the two low frequent dependency relations (from D to K and from J to C) are not in the model.

positive observations = 3, dependency threshold=0.9 and AND-threshold = 0.1, the model depicted in Figure 6 is mined. Note that this model also contains the low frequent dependency relations that are not in the model in Figure 5.

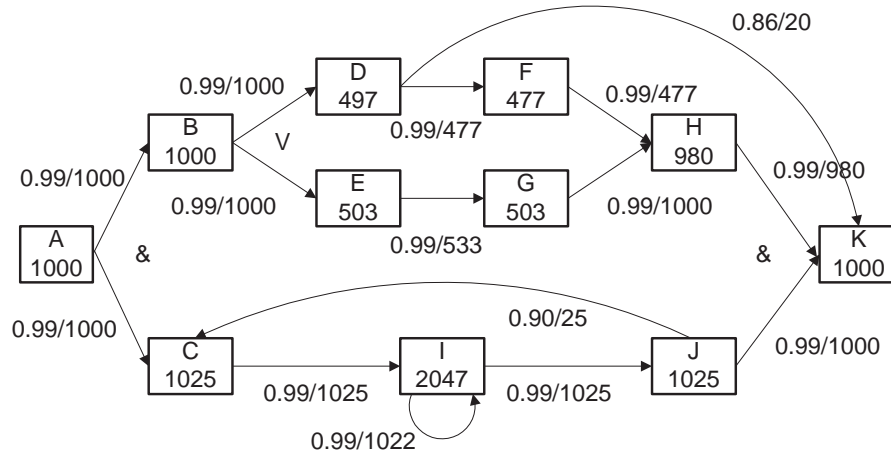

Fig. 6. The result of HeuristicsMiner with updated parameter setting and without noise (relative to best threshold = 0.20, dependency threshold = 0.85, without noise). Note that low-frequent dependency relations (from D to K and from J to C) are caught with this setting, but were not when using the default parameters (i.e. Figure 5).

The two low frequent dependency relations are now correctly mined. Looking at the numbers in 6 shows that the first relation from J to C is only used 25 times (i.e. that the pattern J...C appears 25 times in the event log). Because there is concurrency, the situation in which J is directly followed by C only can be lower. The frequency for the D...K pattern is even lower, 20 times. If we use the default parameter setting to mine the event log with 5% noise the mined process model is exactly the same model as the model in Figure 5 (only the the dependency values between activities are in general a little bit lower). If we mine the event log with noise in combination with a parameter setting such that also less reliable dependency measures are accepted (i.e. the setting used above: relative to best threshold=0.20, dependency threshold=0.8) the two low frequent dependency relations are correctly mined. However, also an extra dependency relation (value 0.8, frequency 7) between A and I is found. Because we know the correct model, it is simple to choose the parameter setting in such a way that exactly the correct model is mined (e.g. relative to best threshold=0.20, dependency threshold=0.85). However, in a realistic setting one doesn't know if registered behavior in the event log is low frequent behavior or noise. The parameters of the HeuristicsMiner can be use to catch only high frequent behavior or also low frequent behavior. But mining for also the low frequent behavior has always the risk to catch also noise.

Some remarks about the parameters of the HeuristicsMiner seems relevant. First, during the construction of the basic process model the *all-activities-connected heuristic* is used. During applying this heuristic the values of the different parameters are ignored; simply one ingoing and outgoing connection with the highest dependency value is accepted. For instance, in the B1 Petri net (Figure 7 of the Appendix) all the connections of the net are accepted on the basis of the all-activities-connected heuristic. If we **know** that we have a noise free log, we can simply use an extraordinary intolerant parameter setting (e.g. positive observations threshold = 1000, dependency threshold = 1.0, and relative to best threshold = 0.00); with this setting, the constructed B1-model will always have exactly the right connections⁵. The main function of the parameters is the extension of the model on the basis of low frequent behavior. Extra connections are only accepted if (i) the positive observations are above the threshold **and** if (ii) the dependency value is above the threshold **and** if (iii) the difference between the new dependency value and the first accepted one is less than the relative to best threshold. Finally, there is a strong correlation between the positive observation threshold and the dependency threshold. For instance, choosing a dependency threshold of 0.9 means that we need more than 10 positive observation of A directly followed B to accept an dependency between A and B. After all, if $|A >_W B| = 10$ and there is no noise, then $A \Rightarrow_W B = |A >_W B| - |B >_W A| / |A >_W B| + |B >_W A| + 1 = 10/10+1 = 0.909$. That means that our default positive observation threshold of 3 is a relative low. Changing only the value of

⁵ This does not hold for the other models in the appendix B2, B3, and B4; if we only use the all-activities-connected heuristic, some connections are missing.

the positive observation threshold to a higher value but equal or lower than 10 will never result in the mining of the (extra) connections.

In above experimental setting - where we know the process model used for generating event logs - we can easily check to what degree mined models are comparable with the original models. However, in a practical setting it is only possible to search for an optimal process model in the sense that is in accordance with the information in the *event log*. Testing if all traces can be parsed correctly by the mined process model is one possibility to check the quality of a model. The ParsingMeasure (PM) is defined as the number of correct parsed traces divided by the number of traces in the event log. The PM-values for the four mined models discussed above (i.e. (i) default parameters, without noise; (ii) updated parameters without noise; (iii) default parameters, with noise; (iv) updated parameters with noise) are given in the PM-column of Table 3. The values (0.96, 1.00, 0.91 and 0.95) seems in accordance with the discussed mining results. For instance, the PM-value (0.96) of mining with default parameters and a noise free event log does not model the low frequent behavior in 45 traces (from D to K and from J to C), resulting in a PM of 0.96.

Experiment	PM	CPM
(i) no noise, default parameters	0.96	0.997
(ii) no noise, updated parameters	1.00	1.000
(iii) 5% noise, default parameters	0.91	0.990
(iv) 5% noise, updated parameters	0.95	0.995

Table 3. Mining performance results for the four experiments in the illustrative example (e.i. (i) default parameters, without noise; (ii) updated parameters without noise; (iii) default parameters, with noise; (iv) updated parameters with noise). PM is the naive Parsing Measure; after an error the parsing stops. CPM is the Continuous Parsing Measure; after an error the error is recorded and the parsing goes on.

However, this PM fitness measure seems to naive. First of all, if for one process model the parsing get stuck at many places of a trace and in an other process model there is only one error at the end of the trace we prefer the second model. The ContinuesParsingMeasure (CPM) is a quality measure that takes this element into account. During the calculation of the CPM we don't stop the parsing of a trace if an error occurs. Instead the error is recorded and the parsing goes on. That means that this quality measure is based on the number of successfully *parsed events* instead of the number of *parsed traces* (1000). Moreover, we like proper completion of the parsing process (i.e. if the end event is parsed there are no hanging active logical expressions in the process model). Both, missing active expressions during parsing and hanging activated expressions after parsing have a negative influence on the quality of the process model. The following measurement is defined to express the above formulated

idee. Let W be an event log with e events, m is the total number of missing activated input expressions, and r the number of remaining activated output expressions. Then the CPM is

$$CPM = \frac{1}{2} \frac{(e - m)}{e} + \frac{1}{2} \frac{(e - r)}{e} \quad (5)$$

The CPM-values for the four mined models discussed above are given in the CPM-column of Table 3. All CPM-values are close to one indicating that in all the process models most activities are correctly modelled (i.e. dependencies and logical expressions are correct).

Up to here an illustration of the process mining performance of the Heuristic-Miner on an example. In contrast with the machine learning research domain, general used process mining benchmarking material is missing. For that reason we started a collection of four sets of event logs for benchmarking process discovery algorithms. In the next section (section 3.2) we first describe the four benchmark sets and their characteristics. In section 3.3 we explain our mining performance measurements. Finally, the performance results for the Heuristic-Miner are given (Section 3.4).

3.2 Benchmark material

Starting point for the benchmark material are the Petri nets as given in the Appendix. Petri net B1 (cf. Figure 7) contains 16 activities and AND/XOR-split/joins, but no loops. Petri net B2 (cf. Figure 8) is an extension of net B1 with different types of loops (i.e. a long loop, a length two loop and recursion). Petri net B3 (Figure 9) is an extension of B2 with extra parallel behavior in eight extra activities. In the event logs of Petri net B2 and B3 there are non-observable (or dummy) tasks (DUM1, DUM2, and DUM3). They are registered in the event logs of the B2 (Dum1) and B3 (DUM1, DUM2, and DUM3) material. In the B4 experiments the non-observable (or dummy) tasks are not registered in the log. Mining of the event logs without information about non-observable activities is more difficult than mining with this information. Besides the differences in the Petri net models the following variations are used.

The amount of imbalance in execution priorities

In the Petri net used for generating the benchmark material each activity has an execution priority between 0 and 2. If during the generation of an event-trace more than one activity is enabled, the priority value is used to calculate the chance that a specific activity is chosen. Suppose that in the Petri net B1 (cf. Figure 7), the priority of activity B is 0.5 and the priority of activity C is 1.5. Then, after executing activity A (i.e. an AND-split) the chance that the next activity is B is 25% and the chance that the next activity is C is 75% (i.e. there is a higher chance for the A,C,B,... pattern as for the A,B,C,...). Suppose that in the same Petri net B1, the priority of activity F is 0.5 and the priority of activity G is 1.5. Then, after executing activity C (i.e. an XOR-split) the chance for the F,I,M track is 25% and the chance for the G,J -track is 75%.

Our hypothesis is that extreme imbalance will negatively affect the rediscovery process; low frequent, but possible behaviors is not or hardly registered in the log.

Completeness of the event log

The quality of mining results are strongly affected by the completeness of the event log. Only if a representative and a sufficient large subset of possible behaviors is registered in the log, successful mining is possible. It is clear that an extensive log with extreme imbalances can be incomplete. In the formal approach in [3], we characterize the class of nets that can be mined correctly. It turns out that assuming a weak notion of completeness (i.e., if one activity can be followed by another this should happen at least once in the log), any so-called SWF-net without short loops and implicit places can be mined correctly. Notwithstanding in the HeuristicsMiner a stronger completeness notation is needed ⁶ we will use this weak completeness notation to indicate the completeness of an event log. For instance, in the Petri net B2 181 directly following relations are possible (183 after adding an artificial begin- and end-task). It may be that in a small or very imbalanced event log only 172 different following relations are registered in the event log. It is clear that both the size of an event log and the imbalance can influence the completeness of the log.

Noise

As stated before, we distinguish five different types noise generating operations: (i) delete the head of a event sequence, (ii) delete the tail of a sequence, (iii) delete a part of the body (iv) remove one randomly chosen event, and (v) interchange two randomly chosen events. For each type of Petri net, we distinguish six different amounts of imbalance: 01, 02, 05, 10, 20, 50. In the 01 situation the priority value of an activity has a value between $0.01=0+0.01$ and $1.99=2-0.01$ (i.e. a very high imbalance). In the 50 situation the priority value of an activitie has a value between 0.50 and 1.50 (i.e. a low imbalance). For each imbalance value 10 different imbalance distributions are randomly generated and for each imbalanced Petri net 10 event logs with 1000 traces are generated. For each Petri net this will result in 600 different noise free event logs. We will use the notation B1P05_09_01_X00 to indicate an event log based on Petri-net B1 with an imbalance of 0.05 to 1.95 (P05) and random event log number 9 (09). The X00 indicates that there is no noise in the event log. Starting with this noise free material we generated event logs with a mix ⁷ of the five different noise types (each noise type has an equal chance to appear) and with six different

⁶ A stronger completeness notation is needed because we use thresholds. For instance by using a positive observation threshold of 3 at least three observations are needed. A second reason is the use of measurements not only based on the directly following relation (i.e. $a \gg_w b$ and $a \gg\gg_w b$ Definition 2).

⁷ Event logs with only a specific noise type (i.e H(head), T(tail), W(waist), O(one), I(interchange), M(mix)) are available. Starting with the noise free log B1P05_09_01_X00 we will use the event log name B1P0509I05 to indicate 5% noise interchange noise (I05). In this paper only the experimental results for the mixed noise are reported.

noise-levels (1%, 2%, 5%, 10%, 20% and 50% noise). For each noise free event log this results in 6 new event logs with noise. Starting with the noise free log B1P0509X00 we will use the event log name B1P05_09_01_M05 to indicate 5% noise mixed noise (M05). The event log B1 is the event log with 1000 traces of the original Petri net with the same structure but without imbalance.

Before we present the mining results of the HeuristicsMiner on the described benchmark material we discuss the different measurements we have used to get an impression of the process mining performance of one mining experiment.

3.3 Event log and performance measurements

In a typical process mining experiment without noise an event log (e.g. B1P05_09_01_X00) is used as mining material. After mining the discovered model the same event log (i.e. B1P05_09_01_X00) is first parsed by the mined model and then the B1 event log (i.e. a complete event log from the original, balanced Petri net). Table 3.3 shows the different measurements as registered for one mining experiment.

We can distinguish four groups of properties/measurements: (i) properties of the event log, (ii) properties of the mined model, (iii) results of parsing the mined event log, (iv) results of parsing an balanced-version of the mined event log. Both, $a > b(130)$ and $a > b \geq b \geq$ are event log measurements that indicate the weak completeness of the log. $a > b(130) = 124$ indicates that 124 from the possible 130 direct following relations (i.e. $a >_W b$) are really one or more times registered in the event log and $a > b \geq 3 = 116$ indicates that 116 from them appears more than three times. It is very well possible to calculate more and other event log properties like the standard deviation from the different activity frequency. A closer look at the mining results shows that the mined model has one extra connection (i.e. $\#conn(20) = 21$ and not 20) from activity O to B. This seems strange, but a closer inspection of the event log B1P05_09_01_X00 displays 601 registrations of event O directly followed by B and 18 registrations the other way around. Strong imbalance in the original Petri net B1P0_09 seems the cause for this unexpected behavior: the chance of activity B appears very low 0.11 on a scale of 0.05 to 1.95. The time the HeuristicMiner require for the construction of the process model is 7 mili seconds (mining time = 0:07) If we use the mined model to parse the mined event log (i.e. (iii) results of parsing the mined event log), the extra connection creates errors: only 399 out of 1000 traces ($\#correctT1 = 399$) are completely correct parsed (i.e. no missing or left activities). The performance on an event level appears better: 14764 out of 15365 events are correctly parsed. There are only missing activations ($\#missingA1 = 601$), no left activations ($\#leftA1 = 0$). The resulting CPM-fitness value for mined event log is 0.980 (fitness1 = 0.980). The lowest part of Table 4 displays the parsing results for the traces in the event log B1 (i.e. a balanced version of Petri net B1). It is surprising that the results on this event log are slightly better: 983 correct parsed traces ($\#correctT1= 399$), only 62 missing activities ($\#missingA2 = 62$), and a CPM-fitness very close to one (fitness2 = 0.998).

Item	Example	Clarification
Event log properties		
event log	B1P05_09_01_X00	mined event log,
$(a > b) \geq 3$	116	imbalance P05 (between 0.05 and 1.95) no noise 116 from the 124 direct following relations (i.e. $a >_w b$) appear three times or more
$(a > b) (130)$	124	124 from the 130 possible direct following relations (i.e. $a >_w b$) are really in the event log
Results of mining event log B1P05_09_01_X00		
#conn (20)	21	the number of mined connections (20 for the original B1 model)
correct	0	1 model is correct, 0 the model has errors
Mining time	0.08 sec	time needed to construct the process model
Results of parsing log B1P05_09_01_X00 with the mined model		
#correctE1	14764	number of correct parsed events
#E1	15365	number of events
#correctT1	399	number of correct parsed traces
#T1	1000	number of traces (1000 for all experiments)
#missingA1	601	number of missing activations
#leftA1	0	left activations
fitness1	0.980	fitness of the mined event log
parsing time	0.08 sec	time needed to parse the event log
Results of parsing B1 with the mined model		
#correctE2	15451	number of correct parsed events of B1
#E2	15513	number of events in log B1
#correctT2	938	number of correct parsed traces
#T2	1000	number of traces (1000 for all experiments)
#missingA2	62	number of missing activations
#leftA2	0	left activations
fitness2	0.998	fitness of the B1 event log
parsing time	0.08	time needed to parse the extra event log

Table 4. Example of the registered data during mining of one noise free event log.

3.4 HeuristicsMiner benchmark results

Below we present the HeuristicsMiner process mining benchmark results on the material as described in subsection 3.2. We first focus on the influence of the amount of incompleteness in the event logs. After that the focus is on the influence of the amount of noise.

Tables 5, 6, 7, and 8 display the mining performance results for 2400 event logs; 600 for every Petri net (B1, B2, B3 and B4) and with different imbalances (P01, P02, P05, P10, P20, P50), but all noise free. The imbalance strongly influence the completeness of the event logs. To save space only the most informative measurements of the measurements discussed above are displayed in the tables. For instance, there is a strong relation between the number of correct parsed event, missing and left activities and the fitness measurement. For this reason only the fitness is reported. Because the time needed for the mining of the event logs and for parsing an event log is about the same (≈ 0.10 seconds) for all logs in the same benchmark set, this information is also not presented in the tables.

However, a short general remark about the memory and time complexity of the HeuristicsMiner algorithm seems relevant. Given an event log W , with k different events and t traces, the first step in the mining algorithm is the calculation of the values of basic relations (i.e. $|a >_W b|$, $|a \gg_W b|$, and $|a \gg\gg_W b|$). The traces can be loaded trace by trace, and the information is stored in three $k \times k$ arrays. The time complexity of this part of the algorithm is linear to the number of traces and k^2 to the number of different activities. After the calculation of the values of the basic relations, only these values are used for the construction of the process model. This time complexity of this part of the algorithm is again k^2 . The HeuristicsMiner is implemented Java in the ProM framework [5] and in a stand alone version in Delphi. Using the Delphi implementation on a standard notebook (Dell Latitude D800) the mining of an event log from B1, B2, B3 en B4 benchmark sets takes in average respectively 0.08, 0.14, 0.16, and 0.12 seconds. Parsing of an event log takes in average respectively 0.08, 0.12, 0.12, and 0.12 seconds.

B1 material: Average results (6 x 10 x 10 experiments)						
measure	P01	P02	P05	P10	P20	P50
$a > b \geq 3$	119.3	117.0	121.2	124.3	126.1	128.9
$a > b$ (max 130)	125.7	125.4	127.1	128.2	128.8	129.8
Avg. connections (20)	20.5	20.8	20.4	20	20	20
#correct models	55	60	62	100	100	100
Avg. fitness	.986	.984	.992	1.0	1.0	1.0
Avg. fitness B1	.991	.990	.996	1.0	1.0	1.0
Avg. missing	273	285	119	0	0	0
Avg. left	10	29	0	0	0	0

Table 5. Process mining performance results for the 6 x 10 x 10 B1 experiments (imbalance and incompleteness).

Table 5 shows the performance results for the 6 x 100 B1 experiments. It is clear that the imbalance influence the completeness of the event log (line $a > b$ in the table). A weak imbalance (P50) results in practically complete event logs, a strong imbalance in a more incomplete event log (i.e. in average 125.7 different direct succeed pairs, and 119.3 pairs with a frequency of 3 or higher). It is clear that there is a high correlation between the completeness of the event log and the quality of the mined process models. All P50, P20, and P10 models are always correctly mined. For the P01, P02, and P03 models half of the models are exactly the original model. It seems that the mining error in the other models is one extra connection (average connections 20.5, 20.8, and 20.4) resulting in some missing activations (average missing 273, 285, 119) and only a few left activations (average left 10, 29, and 0). The results for the B2, B3 and B4 models (Table 6, 7, and 8) are more or less analog in the sense that a weaker imbalance results in more complete event logs and better mining results. More specific observations are discussed below.

B2 material: Average results (6 x 10 x 10 experiments)						
measure	P01	P02	P05	P10	P20	P50
$a > b \geq 3$	162.7	160.2	173.5	166.6	173.1	177.8
$a > b$ (max 183)	173.1	172.4	178.9	176.5	178.9	181.9
Avg. connections (27)	27.1	26.9	27.1	26.9	27	27
#correct models	43	34	79	84	96	100
Avg. fitness1	.990	.981	.993	.997	1.0	1.0
Avg. fitnessB2	.985	.980	.994	.997	1.0	1.0
Avg. missing	731	1012	262	157	19	0
Avg. left	94	94	61	28	2	0

Table 6. Process mining performance results for the 6 x 10 x 10 B2 experiments (imbalance and incompleteness).

It is clear that the mining results for the B2 experiments (Table 6) are slightly weaker than the B1 results (Table 5). However, in many mining experiments the exact original model was mined. All mined models can practically mine all events in the traces resulting in a B1 fitness close to one (0.985, 0.980, 0.994, 0.997, 1.0, and 1.0). Remark that the average fitness of the P01 models on the mining material (Avg. fitness1 = 0.990) is higher than the fitness on the test material (Avg. fitnessB1 = 0.985). It seems that there is a light tendency to (over)fit the learning material. Again, there are some missing activations and only a few left one.

Model B3 is an extension of B2. However, the mining performance results for the B3 experiments (Table 7) are comparable with B2 results (Table 6). All mined models can practically mine all events in the event-traces resulting in a B1 fitness close to one (0.980, 0.976, 0.976, 0.992, 0.998, and 1.0). All experiments but P50, seem to have a slight tendency to (over)fit the learning material: the

B3 material: Average results (6 x 10 x 10 experiments)						
measure	P01	P02	P05	P10	P20	P50
$a > b \geq 3$	273.2	247.7	273.6	289.2	304.9	316.0
$a > b$ (max 339)	303.0	286.6	308.3	313.6	321.0	327.9
Avg. connections	37.3	37.1	37.3	36.8	37.0	37.0
#correct models	31	24	31	57	91	100
Avg. fitness1	.984	.978	.979	.993	.999	1.0
Avg. fitnessB3	.980	.976	.976	.992	.998	1.0
Avg. missing	954	1212	1280	86	86	0
Avg. left	179	167	107	10	10	0

Table 7. Process mining performance results for the 6 x 10 x 10 B3 experiments (imbalance and incompleteness).

average fitness of the mined models on the mining material (Avg. fitness1) is higher than the fitness on the test material (fitnessB1). Again, there are some missing activations and only a few left one. Apart from that it is surprising that average completeness of the P02 material is relatively low ($a > b = 286.6$). Also the average fitness1 and fitnessB3 of the mined models is low (0.978 and 0.976) indicating that there is a high correlation between the completeness of an event log on the mining results.

B4 material: Average results (6 x 100 experiments)						
measure	P01	P02	P05	P10	P20	P50
$a > b \geq 3$	232.8	214.3	233.0	246.3	257.4	265.9
$a > b$ (max 274)	253.7	243.7	258.4	262.8	267.5	271.2
Avg. connections (34)	34.1	34.0	34.1	33.8	34.0	34.0
#correct models	6	10	20	39	62	94
Avg. fitness1	0.952	0.950	0.968	0.980	0.987	0.998
Avg. fitnessB4	0.949	0.952	0.961	0.980	0.988	0.999
Avg. missing	2284	2214	1851	938	539	60
Avg. left	365	306	196	124	60	9

Table 8. Process mining performance results for the 6 x 100 B4 experiments (imbalance and incompleteness).

In the event log of the B4 experiments (Table 8) the hidden activities (DUM1, DUM2, and DUM3) are removed out of the B3 event logs. Mining the B4 material seems more difficult than mining of the B3 material (Table 7). This is in line with fitness results of the B3 and B4 experiments (0.980 vs. 0.949, 0.976 vs. 0.952, 0.976 vs. 0.961, 0.992 vs. 0.980, 0.998 vs. 0.988, and 1.0 vs. 0.999). However, specially for the experiments with only a weak imbalance the differences are minimal. Because the B4 material is the B3 material with the hidden activities

removed, the average completeness of the P02 material is relatively low ($a > b = 243.7$). However, the drop in the average fitness1 and fitnessB4 of the P02 experiments isn't so distinctly as in the B3 experiments. So far the mining results of event logs without noise.

Tables 9, 10, 11, and 13 displays the mining performance results for $4 \times 3600 = 14400$ event logs; $6 \times 6 \times 10 \times 10 = 3600$ for every Petri net (B1, B2, B3 and B4), 10×10 event logs with different imbalances (P01, P02, P05, P10, P20, P50), and with different noise levels (1%, 2%, 5%, 10%, 20%, and 50% noise). The presence of noise is reflected in the average amount of available direct succeed relations (the $a > b$ -line in the tables). Remark that the number of different $a > b$ relations in a event log with noise can be higher than the maximum number of different $a > b$ patterns in a noise free event log. The general observation is that 1%, 2%, 5%, and 10% hardly influence the mining performance results (the average number of correct mined models, average fitness measurements, and the average missing and left activations). For instance, in the B1 experiments (Table 9) with a high imbalance (the P01 column) the sum of the correct mined models drops from 55 (no noise, Table 5) to respectively 55 (1% noise), 54 (2% noise), 55 (5% noise), 57 (10% noise), 48 (20% noise), and 36 (50% noise). The fitness for the B1 materials (fitness3) drops from 0.991 (no noise, Table 5) to respectively 0.991 (1% noise), 0.991 (2%), 0.990 (5%), 0.989 (10%), 0.986 (20%), and 0.974 (50% noise). The missing/left activations are respectively 273/10 (0% noise, Table 5), 277/10 (1%), 277/18 (2%), 291/18 (5%), 302/39 (10%), 330/99 (20%), and 751/53 (50% noise). In all four Tables (9, 10, 11, 13) the influence of 1% to 20% noise is slight; with 50% the decrease in mining performance is more distinctly, but the HeuristicsMiner is still able to construct a process model with a relatively high fitness on learning and test material.

4 Conclusion

In this paper, we first introduced the challenging problem of process mining. We distinguish three different perspectives: (1) the process perspective, (2) the organizational perspective and (3) the case perspective. We focused on the process perspective. Hereafter, we presented the details of the three steps of the HeuristicsMiner algorithm: Step (1) the construction of the dependency graph, Step (2) for each activity, the construction the input- and output expressions and Step (3) the search for long distance dependency relations. Simultaneously we introduced a new process modelling language (e.g. Causal Matrices) and we illustrate the advantages of Causal Matrices during the mining of hidden activities. In the experimental session we showed how the HeuristicsMiner can deal with noise and low frequent behavior. In practical situation (i.e. with event log with thousands of traces, low frequent behavior and some noise) the HeuristicsMiner can focus on all behavior in the event log, or only the main behavior.

In this paper we first introduced the challenging process mining domain. Hereafter, we presented the details of the three steps of the HeuristicsMiner algorithm: Step (1) the construction of the dependency graph, Step (2) for each

B1 material: Average results (6 x 6 x 10 x 10 experiments)						
Noise level 1%	P01	P02	P05	P10	P20	P50
Avg of $a > b \geq 3$	119.4	117.1	121.3	124.5	126.3	129.0
Avg of $a > b$ (max 130)	135.1	135.1	136.3	137.1	138.2	137.8
Avg of conn	20.5	20.8	20.4	20.0	20.0	20.0
Sum of correct	55	60	61	100	100	100
Avg of fitness	0.985	0.983	0.991	0.999	0.999	0.999
Avg of fitness2	0.986	0.984	0.992	1.000	1.000	1.000
Avg of fitness3	0.991	0.989	0.996	1.000	1.000	1.000
Avg of missing3	277.3	292.6	124.5	0.0	0.0	0.0
Avg of left3	9.9	34.5	0.0	0.0	0.0	0.0
Noise level 2%	P01	P02	P05	P10	P20	P50
Avg of $a > b \geq 3$	119.9	117.6	121.8	125.0	126.6	129.4
Avg of $a > b$ (max 130)	142.1	141.7	144.0	145.0	145.2	146.5
Avg of conn	20.5	20.8	20.4	20.0	20.0	20.0
Sum of correct	54	60	61	100	100	100
Avg of fitness	0.984	0.982	0.990	0.998	0.998	0.998
Avg of fitness2	0.986	0.984	0.992	1.000	1.000	1.000
Avg of fitness3	0.991	0.989	0.996	1.000	1.000	1.000
Avg of missing3	276.7	288.4	120.0	0.0	0.0	0.0
Avg of left3	18.0	37.5	0.0	0.0	0.0	0.0
Noise level 5%	P01	P02	P05	P10	P20	P50
Avg of $a > b \geq 3$	122.9	121.1	125.1	127.7	129.7	132.1
Avg of $a > b$ (max 130)	159.2	161.2	160.2	161.7	162.7	164.6
Avg of conn	20.5	20.8	20.4	20.0	20.0	20.0
Sum of correct	55	60	62	100	100	100
Avg of fitness	0.980	0.980	0.987	0.994	0.994	0.994
Avg of fitness2	0.986	0.985	0.992	1.000	1.000	1.000
Avg of fitness3	0.990	0.989	0.996	1.000	1.000	1.000
Avg of missing3	291.1	276.0	119.4	0.0	0.0	0.0
Avg of left3	18.0	57.6	0.0	0.0	0.0	0.0
Noise level 10%	P01	P02	P05	P10	P20	P50
Avg of $a > b \geq 3$	131.3	128.7	132.8	135.1	136.6	139.2
Avg of $a > b$ (max 130)	179.6	177.8	180.3	181.9	182.5	183.0
Avg of conn	20.5	20.8	20.4	20.0	20.0	20.0
Sum of correct	57	61	60	100	100	100
Avg of fitness	0.975	0.973	0.981	0.989	0.989	0.989
Avg of fitness2	0.986	0.984	0.992	1.000	1.000	1.000
Avg of fitness3	0.989	0.986	0.996	1.000	1.000	1.000
Sum of correct	57	61	60	100	100	100
Avg of missing3	301.7	340.3	125.1	0.0	0.0	0.0
Avg of left3	39.3	83.6	0.0	0.0	0.0	0.0
Noise level 20%	P01	P02	P05	P10	P20	P50
Avg of $a > b \geq 3$	144.7	142.8	145.5	149.2	151.0	153.1
Avg of $a > b$ (max 130)	201.8	202.0	203.6	206.2	206.4	208.1
Avg of conn	20.7	20.9	20.6	20.2	20.1	20.1
Sum of correct	49	58	62	98	100	100
Avg of fitness	0.965	0.963	0.970	0.977	0.977	0.977
Avg of fitness2	0.986	0.985	0.991	1.000	1.000	1.000
Avg of fitness3	0.986	0.984	0.996	1.000	1.000	1.000
Avg of missing3	330.0	347.4	109.7	10.4	0.0	0.0
Avg of left3	99.6	133.8	19.2	0.0	0.0	0.0
Noise level 50%	P01	P02	P05	P10	P20	P50
Avg of $a > b \geq 3$	178.7	175.1	179.4	184.0	184.7	186.9
Avg of $a > b$ (max 130)	232.9	231.5	233.3	235.6	236.2	237.8
Avg of conn	27.4	27.6	27.4	26.4	26.6	26.7
Sum of correct	36	40	45	69	73	61
Avg of fitness	0.927	0.930	0.937	0.941	0.942	0.938
Avg of fitness2	0.974	0.975	0.982	0.990	0.991	0.987
Avg of fitness3	0.974	0.970	0.984	0.990	0.990	0.987
Avg of missing3	750.9	718.7	415.5	290.4	280.0	360.0
Avg of left3	53.0	209.0	81.6	30.8	15.1	40.5

Table 9. Performance results for the 6 x 6 x 10 x 10 B1 experiments (imbalance, incompleteness and noise).

B2 material: Average results (6 x 6 x 10 x 10 experiments)						
Noise level 1%	P01	P02	P05	P10	P20	P50
Avg of $a > b \geq 3$	162.8	160.1	173.5	166.7	173.2	177.9
Avg of $a > b$ (max 183)	181.2	182.6	187.6	186.2	188.4	191.2
Avg of conn	27.1	26.9	27.1	26.9	27.0	27.0
Sum of correct	43	34	79	84	96	100
Avg of fitness	0.990	0.981	0.993	0.997	0.999	0.999
Avg of fitness2	0.990	0.981	0.993	0.997	1.000	1.000
Avg of fitness3	0.985	0.980	0.994	0.997	1.000	1.000
Avg of missing3	728.2	1000.8	262.3	157.2	19.0	0.0
Avg of left3	95.1	93.9	61.2	28.4	2.2	0.0
Noise level 2%	P01	P02	P05	P10	P20	P50
Avg of $a > b \geq 3$	163.0	160.3	173.7	167.0	173.5	178.1
Avg of $a > b$ (max 183)	190.3	190.5	196.1	194.1	196.5	198.0
Avg of conn	27.1	26.9	27.1	26.9	27.0	27.0
Sum of correct	43.0	34.0	79.0	84.0	96.0	100.0
Avg of fitness	1	1	1	1	1	1
Avg of fitness2	0.990	0.982	0.993	0.997	1.000	1.000
Avg of fitness3	0.985	0.981	0.994	0.997	1.000	1.000
Avg of missing3	736.780	981.530	262.280	157.150	18.990	0.000
Avg of left3	93.7	97.3	61.2	28.4	2.2	0.0
Noise level 5%	P01	P02	P05	P10	P20	P50
Avg of $a > b \geq 3$	165.4	162.9	176.0	169.3	175.5	180.3
Avg of $a > b$ (max 183)	208.4	209.9	215.5	213.2	215.5	217.6
Avg of conn	27.1	26.9	27.0	26.9	27.0	27.0
Sum of correct	42	35	78	84	96	100
Avg of fitness	0.986	0.979	0.991	0.994	0.997	0.997
Avg of fitness2	0.989	0.981	0.993	0.997	1.000	1.000
Avg of fitness3	0.984	0.981	0.994	0.997	1.000	1.000
Avg of missing3	804.1	986.6	251.1	157.2	19.0	0.0
Avg of left3	103.0	96.7	63.4	28.4	2.2	0.0
Noise level 10%	P01	P02	P05	P10	P20	P50
Avg of $a > b \geq 3$	172.8	171.4	183.3	176.5	182.7	186.9
Avg of $a > b$ (max 183)	230.0	230.6	236.8	234.6	237.9	239.6
Avg of conn	27.1	26.8	27.0	26.9	27.0	27.0
Sum of correct	42	31	78	81	96	100
Avg of fitness	0.983	0.978	0.988	0.991	0.993	0.994
Avg of fitness2	0.989	0.982	0.994	0.997	1.000	1.000
Avg of fitness3	0.984	0.980	0.995	0.996	1.000	1.000
Avg of missing3	809.1	973.5	241.1	167.4	19.0	0.0
Avg of left3	107.5	117.4	63.4	29.8	2.2	0.0
Noise level 20%	P01	P02	P05	P10	P20	P50
Avg of $a > b \geq 3$	187.9	189.1	199.0	192.2	198.3	202.3
Avg of $a > b$ (max 183)	256.3	255.5	264.1	261.7	266.1	269.1
Avg of conn	27.3	26.9	27.0	26.9	27.0	27.0
Sum of correct	44	31	80	80	94	99
Avg of fitness	0.978	0.972	0.983	0.985	0.986	0.988
Avg of fitness2	0.989	0.981	0.994	0.998	1.000	1.000
Avg of fitness3	0.984	0.980	0.995	0.996	0.999	1.000
Avg of missing3	769.5	1018.6	219.1	163.9	32.5	2.2
Avg of left3	115.5	118.2	59.3	34.9	2.2	2.2
Noise level 50%	P01	P02	P05	P10	P20	P50
Avg of $a > b \geq 3$	221.6	222.6	235.6	228.3	235.5	238.5
Avg of $a > b$ (max 183)	294.7	286.4	301.4	299.0	306.0	308.2
Avg of conn	31.2	29.4	29.8	30.6	30.4	30.2
Sum of correct	39	29	78	73	95	94
Avg of fitness	0.965	0.961	0.969	0.968	0.970	0.970
Avg of fitness2	0.990	0.980	0.994	0.996	1.000	0.999
Avg of fitness3	0.982	0.976	0.995	0.995	0.999	0.999
Avg of missing3	874.6	1155.3	209.8	244.4	31.2	45.7
Avg of left3	116.2	194.7	80.2	56.1	4.4	7.5

Table 10. Performance results for the 6 x 6 x 10 x 10 B2 experiments (imbalance, incompleteness and noise).

B3 material: Average results (6 x 6 x 10 x 10 experiments)						
Noise level 1%	P01	P02	P05	P10	P20	P50
Average of $a > b \geq 3$	273.3	247.8	273.6	289.3	304.9	316.1
Average of $a > b$ (max 339)	311.8	296.4	317.5	322.5	330.1	337.3
Average of conn	37.2	37.1	37.3	36.8	37.0	37.0
Sum of correct	31	24	31	55	91	100
Average of fitness	0.983	0.978	0.978	0.992	0.998	0.999
Average of fitness2	0.984	0.978	0.979	0.992	0.999	1.000
Average of fitness3	0.980	0.976	0.976	0.991	0.998	1.000
Average of missing3	964.2	1211.5	1263.1	424.4	86.4	0.0
Average of left3	178.9	166.5	99.3	79.6	9.7	0.0
Noise level 2%	P01	P02	P05	P10	P20	P50
Average of $a > b \geq 3$	273.6	248.0	273.7	289.5	305.2	316.3
Average of $a > b$ (max 339)	320.9	303.7	326.0	331.4	338.6	344.6
Average of conn	37.2	37.1	37.2	36.8	37.0	37.0
Sum of correct	31	24	32	57	90	100
Average of fitness	0.950	0.950	0.966	0.979	0.985	0.997
Average of fitness2	0.984	0.978	0.979	0.993	0.999	1.000
Average of fitness3	0.980	0.975	0.976	0.992	0.998	1.000
Average of missing3	948.7	1229.0	1237.4	399.8	87.8	0.0
Average of left3	184.0	168.0	99.9	77.8	11.0	0.0
Noise level 5%	P01	P02	P05	P10	P20	P50
Average of $a > b \geq 3$	275.7	250.2	275.6	291.7	307.0	317.9
Average of $a > b$ (max 339)	341.0	324.2	345.5	351.1	358.8	364.9
Average of conn	37.2	37.1	37.3	36.8	37.0	37.0
Sum of correct	30	24	31	56	89	100
Average of fitness	0.982	0.975	0.976	0.990	0.996	0.997
Average of fitness2	0.984	0.978	0.979	0.993	0.999	1.000
Average of fitness3	0.980	0.975	0.976	0.992	0.998	1.000
Average of missing3	945.5	1251.6	1276.2	401.1	89.1	0.0
Average of left3	184.4	169.1	99.6	79.2	12.3	0.0
Noise level 10%	P01	P02	P05	P10	P20	P50
Average of $a > b \geq 3$	283.3	257.2	282.1	297.0	313.6	324.2
Average of $a > b$ (max 339)	366.2	349.5	369.1	374.4	383.9	389.9
Average of conn	37.2	37.1	37.2	36.8	37.0	37.0
Sum of correct	29	25	32	55	90	98
Average of fitness	0.978	0.973	0.974	0.985	0.992	0.994
Average of fitness2	0.983	0.978	0.980	0.991	0.998	1.000
Average of fitness3	0.979	0.976	0.976	0.990	0.998	1.000
Average of missing3	993.0	1212.9	1229.1	495.5	109.7	2.7
Average of left3	185.5	171.9	104.3	83.3	10.6	2.7
Noise level 20%	P01	P02	P05	P10	P20	P50
Average of $a > b \geq 3$	299.0	272.7	297.3	312.7	328.5	338.8
Average of $a > b$ (max 339)	397.7	380.7	404.6	407.7	414.5	423.9
Average of conn	37.1	37.1	37.2	36.8	37.0	37.0
Sum of correct	30	23	28	54	88	100
Average of fitness	0.972	0.966	0.966	0.979	0.986	0.988
Average of fitness2	0.983	0.977	0.978	0.991	0.998	1.000
Average of fitness3	0.977	0.974	0.975	0.990	0.998	1.000
Average of missing3	1107.4	1289.6	1327.6	486.7	102.1	0.0
Average of left3	199.4	178.2	103.7	86.9	12.8	0.0
Noise level 50%	P01	P02	P05	P10	P20	P50
Average of $a > b \geq 3$	335.3	310.6	335.2	349.3	366.2	377.4
Average of $a > b$ (max 339)	448.0	429.7	455.4	460.2	467.8	474.3
Average of conn	40.1	39.8	39.4	38.8	39.1	38.7
Sum of correct	17	12	25	47	63	87
Average of fitness	0.953	0.954	0.947	0.960	0.964	0.970
Average of fitness2	0.987	0.981	0.977	0.990	0.994	0.999
Average of fitness3	0.972	0.975	0.973	0.989	0.994	0.999
Average of missing3	1377.3	1182.3	1375.0	525.5	313.2	68.0
Average of left3	185.5	250.7	138.9	112.7	37.1	7.5

Table 11. Performance results for the 6 x 6 x 10 x 10 B3 experiments (imbalance, incompleteness and noise).

B4 material: Average results (6 x 6 x 10 x 10 experiments)						
Noise level 1%	P01	P02	P05	P10	P20	P50
Average of $a > b \geq 3$	232.9	214.4	233.1	246.4	257.4	266.0
Average of $a > b$ (max 274)	262.4	252.6	267.1	271.7	275.7	279.5
Average of conn	34.1	34.0	34.1	33.8	34.0	34.0
Sum of correct	6	10	20	40	62	94
Average of fitness	0.951	0.951	0.967	0.980	0.986	0.998
Average of fitness2	0.952	0.952	0.968	0.980	0.987	0.998
Average of fitness3	0.949	0.953	0.961	0.980	0.988	0.999
Average of missing3	2303.0	2126.6	1849.5	910.8	539.5	60.4
Average of left3	364.8	304.6	197.5	124.5	59.6	9.4
Noise level 2%	P01	P02	P05	P10	P20	P50
Average of $a > b \geq 3$	233.1	214.8	233.3	246.6	257.6	266.3
Average of $a > b$ (max 274)	271.0	260.0	275.0	279.5	284.2	287.7
Average of conn	34.1	34.0	34.1	33.8	34.0	34.0
Sum of correct	6.0	9.0	20.0	37.0	61.0	93.0
Average of fitness	1	1	1	1	1	1
Average of fitness2	0.952	0.951	0.967	0.980	0.987	0.998
Average of fitness3	0.949	0.952	0.960	0.980	0.989	0.998
Average of missing3	2316.2	2170.9	1890.4	930.2	534.4	70.4
Average of left3	345.1	305.2	196.1	126.5	59.5	11.0
Noise level 5%	P01	P02	P05	P10	P20	P50
Average of $a > b \geq 3$	236.0	217.3	236.0	248.8	259.6	268.2
Average of $a > b$ (max 274)	289.3	279.5	293.5	296.1	301.3	305.4
Average of conn	34.1	34.0	34.1	33.8	34.0	34.0
Sum of correct	6	9	18	38	61	90
Average of fitness	0.949	0.947	0.961	0.976	0.983	0.994
Average of fitness2	0.952	0.950	0.964	0.979	0.986	0.998
Average of fitness3	0.948	0.951	0.957	0.979	0.988	0.998
Average of missing3	2329.8	2215.1	2022.4	954.5	573.8	82.0
Average of left3	354.0	315.7	194.9	126.2	66.4	18.9
Noise level 10%	P01	P02	P05	P10	P20	P50
Average of $a > b \geq 3$	243.4	224.8	242.2	256.0	266.3	274.7
Average of $a > b/130$	310.6	300.3	313.8	318.0	322.8	326.5
Average of conn	34.1	34.0	34.0	33.8	34.0	34.0
Sum of correct	5	8	19	39	56	93
Average of fitness	0.946	0.943	0.961	0.973	0.978	0.991
Average of fitness2	0.953	0.949	0.967	0.980	0.985	0.998
Average of fitness3	0.949	0.952	0.960	0.980	0.986	0.998
Average of missing3	2280.8	2200.0	1874.1	939.9	630.6	70.6
Average of left3	372.3	313.6	210.8	126.5	74.5	11.0
Noise level 20%	P01	P02	P05	P10	P20	P50
Average of $a > b \geq 3$	258.4	239.8	257.6	270.4	281.8	290.1
Average of $a > b$ (max 274)	336.1	324.3	340.4	343.0	349.2	351.9
Average of conn	34.0	34.0	34.0	33.8	34.0	34.0
Sum of correct	4	7	15	33	56	84
Average of fitness	0.942	0.938	0.952	0.964	0.972	0.982
Average of fitness2	0.955	0.950	0.966	0.978	0.986	0.996
Average of fitness3	0.948	0.951	0.959	0.977	0.987	0.996
Average of missing3	2306.8	2205.3	1929.3	1041.9	587.2	161.6
Average of left3	387.9	339.0	219.9	147.6	70.7	33.1
Noise level 50%	P01	P02	P05	P10	P20	P50
Average of $a > b \geq 3$	291.9	272.9	291.8	303.5	315.2	322.9
Average of $a > b$ (max 274)	377.2	364.1	380.1	381.5	388.2	389.4
Average of conn	37.8	37.3	37.0	36.9	36.9	36.7
Sum of correct	3	1	18	29	41	78
Average of fitness	0.927	0.922	0.932	0.945	0.953	0.964
Average of fitness2	0.938	0.951	0.963	0.978	0.986	0.997
Average of fitness3	0.946	0.949	0.956	0.977	0.986	0.996
Average of missing3	2449.3	2283.8	2025.0	1056.5	593.5	142.8
Average of left3	382.9	353.4	245.6	139.0	120.5	41.9

Table 12. Performance results for the 6 x 6 x 10 x 10 B4 experiments (imbalance, incompleteness and noise).

activity, the construction the input- and output expressions and Step (3) the search for long distance dependency relations. Simultaneously we introduced a new process modelling language (e.g. Causal Matrices) and we illustrate the advantages of Causal Matrices during the mining of hidden activities. In the experimental session we first illustrate how the HeuristicsMiner can deal with noise and low frequent behavior. In practical situation (i.e. with event log with thousands of traces, low frequent behavior and some noise) the HeuristicsMiner can focus on all behavior in the event log, or only the main behavior. After that, we introduced material (12.000 different event logs) and measurements by which the performance of process mining algorithms can be measured. Finally, the benchmark material and the measurements are used for measuring the mining performance of the HeuristicsMiner. The most striking results is the robustness of the HeuristicsMiner for noise.

Although our approach is based on Causal Matrices, it can be applied to other models with executable semantics, e.g., formalizations of Petri nets, EPCs, BPMN, or UML activity diagrams. In our future work, we would like to extend the benchmark with more realistic material (i.e. from real processes) so that it becomes possible to benchmark also the other process mining perspectives: the organizational, social, performance, and the case perspective. Besides this, research for better process performance measurements remains challenging (ref xxx BPM 06). An other priority is to apply process mining in a wide variety of practical situations.

References

1. W.M.P. van der Aalst, B.F. van Dongen, J. Herbst, L. Maruster, G. Schimm, and A.J.M.M. Weijters. Workflow Mining: A Survey of Issues and Approaches. *Data and Knowledge Engineering*, 47(2):237–267, 2003.
2. W.M.P. van der Aalst and A.J.M.M. Weijters, editors. *Process Mining*, Special Issue of Computers in Industry, Volume 53, Number 3. Elsevier Science Publishers, Amsterdam, 2004.
3. W.M.P. van der Aalst, A.J.M.M. Weijters, and L. Maruster. Workflow Mining: Discovering Process Models from Event Logs. *IEEE Transactions on Knowledge and Data Engineering*, 16(9):1128–1142, 2004.
4. A.K. Alves de Medeiros. *Genetic Process Mining*. PhD thesis, Eindhoven, University of Technology, Eindhoven, The Netherlands, 2006.
5. B. van Dongen, A.K. Alves de Medeiros, H.M.W. Verbeek, A.J.M.M. Weijters, and W.M.P. van der Aalst. The ProM framework: A New Era in Process Mining Tool Support. In G. Ciardo and P. Darondeau, editors, *Application and Theory of Petri Nets 2005*, volume 3536 of *Lecture Notes in Computer Science*, pages 444–454. Springer-Verlag, Berlin, 2005.
6. L. Maruster, W.M.P. van der Aalst, A.J.M.M. Weijters, A. van den Bosch, and W. Daelemans. Automated Discovery of Workflow Models from Hospital Data. In C. Dousson, F. Höppner, and R. Quiniou, editors, *Proceedings of the ECAI Workshop on Knowledge Discovery and Spatial Data*, pages 32–36, 2002.
7. A.K.A. de Medeiros, A.J.M.M. Weijters, and W.M.P. van der Aalst. Using Genetic Algorithms to Mine Process Models: Representation, Operators and Results.

- BETA Working Paper Series, WP 124, Eindhoven University of Technology, Eindhoven, 2004.
8. A.K.A. de Medeiros, A.J.M.M. Weijters, and W.M.P. van der Aalst. Genetic Process Mining: A Basic Approach and its Challenges. In C. Bussler et al., editor, *BPM 2005 Workshops (Workshop on Business Process Intelligence)*, volume 3812 of *Lecture Notes in Computer Science*, pages 203–215. Springer-Verlag, Berlin, 2006.
 9. W. Reisig and G. Rozenberg, editors. *Lectures on Petri Nets I: Basic Models*, volume 1491 of *Lecture Notes in Computer Science*. Springer-Verlag, Berlin, 1998.
 10. J. Scott. *Social Network Analysis*. Sage, Newbury Park CA, 1992.
 11. L. Wen, J. Wang, and J. Sun. Detecting implicit dependencies between tasks from event logs. In X. Zhou, J. Li, H.T. Shen, M. Kitsuregawa, and Y. Zhang, editors, *Proc. of the APWeb conference*, volume 3841 of *LNCS*, pages 591–603. Springer Verlag, 2006.

Appendix

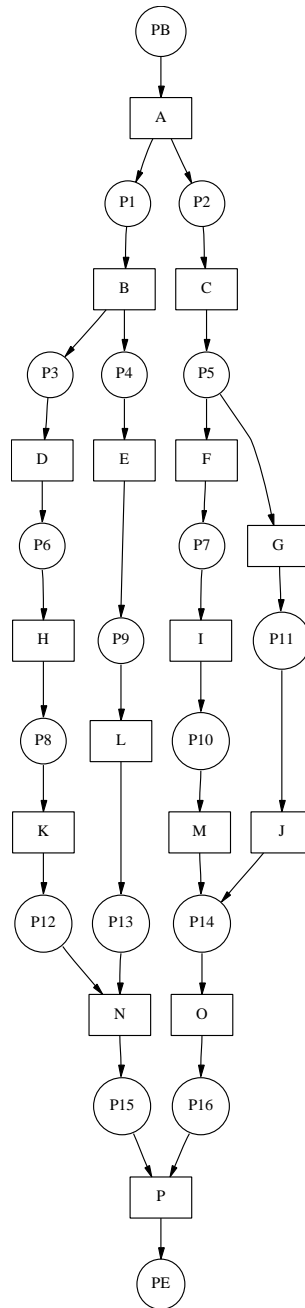

Fig. 7. Petri net B1 with 16 tasks, without loops.

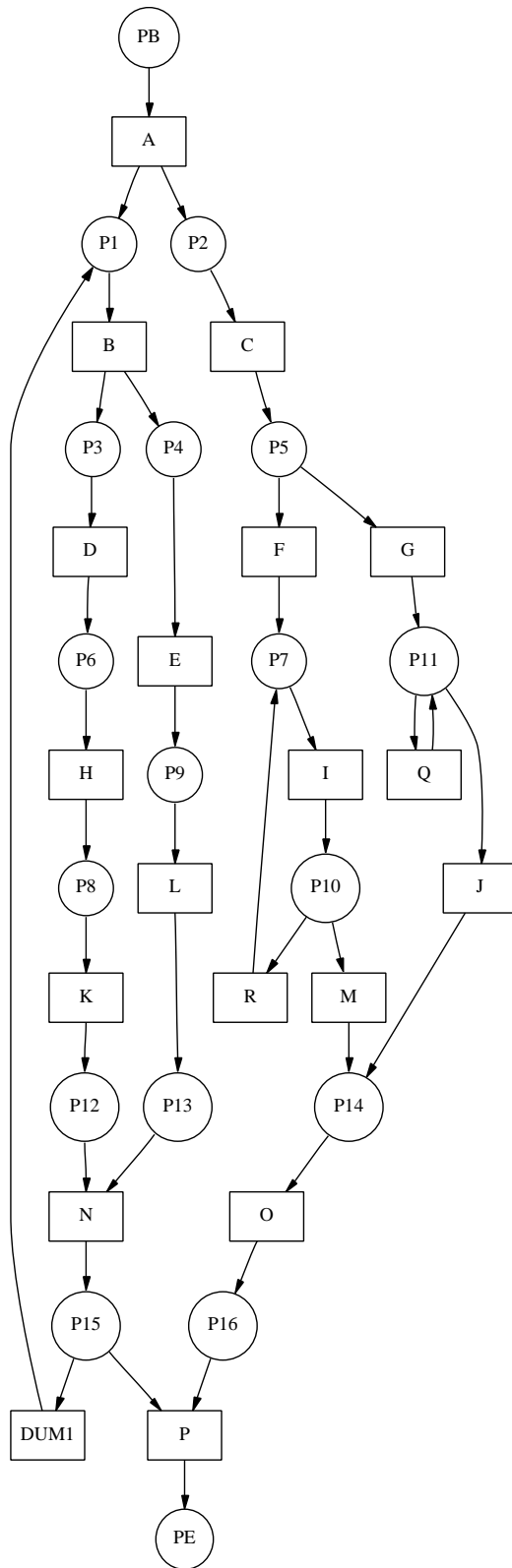

Fig. 8. Petri net B2. It is an extension of net b1 with different types of loops (i.e. a long loop, a length two loop and recursion).

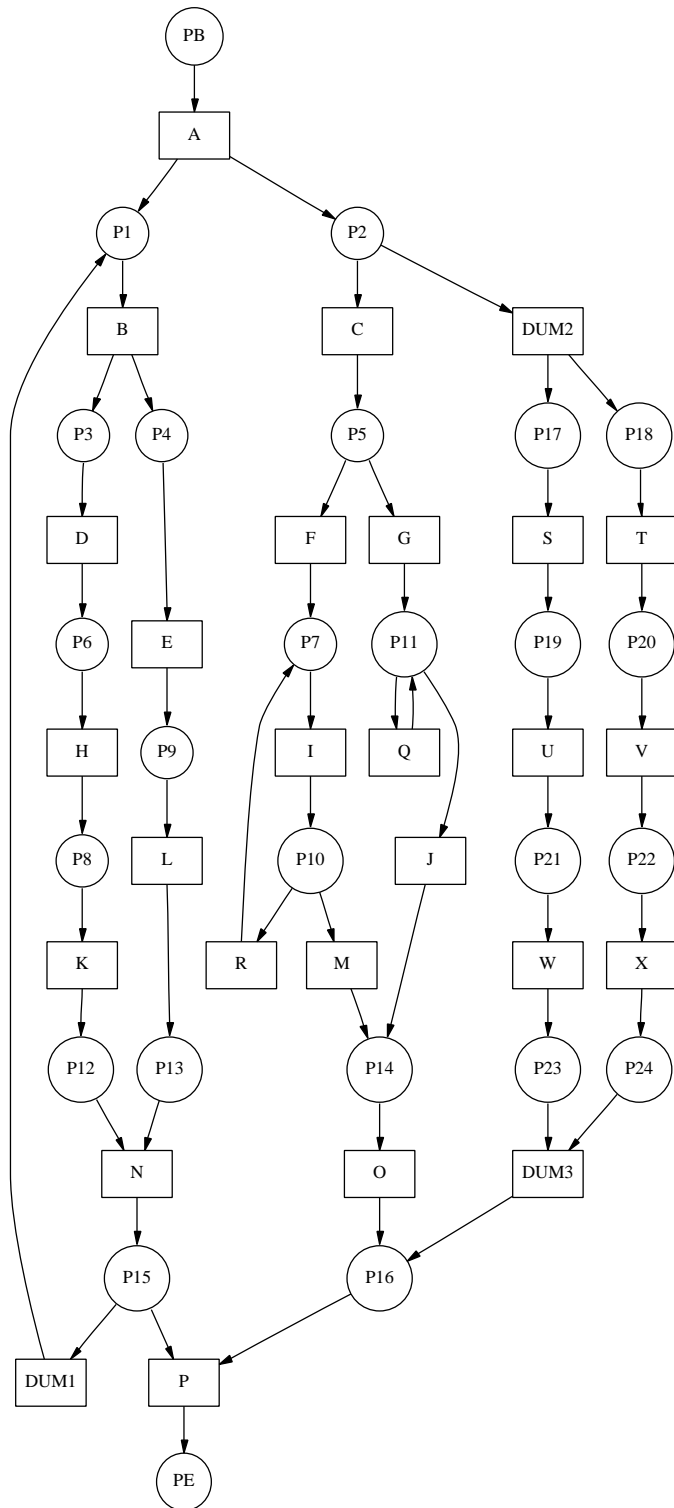

Fig. 9. Petri net B3 (and B4) is an extension of b2 with extra parallel behavior. In the event logs of the b3 experiments the non-observable tasks (DUM1, DUM2, and DUM3) are recorded in the event log, in the B4 experiments this tasks are not registered in the log.

```

Procedure LongDistanceDependency;
var i,j: Integer;
    Score, HNC: Real;
begin
  For i:=N_events downto 1 do
  begin
    For j:=N_events downto 1 do
    begin
      LongDistanceDependency := (|Event[i]>>>Event[j]| /
        |Event[i]|+1) - (||Event[i]| - |Event[j]|||/|Event[i]|);
      If (|Event[i]>>>Event[j]|>=AbsUseThres) and (LongDistanceDependency>=AbsThres)) then
      begin
        If EscapeToEndPossible(Event[i],Event[j],[]) then
          addConnection(Event[i],Event[j]);
        end;
      end;
    end;
  end;
end;

Function EscapeToEndPossibleF(Event[x], Event[y]: ActivityT; VisitedS: IntSetT): Boolean;
var i,j: Integer;
    Max, Min, MinHulp: Real;
begin
  If ((x in VisitedS) or (x==y) or (Event[y]==EndActivity)) then
  begin
    EscapeToEndPossibleF:=False; Exit;
  end;
  With Event[x] do
  begin
    If (Card(OutOrCluster[1], N_events) = 0) then
      // X is eEe event
      begin
        EscapeToEndPossibleF := True; Exit;
      end;
    // iteration over the OR-subsets
    For i:=1 to N_output_clusters do
    begin
      // Test if output set i has at least one eEe-escape!
      OutOrEscapePossible := False;
      For j:=1 to N_Events do
      begin
        If (j in OutOrCluster[i]) then
        begin
          if EscapeToEndPossibleF(Event[j], Event[y], VisitedS + [Event[x]]) then
            OrSetEscapePossible := True;
          end;
        end;
      end;
      // If there is not a eEe-escape for i
      If (Not OrSetEscapePossible) then
      begin
        EscapeToEndPossibleF:=False; Exit;
      end;
    end;
    // For all i-OR sets escaping is possible
    EscapeToEndPossibleF:=True;
  end; // EndWith
end;

```

Table 13. Pseudo code for the “long-distance-dependency-heuristic”.