

The effect of vancomycin and tobramycin on the tensile properties of cured low viscosity bone cements

Citation for published version (APA):

Argenson, J. N., Verdonschot, N. J. J., Seyral, P., & Huiskes, H. W. J. (1994). The effect of vancomycin and tobramycin on the tensile properties of cured low viscosity bone cements. *European Journal of Experimental Musculoskeletal Research*, 3(1), 43-47. <https://doi.org/10.1159/000259146>

DOI:

[10.1159/000259146](https://doi.org/10.1159/000259146)

Document status and date:

Published: 01/01/1994

Document Version:

Publisher's PDF, also known as Version of Record (includes final page, issue and volume numbers)

Please check the document version of this publication:

- A submitted manuscript is the version of the article upon submission and before peer-review. There can be important differences between the submitted version and the official published version of record. People interested in the research are advised to contact the author for the final version of the publication, or visit the DOI to the publisher's website.
- The final author version and the galley proof are versions of the publication after peer review.
- The final published version features the final layout of the paper including the volume, issue and page numbers.

[Link to publication](#)

General rights

Copyright and moral rights for the publications made accessible in the public portal are retained by the authors and/or other copyright owners and it is a condition of accessing publications that users recognise and abide by the legal requirements associated with these rights.

- Users may download and print one copy of any publication from the public portal for the purpose of private study or research.
- You may not further distribute the material or use it for any profit-making activity or commercial gain
- You may freely distribute the URL identifying the publication in the public portal.

If the publication is distributed under the terms of Article 25fa of the Dutch Copyright Act, indicated by the "Taverne" license above, please follow below link for the End User Agreement:

www.tue.nl/taverne

Take down policy

If you believe that this document breaches copyright please contact us at:

openaccess@tue.nl

providing details and we will investigate your claim.

The Effect of Vancomycin and Tobramycin on the Tensile Properties of Cured Low Viscosity Bone Cements

JEAN-NOEL ARGENSON, MD,¹ NICO VERDONSCHOT, PhD,² PHILIPPE SEYRAL, MD,³ and RICK HUISKES, PhD²

From the ¹Department of Orthopaedic Surgery, Aix-Marseille University, Hospital Sainte-Marguerite, Marseille,

²Institute of Biomechanics, Nijmegen University, Nijmegen, The Netherlands, and ³Department of Microbiology, Aix-Marseille University, Hospital La Timone, Marseille, France

Argenson J-N, Verdonschot N, Seyral P, Huiskes R. The effect of vancomycin and tobramycin on the tensile properties of cured low viscosity bone cements. Eur J Exp Musculoskel Res 1994; 3: 43-47.

Samples of plain and vancomycin-tobramycin loaded low viscosity cements were evaluated for their tensile mechanical properties. Vancomycin is effective against nearly all resistant pathogens now involved in prosthesis infection. The mechanical properties of vancomycin-impregnated cement have never been studied. Tobramycin extends the spectrum to Gram negative bacteria and has been well studied as used in bone cement. This antibiotic mixture covers most of the pathogens resulting from arthroplasty thus providing an active local prophylaxis against infection. Specimens of four low viscosity bone cements were machined, radiographed and tested. The addition of 2 g of vancomycin in 40 g of cement powder did not significantly affect the tensile properties of the four cements. Simultaneous addition of vancomycin (2 g) and tobramycin (1 g) significantly decreased the tensile strength and fracture strain of one cement, but the absolute values remained equal to the others or higher and well above the levels reported with standard viscosity cements. Vancomycin-tobramycin has been shown to fulfill the criteria required for diffusion and antimicrobial activity after admixing in bone cement. This study shows that the effects of such a combination on the tensile properties of four low viscosity bone cements are acceptable. *Key words: arthroplasty, cement, elastic modulus, fracture strain, infection, low viscosity, resistant pathogens, tensile strength, tobramycin, vancomycin.*

INTRODUCTION

Infection remains the most serious short-term complication following total joint arthroplasty. Methods of reducing its frequency include meticulous surgical technique, improved surgical environment using laminar flow, and the use of prophylactic systemic antibiotics.

Antibiotics may also be added to the bone cement and have been proposed either for prophylaxis or treatment of infections in orthopaedic surgery (1). Gentamycin has been the most commonly used antibiotic, but resistance to this compound has increased in recent years and major bacterial pathogens involved in infected arthroplasties, such as staphylococci and pseudomonas, are now frequently resistant to gentamycin.

The purpose of this study was to investigate whether the tensile mechanical properties of four low viscosity bone cements are affected when admixed with vancomycin and tobramycin. We chose these antibiotics because vancomycin is effective against nearly all staphylococci and tobramycin is effective against pseudomonas.

MATERIALS AND METHODS

Four low-viscosity cements were used throughout the study: CMW3 (CMW, Exeter, U.K.), LVC (Zimmer, Warsaw, Indiana, USA), Palacos BV (Schering-

Plough, Levallois, France), and Sulfix 60 (Allopro-Sulzer, Winterthur, Switzerland). For each cement, four tests were conducted: without antibiotics, with 2 g of vancomycin and 1 g of tobramycin, with 4 g of vancomycin and 2 g of tobramycin, and with 2 g of vancomycin alone. The antibiotic powder was added to the polymer powder and mixed thoroughly by hand. The powder and the monomer were then mixed according to the manufacturer's instructions for 2 min at a rate of about 100 cycles per min. For each test several specimens were studied (Table 1).

The mould that was used for the production of the bone cement specimens for the tension tests consisted of an aluminium box with a lid. It was covered on the inside by a 1 cm polytetrafluoroethylene (PTFE) layer. The cement filling space in the box was 5 × 46 × 200 mm. In the four corners of the box, there were holes to allow excess cement to escape when the box was closed. After curing under pressure (by applying a load of approximately 5 kg) for 18 min at 24°C, a 5 mm thick bone cement plate could be obtained from the mould.

After moulding, the specimens were machined according to DIN 53-455 on a Bridgeport CNC mill to a dumbbell shape. X-rays were taken of each specimen, so that the internal void distribution could be visualized and large deficiencies in mechanical properties be interpreted. Specimens with voids in the radius that would obviously lead to failure were discarded. The

Table I. Number of specimens tested for each low viscosity cement for plain cement and after addition of vancomycin and tobramycin

	Number of specimens			
	CMW3	Zimmer LVC	Palacos BV	Sulfix 60
NO AB	4	6	4	4
Va(2 g) + To(1 g)	4	8	4	8
Va(4 g) + To(2 g)	2	4	2	6
Va(2 g)	4	6	4	8

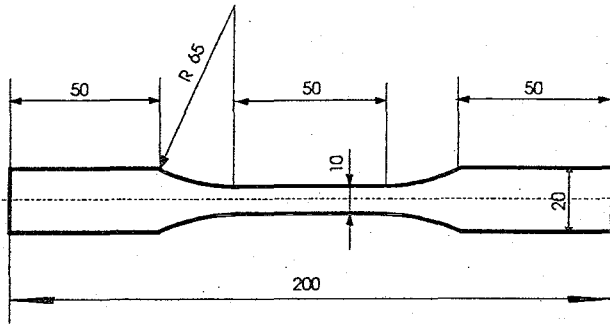

Fig. 1. The shape and dimensions of the tensile test specimens, in mm.

specimens, 20 cm in total length, had a gauge length of 5 cm (Fig. 1). The width (mm) and thickness (mm) of three cross-sections along the gauge length of each specimen were checked with a micrometer around 10 mm and 5 mm, respectively. Mean values were used and the cross-sectional area was calculated, in mm².

After machining, all the specimens were stored at 21°C under a relative humidity of 20% for a minimum of 6 weeks. For tensile testing the specimens were fixed in an Instron testing machine (model TT-CM) by two clamps 10 cm apart. A 5 cm displacement gauge was fixed to the gauge length. The tension tests were performed at a crosshead speed of 25 mm/min. The data were collected by a computer and elastic modulus (MPa), tensile strength (MPa) and fracture strain were determined. A total of 78 specimens were tested. Each specimen came from a single mix of cement. Statistical analysis using the Student's *t*-test was used to compare the means of the tensile strength and fracture strain of the groups with and without antibiotic.

RESULTS

A total of 76 specimens were effectively tested, two of the 78 specimens led to mechanical failure, which was due to the presence of large air voids (>14 mm of radius) in the region of the measuring area. For all

the other specimens (showing voids of <1 mm in radius) the tension test could be conducted routinely.

Figs. 2–4 show the resulting Young's moduli, tensile strengths and fracture strains for the four low viscosity bone cements, with normal cement (P), after addition of single dose (SD) or double dose (DD) of antibiotic (vancomycin + tobramycin) or with vancomycin (Va) alone.

Effect of antibiotic addition

The addition of 2 g of vancomycin did not significantly affect the tensile mechanical properties of the four cements.

The addition of 2 g of vancomycin and 1 g of tobramycin significantly decreased the elastic modulus by 5 to 10%, except for Palacos, which was not affected. The addition of 2 g of vancomycin and 1 g of tobramycin always decreased the tensile strengths of the cements, but the difference was only significant for Sulfix ($p = 0.001$)

The addition of 2 g of vancomycin and 1 g of tobramycin did not significantly affect the fracture strain, except for Sulfix ($p = 0.003$).

The addition of a double dose of antibiotic (vancomycin 4 g + tobramycin 2 g) did not significantly change the results obtained with a single dose.

Tensile properties of the four low viscosity cements

The tensile strength and fracture strain of Palacos BV and Sulfix 60 were significantly higher than those of CNW3 and Zimmer LVC, without any antibiotic ($p < 0.001$; Student's *t* test).

After antibiotic addition, Palacos BV and Sulfix 60 always showed higher tensile strength and fracture strain, but this was not significant in all cases.

After antibiotic addition Palacos BV always had a significantly higher tensile strength than the three other cements.

DISCUSSION

The addition of an antibiotic in polymethylmethacrylate (PMMA) has proved to be efficient in reducing

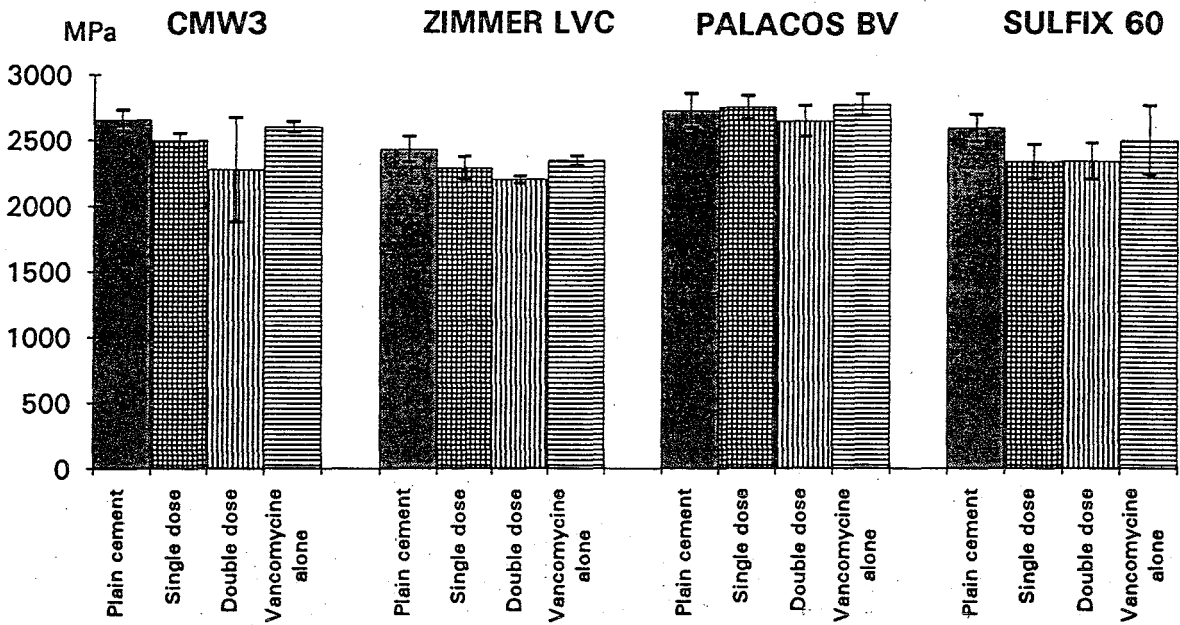

Fig. 2. Elastic modulus of the four low viscosity cements with and without antibiotic admixing. Each bar graph represents the mean of group of specimens listed in Table I, with their standard deviations shown.

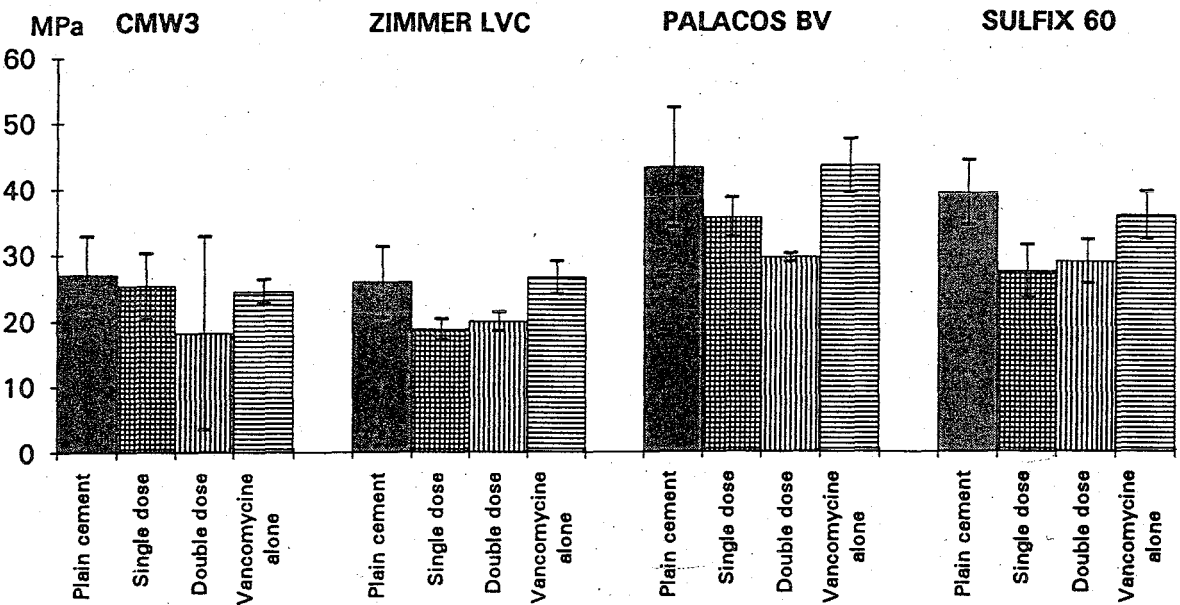

Fig. 3. Tensile strength of the four low viscosity cements with and without antibiotic admixing. Each bar graph represents the mean of group of specimens listed in Table I, with their standard deviations shown.

infection after arthroplasty (2) and has been successfully used in the treatment of infected arthroplasty, where the involved micro-organism is sensitive to the antibiotic admixed in the cement (3). The most common bacterial pathogen involved in joint replacement infection is staphylococcus coagulase positive or negative, which is almost uniformly sensitive to van-

comycin. Tobramycin is effective against Gram negative micro-organisms. The elution of these two antibiotics from PMMA has recently been studied *in vitro* (4), and the antibiotics were found in useful concentrations in the surrounding tissues. In another work (5), measurable concentrations were found after 8 months, with no alteration of the antimicrobial

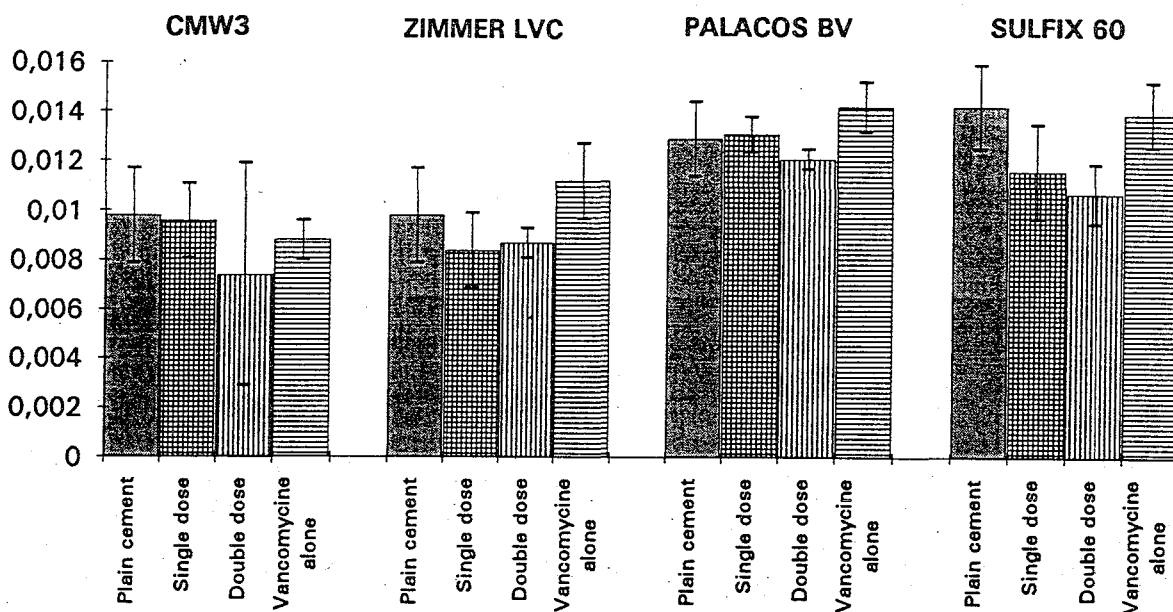

Fig. 4. Fracture strain of the four low viscosity cements with and without antibiotic admixing. Each bar graph represents the mean of group of specimens listed in Table I, with their standard deviations shown.

activity caused by polymerization and no evidence of micro-organism growth after 50 days for vancomycin and 60 days for tobramycin.

The purpose of this study was to investigate the effect on the tensile properties of the cement after addition of antibiotics. Lautenschlager et al. (6, 7) showed the absence of deleterious effects of gentamycin powder of up to 5 g on the tensile properties. Our results with vancomycin confirm the absence of any significant effect on the tensile properties of the four low viscosity cements studied. Simultaneous addition of vancomycin and tobramycin only affects the tensile properties of Sulfix, while the tensile strength and fracture strain remain much higher than for CMW3 and Zimmer LVC.

The tensile strength was 24 to 43 MPa for vancomycin-loaded PMMA for the four low viscosity cements, compared with 18 MPa with conventional viscosity cement loaded with vancomycin, as reported by Lawson et al. (4) for a small number of specimens. These results also compare favourably with previous reports of diametral tensile strength obtained with gentamycin (8). The better mechanical characteristics after antibiotic admixing obtained with low viscosity cements have already been reported in the literature (9).

However, air voids due to poor techniques in the powder mixing can lead to early fractures (10), as was the case for two of our 78 specimens (Fig. 5). New technologies for cement preparation, or industrial powder preparation including antibiotics effective against the common pathogens, may decrease the porosity of the cement.

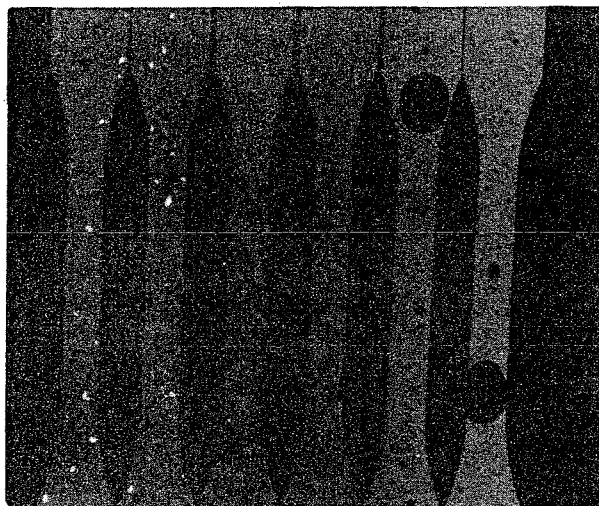

Fig. 5. X-rays of LVC specimens without antibiotic addition showing large voids close to the measuring area. The two specimens on the right were excluded for early mechanical fracture.

Whereas tobramycin has frequently been studied and incorporated in bone cement, very little work has been reported on vancomycin loaded PMMA. This antibiotic appears to fulfil the criteria proposed by Murray (11) for heat stability, elution and antimicrobial spectrum. This study showed its acceptable effects on the tensile mechanical properties of four common low viscosity bone cements.

Clinical use of vancomycin impregnated PMMA has been reported for salvage of infected total knee

arthroplasty (12), and is now currently used in our institution for cemented hip and knee arthroplasty.

REFERENCES

1. Buchholz HW, Elson RA, Heinert K. Antibiotic-loaded acrylic cement: current concepts. *Clin Orthop* 1984; 190: 96-108.
2. Josefsson G, Lindberg L, Wiklander B. Systemic antibiotics and gentamicin-containing bone cement in the prophylaxis of postoperative infections in total hip arthroplasty. *Clin Orthop* 1981; 159: 194-200.
3. Buchholz HW, Engelbrecht H. Über die Depotwirkung einiger Antibiotica bei Vermischung mit dem Kunstharz Palacos. *Chirurg* 1970; 41: 511.
4. Lawson KJ, Marks KE, Brems J, Rehm S. Vancomycin vs. tobramycin elution from polymethylmethacrylate: an *in vitro* study. *Orthopaedics* 1990; 13: 521-4.
5. Seyral P, Zannier A, Argenson JN, Raoult D. The release of vancomycin and tobramycin from acrylic bone cement *in vitro*. *J Antimicrob Chemother* (in press).
6. Lautenschlager EP, Jacobs JJ, Marshall GW, Meyer PR Jr. Mechanical properties of bone cements containing large doses of antibiotic powders. *J Biomed Mater Res* 1976; 10: 929-38.
7. Lautenschlager EP, Marshall GW, Marks KE, Schwartz J, Nelson CL. Mechanical strength of acrylic bone cements impregnated with antibiotics. *J Biomed Mater Res* 1976b; 10: 837-45.
8. Nelson RC, Hoffman RO, Burton TA. The effect of antibiotic additions on the mechanical properties of acrylic cement. *J Biomed Mater Res* 1978; 12: 473-90.
9. Bunetel L, Segui A, Cormier M, Langlais F. Comparative study of gentamicin release from normal and low viscosity acrylic bone cement. *Clin Pharmacokinet* 1990; 19: 333-40.
10. Wright TM, Sullivan DJ, Arnoczky SP. The effect of antibiotic additions on the fracture properties of bone cements. *Acta Orthop Scand* 1984; 55: 414-8.
11. Murray WR. Use of antibiotic-containing bone cement. *Clin Orthop* 1984; 190: 89-95.
12. Wilde AH, Ruth JT. Two-stage reimplantation in infected total knee arthroplasty. *Clin Orthop* 1988; 236: 23-35.

Submitted August 16, 1993; accepted October 12, 1993

Address for correspondence:
 Jean-Noël Argenson
 Aix-Marseille university
 Service de chirurgie orthopédique
 Hôpital Sainte Marguerite
 BP 29
 13274 Marseille Cedex 09
 France