

Bench heating in monumental churches : thermal performance of a prototype

Citation for published version (APA):

Neilen, D. (2006). *Bench heating in monumental churches : thermal performance of a prototype*. [Phd Thesis 1 (Research TU/e / Graduation TU/e), Built Environment]. Technische Universiteit Eindhoven.
<https://doi.org/10.6100/IR614925>

DOI:

[10.6100/IR614925](https://doi.org/10.6100/IR614925)

Document status and date:

Published: 01/01/2006

Document Version:

Publisher's PDF, also known as Version of Record (includes final page, issue and volume numbers)

Please check the document version of this publication:

- A submitted manuscript is the version of the article upon submission and before peer-review. There can be important differences between the submitted version and the official published version of record. People interested in the research are advised to contact the author for the final version of the publication, or visit the DOI to the publisher's website.
- The final author version and the galley proof are versions of the publication after peer review.
- The final published version features the final layout of the paper including the volume, issue and page numbers.

[Link to publication](#)

General rights

Copyright and moral rights for the publications made accessible in the public portal are retained by the authors and/or other copyright owners and it is a condition of accessing publications that users recognise and abide by the legal requirements associated with these rights.

- Users may download and print one copy of any publication from the public portal for the purpose of private study or research.
- You may not further distribute the material or use it for any profit-making activity or commercial gain
- You may freely distribute the URL identifying the publication in the public portal.

If the publication is distributed under the terms of Article 25fa of the Dutch Copyright Act, indicated by the "Taverne" license above, please follow below link for the End User Agreement:

www.tue.nl/taverne

Take down policy

If you believe that this document breaches copyright please contact us at:

openaccess@tue.nl

providing details and we will investigate your claim.

Bench Heating in Monumental Churches Thermal Performance of a Prototype

PROEFSCHRIFT

ter verkrijging van de graad van doctor aan de
Technische Universiteit Eindhoven, op gezag van de
Rector Magnificus, prof.dr.ir. C.J. van Duijn, voor een
commissie aangewezen door het
College voor Promoties in het openbaar te verdedigen op
dinsdag 26 september 2006 om 16.00 uur

door

Dionne Limpens-Neilen

geboren te Sittard

Dit proefschrift is goedgekeurd door de promotor:

prof.dr.ir. M.H. de Wit

Copromotor:

dr.ir. H.L. Schellen

ISBN-10: 90-386-1776-3

ISBN-13: 978-90-386-1776-3

NUR: 955

Bench Heating in Monumental Churches - Thermal Performance of a Prototype / by
Dionne Limpens-Neilen, Eindhoven: Technische Universiteit Eindhoven, 2006

Cover: IR thermograph of comfort study in climate room

Cover design by Jac de Kok

Printed by the Eindhoven University Press, Eindhoven, The Netherlands.

Published as issue 112 in the *Bouwstenen* series of the Faculty of Architecture, Building
and Planning of the Eindhoven University of Technology

Trefwoorden: monumentale kerken / bankverwarming / computersimulaties / thermisch
comfort / klimaatkamer

Subject headings: monumental churches / bench heating / computer simulations / thermal
comfort / climate room

The work described in this thesis has been carried out in the unit Building Physics and Systems at the Eindhoven University of Technology, Department of Architecture, Building and Planning.

This research was funded by the EU commission under contract no: EVK4-CT-2001-00067

The climate data were obtained from the National Research and Information Centre for Climate, Climatic Change and Seismology in the Netherlands (KNMI)

Table of Contents

Samenvatting.....	i
Summary.....	iii
1 Introduction.....	1
1.1 Development of church heating	1
1.2 Risks regarding conservation	2
1.3 Local heating system	4
1.4 Human thermal comfort	5
1.5 European project	6
1.6 Research objectives	7
1.7 Research questions	7
1.8 Outline	7
2 EU-project “Friendly Heating”	9
2.1 Introduction	9
2.2 Project organisation	10
2.3 Church of Rocca Pietore	16
2.4 Heating system	17
2.5 Problem description	17
2.6 Methodology	18
2.7 Local radiant bench heating system	21
2.8 Results	24
2.9 Conclusions	27
3 Experimental set-up.....	29
3.1 Introduction	29
3.2 Configuration climate room set-up	29
3.3 Local heating system	30
3.4 Measurement set-up	33
3.5 Measurement equipment	35
3.6 Measurement procedure	37
3.7 Measurement results	39
3.8 Conclusions	45

4 Thermal Comfort.....	47
4.1 Introduction	48
4.2 Thermal comfort study with volunteers	48
4.3 Equivalent Homogeneous Temperature (EHT)	61
4.4 Predicting thermal comfort with the help of International Standards	62
4.5 Thermophysiological computer model	70
4.6 Conclusions	74
5 Numerical simulations.....	77
5.1 Introduction	77
5.2 CFD	78
5.3 HAMBASE: hygrothermal building simulation tool	96
5.4 Conclusions	101
6 Conclusions and recommendations.....	103
6.1 Conclusions	103
6.2 Recommendations	106
6.3 Recommendations for applying a local radiant heating system	108
References.....	111
List of publications.....	113
Nomenclature.....	119
List of tables and figures.....	123
Appendix A.....	127
A.1 Archimedes number	
Appendix B.....	129
B.1 Necessary parameters to calculate predicted mean vote (PMV) and their recommended interval	129
B.2 Calculation PMV value per volunteer	129
B.3 Questionnaires comfort study volunteers	131
B.4 Measured skin temperatures per heating configuration	134
Dankwoord.....	135
Curriculum vitae.....	139

Samenvatting

Het gebruik van verwarmingssystemen die het hele luchtvolume van een kerk opwarmen, veroorzaakt veel problemen. Vooral in kerken die maar een enkele keer in de week verwarmd worden vormen de abrupte veranderingen in temperatuur en relatieve vochtigheid die hierdoor veroorzaakt worden, de basis van blijvende schade aan het kerkgebouw en het (veelal monumentale) interieur. Het continu verwarmen van de kerk mag dan wel een mogelijke oplossing zijn voor de conservering van het gebouw en interieur, het brengt ook ongewenst hoge energiekosten met zich mee. Het toepassen van een lokaal verwarmingssysteem zou een andere mogelijke oplossing kunnen zijn. Alleen de zone waarin de mensen zich bevinden wordt dan opgewarmd in plaats van de gehele kerk. Op deze manier zou een schadelijk binnenklimaat (te warm en te droog) voorkomen worden, terwijl er wel een thermisch comfortabele situatie wordt gecreëerd voor de mensen in de kerkbanken.

Dit promotieonderzoek is gestart als een onderdeel van het Europese project “Friendly Heating” (een project in het 5e Kaderprogramma van de EU onder contractnummer EVK4-CT-2001-00067) waarin diverse prototypes van een lokaal bankverwarmingssysteem zijn ontworpen, toegepast en getest in de kerk van Rocca Pietore, een klein dorpje in de Italiaanse Dolomieten.

In dit proefschrift is het onderzoek naar de prestaties van drie prototypes van dit lokale bankverwarmingssysteem weergegeven. Met behulp van metingen in een klimaatkamer is het lokale klimaat in de banken, als gevolg van dit bankverwarmingssysteem, onderzocht. De resultaten laten zien dat de invloed van het lokale verwarmingssysteem op het algemene klimaat in de ruimte zeer gering is, hetgeen gunstig is voor het behoud van gebouw en interieur. In de zone van de kerkbanken, wordt de luchttemperatuur met ongeveer 4°C opgewarmd tot een temperatuur van 11°C, de lichtsnelheid in de banken varieert van 0.05m/s tot 0.19m/s, en de stralingstemperatuur bereikt een waarde van 12°C tot 16°C.

Naast deze metingen is er ook een comfortstudie met proefpersonen uitgevoerd. In deze comfortstudie zijn huidtemperaturen van de verschillende lichaamsdelen van de personen gemeten. In combinatie met de resultaten van de vragenlijsten die de personen tijdens de metingen hebben ingevuld (over thermisch gevoel,

thermisch comfort, het ervaren van lichtsnelheden en de thermische voorkeur van de mensen voor een warmer of kouder klimaat), is er een comfortbeoordeling bepaald. Met behulp van twee bestaande internationale standaarden met betrekking tot thermisch comfort (ISO 7730 en ISO/TR 11079) is het thermisch comfort niveau in de banken berekend. Alhoewel de tweede standaard (ISO/TR 11079) specifiek toegespitst is op het thermisch comfort in koude omgevingen, blijkt uit de vergelijking met de comfortmetingen dat deze standaarden geen goede resultaten geven en dus niet toegepast kunnen worden om het thermisch comfort in de banken in te schatten. De standaarden berekenen een statische waarde, terwijl in werkelijkheid een dynamisch effect zichtbaar is: het thermische gevoel/comfort van de mensen neemt af in de tijd. Een thermofysiologisch computer simulatiemodel, dat in ontwikkeling is bij de Faculteit Werktuigbouwkunde, is gebruikt om de huidtemperaturen van een persoon te berekenen/voorspellen. Hoewel er nog verschillen zichtbaar zijn in de temperaturen van de afzonderlijke lichaamsdelen, laat de gemiddelde huidtemperatuur een redelijke overeenkomst zien met die uit de comfortmetingen. Het model is nog steeds in ontwikkeling maar lijkt voor de toekomst hoopgevend voor het voorspellen van het comfort.

Computer simulatiemodellen op zowel gebouw- als detailniveau zijn gebruikt om het lokale klimaat in de kerkbanken te voorspellen en te evalueren. De prestaties van het lokale bankverwarmingssysteem zijn vergeleken met die van het oorspronkelijk aanwezige luchtverwarmingssysteem in de kerk van Rocca Pietore. De resultaten van CFD (Computational Fluid Dynamics) simulaties zijn geverifieerd met behulp van de meetresultaten uit de klimaatkamer. Na deze verificatie zijn de CFD modellen gebruikt om een variantenstudie uit te voeren waarin de mogelijke verbetering van het lokale klimaat in de banken is onderzocht. Uiteindelijk zijn er computerberekeningen gemaakt waarmee de invloed van het lokale verwarmingssysteem op het binnenklimaat van de kerk in Rocca Pietore is voorspeld.

Summary

The use of heating systems warming up the whole indoor air volume causes many problems in churches. Especially in churches which are heated only a few times a week, abrupt changes in temperature and relative humidity are the basis of permanent damage to the building and its works of art. Heating continuously might be a solution to this conservation problem, but this causes high energy costs. Another solution might be to use a local heating system instead of heating the whole church. Since a local heating system only heats the area where the people are, it should prevent a wrong overall indoor climate (too warm and dry) which could cause damage, while providing thermal comfort for the churchgoers. This PhD research started as a part of the European project “Friendly Heating” (a project in the 5th Framework, contract no: EVK4-CT-2001-00067), in which prototypes of a local heating system have been developed and applied to the church in Rocca Pietore, a small village in the Italian Dolomites.

In this thesis, the thermal performance of three prototypes of a local radiant heating system is investigated. Measurements in a climate room have been performed to investigate the local climate in the benches, as it results from operating the local heating system. The results show that the local heating elements only have little influence on the overall climate in the room. In the bench region, the air temperature is raised by approximately 4°C to a temperature level of around 11°C, the air velocities range from 0.05m/s to 0.19m/s, and the radiant temperature in the benches reached a value of about 12°C to 16°C.

In addition to these physical measurements, a thermal comfort study with volunteers has been performed to investigate the human thermal comfort in the benches. This comfort study has been performed by combining skin temperature measurements with questionnaires about thermal sensation, thermal comfort, perception of air movement and people's thermal preference. Two existing comfort standards (ISO 7730 and ISO/TR 11079) were used to predict the thermal comfort level in the benches. Although the latter explicitly focusses on determining cold environments, a comparison of the results of the comfort standards with the results from the comfort study pointed out, that these standards can not be applied to predict the thermal comfort level of people in the benches.

The standards calculate a static value and do not take into account the dynamic effect which is present: the thermal sensation of the people decreases with time. A thermophysiological computer simulation model has been used to calculate (predict) the human skin temperatures. Although the temperatures of individual body parts show some deviations from the skin temperature measurements, the calculated mean skin temperature shows a reasonable agreement with the measurements. The model is still under development at the Department of Mechanical Engineering but the preliminary results look promising for the future. Computational simulation models have been applied to predict and evaluate the local indoor climate in the benches. The performance of the local heating system has been compared to that of the conventional air heating system that was present in the church of Rocca Pietore. CFD (Computational Fluid Dynamics) simulations have been verified with the help of the measurement results obtained in the climate room set-up. After verification, these computer models have been used to perform a variant study to investigate the possible improvement of the thermal climate in the benches. In addition, the influence of the local radiant bench heating system on the indoor climate in the church of Rocca Pietore has been calculated.

1 Introduction

Nowadays many churches are equipped with a heating system. Most of them heat the whole indoor air volume. Operating those systems on a continuous basis requires high energy demands. For economic reasons, most churches are only periodically heated for the limited period in which people are present. This heating strategy can have an adverse effect on the preservation of the building and its interior objects. In addition, the churchgoers are often still not satisfied with the established comfort level in the pews.

This chapter will give an overview of the development of church heating, and explain the problems regarding the conservation of church buildings and their interior when an inappropriate heating strategy is used. The requirements for achieving thermal comfort will be discussed and a possible solution (local heating system) for these problems will be introduced. Finally, the research objectives of this research as well as the research questions and the outline of this thesis will be presented.

1.1 Development of church heating

For centuries, churches did not have a heating system except for a simple coal or peat stove which could be rented by churchgoers and placed near their feet. The church was not heated and, apart from the heat and moisture production from the people, the indoor air temperature and relative humidity were mainly affected by the seasonal changes of the outdoor climate. Nevertheless, the indoor climate seemed adequate for the preservation of interior works of art and the building itself.

In the nineteenth century, churches were equipped with one or more stoves which burned wood, coal and later oil, to heat the churchgoers. These stoves were hardly influencing the overall indoor climate. However, sitting close to the stove was too hot resulting in discomfort due to asymmetric radiation and, when seated too far away, the heat radiating from the stove no longer reached the people.

Besides, the heated air ascended directly above the stove. As from about 1920, central heating was introduced in churches and more damage to interior objects was reported. [Zanten 1995]. At first, the heating systems consisted of a central coal or oil burning boiler and heating pipes which transported the heat (by transporting hot water or steam) and were placed beneath the pews (kind of 'local' heating in the pews). In many Neo-Gothic churches, from about 1890 air heating was used as a central heating system.

After the Second World War the living standard of the people increased and the increased prosperity lead to higher comfort demands, not only in residential dwellings and office buildings, but also in churches. Many "local" heating systems were replaced by heating systems that heated the whole indoor air volume (e.g. air heating system, underfloor heating system) to a temperature of approximately 12°C. When cars became a common means of transportation, the comfort demands increased even more. Before, people used to walk to the church and were dressed to feel comfortable in the cold outdoor climate of winter, whereas now people travel by car which of course is heated. In this case, people may be dressed less appropriately for the outdoor climate since they are no longer exposed, at least not for long, to this cold environment. When people enter the church, they expect an indoor climate in which they will feel comfortable with their regular clothing. This means the indoor climate needed to be improved to create a higher comfort level. People were no longer satisfied with a temperature of 12°C in the church, therefore, the indoor temperature was increased to improve the comfort level. This comfort level depends on the habits of the congregation, therefore, it might differ per religiosity. For example, Roman Catholic churches were heated up to 15°C (people are dressed with their coat), whereas many Dutch Reformed churches were heated up to 20°C or more because those people take off their coat when they enter the church.

1.2 Risks regarding conservation

Heating monumental churches has never been easy. The church buildings are often large buildings with thick, massive walls and they are not well insulated. As mentioned in the previous section, many churches are equipped with a hot air heating system. If the air heating system is not implemented correctly and/or the heating strategy in the church is inaccurate, a variety of problems could occur. A temperature stratification could be introduced because the warm air that is blown into the church rises immediately towards the vault, whereas the region where the

people are, remains relatively cold. As a result, there could be problems regarding conservation, human thermal comfort, and a high energy consumption. The rapid heating of the indoor air, introduces abrupt changes in the indoor air temperature and relative humidity (RH). These changes could cause damage to the church building and to the works of art present inside. The rapid heating of the air, causes the relative humidity to drop. As a result, materials dehydrate, shrink and eventually crack. The abrupt change in temperature and relative humidity, introduces large gradients over the cross section of the object. Due to the moisture gradient, the surface layer will try to deform more than the underlying layers and internal stresses and strains develop. This can eventually lead to superficial micro- and/or macro-cracks or even cause the outer layer to detach from the underlying ones.

Not only the low relative humidity due to rapid heating of the indoor air causes problems regarding the conservation of the church building and its interior. Since churchgoers and visitors bring in moisture (rain and snow) and produce moisture by transpiration and respiration, the moisture content and therefore the dew point of the air is increased. The walls and other building parts which have large thermal inertia, are only heated slightly, and remain at a relatively low temperature which may be near the dew point temperature. As a result, the excess moisture in the air may condense on the cold surfaces of these objects.

The risk of condensation is also very high at the end of the service when the heating system is shut off, especially when there is no increased ventilation to lower the specific moisture content of the air. The air and the walls cool down and the RH increases. If the wall temperature drops below the dew point, there is the risk of condensation on these cold walls. Surface condensation can lead to a decay of the building material due to dissolution-recrystallisation cycles which occur in the stone and mortar [Arnold et al., 1991/1, 1991/2]. If walls are able to take up moisture, the problems regarding surface condensation are less critical [Padfield 1998], but research shows that RH cycles can also lead to a rapid decay of the building material [Lubelli 2006]. The combination of surface condensation and the temperature difference between the building structure and the indoor air increases the risk of deposition of dust and soot from candles on these cold, wet surfaces [Arendt 1993; Huynh et al. 1991; Schellen 2002]. As a result, these surfaces discolour. Also the risk of biological processes (growth of moulds and algae) on these surfaces increases when surface condensation or high RH occurs during a long period of time [Adan 1994; Sánchez-Moral et al. 1999].

Case studies all over Europe have shown that the problems outlined here, which are related to a wrong heating strategy, occur quite often. [Arendt 1993; Bordass 1984; Camuffo et al. 1995, 1998, 1999/1, 1991/2; Kozłowski 2000/1, 2000/2; Künzel et al. 1991; Pfeil 1975/1, 1975/2; Schellen 2002; Schmidt 1982; Stangier 1995]. Research on the relationship between the heating systems used in churches and the damage to the building and its interior, resulted in the establishment of criteria for the conservation of monumental objects [Knol 1971; Thomson 1978] and recommendations on the heating strategy in churches [Bordass 1984; Arendt 1993; Schellen 2002]. The criteria that are important for this present thesis are specified in table .

1.3 Local heating system

In the previous section, we have seen the problems which may result when heating the whole indoor air volume. Given what is known, it would be worthwhile to go back and investigate the possibilities of using a local heating system, since it may be the most safe method for the conservation of the church building and its interior objects. A local heating system should have less impact on the overall indoor climate in the church, but realize a higher comfort level for the people in the benches. Besides, the energy consumption should be lower because only the bench area (or even just a part of it) is heated. The performance of a local radiant heating system is investigated in this research.

There are several types of local bench heating systems, either operated by using hot water pipes or electricity. The heating systems which use hot water pipes require adjustments to be made to the building construction (walls, floor, etc.) in order to transport the hot water into the bench area. Besides, the hot water pipes have quite an aesthetic impact. The electrical systems require less adjustments to the building construction since only electric cables/wires have to be led to the bench area. The electric heating elements are mounted into the benches and provide the churchgoers with heat (based on convective, conductive or radiative heat transport or a combination of these).

When using a local heating system, special attention has to be paid to the risk of draught. Because only a small local region in the church is heated, draught could occur due to cold air that descends along the building structure. There are different methods to oppose draught. There are churches in which heat is provided at different heights to reduce the risk of draught. In other churches, blocks of benches are closed by small doors and/or panels around the benches.

There are even churches in which choir stalls are provided with side and back panels and a small wooden roof to prevent the cold air to enter the bench area. Small coal or peat stoves have been installed in the choir stalls to provide the people with warmth.

Another parameter which needs extra attention when applying a local heating system is the humidity of the air in the church. Introducing the heat in the benches might increase the evaporation of water (rain/snow) brought into the church by the people, thus increasing the water content of the indoor air. In addition, the local heating system does only heat the bench area and has only a very small influence on the overall indoor climate. Therefore, it is likely that the walls and other objects remain at a lower temperature than in the situation with a conventional heating system that heats the whole indoor air volume. This might increase the risk of a high relative humidity near the cold surfaces and even condensation on these surfaces, whereas it did not occur in the situation with the conventional heating system.

A solution might be to use the existing heating system to heat the whole indoor air volume to a primary temperature of approximately 10°C [Schellen 2002], and additionally, to use a local heating system to create the desired comfort level in the benches. In this way, the harmful, rapid changes in temperature and relative humidity due to the overall heating system disappear, and the constant primary temperature maintains higher surface temperatures of the walls and interior objects, thus decreasing the risk of surface condensation. As a result, the risk of damaging the building and its interior objects is decreased, while the required thermal comfort level in the benches is realized by the local heating system.

1.4 Human thermal comfort

Human thermal comfort plays an important role in judging the performance of heating systems. Thermal comfort exists when a thermal balance exists for the whole human body and simultaneously there is no local discomfort. Local discomfort occurs when the heat exchange between one or more body parts and its environment is very large compared to that of the rest of the body. Possible causes of local discomfort are: asymmetric radiation, draught and contact with cold surfaces (e.g. benches), which exist in a non-uniform environment.

A realistic goal for a church is that the human thermal state will be maintained “slightly cool” or “neutral” [Fanger 1970; McIntyre 1980] for the majority of the people in the church. Vigilance (paying attention and praying) is known to be

best when a person feels “slightly cool” [Enander 1987]. Also important is to obtain a thermal comfort level for the whole body by preventing a sensation of discomfort and draught. The age of the churchgoers has to be taken into account because thermo-regulatory responses of the elderly people are slightly different from those of other age groups [Young et al. 1997]. Not only the age, but also the gender, clothing and local traditions are important.

With the existing heating systems, satisfactory levels of thermal comfort might be reached by heating continuously. However, heating continuously is quite expensive and not justified for a few hours of service every week. Therefore, a local heating system that introduces the heat directly in the bench area and that will be used only during the service, might be a useful alternative. However, the use of a local heating system introduces a non-uniform thermal climate in the benches, which increases the risk of local discomfort. The situation could be rather uncomfortable for several reasons, i.e.: cold surfaces, hot and dry air, uneven distribution of the air temperature resulting, for example, in cold feet and a warm face, chilly flows of cool air (down draught) or other unpleasant effects. In addition, a low activity level during the services may also result in the cooling of the body.

1.5 European project

In March 2002, a European project called “Friendly Heating” was started to investigate whether a local heating system could meet both the criteria for conservation and for thermal comfort. In this project a local heating system was designed and its performance was tested. A “sound” local bench heating system can be defined as a heating system that meets both the criteria for conservation as well as those for thermal comfort. This is not easy, since we have seen that those criteria can be quite contradictory.

This PhD research started in June 2002 as part of the European project called “Friendly Heating”. Because of this, the measurements and simulations presented in this thesis are performed on the situation, geometry and the heating elements that were investigated within the EU project.

1.6 Research objectives

The objectives of this PhD research are:

- To investigate the performance of a local heating system with regard to the preservation of a monumental building and its interior objects, as well as with regard to the human thermal comfort.
- To investigate whether and how CFD (Computational Fluid Dynamics) can be used to evaluate and/or predict the (local) indoor climate. CFD is tested as a tool to calculate the (local) indoor climate around the church benches, as well as a design tool to reduce draught complaints by improving the lay-out of the bench region.

1.7 Research questions

The research questions are:

- Does a local radiant heating system perform better, with regard to the conservation of a monumental building and its interior, than a heating system which heats the whole indoor air volume?
- Is it possible to realize a local heating system that is safe for conservation and meets the desired level of human thermal comfort (i.e. 'slightly cool')?
- Can CFD be applied for performing a variant study, predicting the local indoor climate in and around the church benches?

1.8 Outline

The present chapter explained the basis for this research. Chapter 2 presents the European project “Friendly Heating” and the relation between the European project and this PhD research. The next two chapters will cover the measurements that are used to investigate the thermal performance of the local heating system (chapter 3) and the research regarding the human thermal comfort (chapter 4). Chapter 5 presents the results of the computational simulation models as well as a study of alternatives with help of CFD to investigate how the local thermal climate can be improved to increase the thermal comfort level. Finally, chapter 6 contains the general conclusions and recommendations of this PhD research, as well as recommendations for applying a local heating system.

2 EU-project “Friendly Heating”

2.1 Introduction

In March 2002 the “Friendly Heating” project was started as a research project within the 5th Framework Programme of the European Union. In this project, participants from different disciplines and countries were cooperating to search for a 'safe' heating system for monumental churches. The aim of this system was to meet both the criteria for conservation as well as the criteria for human thermal comfort. Our task within the European project was to create a computer model which allowed us to investigate and predict the local climate that originates from operating the local heating system in the benches.

As a case study in this European project, the church of St. Maria Maddalena in Rocca Pietore was used. Rocca Pietore is a small village in the Italian Dolomites with a relatively cold climate for Europe. Before the European project was started, an air heating system was operating in this church.

First, the original indoor climate (as a result of operating the air heating system) was investigated. This original situation formed the reference point for this project. In situ measurements were performed in order to determine the indoor climate resulting from the air heating system. Apart from these in situ measurements, which were performed by a partner within the European project [Camuffo et al. 2004], computer simulations were used to investigate the possible improvement (lowering air temperature and simultaneously increasing the inlet air velocity) of the old heating system.

During the first year, five pews were equipped with different prototypes of a local bench heating system. The local indoor climate resulting from operating this local heating system was investigated by measuring the indoor climate and the human thermal comfort. The thermal comfort was measured by performing a field survey (skin temperature measurements combined with questionnaires)

with local people. Also, a convocation with the local and national (Italian) authorities was held. The results from the measurements, and the discussions with the authorities lead to the choice of the most promising heating elements which were further developed and investigated in the last 2 years of the European project. All benches in the church were equipped with the (improved) local radiant heating system and the influence of this heating system on the indoor climate in the church was investigated (by measuring the indoor climate parameters and performing a field survey with local people similar to the survey performed in the first year) and compared with the reference situation. Also the reaction of the wooden sculptures of the altar to the 'new' indoor climate has been measured.

Computer simulations allowed us to calculate the overall and the local indoor climate in the church (air and surface temperatures as well as air flows). By means of these simulations a variant study has been performed to investigate further improvement of the local climate in and around the benches.

The local radiant bench heating system was investigated in one church, to investigate all advantages and disadvantages of this heating system. However, the heating system is based on general principles and could be applied to other churches and historical buildings. Special attention has to be paid to the adjustment of the heating system in order to meet the needs of other types of churches (e.g. churches without pews, with free areas etc.) or different types of church benches (e.g. choir stalls, benches and chairs).

2.2 Project organisation

As mentioned earlier, several research groups from different countries cooperated in this European project that was divided into several work packages. Figure 2.1 presents the project organization, that is, the work packages, the research institutes and the scientists that worked within these work packages. Each project partner contributed to the project from his/her research field.

2.2.1 WP1 Computer Simulations

Within this European project, we were responsible for the computer simulations (Work Package 1) to calculate and predict the effect of the local heating system on the local indoor climate of the church. Since every situation is different (e.g. a different church and/or heating system), it would be very expensive to build a

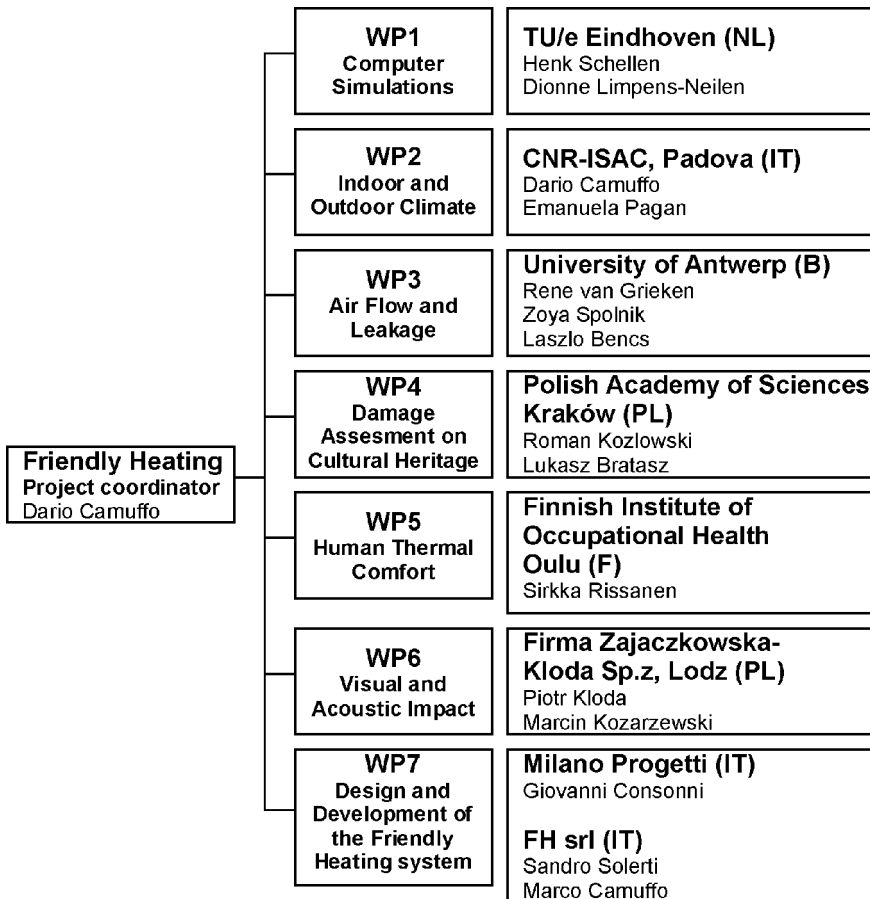

Figure 2.1. Overview work packages (partners) of the European project

mock-up for each situation. It would be ideal to have computer models which could be used to predict the influence of the heating system on the (local) indoor climate, e.g. the computer simulations would generalize the case study. Computer models have been used at different scale levels: a local and a global one. Computer simulations on the local scale allow the investigation of the local indoor climate in and around the church benches. Also, at this level the human thermal comfort and the design of local heating systems could be examined. The global scale is on the level of the whole building. Computer simulations have been used to investigate the effect of the local heating system on the overall indoor climate. Not only the performance of the heating system with regard to

the conservation of the building and its interior objects were investigated, but also the influence of the local air movement in the benches on the overall air movements in the church and vice versa.

To know whether the results from the computer simulations represent the actual situation in and around the church benches, a verification was performed with the help of measurements we conducted in a climate room. For the verification of the simulation results for the whole church, we used the measurement data derived from WP2 [Camuffo et al. 2006]. Within this research, the conservation of the building and its interior as well as human thermal comfort are very important. Therefore, with help of computer simulation programs we tried to investigate both.

2.2.2 WP2 Indoor and outdoor climate

Within this work package, long-term measurements on the outdoor and the indoor climate were performed by researchers from the Italian research institute CNR-ISAC [Camuffo et al. 2006]. As a result, the relation between outdoor and indoor climate, and the influence of both the air heating system and the local bench heating system on the indoor climate could be monitored. The air and surface temperatures as well as the relative humidity of the air were measured at 5 different heights in the front (behind the altar piece) and at the back (near the balcony) of the church. In addition, the general air velocity in the church was measured. During short-term measurements, the temperature stratification in the middle of the church was measured as well as the horizontal temperature profile near the wall. The measurements of the indoor climate were performed both for the air heating and the local heating system, see sections 2.5 and 2.8.1. The results of these measurements have been used either as input parameters (initial temperatures of the walls, indoor and inlet air, and the inlet air velocity) or to verify the computer model of the church (final values of temperatures and air velocities).

2.2.3 WP3 Air flow and leakage

Measurements on the indoor air quality and air movements in the church were performed by researchers from the University of Antwerp [Camuffo et al. 2006]. With the help of SF₆ tracer gas and a Bruel & Kjaer multi-gas monitor (Type 1302), the air exchange rate of the church was determined. The calculated air

exchange rate of the church in Rocca Pietore ($n= 0.22 \text{ h}^{-1}$), has been used as an input parameter for the computer simulations of the whole church.

The distribution and deposition of air pollutants on the artworks in the church is affected by the indoor air flow and air turbulence. These air pollutants could originate from indoor or outdoor sources, and appear in the gaseous or in the particulate phase. To investigate which type of pollution exists in the church, several measurement techniques were applied. Passive diffusion tubes were used to measure the most relevant **gaseous** air pollutants. These tubes were put up at several locations in the church and at different altitudes, and were exposed to the indoor climate for a certain time before they were analysed.

Pollution particles, either originating from the outdoor (e.g. soot) or indoor (e.g. smoke from candles and incense) can be easily transported by the indoor air flow. When deposited on the surface of the building or interior objects, they could chemically damage or stain paintings, fresco's, etc., depending on the particles' chemical and physical characteristics. Therefore, it was important to know the concentration and the nature of the airborne particles. This was measured using a single particle analysis technique; during 2 hours a certain amount of air was pumped through a set-up of several filters (from coarse to very fine) which collected the different sized particles that were present in the air. In the laboratory, these particles were counted and analysed using the Electron Probe Micro Analyses (EPMA) technique.

All measurements were performed before and after the installation of the local heating system. In this way, the effect of the local bench heating system on the indoor air flows and the conservation of the works of art was investigated.

2.2.4 WP4 Dimensional changes in wooden sculptures

The research group from the Polish Academy of Sciences performed measurements on the dimensional changes in the wooden sculptures of the monumental altar [Bratasz 2005/1; Bratasz 2005/2]. These measurements were performed with the original air heating system (rapidly heating the air before, followed by quick cooling after the service) and were repeated after the installation of the local heating system to verify the effect of the local heating system on the conservation of the wooden sculptures.



Figure 2.2. left: measurement set-up for measuring the dimensional changes of the wooden altar objects. Right: detailed view of measurement position 3, measuring the opening and closing of the crack in the head. (Photographs by Kozłowski / Kloda)

Non-contact electronic displacement transducers were used to monitor the dimensional changes of delicate wooden artefacts without any risk of damaging the objects' surfaces. Wooden elements of varying thickness were selected to investigate whether the influence of the changed indoor climate on these elements was different or not. These physical measurements were used to quantify the effect of the local heating system and indicate the risk of causing damage to these wooden objects. Figure 2.2. shows the measurement set-up which has been used to monitor the dimensional changes of various wooden objects: 1 = finger (very fine object), 2 = the Virgin's robe (large but thin object) and 3 = head (large massive object). In addition the opening and closing of a large crack in the wood was monitored (figure 2.2. photograph on the right).

2.2.5 WP5 Human thermal comfort

A scientist from the Finnish Institute of Occupational Health performed a physiological study to investigate the thermal sensation and thermal comfort of the people in the church before and after the installation of the local heating system. The human thermal state of the churchgoers was determined by measuring their skin temperature at 11 positions on their body during the whole service. Besides these measurements, the volunteers were asked to fill in questionnaires regarding the perceived thermal comfort and thermal sensation [ISO 10551, Fanger 1970]. The results from these measurements (presented in

section 2.8.2), were used to evaluate the performance of the local heating system with regard to the human thermal comfort. We performed similar measurements with volunteers in a climate room (see section 4.2) in order to validate a thermophysiological computer model.

2.2.6 WP6 Visual and acoustical impact

A group of restorers/conservators from Poland assessed the visual impact of the local heating system on the historic and aesthetic space of the church. Stylistic forms of the interior and the circumstances required for liturgy were primary factors to be considered and taken into account in the design of the heating system. Also parameters like ease of application and safety were assessed. The whole church, including the monumental interior objects, was modelled in a CAD (Computer Aided Design) program for visualising the aesthetic impact of the heating system on the perception of the interior.

2.2.7 WP7 Design and development of the local heating system

The design and development of the first prototypes of the local heating elements, were performed by the Italian company Milanoprogetti. They also provided the prototypes we tested in the climate room. This company was the partner for the European project and the firm FH, which actually designed and constructed the later prototypes as well as the final version of the local radiant bench heating system, was their subcontractor.

2.2.8 Stakeholder group

The European project has been supervised by a stakeholder group consisting of experts in different fields. The members of this group were present at the yearly meetings in Italy to oversee the development and progress of the European project. Moreover, the design and application of the heating system was performed in close contact with the art historians from the Ecclesiastic and Civil authorities, i.e. the *National Institute for the Cultural Heritage of the Church*, and by the Italian Ministry of Cultural Heritage for the conservation and the history of the Art.

2.3 Church of Rocca Pietore

2.3.1 History

The church in Rocca Pietore is a small church, which originates from the 15th century. It's a Gothic church that is built in the typical North Italian, late medieval style (one nave, short presbytery, open roof structure and cross vaults). In 1870 two lateral chapels were built. Due to the position between the mountains, the church is in the shade during the winter and does not receive direct radiation from the sun.

The outdoor walls, with a thickness of 0.7m, are made of local soft dolomitic limestone. The indoor faces of the walls are plastered. The glazing consists of stained glass, with an extra layer of glazing at the inside installed for comfort and energy reasons. Both the roof structure and the shingles that cover the roof consist of larch wood. Due to openings in the south and west wall of the attic, the attic has a direct connection with the outdoor climate. Therefore, the only construction separating the indoor from the outdoor climate is the vault which is made of porous travertine limestone and has a thickness of about 12cm. The indoor face of the vault is plastered. Figure 2.3 shows the church and its interior.

2.3.2 Valuable objects in the church

The interior of the church consists of several valuable wooden altars of which the main altar by Ruprecht Potech from Bressanone 1516-1517 is the most important one. This altar is typical for the region of northern Italy and its sculptures and canvas paintings originate from the 16th and 17th century. The indoor face of the vault has mural paintings originating from the 15th and 20th century. The choir in the back of the church has a decorated wooden balustrade.



Figure 2.3. From left to right: the Church of Rocca Pietore, the main altar, the paintings on the vault, the decorated wooden balustrade of the choir in the back of the church

2.4 Heating system

The original heating system in the church of Rocca Pietore is an air heating system, with a heating capacity of 85kW. The heating system is not controlled and runs at maximum capacity when switched on. It has two inlet grills (dimensions $0.6*0.6\text{m}^2$) positioned at a height of 4m, one in the main nave and one in the transept. There is one return grill (dimensions $1.0*1.0\text{m}^2$), positioned in the floor of the transept, below the inlet grill, see figure 2.4. The air is blown into the church with a temperature of about 70°C and a velocity of about 1.5m/s , thus reaching an Archimedes number of 0.66 [-]. For the explanation of the Archimedes number, see Appendix A.

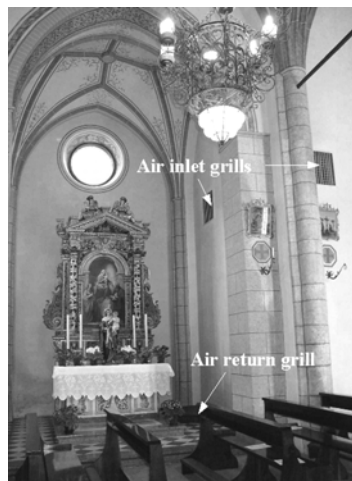

Figure 2.4. Air inlet grills and the return grill of the air heating system in the church of Rocca Pietore

2.5 Problem description

During winter, the indoor air in the church reaches an average temperature of about 6°C . In order to heat the church for the services, the air heating system was operated for several hours (from 2 hours before the start of the service until the end of the service). Figure 2.5 demonstrates the measured air temperature and relative humidity near the altar piece, at 5 positions over the height of the church. It shows that, to obtain a comfortable temperature for the people in the church benches, the air in the church was heated rapidly, thus introducing abrupt variations in temperature and more important in relative humidity.

As a result of these variations, the hygroscopic moisture content in the materials changes which induces the shrinking and/or swelling of the materials. This could cause damage to the interior objects as well as the building itself. Apart from causing damage, operating the air heating system for a few hours results in relatively high energy costs, because the whole indoor air volume is heated.

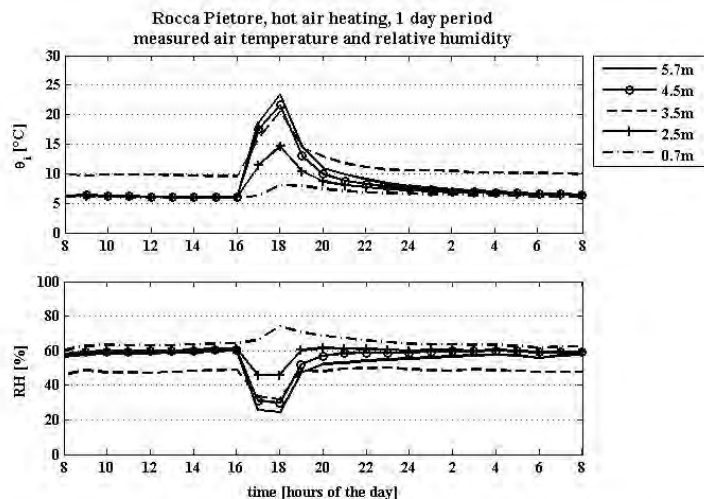

Figure 2.5. Air temperature and relative humidity measured in the church of Rocca Pietore when operating the original, hot air heating system

2.6 Methodology

Based on the knowledge that a smaller Archimedes number results in a smaller temperature stratification in the church [Schellen 2002], simulations have been made to see whether adjustments to the original heating system could be a possible solution for the church in Rocca Pietore. The Archimedes number could be decreased by increasing the air supply velocity at the inlet (u_0) and/or lowering the supply air temperature which would decrease the temperature difference between the supply air and the indoor air ($\Delta\theta_0$).

From the viewpoint of conservation, the temperature difference between the inlet air and the indoor air should not exceed 25°C [Schellen 2002]. In addition, the heating rate of the indoor air should be limited to 2K/h , and the temperature stratification over the height of the church to 0.1K/m (see table 2.1:).

Table 2.1: Criteria for the conservation of monumental churches and their interior [Schellen 2002]

Property	Symbol	Unit	Lower value	Upper value
Relative humidity mean	RH_{mean}	%	45	75
Relative humidity short term	RH_{short}	%	40*	90
Yearly change RH	ΔRH_{year}	%		30
Daily change RH	ΔRH_{day}	%		10
Heating rate	$\Delta\theta / \Delta t$	K/h		2
Temperature stratification	$\Delta\theta / \Delta h$	K/m		0.1
	$\Delta\theta_{\text{max}}$	K		2**
Indoor air velocity in comfort area	u	m/s		0.15
<i>Additional in case of an air heating system:</i>				
Supply air temperature	$\theta_{\text{a,supply}}$	°C		$\theta_i + 25$
Length of throw	l_{max}	m		$2/3 l_{\text{object}}$
Supply air velocity	u_0	m/s	$Ar < 0.05$	from l_{max}

* Limited by a hygrostatic device

** Over the height of the church

In the case of Rocca Pietore this means that the maximum allowed air supply temperature is about 31°C. To reach the same heating capacity, the air velocity near the inlet should be 3.9m/s. This results in an Archimedes number of 0.04 [-] whereas the original Archimedes number was 0.66 [-].

Figure 2.6 demonstrates the temperature stratification of the existing situation in the church ($\theta_{\text{a,supply}} = 70^\circ\text{C}$, $u_0 = 1.5\text{m/s} \rightarrow Ar = 0.66$) and the situation in which the heating system is modified ($\theta_{\text{a,supply}} = 31^\circ\text{C}$, $u_0 = 3.9\text{m/s} \rightarrow Ar = 0.04$). It shows that the temperature stratification in the modified situation is reduced from about 1K/m to 0.4K/m (over the height of the church).

If the air heating system would be adjusted to the situation explained before (lower supply air temperature in combination with a higher air supply velocity), it would be safer for the conservation of the historical objects and the church building, but still exceed the criteria specified for conservation. Besides, a lot of warm air rises to the vault instead of remaining in the bench area where it is needed. So from the efficiency viewpoint, it still is not perfect. In addition, one should be cautious in order to avoid creating too large air velocities in the comfort zone. Too large air velocities could lead to complaints about draught.

Therefore, to increase the air velocity without risk on comfort problems due to air draught, the church should have been wider and the air should be supplied at a sufficient height above the comfort zone.

To find a solution in which all factors are taken into account, a new heating system was designed within the European project. This heating system is a local radiant heating system mounted into the benches in order to provide the heat where it is needed. Because the heating system has mainly radiant properties, convection should be minimized and most of the warmth should stay in the bench area instead of rising to the ceiling. There would be no abrupt changes in temperature and relative humidity in the church, because the overall indoor climate would not be affected by the local heating system. This appears to be a sound solution for the conservation problem. The performance of the heating systems with regard to the conservation of the interior objects in the church has been investigated by monitoring the dimensional changes of the wooden sculptures in the main altar piece (as explained in section 2.2.4).

Because the local heating system would be operated just during the service (with only a pre-heating period of 15 minutes instead of 2 hours), it would also save energy. Besides, since only the people in the benches have to be heated instead of the whole indoor air volume, the heating capacity of the local heating system could be much smaller than that of the existing air heating system. With regard to the human thermal comfort, people would receive the heat directly from the heating element by radiation. Asymmetric radiation, cold building surfaces (the walls would not be heated by the heating system), and cold air temperatures could possibly create a thermally uncomfortable situation for the people in the benches. Therefore the thermal comfort had to be investigated by measuring the thermal state of the body, and asking people to rate their thermal state and thermal comfort level by filling in questionnaires during the service.

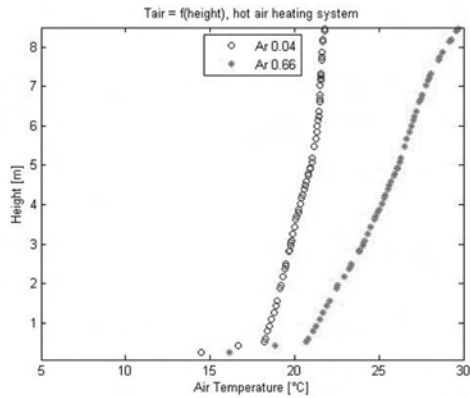

Figure 2.6. Simulation results of the temperature stratification in the middle of the church. Original ($Ar=0.66$) & modified ($Ar=0.04$) heating system configuration

2.7 Local radiant bench heating system

The main goal of the local radiant bench system designed and tested within this research project, is to provide heat only in the benches, that is, where it is needed to create a comfortable local climate for the people. The system consists of 3 different heating elements, based on radiant heating foil. The first element is placed underneath the seat, the second element (hand heater) is placed in the wooden back and the third element is placed underneath the kneeler pad. These elements radiate the heat to the people directly instead of heating the air and/or the benches first. The heating capacity of the local radiant heating system (25kW) is much lower than that of the original (air) heating system (85kW). Because of the radiant feature, the heating system only has to be operated during the service (about 1 hour) instead of 3 hours in the case of the air heating system. This should result in much lower energy consumption (see table 2.2). Whether it also results in lower energy costs, depends on the prices of electricity and gas or oil, which might be different per country/region.

Table 2.2: Energy consumption in the church for one service

	Heating capacity [kW]	Operating time [h]	Energy consumption [kWh]
Air heating system	85	3	255
Local radiant heating system	25	1	25

2.7.1 System configuration

The local heating system consists of the three elements specified in the next sections. Figure 2.7 shows the position of the heating elements in the church bench. The elements consist of an electrical heating foil of the brand Thermotex. This foil consists of glass fabrics that are impregnated with electrical conducting plastics "PTFE-Carbon". Tin plated copper foils are stitched to the edges of the heating foil as bus bars. The electrical insulation is obtained by laminating a compound of polyester/polyethylene foils. The power supply of the heating foil is 220V which results in a foil temperature of about 60°C. The electrical wires are concealed in gutters that are placed underneath the wooden floorboard. As the heating power per bench is 880W, this results in a total heating power of 25kW for the whole church (whereas the existing air heating capacity is 85kW).

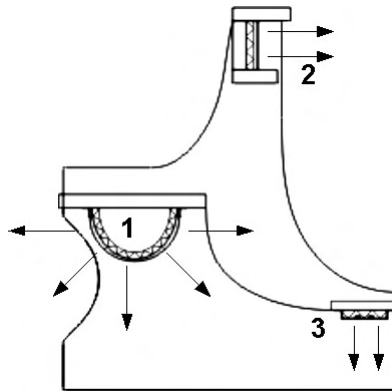

Figure 2.7. Overview of the heating elements that were applied in the bench

2.7.2 Seat heating element

The heating element applied under the seat of the pews (figure 2.7, element 1) is a semicircular element with a length of 99cm and a radius of 11cm. The element has a load of 155W and is designed to radiate heat to people's legs. Two of these elements are applied per length of the bench.

In order to prevent overheating the seat, which can cause the wood to crack, thermal insulation is applied behind the heating foil. So the heat is only radiated to the floor and the front and back of the bench. In order to protect the heating

foil, it is covered with a perforated metal grid that is kept at a distance of 1 cm from the foil with the help of spacers. The perforation rate of the metal grid is 50% which means that most of the IR radiation from the heating foil can reach the people directly. The maximum temperature of this grid is 35°C, thus preventing people to burn their skin or clothes when touching the heating element.

2.7.3 Hand heating element

The dimensions ($l \times w \times h$) of the hand heating element (figure 2.7, element 2) are $200 \times 2 \times 13 \text{ cm}^3$ and its electrical load is 290W. In this element, the heating foil is covered with the metal grid mentioned earlier. The metal grid in this heating element is also kept at a distance of 1 cm from the foil using spacers. The heating element is attached in the wooden back of the seat and radiates the heat to the front of the people that are sitting in the back seat.

2.7.4 Kneeler pad element

The dimensions of the heating element which is located underneath the kneeler pad (figure 2.7, element 3) are $195 \times 13 \times 2 \text{ cm}^3$ ($l \times w \times h$) and its electrical load is 280W. To prevent overheating the kneeler pad, which can damage the wood, insulation is applied between the heating foil and the kneeler pad. The combined layer of insulation and heating foil is covered with a metal sheet. This sheet is heated and then radiates to the wooden floorboard and to the people's feet that are placed beneath this kneeler pad.

Table 2.3: Specifications of the heating elements

Heating element	Shape	Protective cover of the element	Heat source	Length [m]	Width [m]	Height [m]	Electrical Power [W]	# per pew
Seat	semicircular	metal grid, 50% open	Electrical heating foil	0.99	Radius = 0.11		155	2
Hand	rectangular	metal grid, 50% open	Electrical heating foil	2.00	0.02	0.13	290	1
Kneeler pad	rectangular	metal sheet	Electrical heating foil	1.95	0.13	0.02	280	1

2.8 Results

2.8.1 Conservation

Figure 2.8. shows the indoor air temperature and relative humidity measured within work package 1 of the European project. From these measurements, we can conclude that the local heating system does not influence the indoor climate of the church as much as the air heating system (compare figure 2.5 and figure 2.8.). The local heating system increases the indoor air temperature in the church by 3°C to 4°C and does not introduce abrupt changes in the temperature or relative humidity. Also, there is no temperature stratification over the height of the church any more. Although the surface temperature of the walls remains lower with this local heating system than with the air heating system, no signs of surface condensation have been noticed in the church.

The absence of abrupt changes in temperature and relative humidity also reduced the dimensional changes in the wooden objects [Bratasz 2005/1]. The measured dimensional changes [%] of the crack in the wooden head of the altar (see figure 2.2.) are presented in figure 2.9.. It shows the air temperature, relative humidity of the air, and the dimensional change of the crack in the wooden head as a result of operating the original air heating system (left) and the local bench heating system (right). In the situation with the original air heating system, the dimension of the crack (which is caused by changes in the relative humidity of the air) keeps changing during each heating period. In the situation with the local heating system, the changes in temperature and relative humidity are much less, and also the dimension of the crack is more stable. From these measurements, that were conducted by the Polish project partners, we can conclude that the local heating system is much safer for the historical works of art than the air heating system.

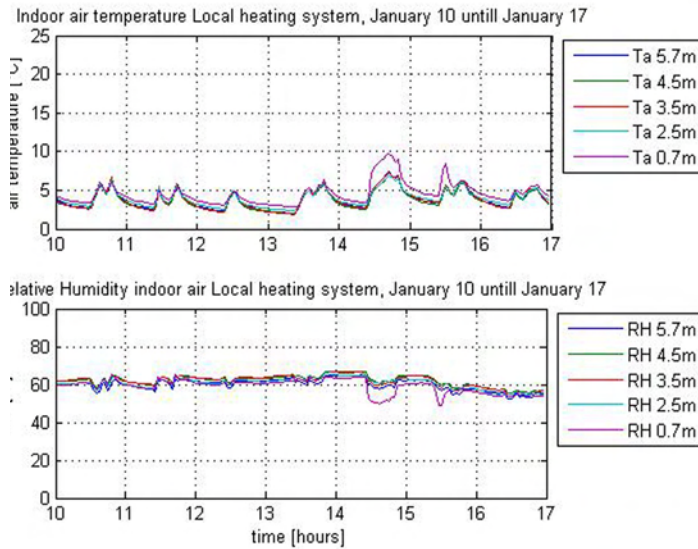

Figure 2.8. Air temperature and relative humidity measured in the church of Rocca Pietore when operating the local heating system

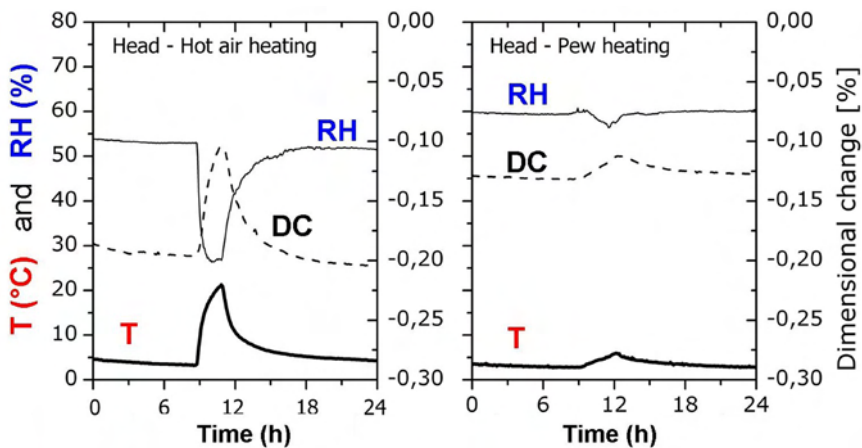

Figure 2.9. Measured air temperature, relative humidity and dimensional changes in the wooden altar object (head) as a result of operating the air heating system (left) and the local heating system (right). (Graphs created by Kozłowski)

2.8.2 Human thermal comfort

The human thermal comfort in the church was investigated by a scientist of the Finnish Institute of Occupational Health. The results from the skin temperature measurements and the questionnaires surveys show, that the churchgoers from Rocca Pietore are more pleased with the local heating system than they were in the situation with the air heating system [Camuffo et al. 2006]. Figure 2.10. shows the ratings of the thermal sensation and the human thermal comfort in 3 situations: a) the air heating system, b) the first prototype of the local radiant bench heating system, and c) the final version of the local radiant bench heating system. Both thermal sensation and thermal comfort show a **decrease in difference between body parts**. The volunteers experience the thermal state and thermal comfort of the whole body more homogeneously. The figure clearly shows an increase in human thermal comfort, and the **aimed thermal sensation level between ‘neutral’ and ‘slightly cool’ is achieved**.

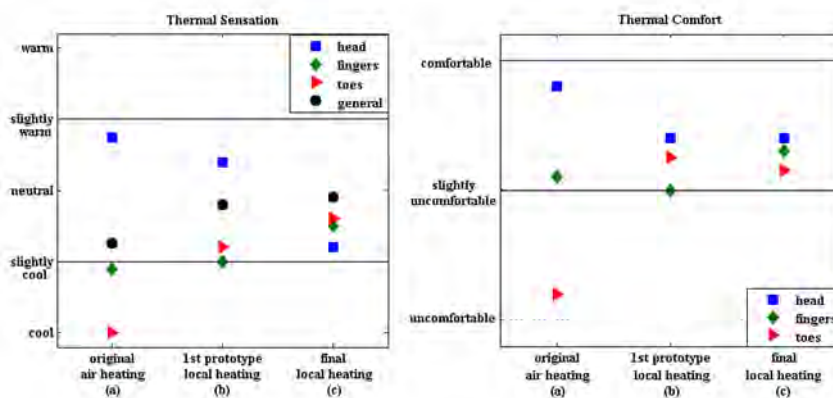

Figure 2.10. Thermal sensation (left) and thermal comfort (right) rated by the human volunteers in the church of Rocca Pietore; a) air heating system, b) 1st prototype local heating and c) final version of the local heating system (graphs according to the results of Rissanen)

2.9 Conclusions

Within the European project Friendly Heating, a local heating system has been tested to investigate whether it would be a better alternative for heating churches than the conventional (in this case an air) heating system. According to the measurements that were performed, it seems to be a safer heating system regarding the conservation of the monumental interior and the church building itself. The local heating system had less impact on the overall indoor climate, and the dimensional changes of the wooden objects were reduced to such an extent that the risk of damaging the building and its interior objects is minimized. In the church in Rocca Pietore, the local heating system is used to heat the bench area. Only when it is very cold in the church, the original air heating system is shortly used to preheat the church and increase the indoor air temperature by a few degrees.

In this church, the moisture level had never been a problem. No traces of long-term high relative humidity near, or condensation on cold surfaces has been recorded. For this church, the local heating system performed quite well. But, in churches with another geometry and different materials used, as well as churches under different climatic circumstances, the moisture level in the church needs to be taken into account to avoid potential problems due to surface condensation.

Also the human thermal comfort level was increased although the people still had some complaints about draught around their neck and ankles when seated in certain locations in the church. Therefore, this PhD thesis (see chapter 5) presents a variant study performed to investigate how the local climate in and around the benches could be improved in order to prevent people from feeling local discomfort due to draught.

3

Experimental set-up

3.1 Introduction

One of the goals of the research described in this thesis is to investigate whether it is possible to predict the effect of the heating elements on the local indoor climate in the benches, with help of computer simulations (and not to choose the best performing heating element). Without verifying the simulation results with actual measurements, one does not know whether the simulations of the climate around the benches represent the real situation or not. Therefore, the first sections of this chapter present the measurements that were used for the verification of the simulation model. In the second part of this chapter, the resulting local climate in the benches is evaluated regarding human thermal comfort.

3.2 Configuration climate room set-up

Because the real situation in the church is very complex due to non-stationary (i.e. time and place dependent) air flows, a proper investigation of the local climate as a result of **different local heating elements** is not possible in this situation. Therefore, research on that was performed in a well defined, steady state situation, so that each type of heating element was tested in the same environment. This steady state situation was created in a climate room at the Eindhoven University of Technology. The room boundaries of this room (walls, floor and ceiling) could be controlled around a specific temperature. The dimensions ($l \times w \times h$) of the climate room are $9.7 \times 5.2 \times 2.7\text{m}^3$, see figure 3.1.

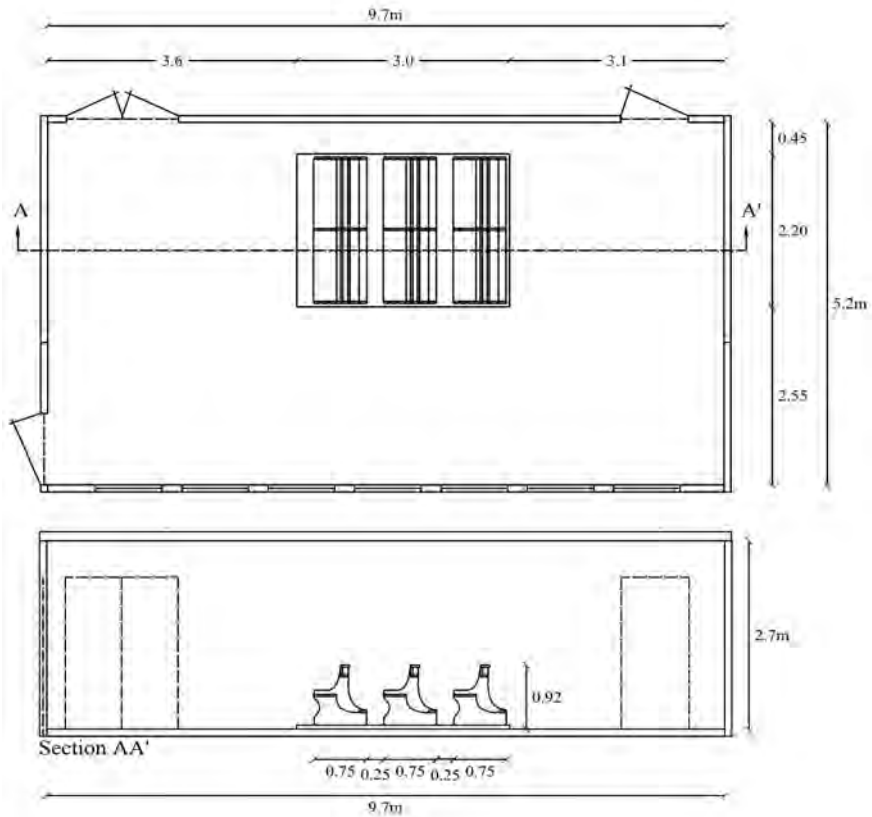

Figure 3.1. Configuration of the climate room with benches. Top: floor plan, bottom: longitudinal section

In this climate room, a measurement set-up has been built around three church benches equipped with the local heating elements. The benches were placed on a wooden floorboard and at a distance of 0.5m from the wall, which was the same as in the church in Rocca Pietore.

3.3 Local heating system

Within the European project, several prototypes of local heating elements were installed and tested in the church in Rocca Pietore, Italy (see section 2.6). The first three prototypes were also applied in the benches in the climate room (see figure 3.2.). Of those prototypes, the seat heating element is still as such applied in the church. The other prototypes were either replaced by a different element

(back heating replaced by hand heating) or improved (kneeler pad element). Table 3.1 presents the specifications of the heating elements that were tested in the climate room. They were based on two different types of electrical heat sources: heating foil and resistance cables.

The heating foil of the brand Thermotex (for details, see section 2.6) was used in the elements which were placed in the back and under the seat of the bench. The electrical resistance wire (Raychem Electromelt EM2-R, length 4m) was applied in the heating element mounted under the kneeler pad. The surface temperatures of the three different heating elements as a function of time are presented in figure 3.3.

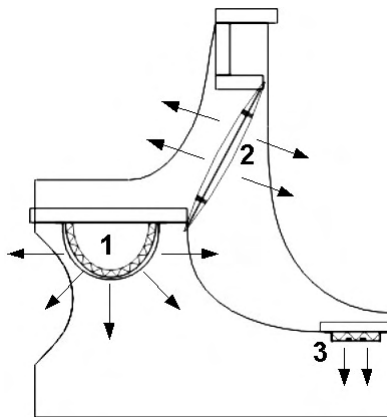

Figure 3.2. Heating elements tested in the climate room set-up

3.3.1 Seat heating element

The heating element that was applied under the seat of the pews (figure 3.2., element 1) was a semicircular element with a length of 99cm and a radius of 11cm. Two heating elements, each with a load of 155W, were applied in one pew. The element was designed to radiate heat to the people's legs. In order to prevent overheating the seat, which could cause the wood to crack, thermal insulation was applied behind the heating foil. As a result, the heat was only radiated to the floor and the front and back of the bench. In order to protect the heating foil from mechanical damage, it was covered with a perforated metal grid. This grid was kept at a distance of 1 cm from the foil with help of spacers. The perforation rate of the metal grid was 50% so the IR radiation from the heating foil could reach the people directly.

3.3.2 Back heating element

The dimensions of the back heating element (figure 3.2., element 2) were $200 \times 2 \times 35 \text{ cm}^3$ ($l \times w \times h$) and its electrical load was 370W. In this element, the heating foil was covered on both sides (back and front) with the same metal grid as was applied in the seat heating element. The metal grid in this heating element was also kept at a distance of 1 cm from the foil using spacers. The heating element was attached between the back and the seat; in fact it closed the back of the bench which was originally open.

3.3.3 Kneeler pad heating element

The heating element applied underneath the kneeler pad (figure 3.2., element 3) consisted of a resistance wire that was double folded. The resistance of the wire increased when the temperature of the wire increased. Therefore, the heating element had a peak load of 970W right after the power was switched on, and decreased to 130W after about 3 minutes when the equilibrium temperature was reached. Also in this heating element, thermal insulation was applied to prevent overheating (and damaging) the wooden kneeler pad. The insulation was applied between the electrical resistance wire and the kneeler pad. The combination of insulation and heating wire was covered with a metal sheet. This sheet was heated and then radiated to the wooden floorboard and to the people's feet placed beneath the kneeler pad.

Table 3.1: Specifications of the heating elements tested in the climate room

Position	Shape	Protective cover of the element	Heat source	Length [m]	Width [m]	Height [m]	Electrical Power [W]	# per pew
seat	semicircular	metal grid, 50% open	Electrical foil	0.99	Radius = 0.11		155	2
back	rectangular	metal grid, 50% open	Electrical foil	2.00	0.02	0.35	370	1
kneeler pad	rectangular	metal sheet	Electrical Resistance wire	2.00	0.09	0.02	130 (start peak 970W)	1

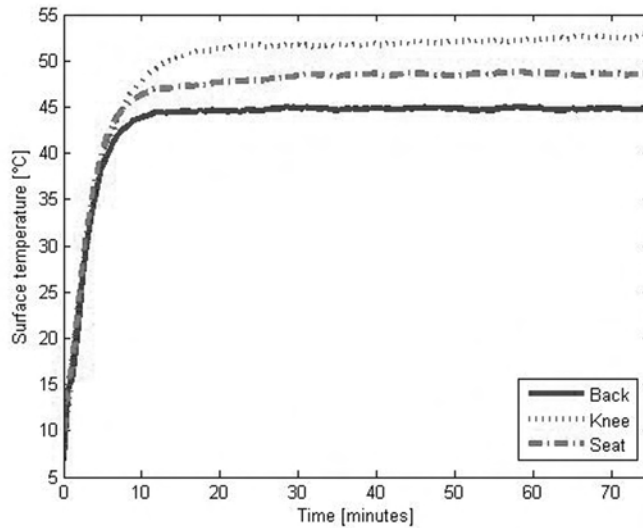

Figure 3.3. Surface temperature of the heating elements as a function of time

3.4 Measurement set-up

The measurements that were performed to investigate the influence of the heating elements on the local climate in the benches were taken in two different situations: a) in the benches without people and b) with a thermal manikin that represented a person as a heat source. The results of the first measurement situation were used to verify the CFD results. The second measurement situation was used to investigate the effect of the heating element on the surface temperature of the manikins clothing (using IR thermography) and the influence of the manikin on the air flow in the benches (by means of smoke tests).

Both **qualitative** measurements and **quantitative** measurements were performed to investigate the local climate in and around the benches. The qualitative measurements consist of visualizations by infra-red thermography (temperature distribution), and smoke tests (air flow pattern in a vertical 2D plane between the benches). The quantitative measurements were performed by measuring air (θ_a), surface (θ_s) and radiant temperature (θ_r), air velocity (u_a) and turbulence intensity (TI) with sensors placed at different locations in the bench area. Table 3.2 gives an overview of the measurements that were performed in this research.

Table 3.2: Overview measurements and their purpose (V = verification of CFD, T = thermal comfort)

	Manikin/person seated in bench	Visualization		Measurement			
		Infra red	Smoke test	θ_a, θ_s	θ_r	u_a	TI
Seat heating	no	V/T	V/T	V/T	V/T	V/T	V/T
	yes	T	T	T	T	T	T
Back heating	no	T	T	T	T	T	T
	yes	T	T	T	T	T	T
Kneeler pad heating	no	T	T	T	T	T	T
	yes	T	T	T	T	T	T
Variant study with front and side panels to close the bench area	no	V/T	V/T	V/T	V/T	V/T	V/T

3.4.1 Manikin representing a person in the benches

A former PhD at the TU/e designed a manikin which represents the heat production of a human being in an office environment [Loomans 1997]. The manikin consists of six body segments: head, trunk, left leg, right leg, left arm and right arm. Each segment contains one or two light bulbs for the heat production as well as one or two fans. These fans, which operate on 12V, always run on full power and distribute the heat evenly within the body segment by mixing the internal air. The light bulbs are provided with dimmers so the power can be adjusted for each body segment.

The manikin designed by Loomans, is also applied in the climate room set-up in order to investigate the influence of the various heating elements on a human being. The clothing level of churchgoers during winter is greater than that of people in an office environment. Therefore, the clothing level of the manikin was adjusted to winter clothing, and the produced heat, the shape of the manikin and the ratio between heat exchange due to radiation and convection were matched with reality. Figure 3.4 presents an infra-red thermographic picture which shows the resemblance in outer surface temperature of the manikin and a human being. On the basis of thermographic pictures of the manikin it is possible to evaluate which body parts are heated by the heating elements. In the next sections these results are presented for each separately operated heating element.

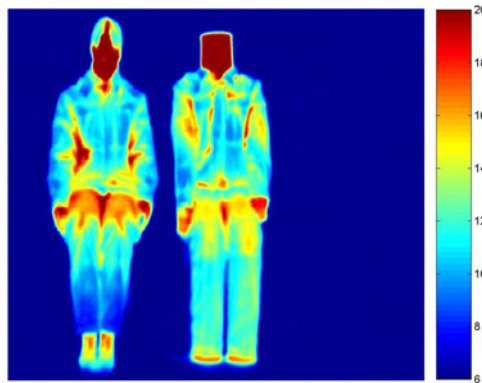

Figure 3.4. Verification of the heat production of the manikin (right) with that of a human being (left), both dressed in winter clothing

3.5 Measurement equipment

3.5.1 Infra-red thermography

Infra-red thermography is an appropriate method to measure surface temperatures, but not for measuring air temperatures. Because an impression of the geometric 2D distribution of the air and surface temperatures was desired, paper strips were fixed to the ceiling. These strips enabled us to measure the 2D temperature distribution of the paper by means of infra-red thermography. This temperature represents a combination of the local air temperature and the radiant temperature. Due to its low heat capacity, the temperature of the paper responds relatively fast to the surrounding air temperature, and therefore paper is suitable for this measurement. Paper strips instead of a paper sheet were used to avoid too much disturbance of the air movement. The infra-red thermography was performed with an IR camera (Jenoptik Varioscans, type LW2011) that was connected to a laptop on which the accompanying software was installed.

3.5.2 Smoke tests

Different kinds of smoke tests were performed in the climate room measurement set-up. For the measurements performed in 2003 and 2004, a smoke generator (Mini Fogger, type 60619) and a digital video camera were used to visualize and record the air flow. These video recordings gave a good indication of the air

flows in and around the benches. The smoke was released just above the wooden floorboard in the front of the first bench and behind the third bench. However, this set-up was not suitable for the measurements of the variant study (presented in section 5.2.3) which was performed in 2005. Since the air flow was only recorded from one camera position, the panels that closed the benches at the front and at the sides formed a barrier, and the air flows between the benches could not be recorded properly. Therefore, in this variant study the smoke tests were recorded using a set-up that consisted of four web cams (Logitech 4000pro) positioned at different locations. These web cams were connected to a laptop on which the software “Active Webcam” was installed. This program was able to record the video streams from the web cams simultaneously. This allowed us to stay at a suitable distance from the measurement set-up and not disturb the air flow in the benches. The panels also prevented the use of the smoke generator. Therefore, smoke tubes (Dräger, air flow testers, type 4351) were used to visualize the air flows.

3.5.3 Temperature measurements

The air temperature was measured at 16 positions on a measuring grid (see figure 3.5) using Negative Temperature Coefficient (NTC) sensors. The surface temperature was measured at 24 positions, also using NTCs. Squirrel data loggers (Grant 1200, type 1204 and Grant 1600) were applied to register the output of these sensors. The positions of the temperature sensors as well as the air velocity sensors were determined based on these temperature measurements combined with the positions that were relevant for determining the thermal comfort of a seated person. Furthermore, all NTCs were positioned in such a way that the influence of direct radiation from the heating elements was minimized. All temperature sensors were calibrated for climatic conditions ranging from 0°C to 60°C according to the reference principle. This calibration was performed in a small climate cabinet (Weiss). All laboratory measurements presented in this thesis were performed with these calibrated sensors.

3.5.4 Air velocity measurements

The air velocities and turbulence intensities were measured using eight hot sphere anemometers (Low velocity Transducer 54R10, Dantec). The anemometers were connected to a configuration of a 3-channel Input Module

(54N21, Dantec), an A/D converter (data shuttle, Strawberry Tree) and a laptop. This allowed us to store the bridge voltage output for all anemometers with a simultaneous 10Hz sampling frequency. The hot sphere anemometers were calibrated using the calibration method described by Loomans [Loomans 1996]. The anemometers were placed at the 8 most important positions determined on the basis of the performed smoke tests.

3.6 Measurement procedure

3.6.1 Local climate

At first, infra-red thermographic pictures were taken to visualize the temperature distribution, and smoke tests were performed to visualize the airflow in and around the church benches. Those two kinds of measurements gave a first global impression of the influence of the local heating system on the temperature distribution and the air movements in and around the benches.

For each heating system, the measurements on the local climate were performed at different locations in a vertical plane cut. If people would be seated on the church bench, the plane cut would be located between the first and second person, counting from the wall side. A measuring grid was applied to this plane cut that was positioned at a quarter of the church bench (52.5cm from the side of the bench) see figure 3.5. The white crosses indicate the positions at which the sensors were fixed. The local climate in front of the first bench and behind the third bench differs from the general local climate due to side effects. Therefore, all measurements were performed around the middle bench.

For the measurements investigating the effect on thermal comfort, the manikin was placed on the middle bench at the second position from the wall side (to the left of the measuring grid) as shown in figure 3.5.

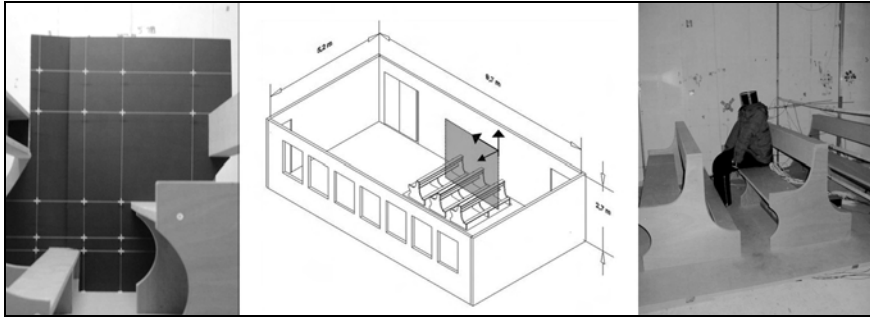

Figure 3.5. Measuring grid applied between the benches (left), position of the measurement plane (middle) and position of manikin (right)

3.6.2 Boundary conditions

The idea was to create an indoor climate in the climate room that represented the average indoor climate ($\theta_{\text{average}} \approx 4^{\circ}\text{C}$ to 5°C) of the church of Rocca Pietore (Dolomites, northern Italy) during winter. Since the measurements in the climate room would not only be performed during winter, but during the whole year, the performance of the climate room had to be taken into account. A temperature of 6°C was about the lowest temperature expected to be feasible during the whole year. Therefore, the boundaries (walls, ceiling and floor) of the climate room were controlled at a temperature of around 6°C during all measurements.

3.6.3 Measurement time

All the measurements that were performed in the climate room lasted for at least 90 minutes. During the first 15 minutes, the actual situation in the climate room was recorded to verify the boundary conditions of the room. After that, the heating elements were turned on for 75 minutes: it took about 10 to 15 minutes for the system to heat up and then the measurements went on for 60 minutes, which is about the duration of a service in the church. Finally, the heating elements were switched off and there was a period in which the whole measurement set-up had to cool down to its initial temperature. Depending on the length of this cooling down period, it was possible to perform one or two measurement sessions a day.

3.7 Measurement results

Table 3.3: presents the quantitative results that were measured at the different sensor positions in the plane cut. The regions that were most affected by a heating element are marked grey, to allow a quick comparison between the heating elements. The air temperature, air velocity and turbulence intensity are presented in three regions: 'low' is the region lower than the seat of the bench (around the people's **legs and feet**), 'mid' is the region between the seat and the back of the bench (around the **bottom and torso**) and 'high' represents the region above the back of the bench (**shoulder and neck area**). Smoke test showed that for all heating configurations, the main (cold) air flow entered the benches from the front and ascended right above the second bench. Secondary flows of cold air entered the bench area from the side of the benches, right above the wooden floorboard.

Table 3.3: Overview of quantitative measurement results, initial temperature=6.4°C. The regions that were most affected by a heating element are marked grey

	Position of the operating heating element		
	Seat	Back	Kneeler pad
Surface temperature [°C]			
Heating element	35	35.2	55
Back (front)	9.3	17.8 – 20.1	6.7
Seat (top)	12.7 – 15.9	10.8 – 11.6	6.5
Kneeler pad	9.1	9.2	9.2 - 15.7
Floorboard	9.3 – 11.3	7.5 - 8.3	8.7 - 11.7
Air temperature [°C]			
High (>96cm)	9.8	8.7 – 9.3	7.5
Mid (50 – 96cm)	10.3	8.9 – 10.4	7.7
Low (< 50cm)	8.7 – 9.4	8.2 - 8.5	8.1
Mean air velocity [m/s]			
High (>96cm)	0.19	0.08	< 0.05
Mid (50 – 96cm)	0.17	0.05	0.05
Low (< 50cm)	0.04	0.05	0.08
Turbulence Intensity [%]			
	15–75min	15–75min	15–75min
High (>96cm)	35	35	44
Mid (50 – 96cm)	53	31	23
Low (< 50cm)	50	22	34

3.7.1 Seat heating element

Before the heating element was turned on, the air velocity for all measurement positions was 0.05m/s or less. The measurements showed that switching on the heating system resulted in a rising air flow at the front and the back of the seat, introducing turbulence right above it. The largest mean air velocities (0.2m/s to 0.36m/s) were measured at shoulder height. Furthermore, the air movements seemed to be more turbulent between the benches than above them.

Figure 3.6 (left) presents an IR thermographic picture of the situation in which the heating element under the seat is operated. It shows that the area between the benches was heated by this element. Figure 3.6 (right) presents a picture from the smoke tests. The arrows indicate the air flow between the benches as it was visible in the video film.

Whereas the heating foil in this element reached a temperature of 50°C, which is too hot for touching, the metal grid that covers the foil reached a surface temperature of 30°C, which is safe. As a result of operating this heating element, the surface temperatures of the kneeler pad and the back of the pew increased about 3°C. Due to radiation from the heating element, the surface temperature of the wooden floorboard increases by approximately 5°C. The temperature increase of the top side of the seat (approximately 8°C) is caused by using a not insulated connecting piece between the heating element and the seat of the bench. This allows the warming up of the seat due to thermal conduction. The air temperature between the pews increased about 4°C. The most important region of impact for the heating element under the seat is in fact the whole region between the pews (air temperature and turbulence intensity) and near the back of the pew at shoulder height (air velocity).

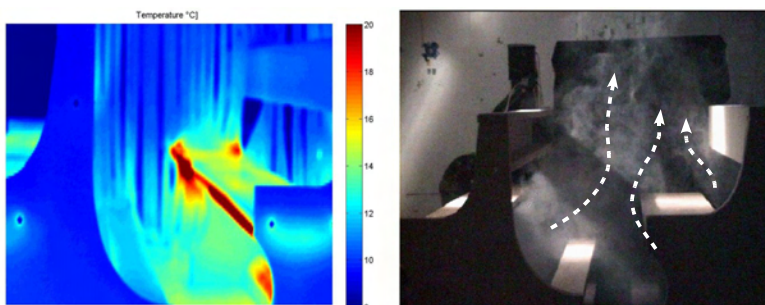

Figure 3.6. Temperature [°C] (left) and air flow (right) as a result of operating the seat heating element

3.7.2 Back heating element

The average temperature of the back heating system was about 35°C. Since the heating element was placed almost vertically, the upper part of the element was warmer than the lower part due to the warm air rising along the element. The performed smoke tests showed that the air curls around the top of the back at shoulder height, see figure 3.7. Therefore, high turbulence intensities were expected in this region. The measurement results showed that the surface temperatures of the kneeler pad and the wooden floorboard increased slightly by approximately 2°C to 3°C. The surface temperature of the seat increased by 5°C due to radiation from the element to the seat. The surface temperature at the back of the pew increased by approximately 13°C, due to the warmed air that rose along it. The air temperatures between the pews increased by at least 2°C with a maximum increase of 4°C in the region near the heating element. As expected, there was a large air velocity introduced at the top of the bench (0.21m/s to 0.63m/s) with a turbulence intensity of 49%.

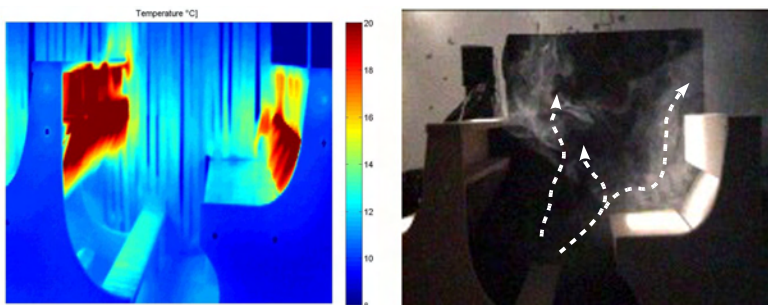

Figure 3.7. Temperature [°C] (left) and air flow (right) as a result of operating the back heating element

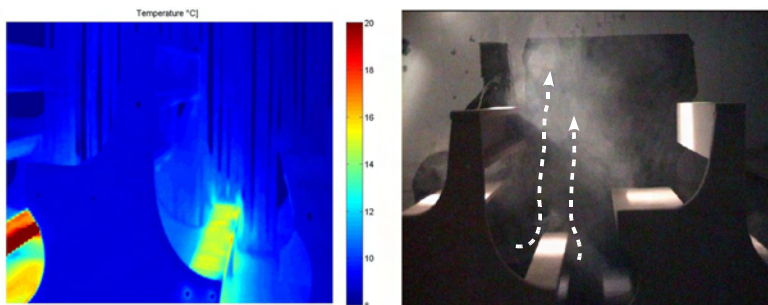

Figure 3.8. Temperature [°C] (left) and air flow (right) as a result of operating the kneeler pad heating element

3.7.3 Kneeler pad heating element

The heating element under the kneeler pad of the benches had a load of 130W. The smoke tests showed that along the sides of the kneeler pad some air rises up, see figure 3.8. At the same position the IR thermographic pictures and the air temperature measurements show a slight increase of air temperature ($\Delta T=2^{\circ}\text{C}$). The measurements also show that the heating element radiated to the wooden floorboard. As a result of this, the temperature of the floorboard increased by approximately 5°C . Although this heating element is only small, it does have an impact on the local climate as far as air velocity and turbulence intensities are concerned. This element had two important regions of impact. The first one was the upper region at shoulder height ($>96\text{cm}$), where an air velocity of 0.12m/s to 0.37m/s and a turbulence intensity varying between 54% and 65% were measured. The second important region was the lower region (near the ankles and feet of the people), where air velocities ranging from 0.10m/s to 0.26m/s and turbulence intensities between 26% and 50% were measured.

3.7.4 Applying the manikin in the climate room set-up

As mentioned in section 3.4, measurements were also conducted when the manikin was seated in the middle bench. The objective of these measurements was to investigate the thermal climate in the benches when people were seated in the benches. Infra-red thermographic pictures were also taken to investigate the effect of the heating elements on the people in the benches. The heating elements were expected to radiate heat directly to the people, thus contributing to a higher level of thermal comfort. Although the air temperatures remain low, the radiant temperature from the heating element is expected to warm the people. The next sections present the influence of the different heating elements on the manikin. In order to compare the different heating elements, these were not simultaneously operated and the infra-red thermographic pictures are shown with the same temperature range.

3.7.4.1 Seat heating element

The element under the seat proved mainly to warm the legs, both front and back, of the person sitting in the benches. A maximum temperature increase of approximately 5°C was recorded. Besides, a slight increase in temperature of the trunk was visible, see figure 3.9, and the temperature increase of the manikins

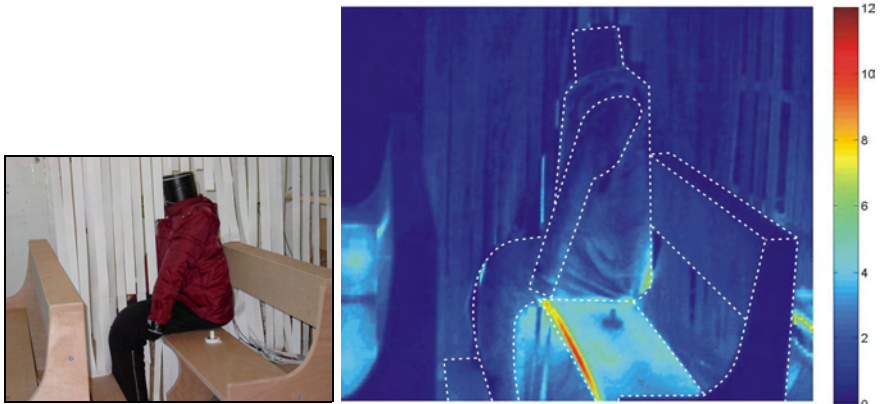

Figure 3.9. Temperature increase [°C] on the thermal manikin as a result of operating the seat heating element

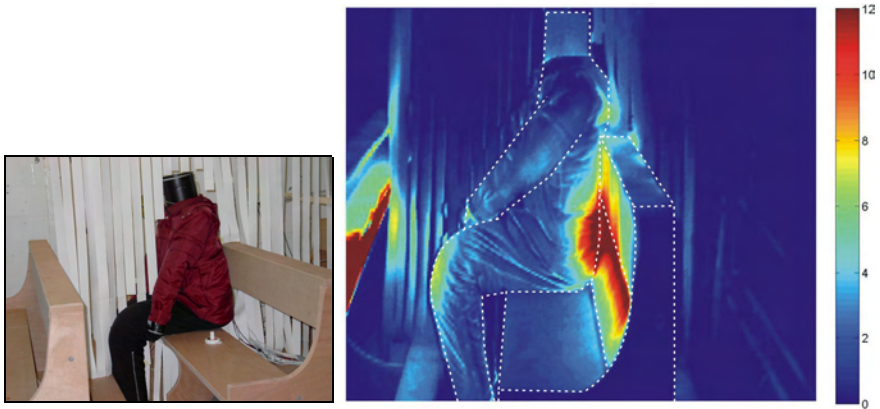

Figure 3.10. Temperature increase [°C] on the thermal manikin as a result of operating the back heating element

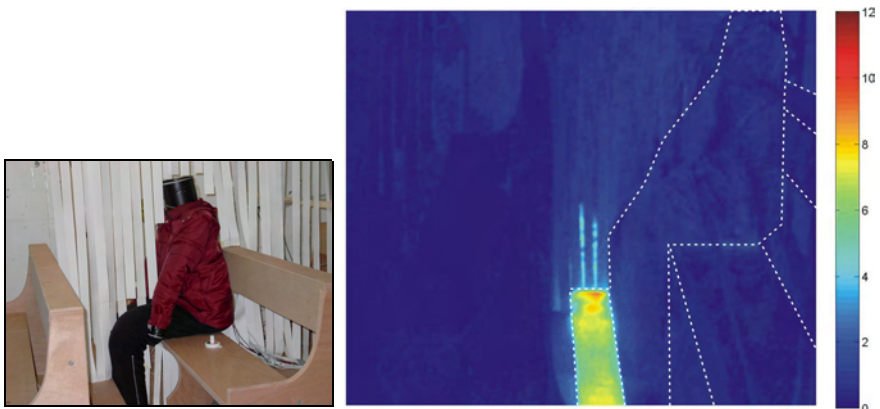

Figure 3.11. Temperature increase [°C] on the thermal manikin as a result of operating the kneeler pad heating element

buttocks results from the increased contact temperature of the seat. On the basis of the criteria specified within the ISO 7730 standard (see table 4.8), we can expect some local discomfort as a result of the seat-heating element. The measurements showed an air velocity of 0.20m/s to 0.25m/s near the neck and the shoulders.

This relatively high air velocity indicated a risk for discomfort resulting from draught. In addition, the combination of the warm surfaces of the heating element ($\pm 30^{\circ}\text{C}$) and the cold surfaces of the walls and benches ($\pm 6^{\circ}\text{C}$) could indicate inconvenient asymmetric radiation. Due to the geometry of the situation, the view factor of the legs to the cold walls is very small compared to the view factor of the legs to the heating element. As a result, the legs experience mostly radiation from the heating system and very little from the walls. Therefore, no problems concerning asymmetric radiation are expected near the legs. A larger problem could be the head, which has a large view factor to the cold walls and only a small view factor to the heating element. The head radiates more heat to the environment than it gains from the heating elements. As a result, the head is colder compared to the rest of the body, which could cause discomfort.

3.7.4.2 Back heating element

According to the thermographic pictures, the heating element in the back has a quite large effect on the manikin. The back of the manikin and the knees were heated by 16°C and 7°C respectively, see figure 3.10.

3.7.4.3 Kneeler pad heating element

Similar to the measurements presented in section 3.7.3, the kneeler pad heating element has little effect when operated alone. Only the kneeler pad itself is warmed up about 6°C , see figure 3.11. There is hardly any temperature increase visible on the manikins clothing, but there is a temperature increase below the element which indicates that the people's feet would be heated. Unfortunately this was not demonstrated in the IR pictures because the manikin had no feet. The temperature of the feet is very important for the overall sensation of thermal comfort. Therefore, the kneeler pad heating element was assumed to have a positive effect on thermal comfort.

However, when the kneeler pad element is operated in addition to the other heating elements, the thermal situation between the benches is more

homogeneous (the heat sources are more equally divided over the bench area). The measurements show that there is less turbulence and the air velocity near the people's feet and legs decreases slightly. The research on thermal comfort (which is explained in chapter 4 of this thesis) showed that the people in the benches complained less about the perception of air movements at their ankles when the kneeler pad element was switched on. So, although the kneeler pad heating element does not radiate to the human body, it does have a positive contribution to the people's thermal comfort.

3.8 Conclusions

From the measurements on the performance of the heating elements, we can conclude that the heating elements slightly influenced the air temperatures and air velocities in and around the bench area. Their largest impact was on the radiant temperature and the turbulence intensity. The seat element has its main influence on the lower part of the bench area, whereas the back heating element mainly influences the mid region. The kneeler pad had very little impact on the local climate, but turns out to be important for the thermal comfort of the people's feet.

The air temperature increased only a few degrees Celsius, thus is still very low (<10°C). On the other hand, the increased temperature on the manikins clothing indicates that the principle of the heating system works. The heat is radiated to the people and contributes to the thermal comfort. However, the heating elements did increase the air velocity and turbulence intensity in the bench area. Especially in the region near the neck and shoulders of the people, relatively high air velocities and turbulence intensities were measured. This has to be taken into account with regard to the human thermal comfort. From studies on thermal comfort (discussed in more detail in chapter 4 of this thesis) we know that in a cold environment (low air temperatures) the air velocity and turbulence intensity become more and more important. The air velocity and turbulence intensity have to be kept low, in order to prevent draught complaints. The heat is not only emitted by radiation but also by convection. To keep the air velocities and turbulence intensities low, free convection from the element should be minimized. To achieve this, one should prevent the cold air to enter, and the warm air to rise from the bench area too quickly. This method was investigated in a variant study that is presented in section 5.2.3.

4 Thermal Comfort

Human thermal comfort plays an important role in judging the performance of heating systems. The aim of the heating systems within this research project was to create a thermal comfort level that people refer to as “slightly cool”. There were three reasons for choosing this level of thermal comfort: 1) it is not advisable to exaggerate the temperature level because it has a direct influence on the relative humidity which can damage the building and its interior. 2) people are more alert in a “slightly cool” environment than they are in a “comfortable” or even “warm” environment, and 3) an increase in temperature level entails an increase in energy consumption, which has to be controlled to prevent high energy costs.

In this chapter, the research with regard to the human thermal comfort is presented. For this study, different approaches were applied:

1. **Comfort experiments with human subjects** in a climate room set-up were performed to investigate the realized thermal comfort level when operating the local bench heating system.
2. A study has been conducted to assess whether it is possible to predict the human thermal comfort with the help of **existing international standards**.
3. A first attempt has been made to investigate whether a (dynamic) **thermophysiological model** could be used to predict the human skin temperatures as a result of the local thermal indoor environment.

The last section of this chapter gives recommendations for future research on human thermal comfort, particularly when performing experiments with volunteers.

4.1 Introduction

Thermal comfort is defined as that condition of mind which expresses satisfaction with the thermal environment [ISO 7730:2005]. Dissatisfaction may be caused by discomfort of the human body as a whole (expressed by the PMV and PPD indices, that are explained in section 4.4.1), or by local discomfort. Local discomfort could occur when the heat exchange between a body part and its environment is large compared to that of the rest of the body. Possible causes of local discomfort are: asymmetric radiation, draught and an increased heat loss due to contact with cold surfaces (e.g. cold bench or floor), which may exist in a non-uniform environment. The use of a local radiant bench heating system may introduce such a non-uniform thermal climate in the benches, thus increasing the risk of local discomfort. Therefore, both the thermal comfort of the body as a whole and the risk of local discomfort were investigated.

4.2 Thermal comfort study with volunteers

In thermal comfort studies the use of volunteers is well known. Their skin temperatures may be measured e.g., and at the same time the volunteers are asked to fill in a questionnaire. This makes it possible to compare the physiological measurement results with personal appreciations of the thermal comfort. The measured skin temperatures can be evaluated using criteria for human thermal comfort (see table 4.1:). These comfort criteria specify the temperature regions in which people averagely experience comfort or discomfort. In between these regions, the situation is experienced as neither comfortable nor uncomfortable. The comfort criteria are derived from [Lotens 1988] and the ISO/TRN 11079 standard [ISO/TR 11079:1993].

Table 4.1: Comfort criteria of volunteers' skin temperatures [ISO/TR 11079:1993]

	Skin temperature [°C]	
	Comfort	Discomfort
Skin (area weighted mean temperature)	32-33	< 31 or > 35
Fingers	27-34	< 20
Toes	24-34	< 17

In the climate room set-up, we performed comfort experiments with volunteers, similar to the comfort measurements that have been performed by Rissanen in the church in Italy [Camuffo et al. 2006]. In the climate room set-up, 43 volunteers were subjected in 10 sessions to an experiment to evaluate the **thermal sensation** and **thermal comfort** for different configurations of the local heating system in the church benches. Table 4.2 presents the number of volunteers for each combination of heating elements used within this research. The volunteers were briefed on the procedures, and consented to participate in the study.

Table 4.2: Number of volunteers per heating system configuration

Combination of heating elements	Number of volunteers	Measurement session
Seat, back, knee (<i>sbk</i>)	11	1, 2, 3
Seat, back (<i>sb</i>)	10	4, 8
Seat, knee (<i>sk</i>)	14	6, 7, 10
No elements operated (<i>none</i>)	8	5, 9

4.2.1 Measurement procedure

Sex, age, length, weight and the clothing they wore, were recorded for all volunteers. There were 13 female and 30 male subjects aged between 44 and 84 years (mean age: 56). Only people of 44 years or older were chosen because we wanted to create, as much as possible, a population resembling an average, ageing congregation in order to approach the societal reality. Length and weight ranged from 1.60m to 1.90m (mean length: 1.74m) and from 60kg to 105kg (mean weight: 79kg) respectively. These quantities were specified by the volunteers themselves. Furthermore, we asked the people whether they used any medication. The thermal insulation of the peoples clothing was determined using ISO 9920 [ISO 9920:1995].



Figure 4.1. Volunteers in the climate room set-up

First, the volunteers spent 15 minutes in a pre-cooling room at a temperature of 13°C. After that, they entered the climate room and stayed there for about 70 minutes. During their stay in the climate room (figure 4.1), the volunteers were alternately asked to sit, kneel or stand. The skin temperatures of each volunteer were measured with sensors (NTC-thermistors, DIGI-Key, USA) at 11 positions: toe, foot, calf, thigh (front and back side), back, chest, finger, hand, forearm and forehead. The data were sampled at 1-minute intervals using data loggers (SmartReaderPlus8, ACR Systems, Canada) that were placed in a small bag around the volunteers' hips to not impede them in their movement. All sensors were attached to the left side of the body. The results of these measurements were used to evaluate the local thermal sensation and thermal comfort of the body parts mentioned above. Since most comfort criteria are related to the thermal comfort of the whole body, a mean skin temperature is needed to compare the measurement results to these criteria. Therefore, an area-weighted mean skin temperature ($\theta_{sk,m}$) is calculated from the 11 skin temperatures of the body parts.

At specific times during the experiments, the volunteers completed a questionnaire which included questions on their perception of thermal sensation, thermal comfort and air movements. These questionnaires were composed according to the international standard ISO 10551 [ISO 10551:2001], and are presented in appendix B.3.

With thermal sensation, people indicate that body parts feel warm or cold, without judging whether they like it or not. With thermal comfort, people do rate the thermal comfort level (comfortable or not). Not only thermal sensation and thermal comfort were investigated, the volunteers were also asked to specify whether they felt air movements and what their thermal preference was, i.e. whether they would prefer a climate that was warmer, the same, or cooler.

4.2.2 Results of the comfort measurements

All data (measurement results of the local climate, personal details, measured skin temperatures, as well as the responses to the questionnaires) are presented in detail in the report of Schoffelen [Schoffelen et al. 2005]. In this section, the analysis of the most important results are presented according to the international standards ISO/TR11079 and ISO/TR 10551.

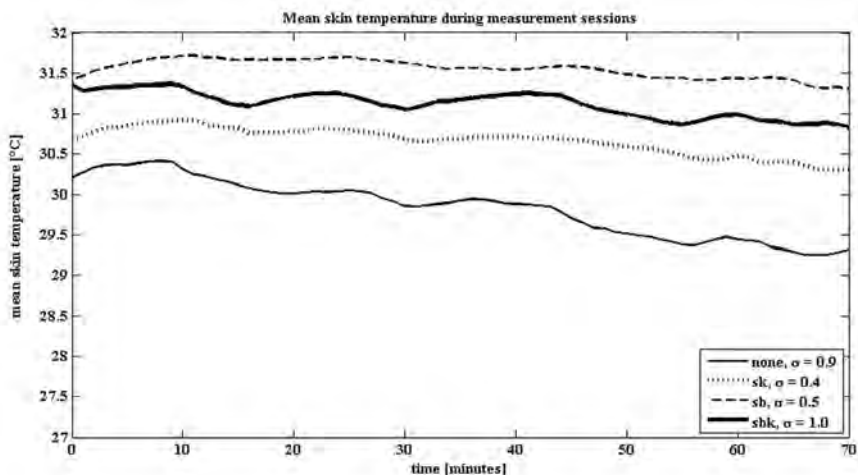

Figure 4.2. Average mean skin temperatures during the measurement sessions with different heating system configurations

Figure 4.2 presents the mean skin temperatures of the volunteers per heating configuration. The initial skin temperatures of the volunteers at the start of the measurements already are not equal. Consequently, it is not correct to draw conclusions based on the absolute values of the skin temperatures at the end of the measurements. It may be more suitable to evaluate the performance of the heating configurations by examining the alteration in skin temperature between the start and the end of the measurements.

Figure 4.3 presents the measured skin temperatures at the start ($t=0$) and at the end ($t=70\text{min.}$) of the measurements for the different heating system configurations. Only the mean skin temperature and the temperature of the fingers and toes are presented in this figure, because these are the temperatures for which comfort criteria are specified in the international standard ISO/TR11079. The measured temperatures of the other body parts are presented in Appendix B.4.

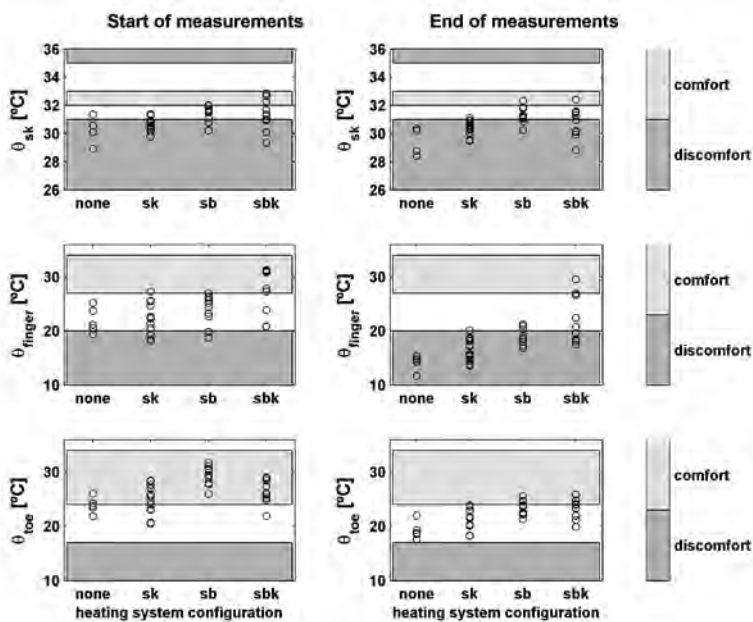

Figure 4.3. Measured skin temperatures of the volunteers at the start and the end of the measurements, grouped by heating system configuration. Comfort criteria derived from [Lotens 1988] and [ISO/TR 11079:1993]

The light grey areas in figure 4.3 represent the temperature ranges in which a person is expected to feel comfortable, whereas the dark grey areas represent the temperature ranges in which a person would feel very uncomfortable. The areas that are kept blank represent the temperature range in which neither comfort nor discomfort is experienced. Note that the scale of the y-axis in the graphs of the mean skin temperature, is different from that of the other temperatures.

These measurements show that the mean skin temperature decreases with all heating system configurations. The figure shows that the temperature range in which the mean skin temperature of the whole body is expected to be comfortable, is very narrow (between 32°C and 33°C), and that the mean skin temperatures of the volunteers do not differ much. In all configurations, there is only a slight decrease in mean skin temperature (from 0.9°C in configuration “none” to 0.1°C in configuration “sb”). It is interesting to see that the temperature decrease in configuration “sb” is less than that in configuration “sbk” where more heating elements are operated. Since the mean skin temperature is an area weighted temperature, the separate body parts are examined to find an explanation for these differences in mean skin temperature.

At the start of the measurements, most volunteers already have a finger temperature which is not really comfortable, but not uncomfortable. At the end of the measurements the finger temperature of all volunteers in the configurations “none” and “sk” is within the discomfort zone. In the configuration “sb” the finger temperature is slightly higher, and in the configuration “sbk” there are even some volunteers whose finger temperature is in the comfort zone. The temperatures of the toes however, indicate that they are almost all in the comfort zone at the start of the measurements, and almost all shift to the ‘neutral’ zone at the end of the measurements. Even when there is no heating system operated, the temperatures of the toes do not reach the level of discomfort at the end of the measurements.

Table 4.3: presents the average increase/decrease of the skin temperature of the various body parts during the measurement sessions. It shows that most body parts cool down, but the chest and back warm up. The extremities (head, fingers, feet and toes) cool down the most.

Table 4.3: Mean skin temperature increase [°C] of the various body parts during the measurements

Body part	Heating system configuration			
	none	sk	sb	sbk
Finger	-7.8	-5.9	-4.9	-5.8
Hand	-5.5	-3.7	-2.9	-3.0
Arm	-0.7	-0.4	-0.3	-0.4
Head	-0.9	-0.6	-0.9	-1.7
Chest	0.8	1.0	1.2	0.2
Back	0.2	0.7	1.3	1.1
Thigh front side	-0.4	-0.7	0.1	-0.4
Thigh back side	-1.8	-0.5	-0.5	-1.1
Calf	-1.6	-0.5	-0.3	-1.5
Foot	-2.8	-2.4	-3.2	-1.4
Toe	-4.6	-4.0	-5.8	-3.5

In addition to the temperature of individual body parts, the maximum temperature gradient over the whole body might be an important parameter for the perception of human thermal comfort. The analysis of the measurement data showed that a more advanced heating configuration lead to a smaller temperature gradient over the whole body (see table 4.4:). At the end of the measurements, the temperature gradient over the body for the configuration without heating elements ('none') reaches a value of 19.3°C, whereas with the configuration 'sbk' the temperature gradient is 13.5°C.

However, the initial temperature gradient over the whole body of the volunteers in the different heating configurations is already different at the start of the measurements. Therefore, it might be more appropriate to compare the increase of this temperature gradient during the measurements. Table 4.4: shows an increase in temperature gradient ranging from 5.5°C in the configuration 'sbk' to 8.3°C in configuration 'none'.

Table 4.4: Averaged maximum skin temperature gradient over the body, averaged per heating system configuration, at the start and the end of the measurements and the increase during the measurements

System configuration	Temperature gradient over the whole body		
	Start	End	Increase
none	11.0	19.3	8.3
sk	11.7	18.1	6.4
sb	10.0	15.9	5.9
sbk	8.0	13.5	5.5

4.2.3 Results of the questionnaires

The questionnaires that were filled in by the volunteers were analysed according to Annex B of the international standard ISO 10551:2001. Statistical analysis showed that one outlier was present out of the 43 questionnaires completed. The outlier's was rejected on the basis of several aspects. First, the outlier's age differed too much from the age of the rest of the population. Secondly, the outlier's votes differed extremely from those of the other volunteers. And the third reason was, that there was no correlation detected between the outlier's measured skin temperatures and the answers of the questionnaire completed by the outlier. Therefore, this person was excluded from further statistical analysis and a population of 42 volunteers remained.

The first question the volunteers had to answer regarded the thermal sensation (i.e. feeling warm or cold) in general and for various body parts. The volunteers specified thermal sensation votes (TSV) on an (asymmetric) discrete 8-point scale ranging from -4 (very cold) to +3 (hot). To compare the results of the different thermal situations (i.e. the different heating system configurations), the mean value of the thermal sensation votes (TSV) is determined. Figure 4.4 presents the mean TSV of the 4 most important body parts. The figure shows that people rated their thermal state as 'neutral' to 'slightly cool' at the start of the measurements when they just entered the climate room. At the end of the measurement session, the TSV of the configurations 'none' and 'sk' are 'slightly cool' to 'cool' and even almost reaching the level of 'cold'. Notice that there is quite a difference in TSV between the different body parts in these two configurations, whereas in the configurations 'sb' and 'sbk' the TSV of the different body parts are almost rated equally. The decrease in TSV seems more

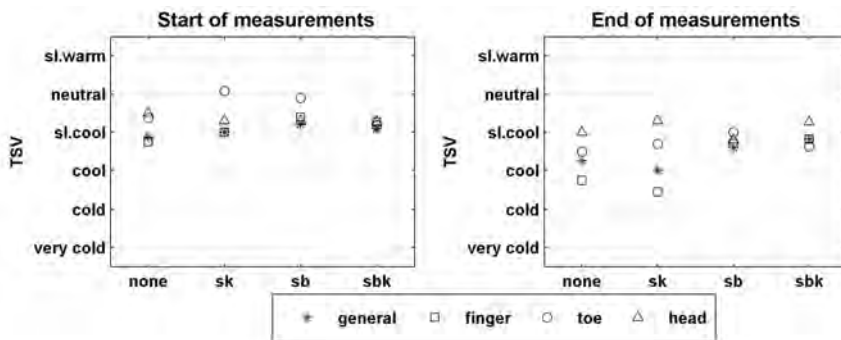

Figure 4.4. Mean TSV rated by the volunteers for different body parts and in different heating system configurations

evident for the configurations without the back heating element than for those with this element. This indicates that the configurations ‘sb’ and ‘sbk’ perform better than the configurations ‘none’ and ‘sk’.

The standard states that the central tendency of the TSV, which yields an observed mean vote, can be compared with the Predicted Mean Vote (PMV) determined according to ISO 7730. Figure 4.5 presents this observed (realized) TSV in relation to the (predicted) PMV. This comparison shows that at the start of the measurements, the volunteers rate their thermal sensation more positive than the calculated PMV. But, at the end of the measurements, after a 70 minutes stay in the cold environment, they rate their thermal sensation worse than the calculated PMV index. As mentioned in section 4.2.2, the skin temperatures of the volunteers decrease in time, as well as the volunteers’ thermal sensation. With all configurations, the first voted TSV is more positive than the predicted PMV.

The predicted PMV is higher for the configuration “seat, knee” than for the configuration “none”. However, the TSV of the volunteers in the experiments did not agree with this prediction. Operating the seat and knee heating elements increased the air movements which caused the cooling of body parts, especially the fingers. This local phenomena resulted in a negative influence on the peoples’ overall thermal sensation. The negative influence due to draught and asymmetric radiation probably had a larger effect on the TSV than the positive influence (increase in air and radiant temperature) of the extra heating supplied.

The PMV is a static value and does not account for a time effect. In the experiments however, the TSV value decreases in time: in all configurations the first TSV was higher than the last one.

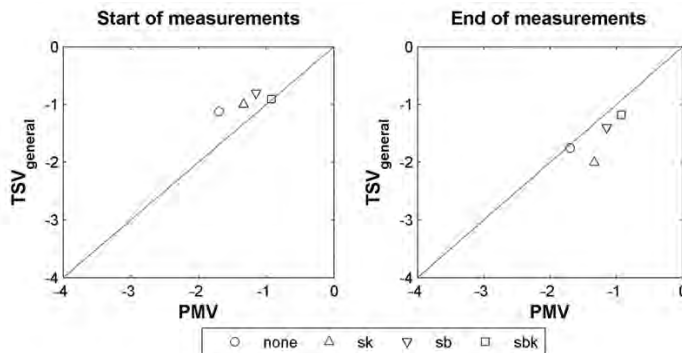

Figure 4.5. Observed mean TSV in relation to the PMV index determined according to ISO 7730, for each heating system configuration

Secondly, the volunteers indicated the thermal comfort level (i.e. comfortable or not) in general and for various body parts. When looking at the questions about thermal comfort (figure 4.6) it is noticed that, at the start of the measurements, the toes and head are rated as comfortable with all heating system configurations. The fingers and the general comfort is rated as slightly uncomfortable in the configurations ‘none’ and ‘sk’, and between comfortable and slightly uncomfortable for the ‘sb’ configuration. At the end of the measurements, there is a shift towards a slightly uncomfortable and even an uncomfortable level for the configurations ‘none’ and ‘sk’. In the configuration ‘sb’, there is only a slight decay in comfort vote: the volunteers still rate the comfort level as ‘slightly uncomfortable’ which complies with the desired comfort level in this research (see the beginning of this chapter). Although the thermal comfort level for the head, fingers and toes in the configuration ‘sbk’ is rated as ‘slightly uncomfortable’, the general thermal comfort level is rated as ‘comfortable’. This indicates that configuration ‘sbk’ performs better than the configuration ‘sb’.

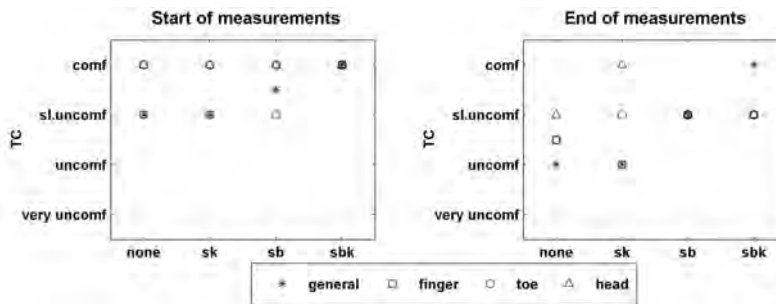

Figure 4.6. Median thermal comfort vote rated by the volunteers for different body parts and in different heating system configurations

After that, the volunteers were asked about their thermal preference. Would they prefer an environment which is ‘warmer’, ‘cooler’ or ‘neither warmer nor cooler’? Figure 4.7 presents the median vote of the volunteers. At the start of the measurements, the volunteers would prefer a ‘slightly warmer’ environment in all heating system configurations. At the end of the measurements, only the rating in the configuration ‘sb’ is the same. In the other configurations, people would prefer a ‘warmer’ environment.

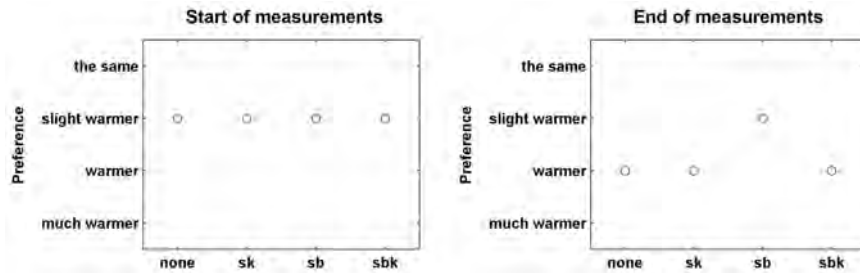

Figure 4.7. Median thermal preference vote rated by the volunteers for different heating system configurations

In addition to the questions which are specified in the international standard ISO 10551:1995, the volunteers were also asked to indicate whether they felt air movements. This was done to investigate the risk of a possible draught feeling. In figure 4.8 the volunteers' perception of air movements is presented. It shows that more heating systems lead to more perceived air movements. Especially at the head and in general, the volunteers experience air movements between 'weak not continuous' and 'weak continuous'. The volunteers indicate no difference between their left and right side.

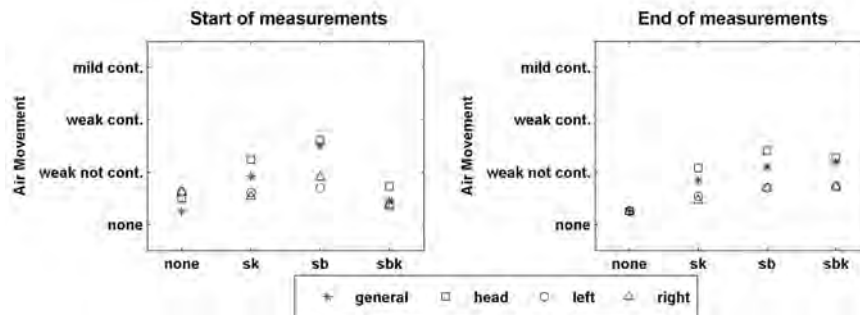

Figure 4.8. Mean level of air movements indicated by the volunteers for different body parts and in different heating system configurations

4.2.4 Statistical analysis of the results

The strength of the linear relationship between two variables can be expressed with the correlation coefficient (r). This coefficient can range from -1 to +1 where the sign out the front indicates whether there is a positive or negative correlation. When $r=1$ or -1, there is a perfect correlation, whereas $r=0$ indicates

that there is no relationship between the two variables. When calculating the correlation coefficient between two variables, the statistical significance level is also calculated. This significance level (p) provides a test of the null-hypothesis that the correlation coefficient in the population is 0. Furthermore, N specifies the size of the sample (e.g. the amount of questionnaires filled in) at which the statistical analysis is performed. There was one outlier, based on the Z -value for age (>3), thus the number of questionnaires/measurements analysed statistically is $N=42$.

In this research, the correlation between the volunteers thermal sensation (TSV) and their thermal comfort vote (TC) has been calculated, both at the start and at the end of the measurements. At the start of the measurements ($t=0$) there is a **strong correlation between TSV and TC** ($r=0.703$, $N=42$, $p<0.01$). At the end of the measurements the correlation is **very strong** ($r=0.883$, $N=42$, $p<0.01$). Both correlations are significant at the 0.01 level, which means that it is not likely to have occurred by chance.

Repeated Measures ANOVA

In this research, we were not only interested in the correlation between the thermal sensation and the thermal comfort, but also whether there was a difference in thermal sensation/comfort perception between the different heating system configurations. The data collected from the questionnaires has been analysed statistically. The results of the statistical analysis are presented in table 4.5. Since the same questions have been asked multiple times during the comfort measurement sessions, a one-way Repeated Measures ANOVA (Analysis of Variance) has been performed [Pallant 2001]. This analysis shows that there is a **statistically significant effect for time** in the TSV of the bottom and that of the fingers, and in the general TC vote and that of the fingers. For all four, the multivariate partial eta squared (η^2_p) is larger than 0.14, which indicates that there is a large effect size, thus a large strength of association.

There are also **significant differences between the heating systems**. 24.8% of the variance in TSV_{bottom}, 19.3% of the variance in TSV_{finger}, 18.8% of the variance in TC_{gen} and 18.4% of the variance in TC_{finger} can be explained by the heating system the participants were exposed to.

Table 4.5: Statistical results of the one-way Repeated Measures ANOVA

	Effect	Variable	Wilks' Λ	F	df	η^2_p
1	TSVbottom		.703*	2.869	5,34	.297
		heatsys		4.176*	3,38	.248
2	TSVfinger		.497***	6.872	5,34	.503
		heatsys		3.029*	3,38	.193
3	TCgen		.651**	3.653	5,34	.349
		heatsys		2.941*	3,38	.188
4	TCfinger		.514***	6.429	5,34	.486
		heatsys		2.860*	3,38	.184

Note: N=42 * $p \leq .05$. ** $p \leq .01$. *** $p \leq .001$.

4.2.5 Physical measurements (local thermal climate)

During all comfort experiments, the following environmental parameters were measured: air temperatures, surface temperatures (of the benches, heating elements and the room boundaries) and the relative humidity of the air. The results of these measurements will be used as input data for predicting the thermal comfort level with help of the International Standards that are explained in section 4.4.1 and 4.4.2 as well as for the thermophysiological computer model which is presented in section 4.5.

The measurement positions (located around the 2nd and 3rd bench in the climate room set-up) are given in figure 4.9.. Due to an imperfect measurement protocol, the air velocities were recorded in only one measurement session for each heating system configuration. During all measurement sessions, the relative humidity was measured at one position using a sensor which was placed in the middle bench. The readings of this sensor were logged with a 1-minute interval. Both air and surface temperature measurements were conducted with a 30 second interval, using NTC (negative temperature coefficient) sensors. The air temperature sensors below the seat of the benches appeared to be influenced by the radiation from the heating elements [Grooten and de Vaan 2005], thus the measured temperatures are a combination of the air and the radiant temperature. The air velocity was measured with hot sphere anemometers (DANTEC 54R10). In order to calculate the turbulence intensity, which is defined as the ratio of the standard deviation of the local air velocity to the local mean air velocity, the sampling frequency was set at 10Hz. For each measurement session, the mean radiant temperature between the benches was calculated at one point using the measured

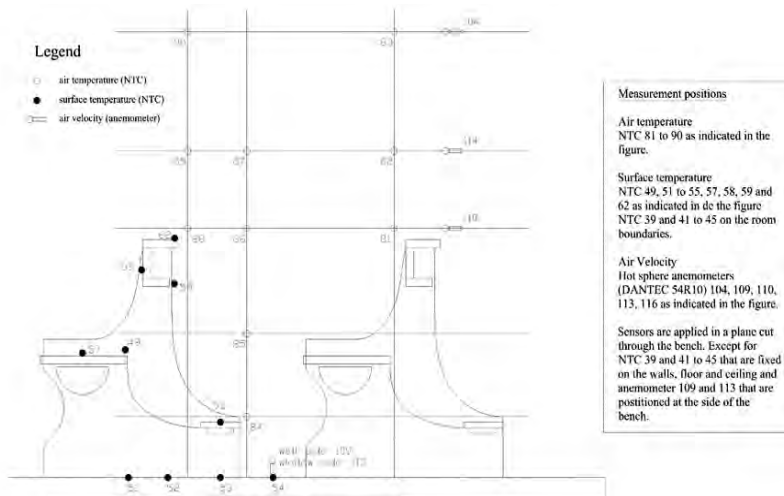

Figure 4.9. Measurement positions for air temperature, surface temperature and air velocity measurements. Measurement plane positioned at $\frac{1}{4}$ of the bench length (measured from the wall side). The numbers refer to the individual sensor numbers

surface temperatures. This point represents the location of the sternum of a person seated on the bench. The calculation of the radiant temperature was performed in accordance to ISO 7726 [ISO 7726:1998].

4.3 Equivalent Homogeneous Temperature (EHT)

We searched for a method that allows us to judge thermal comfort and local discomfort under cold climate conditions. The car industry, for example, pays much attention to the research on thermal comfort under non-uniform circumstances. Generally, they use thermal manikins for their research. Since a thermal manikin is split up in different body segments, it is possible to evaluate the thermal circumstances of the body parts separately. For this evaluation, the **Equivalent Homogeneous Temperature (EHT)** per body segment, is used [Wyon 1989]. This method registers for each body part the power supply needed to maintain a certain skin temperature of the thermal manikin. On the basis of this power supply and the accompanying (measured) skin temperature, an equivalent homogeneous temperature (EHT) is calculated. This temperature is used to represent the thermal environment in a simple way. It is the air temperature in a room in which the air temperature equals the radiant temperature and the air

velocity is ≤ 0.05 m/s. In this simplified situation, the heat exchange between the manikin's body segments and their environment is comparable to that in the real, more complex environment.

In [Bohm 1991], with the help of volunteers, upper and lower boundaries as well as ideal values for the EHT are determined for each body segment, for both winter and summer conditions. When the value of EHT is between these boundaries, the expected percentage of dissatisfied people is below 20%. Because the EHT value is calculated both for the whole body as well as for each separate body segment, this method is appropriate for rating human thermal comfort and signalling local discomfort.

In this thesis an attempt was made to calculate the EHT for the manikin that was used in the climate room measurements (see section), but unfortunately this did not work. The EHT method was unsuccessful for rating thermal comfort because the manikin employed was not a real thermal manikin, but it was only representing a human being as a heat source. With this type of manikin (heat source) the energy supply to the body segments remains constant and no thermal regulation is possible.

4.4 Predicting thermal comfort with the help of International Standards

One of the main research questions regarding thermal comfort was, whether existing international standards could be used to **predict the human thermal comfort** in a relatively cold, non-uniform indoor environment in which people are warmed by local radiant heating elements.

There are two existing international standards which should be considered when evaluating the thermal comfort in a relatively cold environment: ISO 7730 “Moderate thermal environments - Determination of the PMV and PPD indices and specification of the conditions for thermal comfort” [ISO 7730:2005] and ISO/TR 11079 “Evaluation of cold environments - Determination of required clothing insulation (IREQ)” [ISO/TR 11079:1993]. These standards are discussed in this section, and were applied to the situation created in the climate room. The predictions based on these standards are compared to the outcomes of the climate room experiments. If the results of both predictions and experiments

are in line with each other, it may be justified to use these standards as a predictive tool in this specific situation: in a church with a local bench heating system and under cold winter conditions.

The terms “thermal comfort” and “thermal sensation” are often used as equivalents. However, this is not correct. Some people might experience a cold sensation as comfortable, while others do not. ISO 7730 describes a method to predict thermal sensation. In this standard, thermal comfort is treated as a direct derivative of thermal sensation. ISO/TR 11079 links a certain level of thermal insulation of the clothing to a “cool” or “neutral” sensation. Therefore, these standards cannot be used to predict thermal comfort. At the most, thermal sensation can be determined.

4.4.1 ISO 7730 - Calculation of the PMV and PPD indices

A commonly accepted tool for rating thermal comfort is the comfort equation of Fanger, which is adopted in the Standard ISO 7730 [ISO 7730:2005]. The purpose of this International Standard is: a) to present a method for predicting the thermal sensation and the degree of discomfort (thermal dissatisfaction) of people exposed to moderate thermal environments, and b) to specify acceptable thermal environmental conditions for comfort. The International Standard is expected to apply with good approximation for healthy men and women in most parts of the world. This standard applies to people exposed to indoor environments where the aim is to attain thermal comfort, or indoor environments where moderate deviations from comfort occur.

4.4.1.1 PMV

The mean value of the votes of a large group of persons on this thermal sensation scale can be predicted when the parameters mentioned in table 4.6 are within the specified range. This mean value is called the **predicted mean vote (PMV)**. Based on human and environment related parameters, a PMV on a seven-point scale between -3 (cold) and +3 (hot) is calculated.

Table 4.6: Necessary parameters to calculate predicted mean vote (PMV) and their recommended interval

Parameter (symbol)	Unit	Recommended interval
Rate of mechanical work (W)	W/m ²	-
Metabolic rate (M)	W/m ²	46 to 232
Thermal insulation clothing (I_{cl})	clo	0 to 2
Air temperature (θ_a)	°C	10 to 30
Mean radiant temperature (θ_r)	°C	10 to 40
Vapour pressure (p_a)	Pa	0 to 2700
Air velocity (u_a)	m/s	0 to 1

A PMV for all volunteers who took part in the sessions with the same configuration of heating systems was calculated. This calculation was based on the physical measurements of the thermal climate in each session and the estimated thermal insulation of the clothing. According to [ISO 8996:2004], the metabolic rate (M) and the rate of mechanical work (W) were approximated to be respectively 75 W/m² and 0 W/m² for all volunteers in all sessions. The air temperature used in each calculation was the mean value for positions 82 and 84 (see figure 4.9.) averaged over the duration of the session. For the air velocity, the maximum of the five measured mean air velocities was applied. The relative humidity as well as the thermal insulation of the clothing were averaged over the measurement sessions. These parameters and the results are presented in table 4.7.

Table 4.7: Calculated PMV, PPD and IREQ indices (see section 4.4.2) based on the mean values for climatic conditions (temperatures, relative humidity and air velocity) and clothing insulation for four heating element configurations. ($M=75W/m^2$, $W=0W/m^2$)

Configuration	θ_r [°C]	θ_a [°C]	RH [%]	u_a m/s]	I_{cl} [clo]	PMV [-]	PPD [%]	IREQ _{min} [clo]	IREQ _{neut} [clo]
Seat, back, knee	20.0	14.0	70	0.4	1.25	-0.89	22	0.89	1.35
Seat, back	20.0	13.5	77	0.5	1.25	-1.03	28	0.96	1.41
Seat, knee	11.0	10.5	85	0.1	1.28	-1.30	41	1.39	1.85
None	8.0	9.0	85	0.1	1.25	-1.72	63	1.62	2.08

The standard states that the PMV index should only be used to rate a thermal environment, when the values of PMV are between -2 and +2, and when the six parameters are within the recommended interval (see table 4.6). In configuration

'none', the mean radiant temperature and the air temperature were just outside the specified intervals. In configuration 'sk', they were very close to the lower limit. Since the PMV indices are between -2 and +2 and the deviation of the parameters to the recommended interval is only small, usage of this index is assumed to be permissible.

To estimate the differences between the volunteers, a predicted mean vote (PMV) was calculated for each volunteer that participated in the experiments. These results are presented in appendix . The predicted PMV ranges from -0.42 (volunteer 2 in session 1) to -1.91 (volunteer 18 in session 5).

4.4.1.2 PPD

In addition to the PMV, a **predicted percentage of dissatisfied (PPD)** can be calculated. This value represents the percentage of people in a group that are thermally dissatisfied (i.e. the percentage of people that will probably vote +3, +2, -2 or -3 on the thermal sensation scale). In the configurations 'sbk' and 'sb' the PPD is 22% and 28% respectively, whereas in the configurations 'sk' and 'none' the PPD even reaches values of 41% and 63% respectively (see table 4.7).

4.4.1.3 Local thermal comfort

ISO 7730 also provides criteria to evaluate local thermal discomfort caused by draught, a vertical air temperature gradient, warm and cool floors or radiant asymmetry. In this study, draught, the vertical air temperature gradient and the radiant asymmetry are relevant (see table 4.8:).

If air velocities larger than 0.15 m/s occur, discomfort due to draught is expected. Besides, the combination of warm surfaces (e.g. surfaces of the heating systems) and cold surfaces (e.g. the walls) could lead to inconvenient asymmetric radiation. The standard advises to keep this asymmetry below 10K when performing light, mainly seated work indoors during winter (based on a metabolism of 70 W/m² and a heat resistance of the clothing of about 1.0 clo). Note that the heat resistance of the clothing worn in the cold environment of the climate room (and church) is larger than 1.0 clo.

Table 4.8: Criteria for preventing local discomfort

Parameter		critierion
Air velocity	u_a	≤ 0.15 m/s
Air temperature gradient (head – ankles)	$T_{a,1.1m} - T_{a,0.1m}$	< 3 K
Asymmetric radiation	$T_{r,warm} - T_{r,cold}$	< 10 K

Draught

According to ISO 7730, the **draught risk (DR)** - or so called percentage of people dissatisfied caused by draught – is approximated by the following empirical expression:

$$DR=(34-\theta_a)*(u_a-0.05)^{0.62}*(0.37*u_a*TI+3.14), \quad (4-1)$$

where

DR	=	percentage dissatisfied due to draught	[%]
θ_a	=	local air temperature	[°C]
u_a	=	local air velocity	[m/s]
TI	=	local turbulence intensity	[%]

This is an empirical formula, based on experiments with human subjects exposed to temperatures between 20°C and 26°C, mean air velocities ranging from 0.05m/s to 0.4m/s and turbulence intensities from 0% to 70%. In the standard, a percentage of dissatisfied due to draught lower than 15% is recommended.

Using this formula to predict the draught risk for the different heating system configurations, it was concluded that discomfort due to draught can be expected for all configurations. This is mainly caused by the low air temperatures and less by the air velocity and turbulence intensity.

For the configurations “none” and “sk” the mean air velocity (averaged over the duration of the experiments) was only 0.1m/s, but the low air temperature caused DR to be too high (>15%). Using 10°C for the air temperature and 20% for the turbulence intensity, the calculated DR is 15%. For the configurations “sbk” and “sb” the mean air velocities were respectively 0.4m/s and 0.5m/s. Even when assuming that there was no turbulence at all, an air temperature of at least 25°C would be required to meet the recommendation for DR.

As mentioned earlier, the draught risk equation is an empirical equation, based on experiments in an office environment (with temperatures between 20°C and 26°C) where people wear standard clothing. The situation in this research is quite different. First of all, the air temperature in the benches is quite low (about 10°C). In addition, the people wear thick winter clothing and their activity level and metabolism is very low. In such a situation, people are likely to experience

the air flows and turbulence intensity different from the people in the office environment. From these results, we conclude that the DR formula cannot be applied in this cold situation.

For outdoor environments (with much larger air velocities) a wind chill factor can be calculated. However, for a relatively cold indoor environment as it exists in this church during winter, no information on the perception of draught is available. The general expectation is that peoples' tolerance of air movements decreases when the temperature decreases. This could mean that the formula underestimates the draught risk in the relatively cold situation which is present in the climate room.

The subjects indicated whether they felt air movements, but they were not asked to specify if these movements were perceived as draught. Therefore it is not possible to determine a relation between the calculations and the comfort measurements.

Temperature gradient

The standard specifies that the air temperature difference between 1.1m (head) and 0.1m (ankles) height should not exceed 3K. This difference can be determined rather easily from the air temperature measurements at positions 82 and 84 indicated in figure 4.9. During the experiments, the 3K limit was not reached. Most of the time the difference was less than 1K, and peeks up to 2.5K occurred incidentally.

Radiant asymmetry

Radiant asymmetry is defined as the difference between the plane radiant temperatures of the opposite sides of a small plane element. The calculation is described in an international standard: ISO 7726 [ISO 7726:1998]. In ISO 7730, maximums of 10K and 5K radiant asymmetry on respectively a small vertical and a small horizontal plane, both at 0.60m above the floor, are recommended to prevent local discomfort. Radiant asymmetry on a horizontal plane is probably a problem in this case because, when the heating systems are operated, the upper half of the room is cold in comparison to the lower half. This will cause the radiation heat loss to be distributed unevenly over the body.

4.4.2 ISO/TR 11079: Calculating the required thermal insulation of the clothing

This standard proposes methods and strategies to assess the thermal stress associated with exposure to cold environments. Cold stress is suggested to be evaluated in terms of both general cooling of the body, and local cooling of particular body parts (e.g. extremities and face). The method applies to continuous, intermittent and occasional exposure, and to indoor as well as outdoor work [ISO/TR 11079:1993].

The standard gives a method to calculate the required thermal insulation of the clothing. $IREQ_{min}$ specifies a minimal thermal insulation level of the clothing, required for the cooling of the body not to exceed the highest allowable heat loss during professional work. $IREQ_{neut}$ specifies a thermal insulation level of the clothing that maintains the heat balance of the human body. This does not necessarily equal a situation of thermal comfort.

The resultant thermal insulation of the clothing (I_{clr}) is calculated and equals $0.9 \cdot I_{cl}$. A resultant thermal insulation of the clothing (I_{clr}) satisfying $IREQ_{min} < I_{clr} < IREQ_{neut}$ is recommended. This corresponds with an expected PMV score between “slightly cool” (-1) and “neutral” (0).

4.4.2.1 Calculating the required thermal insulation of the clothing

For the calculation of the IREQ indices, the same input as for the calculation of the PMV was applied (table 4.6). The input and the results per configuration are also presented in table 4.7. This table shows that the thermal insulation of the clothing (I_{cl}) for the configurations “sbk” and “sb” is $1.25clo$, which is between the required IREQ values for these configurations. As expected, the predicted PMV is between 0 and -1.

Finally, an analysis was conducted with the mean value of TSV for all volunteers in the sessions with the same configurations of heating systems (figure 4.4). These votes were compared to the IREQ indices presented in table 4.7. For the configurations “sbk” and “sb” the mean resultant thermal insulation satisfies $IREQ_{min} < I_{clr} < IREQ_{neut}$. The mean thermal sensation vote (TSV) at the beginning of these sessions was ≥ -1 (-0.91 and -0.70) which is consistent with the standard.

In the sessions (“sk” and “none”), the volunteers did not wear sufficient clothing and their initial mean skin temperature ($\theta_{sk,m}$) was lower than that of the volunteers in the other system configurations (see figure 4.2). As a result, the mean thermal sensation vote at the beginning of the sessions was lower than “slightly cool” (-1), see figure 4.4).

This method seems useful to determine the mean thermal sensation of a group of people at the **beginning** but not at the end of the measurement session. Also in this standard, the time effect is not taken into account. The mean thermal sensation for all configurations decreased with time as shown in figure 4.4.

4.4.2.2 Mean skin temperature

In addition to the calculation method for the IREQ indices, some physiological criteria are suggested. One of these criteria concerns the mean skin temperature. The minimum mean skin temperature ($\theta_{sk,m}$) corresponding to the thermal status specified for IREQ_{min} is 30°C, and the $\theta_{sk,m}$ for IREQ_{neut} can be calculated according to

$$\theta_{sk,m} = 35.7 - (0.0285 M), \quad (4-2)$$

where M is the metabolic rate. In the climate room situation, $M=75W/m^2$ thus the minimum mean skin temperature corresponding to IREQ_{neut} equals 33.6°C. For all subjects, the measured mean skin temperature ($\theta_{sk,m}$) was lower than 33.6°C (thermoneutral conditions) from the beginning of the experiment because they were pre-cooled in a room where the air temperature was approximately 13°C. Figure 4.2, shows the mean skin temperature averaged across subjects in sessions with the same heating system configuration. Only for the configuration “none” the mean skin temperature drops below the 30°C limit, after a period of about 45 minutes. According to the standard, this results in a mean thermal sensation vote lower than -1 (“slightly cool”). For the other configurations, mean thermal sensation votes of -1 (“slightly cool”) or higher are expected based on the criterion given by this standard. On the basis of this criterion, we can conclude that the influence of the local heating system on the human thermal comfort is positive.

When the predicted and measured mean skin temperatures are compared, the mean TSV (figure 4.4) should be at least -1 (“slightly cool”), except for the configuration “none” towards the end of the testing period (see figure 4.2). This prediction does not hold for the configurations 'none' and 'sk', where the mean TSV at the end of the measurement is rated lower than -1 (“slightly cool”).

Holmér [Holmér 2004] states that mean skin temperatures lower than $(35.7 - 0.0285 * M)^\circ\text{C}$ might be accepted when a relatively homogeneous skin temperature is established. One reason might be that people accept significant local cooling if they perceive that their central body parts are comfortable.

4.4.2.3 Local thermal comfort

To assess the local comfort, ISO/TR 11079 refers to ISO 7730. In addition, the minimum hand temperature is defined as a local, physiological criterion. This is a relevant parameter in this research study.

Hand temperature

The minimum skin temperature for the hands to maintain a thermally neutral state of the body specified in ISO/TR 11079 – corresponding with $IREQ_{\text{neut}}$ – is 24°C . The minimum hand skin temperature for $IREQ_{\text{min}}$ is 15°C , in which condition peripheral vasoconstriction occurs. The left hand skin temperature of the volunteers in the experiments was measured. The lowest hand temperature measured at the end of the session was 18.8°C . According to the standard, all thermal sensation votes for the hand were expected to be -1 or higher. The actual thermal sensation votes do not support this statement, as only 53.5% of the volunteers (N=43) rated TSV as -1 or higher.

The volunteers' perception of thermal sensation might be more influenced by the temperature of the fingers, which was lower than the hand temperature. Therefore, the hand temperature might not be the most appropriate criterion to rate thermal sensation in such a cold environment.

4.5 Thermophysiological computer model

Within the Mechanical Department of the Eindhoven University of Technology, a thermophysiological model is being developed. This model which predicts human thermoregulation is an extension of the model of Fiala [Fiala 1998, Fiala et al. 1999], which is based on the model of Stolwijk [Stolwijk 1971]. In this

model, the human body is represented using a sphere for the head and cylinders for the other body segments (see figure 4.10). The body segments are divided into three sections: the anterior (front), posterior (back) and the inferior (inside). The inferior is used when two elements face each other. This division in sections enables the modelling of asymmetric boundary conditions (e.g. inhomogeneous radiant fields). The body elements exchange heat with each other via a central blood pool. All cylinders and the sphere are divided into five different layers: the core, the muscles, the fat, and the inner and outer skin, which all have different properties. Finally, each layer has one or several nodes.

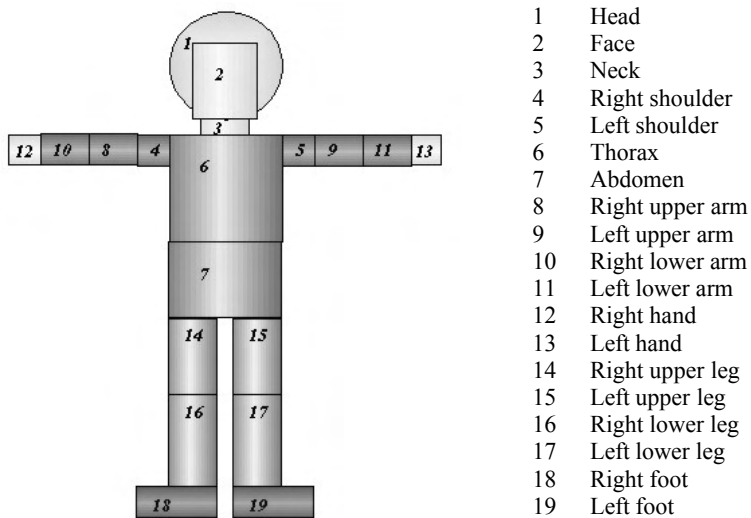

Figure 4.10. Schematic representation of the human body that is used in the model (picture according to Van der Meyden)

The dynamic model consists of a passive and an active part. The passive part models the heat transfer phenomena and heat redistribution within the body, including the thermal effects of blood circulation, heat generation in tissue layers, heat conduction and heat accumulation. The model interacts with the environment by convection, radiation, respiration, skin evaporation and water diffusion. The active part represents the actual thermoregulatory system. The body responds to temperatures and changes in temperature by extra heat production (shivering and metabolic heat production), sweating and vasomotion.

In the original model of Fiala the body segments were based on the 'average' man. This model is adapted in such a way, that the body elements can be adjusted according to mass, length and fat percentage of the modelled person [Marken Lichtenbelt et al. 2004; Frijns et al. 2006]. This way the model will be even more accurate, but in default mode, the model uses the body segments which are based on the 'average' person.

The thermophysiological model was mainly used to predict skin temperatures of patients in hospitals, who did not wear clothing. To be able to apply the model to the thermal situations in this PhD research, Obdam [Obdam 2004] implemented the modelling of clothing to the thermophysiological model, and modelling asymmetry was also enabled. This has been realized by splitting the body parts in a left and a right part (e.g. the body part 'arm' was split in a 'left arm' and a 'right arm'). After these adjustments, the human body consisted of 1 sphere for the head and 18 cylinders for the rest of the body as presented in figure 4.10. Van Pelt [Pelt 2005] added the possibility of modelling the various poses (sitting and standing) and the altering of the pose during the simulation period. A first attempt was made to implement the local radiant heating elements. This implementation was continued and verified by Van der Meyden [Meyden 2006] who also implemented the varying heat exchange when a person touches the relatively cold church bench.

The computer model is still under development, but first simulations have been conducted for this research. To verify the resemblance with reality, the results of the calculations are compared to the measurements that were conducted with the volunteers in the climate room. The model is used to calculate the skin temperature of a human being during a measurement session with the 'sbk' heating system configuration. The protocol followed in the measurements (pre-cooling period, entering the climate room and then alternately sitting, standing, etc.) was also calculated. For the calculation, the 'most average' volunteer (according to length, weight and not using any medication) was chosen from the measurement sessions. Figure 4.11 presents the comparison between the calculated and the measured mean skin temperature.

The overall temperature of the model at the beginning of the session, is higher than the temperature gained from the experiment. This is because in the model the person is in neutral thermal condition at the start, whereas the people in the climate room were not. At the start of the measurements, the volunteers rate their thermal sensation as 'slightly cool' (see figure 4.4), which means that their initial

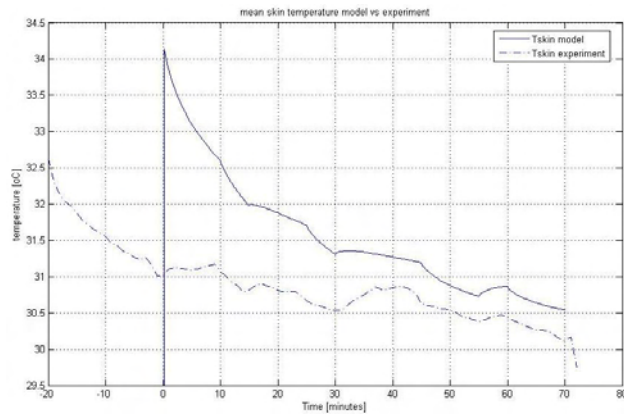

Figure 4.11. Mean skin temperature, computer simulation versus measurement. Volunteer entering the climate room at $t=0$, pre-cooling period is not calculated. (Figure created by Van der Meyden)

temperature was below the thermal neutral condition. The initial temperature of the model is adjusted to match the initial skin temperature at the start of the measurements, and the pre-cooling period is included in the modelling. Figure 4.12 presents the comparison between the simulation and the measurements. It shows a resemblance which looks quite well. The global trend of the mean skin temperature of the model matches the one of the experiment. The oscillations in the mean skin temperatures are mainly caused by a change in metabolism due to the alteration in position.

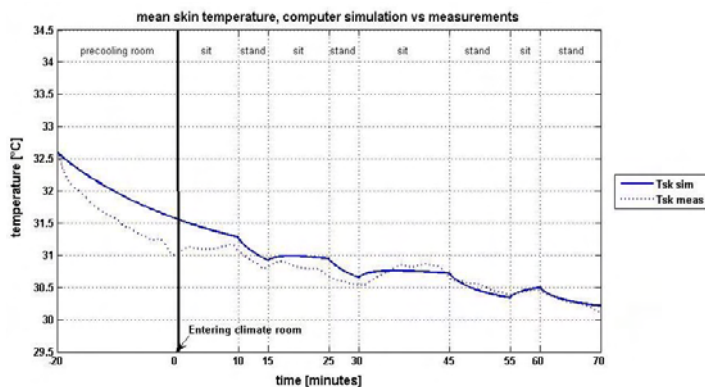

Figure 4.12. Mean skin temperature, computer simulation versus measurement. Volunteer entering the climate room at $t=0$, pre-cooling period is calculated too

4.6 Conclusions

4.6.1 Local heating system

The comfort study with volunteers showed that when more heating is applied to the benches, the temperature gradient over the human body increases less.

With the configurations 'sb' and 'sbk', the volunteers state that the thermal comfort level is 'slightly uncomfortable' to 'comfortable', so the aimed level of thermal comfort is reached. From the thermal preference vote and the decrease in thermal comfort vote, configuration 'sb' seems to perform even better than configuration 'sbk'. This might be explained by the mean skin temperature, which remains about the same in configuration 'sb' and decreases slightly in configuration 'sbk'. This might be related to the sensation of air movements which decreases in configuration 'sb', and slightly increases in configuration 'sbk'. The measurements indicate that the hands in particular, need to get more attention in the design of the heating system. The fingers cool down substantially, which influences the overall thermal sensation. No extra attention is needed for the feet (toes) since for all volunteers their foot temperature are almost all in the comfort zone.

4.6.2 Manikin

It is not possible to rate the human thermal comfort on the basis of the EHT measured with the help of our manikin (which only represents a human being as a heat source). A much more sophisticated thermal manikin that responds to its thermal environment, is needed.

4.6.3 ISO 7730

The most well known standard to evaluate general thermal sensation, ISO 7730, can be used to compare the effect of the different heating system configurations under the cold church conditions.

It is not advisable to use this method to determine whether a certain system meets the requirements for thermal comfort, because the outcomes are very sensitive to (partly estimated) input values. This implies, that individual deviations from a predicted mean value might be considerable. Also, the PMV is a static value whereas the results from the questionnaires clearly show that the thermal sensation vote is dynamic, i.e. decreases with time.

4.6.4 ISO/TR 11079

ISO/TR 11079 explicitly focuses on cold environments, and should therefore be suitable for this case study. Based on the results of this study, it is not possible to make a strong statement with respect to the applicability of the clothing's thermal insulation as a reliable indicator for thermal sensation.

To use the physiological criteria specified in ISO/TR 11079, i.e. the hand temperature and the mean skin temperature, data from measurements or a detailed model have to be available.

The lower initial mean skin temperatures for the configurations "seat, knee" and "none" (figure 4.2) result in a lower mean thermal sensation (figure 4.4) than for the other two configurations. This supports the opinion that thermal sensation is governed by the physiological status of the body rather than the thermal environment.

4.6.5 Measurements with volunteers

Using the questionnaire [ISO 10551:1995] provides some information about the thermal sensation and the thermal comfort of the volunteers. But, to evaluate the local thermal comfort under these relatively cold conditions, more specific questions on draught, vertical temperature gradient and radiant asymmetry should be added.

For future research, it is recommended to perform such measurements with more volunteers simultaneously. Then, also differences in the local climate between the various positions in the benches could be investigated. From the statistics standpoint, a larger population is preferred.

Whereas in this research only the skin temperatures on the left side of the body were measured, it is preferred to measure them on both sides of the human body, in order to investigate asymmetry.

The personal details of the volunteers, like length, weight, etc. should be measured and not specified by the volunteers themselves.

4.6.6 Thermophysiological computer model

The first results of the computer simulations with the thermophysiological model look promising. However, the model is still under development and more research is needed to verify the application of the model. In the future, this might be a very nice tool to predict the human thermal sensation.

5

Numerical simulations

5.1 Introduction

In chapter 3 and 4, measurements that were used to investigate the performance (both regarding conservation and human thermal comfort) of the local heating system have been presented. In this research, there was the opportunity to conduct measurements both in a climate room as well as in a real church. However, one cannot build a prototype for each situation, because this would be quite expensive and also difficult since every situation is different (different church, benches, heating system, etc.). Therefore, it would be ideal to use computer simulation tools for this kind of research. This chapter presents the results obtained with two simulation tools that calculate the indoor climate in the church and/or the climate room. The simulation tool HAMBASE is a whole building simulation model which rapidly calculates the mean indoor air temperature and relative humidity. This model has been used for the calculation of the overall indoor climate during a whole year when different heating strategies were used. However, we were especially interested in the indoor climate in the benches and in the temperature distribution over the height of the church. This required the use of a much more detailed simulation tool CFD (Computational Fluid Dynamics), which calculates temperatures and air flows as a function of place and time during one service. The applicability of the CFD tool Fluent for calculating the local indoor climate in the benches, is investigated in this research. In literature [Chen et al. 2001], directions are given for setting up a CFD model, and performing the verification and presentation of indoor environment modelling analyses. These directions have been followed in the present simulations.

5.2 CFD

The CFD program Fluent, release 6.2.16 [Fluent Inc. 2005] has been used to perform the simulations on a detailed scale (air flows, radiation temperature, air temperature and surface temperatures). This program enabled performing computer simulations of: a) the local indoor climate in the benches, and b) the overall indoor climate in the church.

While trying to model a church with a local bench heating system, several problems were encountered. First of all, the required computational capacity (memory and Hard Disk space) and computational time exceeded the maximum available values. Secondly, the complete verification of the church model (including the benches with the local heating system) could not be performed due to a lack of sufficient measurement data. Therefore, the problem has been simplified to a more manageable size: three benches with the local heating system were placed in a climate room where the boundary conditions could be controlled. For this climate room situation, it was possible to build a simulation model in CFD and to verify this model with the help of measurements.

First, an investigation on how the local bench heating system should be modelled in CFD, and what physical models should be used for performing these calculations, was performed. The local climate in the benches has been calculated and a verification with the climate room measurements was conducted. After that, the model was used to perform a variant study, in which a solution was sought for decreasing the risk of draught in the benches. The CFD results were used as boundary conditions for the thermophysiological model, which is explained in section 4.5. With this model, the resulting human skin temperatures have been calculated. Finally, a first attempt has been made to upgrade to the real (complex) situation in the church. Simulations of the church with several church benches equipped with the local radiant bench heating system were performed to investigate the influence of the local heating system on the overall indoor climate in the church.

5.2.1 CFD model

When using CFD, it is very important to know what physical models should be used. There are several viscous and radiation models that can be applied. Depending on the complexity of the problem, more or less sophisticated models should be used to get accurate simulation results.

5.2.1.1 Geometry

A multi-grid CFD model was built, in which a model of 3 church benches (model A) and a model of the climate room (model B) are merged into one as presented in figure 5.1. Model A consists of an unstructured grid of small grid cells with sizes increasing from 0.5cm near the heating elements and the benches to about 3cm at the interfaces/boundaries of the sub model. Model B consists of a structured grid, containing larger grid cells that grow in size from 3cm at the interface with model A, to a maximum size of about 20cm. The idea behind the multi-grid model was to first verify the proper modelling of the local heating system (in the bench area) in the climate room set-up. Then, since the required physical models are known, it should be possible to apply this verified bench model (model A) in the CFD geometry of the whole church (model C).

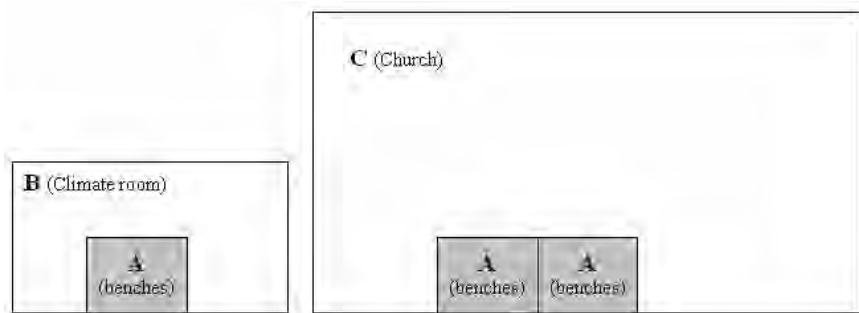

Figure 5.1. Multi grid approach. Left: bench model (A) merged with the climate room model (B). Right: bench model (A) merged four times (2 behind each other and 2 alongside) to the church model (C)

The multi grid model of the climate room situation (A+B) consists of 670,000 grid cells, whereas that of the church contains approximately 1,600,000 grid cells. Figure 5.2 presents the grid cell distribution as well as a picture of the according set-up in the climate room.

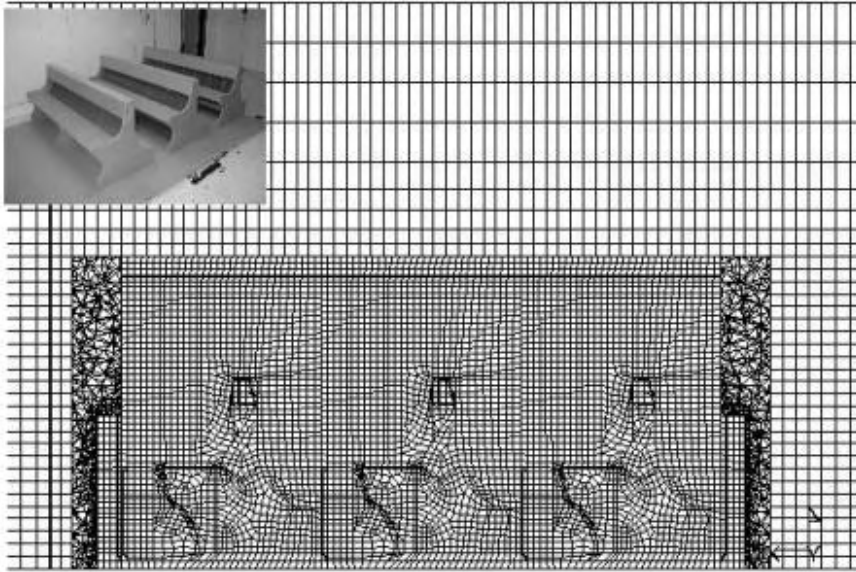

Figure 5.2. Grid cell distribution of the multi grid model of the benches in the climate room (Model A+B). Top left: picture of climate room set-up

Because the heat was not introduced by forced ventilation, but by radiation and natural convection from the heating elements, the Boussinesq approximation was used for the air density. For the most natural-convection flows, applying this Boussinesq approximation leads to a faster convergence than by setting up the problem with the fluid density as a function of the temperature.

The heating elements investigated in this study were implemented by imposing their measured temperatures as a fixed temperature in the CFD calculations.

5.2.1.2 Solver

In case of buoyancy driven air flows, the coupled implicit solver is recommended, but this requires 1.5 to 2 times as much memory as the other available solvers. However, when the use of the coupled implicit solver is desirable but the available memory is limited, the segregated or coupled explicit solver could be used instead. Since the “fixed temperature” option (which has been used in this thesis to model the local heating elements) is only available when using the segregated solver, this segregated solver is used in the present simulations.

5.2.1.3 Turbulence modelling

In order to select the most appropriate viscous model, the type of flow (either laminar or turbulent) that is present in this situation must be determined. The factor which determines the type of flow is the ratio of inertia forces to viscous forces, expressed by the non-dimensional Reynolds number:

$$Re = \frac{\rho u_a L}{\mu}, \quad (5-1)$$

where ρ is the air density, u_a is the air velocity magnitude, μ is the dynamic viscosity, and L is the characteristic length for the flow in the bench area.

For Reynolds numbers up to 2000 the flow is laminar and one could suffice with applying a laminar model for calculating the air flows. Beyond 4000, the flow is completely turbulent. In the climate room situation ($\rho = 1.265\text{kg/m}^3$ for air with a temperature of approximately 6°C and at a pressure of 1 atmosphere, $u_a = 0.1\text{m/s}$, $\mu = 1.7894\text{e}^{-5}\text{kg/ms}$, and $L = 0.5\text{m}$) the Reynolds number is about 3500, thus the flow is in transition between laminar and turbulent, and it is possible to find subregions of both flow types within the given flow field. This means that, in order to get sound results (which also include the turbulent effects) from the CFD calculations, a turbulence model has to be applied.

From literature [Chen et al. 2001] it is recommended to start with, for example, the standard k- ϵ model [Launder and Spalding 1974]. This model is generally applied in CFD analyses of the indoor environment. It is a simple and popular turbulence model which has proven to give accurate results for indoor air flow calculations.

A possible alternative to the standard k- ϵ model is the RNG k- ϵ model, which is a refined version of the standard k- ϵ model, derived using a rigorous statistical technique (called Renormalization Group theory). It has an additional term R_ϵ in its ϵ -equation (see equation 5-4) that improves the accuracy of rapidly strained flows. While the standard k- ϵ model is merely a high-Reynolds-number model, the RNG theory is expected to better account for low-Reynolds-number effects. This should make the RNG k- ϵ model more accurate and reliable for a wider class of flows than the standard k- ϵ model. Both models are applied in this thesis and are verified with measurement results to check which one performs best in this situation. In Fluent 6.2 [Fluent Inc. 2005], both the standard k- ϵ model and

the RNG k- ε model are available. The next section presents the equations that have been used when applying these turbulence models in the CFD calculations. In both the standard k- ε and the RNG k- ε model, the Boussinesq hypothesis is used which relates the Reynolds stresses to the mean velocity gradients [Fluent Inc. 2005]. Furthermore, this Boussinesq hypothesis assumes the turbulent viscosity, μ_t , to be an isotropic scalar that is computed as a function of k and ε according to the equation:

$$\mu_t = \rho C_\mu \frac{k^2}{\varepsilon} \quad (5-2)$$

where μ_t is the turbulent viscosity, ρ the density, C_μ is a constant, k is the turbulent kinetic energy and ε its dissipation rate.

The turbulent kinetic energy k , and its dissipation rate ε are obtained from the following transport equations:

$$\frac{\delta}{\delta t}(\rho k) + \frac{\delta}{\delta x_i}(\rho k u_i) = -\frac{\delta}{\delta x_j}(\Gamma_k \frac{\delta k}{\delta x_j}) + G_k + G_b - \rho \varepsilon \quad (5-3)$$

and

$$\frac{\delta}{\delta t}(\rho \varepsilon) + \frac{\delta}{\delta x_i}(\rho \varepsilon u_i) = -\frac{\delta}{\delta x_j}(\Gamma_\varepsilon \frac{\delta \varepsilon}{\delta x_j}) + C_{1\varepsilon} \frac{\varepsilon}{k}(G_k + C_{3\varepsilon} G_b) - C_{2\varepsilon} \rho \frac{\varepsilon^2}{k} - R_\varepsilon \quad (5-4)$$

where u_i is the (mean) velocity component, Γ_k and Γ_ε are diffusion coefficients, $C_{1\varepsilon}$, $C_{2\varepsilon}$, and $C_{3\varepsilon}$ are constants, G_k and G_b respectively represent the generation of turbulent kinetic energy due to the mean velocity gradients and due to buoyancy, and R_ε is an additional source term in the dissipation rate transport equation of the RNG k- ε model. t indicates time whereas x_i is the coordinate axis (x,y,z).

The generation of turbulent kinetic energy (k) due to mean velocity components is modelled identically for both the standard and the RNG k- ε model, and is defined as:

$$G_k = \mu_t \left(\frac{\delta u_i}{\delta x_j} + \frac{\delta u_j}{\delta x_i} \right) \frac{\delta u_i}{\delta x_j}, \quad (5-5)$$

The generation of turbulent kinetic energy due to buoyancy is given by:

$$G_b = \beta g_i \frac{\mu_t}{Pr_t} \frac{\delta T}{\delta x_i}, \quad (5-6)$$

where β is the thermal expansion coefficient, g_i is the component of the gravitational vector in the i th direction, Pr_t is the turbulent Prandtl number for energy, and T is the temperature.

The differences between the standard k-ε model and the RNG k-ε model as used in this thesis are:

- In the standard k-ε model, the diffusion coefficients Γ_k and Γ_ε are described by:

$$\Gamma_k = \mu + \frac{\mu_t}{\sigma_k}; \Gamma_\varepsilon = \mu + \frac{\mu_t}{\sigma_\varepsilon}; \sigma_k = 1.0; \sigma_\varepsilon = 1.3, \quad (5-7)$$

where σ_k and σ_ε are the turbulent Prandtl numbers for k and ε respectively.

In the RNG k-ε model, the diffusion coefficients Γ_k and Γ_ε are described by:

$$\Gamma_k = \Gamma_\varepsilon = \alpha \mu_{eff}; \mu_{eff} = \mu + \mu_t, \quad (5-8)$$

where μ_{eff} is the effective viscosity, and α is the inverse effective Prandtl number which is computed using the following equation:

$$\left| \frac{\alpha - 1.3929}{\alpha_0 - 1.3929} \right|^{0.6321} \left| \frac{\alpha + 2.3929}{\alpha_0 + 2.3929} \right|^{0.3679} = \frac{\mu}{\mu_{eff}}, \quad (5-9)$$

where $\alpha_0 = 1.0$ for the k and ε transport equations.

- There is a difference in the turbulent Prandtl number that is used to calculate G_b ; for the standard k-ε model $Pr_t = 0.85$, whereas for the RNG k-ε model, $Pr_t = 1/\alpha$, where α is computed by equation 5-9, but with $\alpha_0 = 1/Pr = k/\mu c_p$.
- The RNG k-ε model has an additional source term R_ε which is calculated by equation:

$$R_\varepsilon = \frac{C_\mu \rho \eta^3 (1 - \eta/\eta_0) \varepsilon^2}{1 + \chi \eta^3} \frac{1}{k}, \quad (5-10)$$

with,

$$\eta = S \frac{k}{\varepsilon}; S = (2S_{ij} S_{ij})^{0.5}; S_{ij} = \frac{1}{2} \left(\frac{\delta u_i}{\delta x_j} + \frac{\delta u_j}{\delta x_i} \right), \quad (5-11)$$

where S_{ij} is the mean strain rate, $\eta_0 = 4.38$, and $\chi = 0.012$

- The values of the constants $C_{1\varepsilon}$, $C_{2\varepsilon}$, $C_{3\varepsilon}$, and C_μ are different: for the standard k-ε model they have the values: $C_{1\varepsilon} = 1.44$, $C_{2\varepsilon} = 1.92$, $C_{3\varepsilon} = 1.0$, and $C_\mu = 0.09$. In the RNG k-ε model the following values are used: $C_{1\varepsilon} = 1.42$, $C_{2\varepsilon} = 1.68$, $C_{3\varepsilon} = 1.0$, and $C_\mu = 0.0845$.

5.2.1.4 Modelling radiative heat transfer

On the basis of personal discussions with experts from Fluent Inc. in Sheffield (UK), the Discrete Ordinates (DO) model was chosen for including radiative heat transfer from the local radiant heating elements to their environment in the

CFD simulations. Because the other available radiation models may over predict the radiative fluxes, the DO radiation model is probably the best suited for computing radiation from localized heat sources [Fluent Inc. 2005]. The DO model does not perform ray tracing, but transforms the radiative transfer function into a transport equation for radiation intensity in the spatial coordinates (x,y,z) . It solves as many transport equations as there are directions, with a solution method which is identical to that used for the fluid flow and energy equations.

5.2.1.5 *Wall functions*

In case of buoyancy-driven air flows, the standard wall functions are less reliable because the viscosity affected region near the wall is not resolved. Therefore, the enhanced wall treatment is recommended, in combination with an adequate mesh resolution in the near-wall region. The enhanced wall treatment is a near-wall model approach, in which the near-wall region is resolved all the way down to the wall [Fluent Inc. 2005]. This treatment however, requires a very fine mesh near the walls for which very large computing power is necessary. Therefore, the mesh near the heating elements (where the heat transfer from the elements to their surroundings is very important) is refined as much as possible (smallest grid cells near the wall is approximately 0.5cm). On the other hand, the grid cells near the outer walls of the climate room were kept at a quite coarse level in order to not exceed the available computer resources.

5.2.2 **Verification**

The standard k- ϵ model and the RNG k- ϵ model, both with the enhanced wall functions, were used to perform the first CFD simulations. In case of a buoyancy driven air flow problem, a steady state solution cannot be achieved. Therefore, transient computer calculations have been performed, with time steps of 5 minutes.

The room boundary conditions like wall, ceiling and floor surface temperatures as well as the initial surface temperatures of the benches were derived from the measurements in the climate room (chapter 3).

Verification of the CFD model is performed by comparing the results of the simulation with both quantitative and qualitative measurement results. Figure 5.3 presents the verification of the temperature distribution in the benches, by comparing the CFD results to the infra-red thermography. Since the infra-red

thermography shows a combination of the air temperature, surface temperature and the radiant temperature, all of these temperatures of the CFD simulations are presented. The figure shows a reasonable agreement between the temperature distribution in the measurements and the simulation results. Although there is only a slight increase in air temperature noted, the wooden floorboard and the mid panel of the bench are warmed substantially due to radiation from the seat heating element to these surfaces. These simulation results were derived using the standard k- ϵ model.

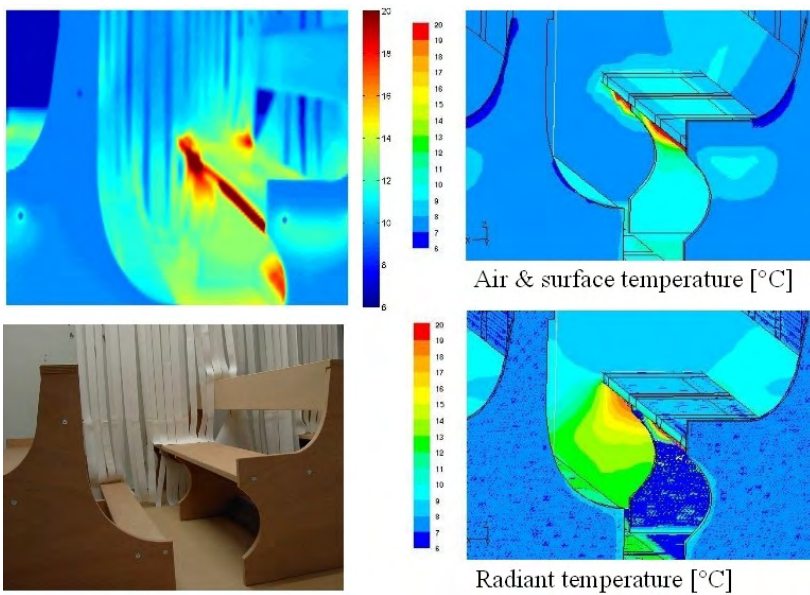

Figure 5.3. Verification of the temperature distribution: comparing CFD results (right) with the measured IR thermography (top left). The IR thermography is a combination of air, surface and radiant temperatures. Bottom left: photograph of situation

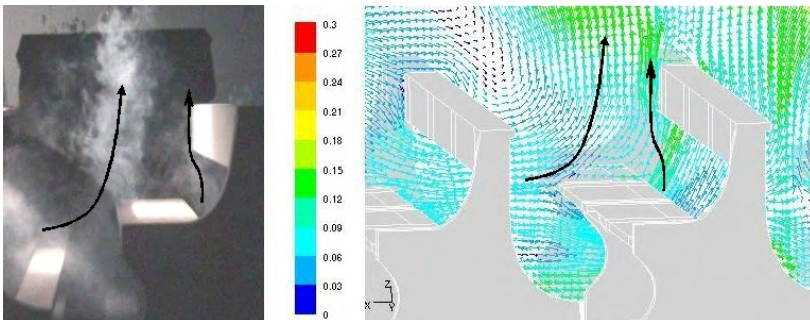

Figure 5.4. Verification of air flows: comparing CFD results (right) with smoke test (left)

In figure 5.4 the verification of the general air flow in the benches is presented by comparing the air flow from the CFD calculations with the results from the performed smoke tests. The figure shows a reasonable agreement between the CFD results and the measurement results obtained in the climate room set-up.

Besides the quantitative verification presented in the previous section, a qualitative verification has also been performed. To do this, the air velocity as well as the air and surface temperature on several horizontal and vertical lines through the bench area, have been compared to the measurement results presented in chapter 3. Figure 5.5 presents the comparison between the simulation results (obtained with different turbulence models) and the measurements on a vertical line. The verification of the temperature shows that all models give reasonable results. Detailed laboratory measurements [Grooten and de Vaan 2005] have shown, that the temperature sensors below the seat of the benches ($\leq 0.5\text{m}$) are influenced by the radiation from the seat heating element. This means that they measure a value which lies between the air and radiant temperature. Therefore, both the air and the radiant temperature are presented in figure 5.5. When looking at the verification of the air velocity, it is noticed that the RNG $k-\epsilon$ model does not predict the air velocity very well in this research. Although the measurements show an air velocity of about 0.15m/s above the bench area, the RNG $k-\epsilon$ model calculates a very low air velocity. The results from the standard $k-\epsilon$ model as well as the realizable $k-\epsilon$ model reasonably agree with the measurements. Because the standard $k-\epsilon$ model requires less computational resources, this model is used for further CFD calculations.

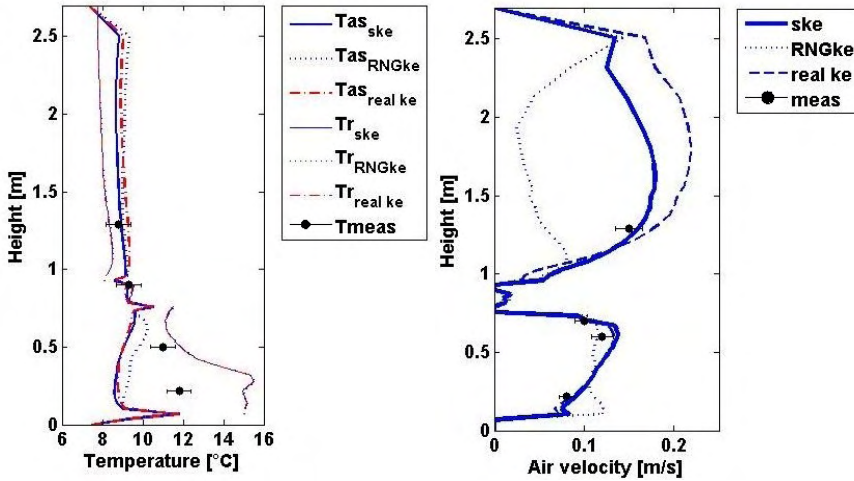

Figure 5.5. Verification of the temperatures and air velocities calculated using different turbulence models. Comparison with measurement results

5.2.3 Applying CFD in the climate room set-up

Verification with the measurement results has shown that the results from the CFD calculations give a reasonable representation of the actual situation. Based on the results of the comfort study (chapter 4), in which the risk on draught was noticed in the bench region, the CFD model has been used to investigate how the local climate in the benches could be improved. Since relatively cold air entered the bench area just above the wooden floorboard, a variant study has been performed to investigate whether this effect could be reduced by closing the bench area. Section 1.3 already mentioned choir stalls that are closed by side doors. Smoke tests have been performed in the climate room set-up to investigate the impact of closing the bench area on the air flow in the benches.

The bench area has been closed at the front, and up to different heights at the left and right side of the benches (see figure 5.6). In table 5.1:, the variants are explained in more detail.

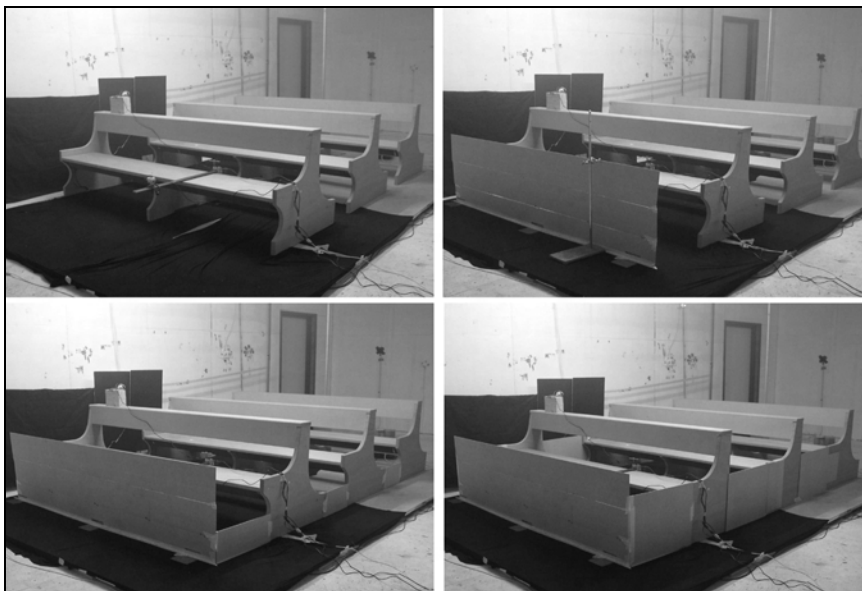

Figure 5.6. Photographs of variants: (top left) standard situation, (top right) variant 1, (bottom left) variant 3, (bottom right) variant 6

Table 5.1: Overview of the variants investigated (both in CFD as well as in the climate room set-up)

Case	Front closed	Height of the side panels [m]
Standard	no	-
Variant 1	yes	-
Variant 2	yes	0.11
Variant 3	yes	0.21
Variant 4	yes	0.37
Variant 5	yes	0.46
Variant 6	yes	0.57

When the bench area is open, a main air flow is visible, which enters the bench area at the front and, when the air is warmed up, rises out of the bench area just above the middle bench. Just above the wooden floorboard, smaller air flows are noticed which introduce turbulence areas in the first 30cm from the edge of the benches. When placing a closed panel in front of the benches, the main air flow from the front is obstructed. But, the air curls around this front panel and enters the bench area from the side (between the front panel and the first bench). A large air flow which is heading to the back of the bench area, is noticed along the side panels of the benches. The side panels placed in variants 2 and 3, do not

prevent the cold air to enter the bench area, but do increase the height at which the cold air enters (see figure 5.7).

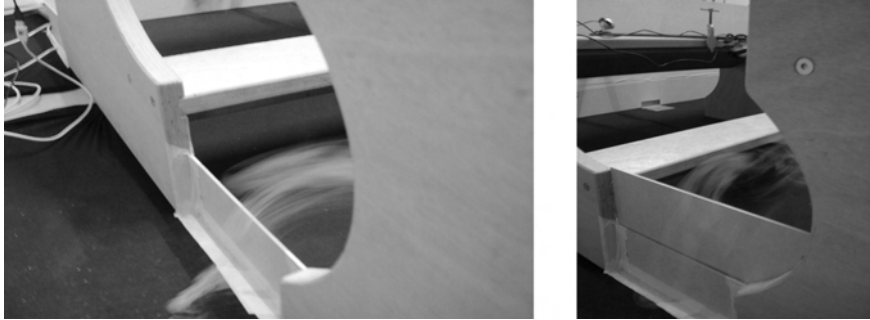

Figure 5.7. Air flow entering the bench area from the side. left: variant 2, right: variant 3

Only in variants 5 and 6, where the sides of the bench area are closed just beneath or just above the seat (0.46m and 0.57m respectively), the cold air is prevented to enter the bench area and introduce a turbulent region. In these situations, the cold air slowly merges with the air rising from the bench area. Because there is no air entering the bench area at a low level, the warmed air rises out of the bench area much slower. The smoke tests showed that the air remains in horizontal levels between the benches and slowly ascends from the bench area.

From these smoke tests, only the direction of the air flow was visible, but the air flow could not be related to the human thermal comfort. Therefore, the CFD model of the climate room set-up was used to investigate whether closing the bench area could reduce the air velocity and decrease turbulence. The air velocity and turbulence intensity are important for the perception of the human thermal comfort. Therefore, it is important to know these parameters around the people seated in the benches. The worst case for the thermal comfort of a person is when he or she is seated in the bench alone, and the air flows reach the person from all sides. In the CFD model, a person (represented by blocks as shown in figure 5.8) was placed on the middle bench. These simulations have been used just for analysing the environment around the person. The heat and moist production of the person itself is not taken into account in these simulations.

This variant study shows that, as expected, the radiant temperature in the bench area is almost not affected by closing the bench area. There is a slight increase in

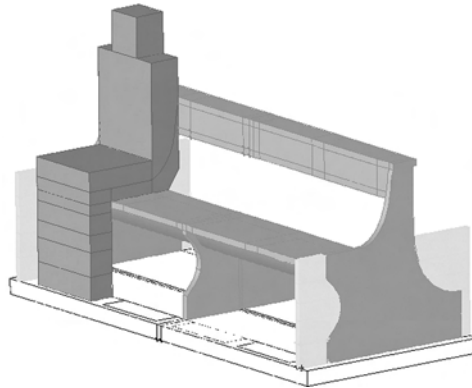

Figure 5.8. CFD geometry of one person which is placed on the middle bench. (For a good view of the person, the first and last bench are left out of the picture) The light grey areas represent the panels which close the bench area at the left and right side

radiant temperature because the view factors to the cold walls are reduced. The cold air is prevented from entering the bench area, thereby reducing the speed at which the warm air rises out of the bench. As a result, the air velocity in the bench area reduces and the air temperature increases slightly when the bench area is closed. The resulting indoor climate at an height of 0.215m in the bench area, is presented in table 5.2:.

Table 5.2: Local climate in the bench area at a height of 0.215m

Case number	Air temperature [°C]	Air velocity [m/s]	Turbulence intensity [%]
Standard	9.0	0.11	12
Variante 1	9.3	0.17	20
Variante 2	8.8	0.14	22
Variante 3	8.7	0.07	60
Variante 4	9.9	0.09	57
Variante 5	9.1	0.07	48
Variante 6	9.4	0.07	66

From these parameters, the draught risk could be calculated using equation 4-1. However, in section 4.4.1.3 we have already seen that this equation cannot be applied in this research due to differences in local climate and peoples' clothing and activity level.

The general expectation is that peoples' tolerance of air movements decreases when the temperature decreases. At the same air temperature, a lower turbulence level is expected to result in a higher comfort level. Since the air velocity in this

research is quite low (and even decreases in the variant study), the turbulence intensity (which is defined as the standard deviation of the air velocity divided by the mean air velocity) increases quite a lot. However, the smoke tests that were performed (see section 3.5.2) showed less turbulence between the benches which means a positive contribution to the human thermal comfort. As a result of this definition of turbulence intensity, it is not suited to rate the human thermal comfort.

In an attempt to relate the improvement of the local climate in the benches to the human skin temperatures, the results from the CFD calculations have been used as input parameters for the thermophysiological model mentioned in section 4.5. The air and radiant temperatures were specified for each individual body segment. Since it was not possible to specify the air velocity per individual body segment, the average air velocity (calculated from the air velocities near the individual body parts) was applied to the whole body. Since the air velocity shows the largest differences between the variants, this parameter has the largest influence on the skin temperatures which is visible in figure 5.9.

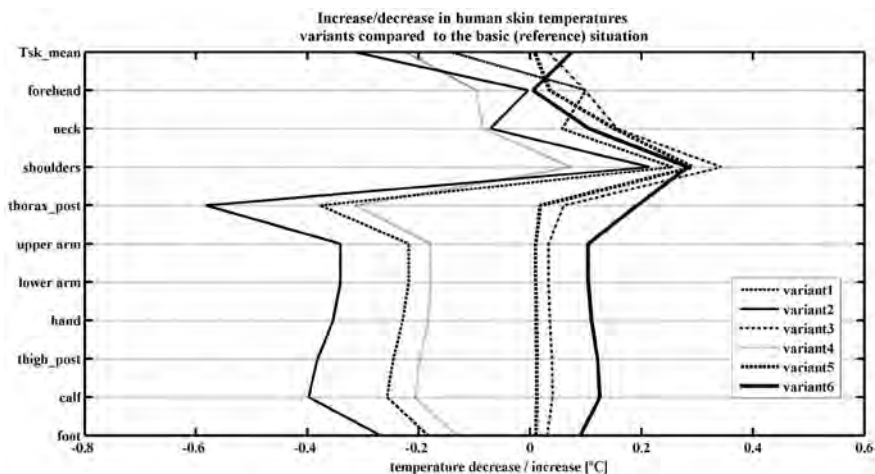

Figure 5.9. Increase in skin temperature in the different variants, compared to the standard situation

This figure presents the skin temperature increase/decrease of the individual body parts as they are calculated for the different variants, compared to the standard (reference) situation in which there are no panels applied. When closing

the benches by applying panels at the sides, the air velocities for the variants 1 and 2 increase, which result in a temperature decrease of the lower body. In the variants 3, 5 and 6, the air velocities decrease in the region below the seat (lower body) and show a slight increase near the upper body. This results in the same, or slightly increased skin temperatures compared to the reference situation. This approach could be very useful to calculate the effect of different local climates on the human skin temperatures, but only when the local climate can be applied for each individual body segment.

5.2.4 Applying CFD in the church of Rocca Pietore

5.2.4.1 Introduction

Apart from the in situ measurements that were performed in the church in Rocca Pietore [Camuffo et al, 2004], CFD simulations were used to investigate the possible improvement of the old heating system. After that, the influence of the (newly designed) local radiant bench heating system on the indoor climate in the church was investigated. The performance of this local heating system is compared to the performance of the original air heating system which was present in the church at the start of this research.

5.2.4.2 Air heating system

The first simulation of the church in Rocca Pietore was performed with the original air heating system as it existed at the start of the project. The air heating system in the church was operated for 3 hours. In figure 5.10, the temperature distribution as well as the air velocity in the church is presented. The picture shows that the hot air (about 70°C) that is blown into the church, immediately rises towards the vault and then spreads towards the back of the church. It shows large air movements from the air inlet towards the vault, and a small air flow which is introduced in the lower part of the church. A large temperature stratification is present; the region below the vault is heated up to approximately 30°C, whereas the area where the people are seated remains relatively cold (approximately 13°C). As already mentioned in section 1.2 and chapter 4, this is not a desirable situation. Neither for the conservation of monumental objects, nor for the human thermal comfort.

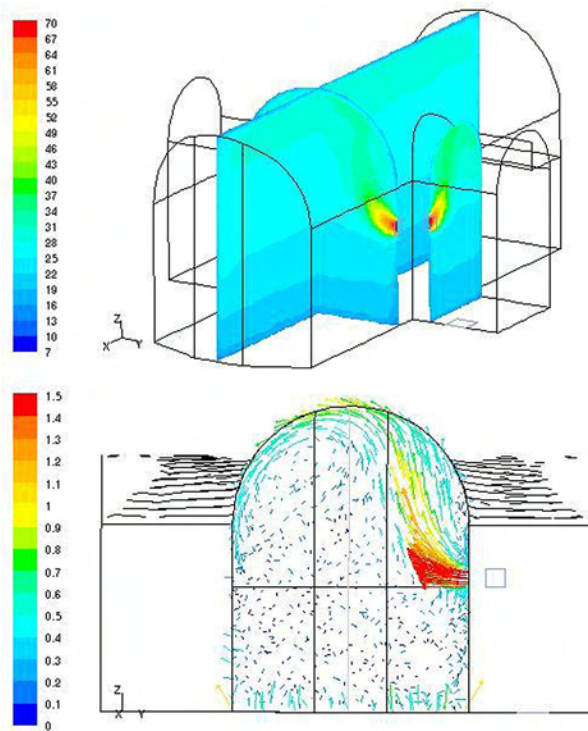

Figure 5.10. Temperature distribution [$^{\circ}\text{C}$] in the church (top) and the air velocity [m/s] in a cross section of the main nave, when applying the original air heating system ($Ar=0.66$)

5.2.4.3 Local radiant heating system

After the CFD calculations of the original air heating system, a first attempt has been made to calculate the indoor climate in the church of Rocca Pietore when the local radiant bench heating system is operated. For this, the verified bench model with the three benches (model A) is placed 4 times in the church model (model C) (see figure 5.11) and, as a result, the church is equipped with 12 benches. This combined model consists of 1,600,000 grid cells which turned out to be about the maximum size that could be managed by our computer facilities. When more benches were added to the church model, the program exceeded the available memory, thus the model could not be processed. Despite the limited amount of church benches in the church, the results do give an idea about the influence of the local radiant heating system on the overall indoor climate. As figure 5.12 presents, the air temperature in the bench area and in the rest of the

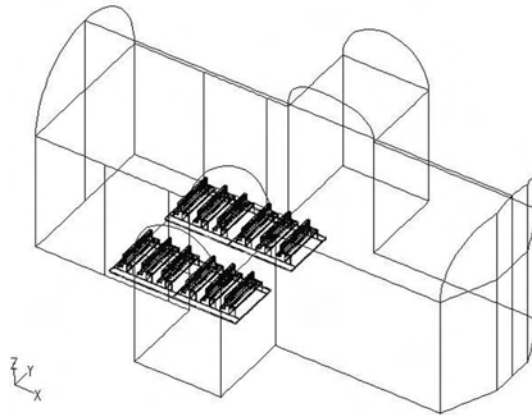

Figure 5.11. CFD model of the church of Rocca Pietore, the verified bench model (with 3 benches) is placed 4 times in the church model, thus creating a situation with 12 benches in the church

church is only warmed slightly. There is no large temperature stratification over the height of the church which indicates that, regarding the conservation of the interior objects and the building, this local system would be safe. It minimizes the risk of damaging the objects in comparison with the original air heating system. Although the air in the benches is only slightly warmed, this does not mean that the situation in the benches will be uncomfortable; the local heating system (radiant temperature) provides a certain level of thermal comfort.

Since the area in front of the benches is large, and the warmed air ascends out of the bench area at the back of the church, a circulating air flow is introduced. The indoor air cools down and descends in the front of the church, and is subsequently forced backward beneath and over the bench area by this general air flow. An increased air velocity is present underneath the benches and immediately after the last bench, where the warmed air emerges from the bench area. This increased air velocity might lead to draught perception, and has to be kept in mind with regard to the human thermal comfort. In reality, another block of six benches is located in front of the ones calculated in this simulation. However, these blocks are placed at a distance of about 2 meters from each other, which is enough for the warm air to rise up at the back of the first bench area, and for the cold air to enter the second bench area. In this second bench area, there is also cold air entering which emerges from the side transepts where no heating is applied (see figure 5.13).

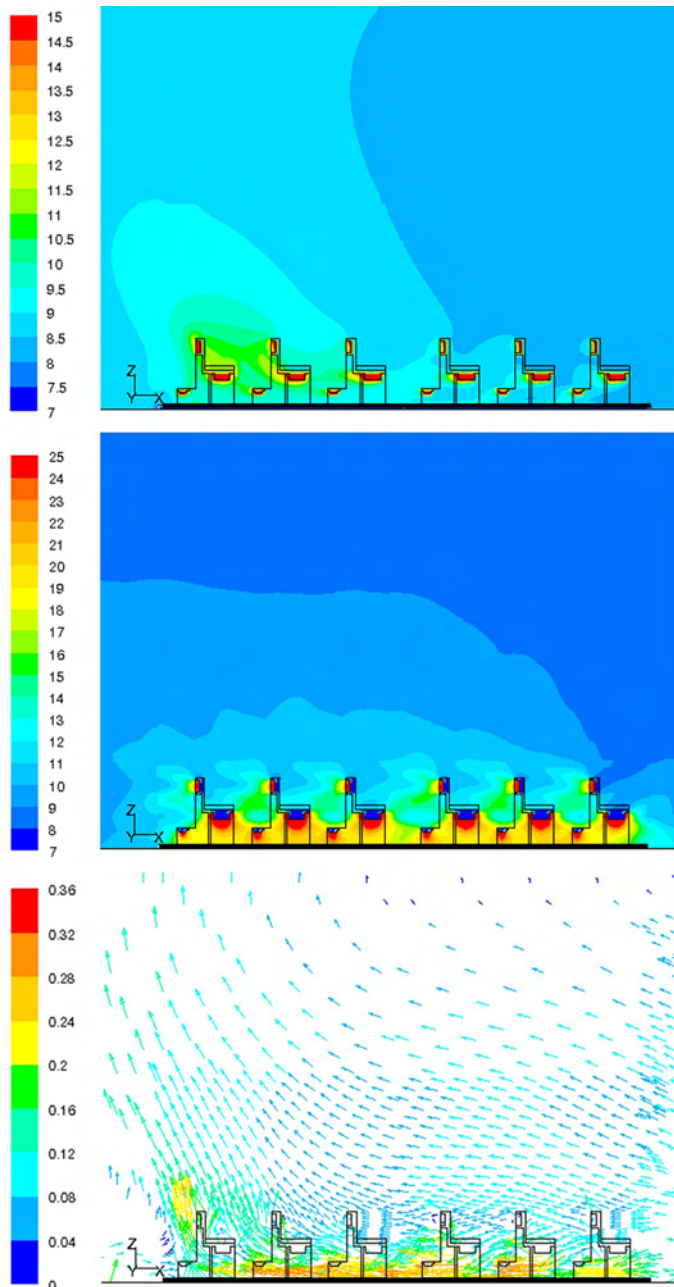

Figure 5.12. CFD results of the church with 2 rows of each 6 benches, equipped with the local radiant bench heating system. Top: air and surface temperature [$^{\circ}\text{C}$], middle: radiant temperature [$^{\circ}\text{C}$], bottom: air velocity [m/s]

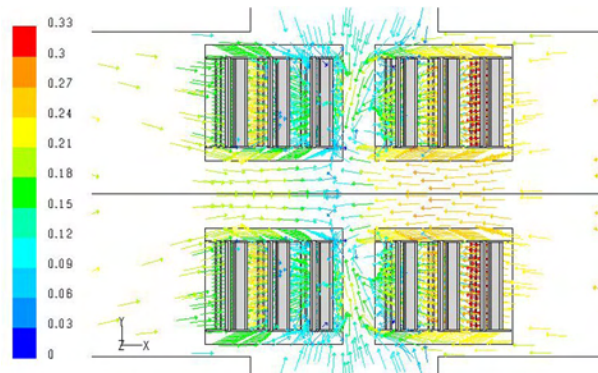

Figure 5.13. Horizontal cross section through the bench area in the church. Cold air emerges from the side transepts and enters the 2nd block of benches.

5.3 HAMBASE: hygrothermal building simulation tool

The other simulation tool used in this research is the hygrothermal simulation model HAMBASE [Wit 2006] which is written within the MatLab programming environment [Mathworks 2002]. This model calculates 1-D heat and vapour transmission in walls to estimate the indoor climate (temperature and relative humidity) relatively fast. On the basis of a simplified model of the geometry, it is possible to simulate different heating strategies and calculate the corresponding energy consumption or the heating capacity that is necessary to reach the required indoor climate. Figure 5.14 presents an overview of the input and output parameters of the simulation tool.

The simulation results consist of air and surface temperatures, the temperatures in the construction, the relative humidity of the air and near the surfaces, energy consumption, heating capacity, and the heat losses due to ventilation and transmission. Also the heat gain by solar radiation is calculated. The temperature and the relative humidity is calculated at only one point for the entire indoor air volume of the church. These values represent the mean indoor climate.

In this present research, HAMBASE has been used to calculate the overall indoor climate (air temperature, surface temperatures and relative humidity) and provides information about the energy consumption of the heating systems. It has also been used to compare the temperature and relative humidity in the church and the energy consumption of the (existing) air heating system and the (newly designed) local heating system.

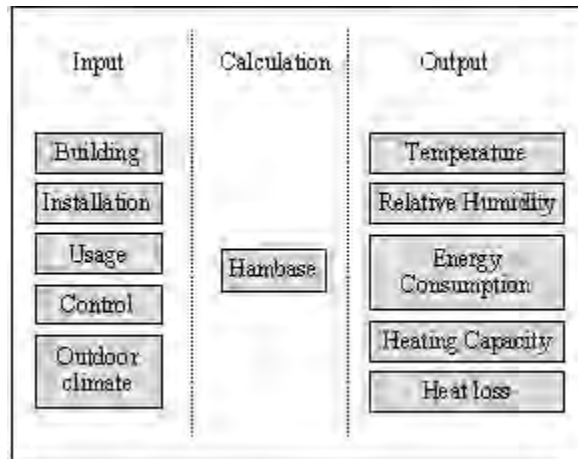

Figure 5.14. Overview of the simulation tool HAMBASE

5.3.1 Verification

To have confidence in the simulation results obtained from this research, the model is verified by comparing the simulation results with the results of the measurements that were conducted in the church of Rocca Pietore in Italy (see section 2.7.1). If there is a reasonable agreement between the simulation and measurements, the model is considered to be accurate enough, and can be used to predict future situations.

In figure 5.15, the simulated indoor air temperature and relative humidity for a week with services is presented. During these services the original air heating system is operated. The simulation results are compared with the measurements in the church. As the figure shows, the calculated temperature is in reasonable agreement with the measured one. There is a difference in relative humidity, caused by an uncertainty in the internal moisture production (the number of people present in the church was not recorded), but the tendency of the simulated relative humidity is the same as the tendency of the measured relative humidity.

Figure 5.16 presents the resulting temperature and the relative humidity near the surface of the walls and windows of the church. Whereas the indoor air is heated to about 20°C during a service, the indoor faces of the walls and windows reach a temperature of about 15°C. Due to the cold outdoor climate, the temperature of the windows decreases to a value between 0°C and 5°C.

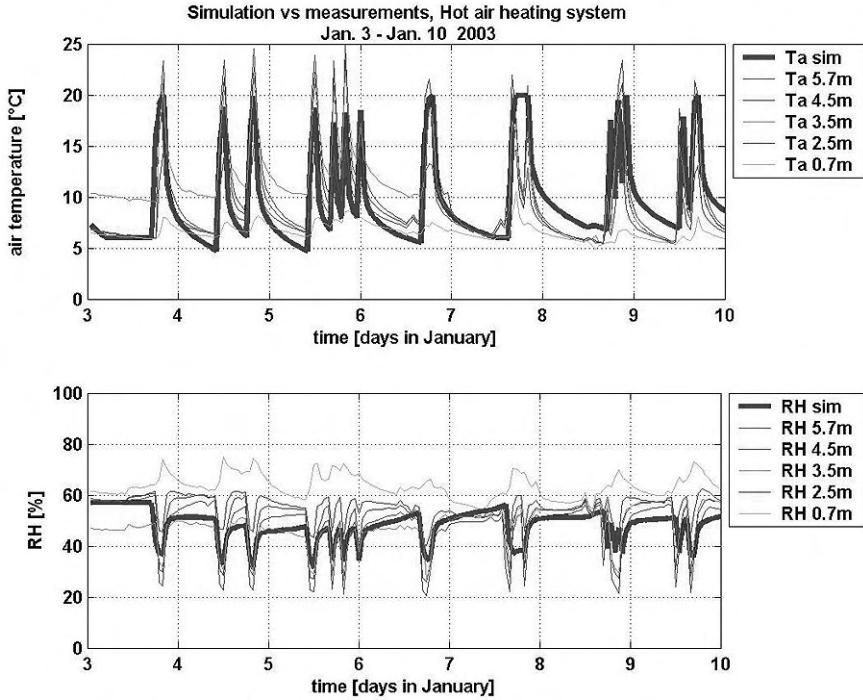

Figure 5.15. Comparing the simulated indoor climate to the measurements, when the air heating system is operated

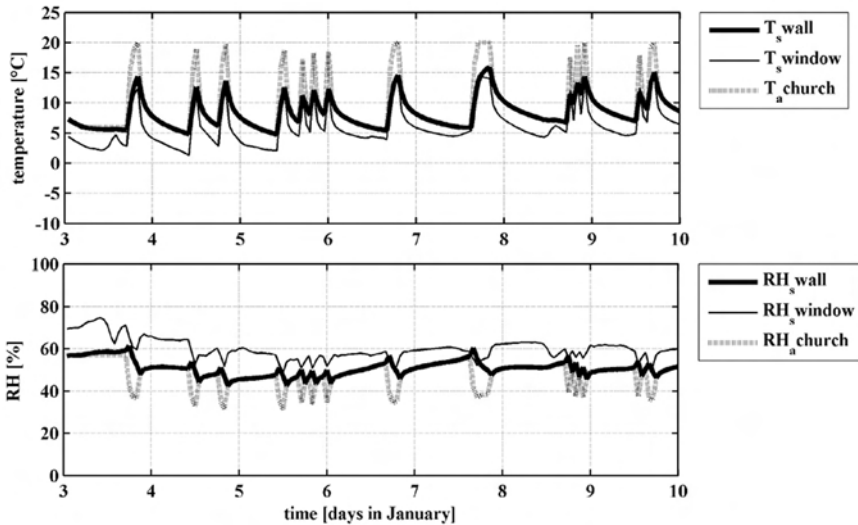

Figure 5.16. Calculated temperature and relative humidity of the indoor air, walls and windows during a one week period with services while operating the air heating system

Because the walls are quite thick (70cm), the temperature of their indoor faces does not drop below 5°C. The relative humidity of the indoor air in the church is about 55% to 60%, and drops below 40% when the air is heated. As a result, the relative humidity near the wall surfaces varies between 50% and 60%, and near the windows the RH varies between 60% and 75%. In section 1.2, we have seen that such RH cycles could cause damage to the building materials [Lubelli 2006].

The same simulation has also been performed for the situation with the local radiant bench heating system applied to all benches in the church. Since we do not have measurements of this situation at our disposal, only the simulation results are presented in figure 5.17. This figure shows that the fluctuations in indoor air temperature and the resulting relative humidity are much less than in the situation with the air heating system (figure 5.16). However, due to the lower temperatures, the relative humidity level increases: the air relative humidity varies between 50% and 60%. Regarding the influence on the building construction, shown in figure 5.18, the relative humidity near the wall surfaces is about 50% to 70% and regarding the windows, we can conclude that there is a risk of surface condensation because the relative humidity sometimes reaches 100%. Although the RH in the simulations reaches 100%, there were no traces of condensation noted on the windows of the church in Rocca Pietore. This might be explained by deviations in the hygroscopic behaviour of the building materials and the moist production, which are estimated parameters in the simulations. Still, one has to take this risk of condensation into account when applying a local heating system in another church or even another climate.

From these results, we can conclude that for the conservation of interior objects, the local heating system appears to be safer than the air heating system. However, one must not neglect the risk of surface condensation due to the high relative humidity near the cold surfaces. Another risk which remains, but is not investigated in this research, is the possible damage caused to the wooden church benches when the local heating system is applied.

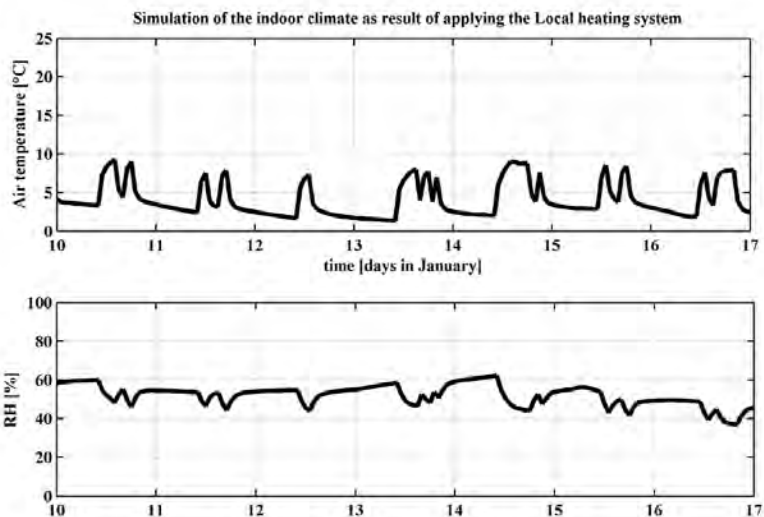

Figure 5.17. Simulated indoor climate of the situation in which the local radiant heating system is operated in all benches in the church of Rocca Pietore

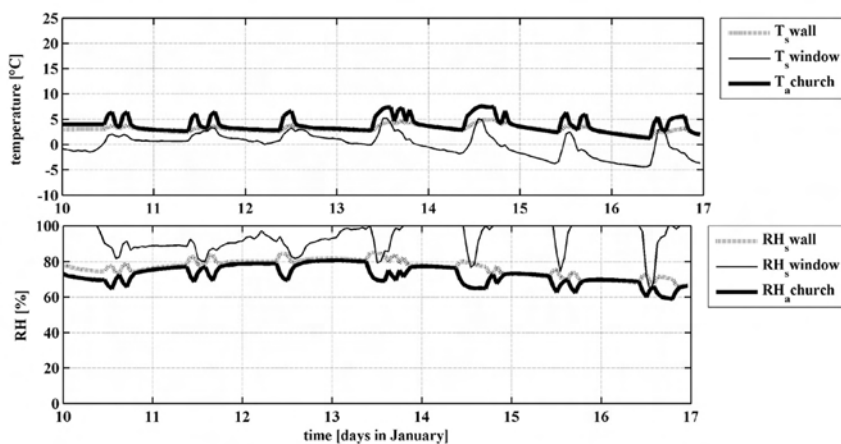

Figure 5.18. Calculated temperature and relative humidity of the indoor air, walls and windows during a one week period with services while operating the local heating system

5.3.2 Energy consumption

An advantage of the new local heating system, compared to the originally installed hot air heating system, is that the heating system can be operated for a shorter period of time (1 hour instead of 2.5 hours), and with a lower heating capacity. This should result in lower energy consumption. In table 5.3, the heating capacity and the calculated energy consumption during one week in the winter is presented for the two heating systems. When taking into account that the local heating system could be operated partially, i.e. not in all benches of the church, the energy consumption of this local heating system might be even lower.

Table 5.3: Heating capacity and energy consumption during one week in winter

Heating system	heating capacity [kW]	energy consumption during one week in winter [kWh]
air heating system	85	4140
local bench heating system	25	511

5.4 Conclusions

From this research we can conclude that there are several simulation tools that can be used with different levels of detail when performing an indoor environment study. HAMBASE is a suitable tool to perform global, whole building simulations. However, when information on a more detailed level is required, e.g. temperature distribution, air flow, etc., CFD turns out to be very useful.

The verification of the CFD results showed that the Standard k- ϵ model, in combination with the Boussinesq approximation and the DO radiation model provided reasonable simulation results. Although the RNG k- ϵ model was expected to perform better than the standard k- ϵ model, the results of this model were quite different from the measurements. A comparison of the air flows of the standard k- ϵ and the RNG k- ϵ model shows that when applying the RNG k- ϵ model, the 'buoyancy plumes' rise out of the bench area more quickly. However, the standard k- ϵ model does predict this air flow in accordance to the measurements.

The variant study showed that closing the benches at the front and at the side, prevents cold air from entering the bench area, thus reducing the air velocity and slightly increasing the air temperature in the benches. This might have a positive influence on the human thermal comfort, which is shown by the results of the thermophysiological model. When the bench area is closed up to 0.46m or 0.57m, the skin temperature of the lower body parts increases. However, the thermophysiological model does not (yet) take into account the turbulence intensity which is an important parameter for the perception of thermal comfort in such a cold indoor environment. On the other hand, people wear thick winter clothing including their coat, which reduces the skin area which is exposed to the indoor climate.

In the church in Rocca Pietore, the local radiant heating system appears to be a sound alternative for the “old” air heating system that heats the whole air volume of the church. First, the heating capacity of the local system is lower than that of the churches hot air heating system. Secondly, the local heating system only needs to be operated from 15 minutes before the service until the end of it, whereas the hot air heating system needs to be operated for several hours before the service starts. In addition, when only a few people attend the service, not all benches have to be heated with the local heating system. Therefore, the energy consumption of the local bench heating system will be importantly lower than that of the hot air heating system.

From the viewpoint of conservation, it is positive that the air between the benches, and also in the whole church, is only heated very slowly and does not reach high temperatures. There are no abrupt variations in air temperature and relative humidity, so the hygroscopic effects are less and the risk of causing damage to the monumental objects is minimized. Another advantage is that the stratification in air temperature above a height of about 2m, which existed when operating the hot air heating system, is not present with the local heating system. The heat is mainly present in the zone where the people are seated.

6

Conclusions and recommendations

6.1 Conclusions

6.1.1 Conservation of the church building and its interior objects

The first research question of this thesis was whether a local radiant heating system performs better, with regard to the conservation of a monumental building and its interior, than a heating system which heats the whole indoor air volume.

Both measurements and simulations of the indoor climate show that, in the church of Rocca Pietore in Italy, a local radiant heating system is much safer than the conventional air heating system regarding the conservation of the monumental interior and the church itself. The local heating system has almost no effect on the overall air temperature, and therefore, a minimal influence on the relative humidity. This (quite stable) indoor climate minimizes the risk on damaging the building and its interior (chapter 2).

Although there was no condensation on the windows of the church in Rocca Pietore during the measurements with the local heating system, the risk of condensation has to be taken into account. Particularly when applying a local heating system in another church, another outdoor climate, or when there is a larger internal heat and moist production by churchgoers. Since the walls remain relatively cold, the relative humidity near the cold surfaces could reach high levels, thus increasing the risk of surface condensation and/or mould growth.

A solution for this might be to use the original heating system to maintain a primary temperature of about 10°C during winter, and to use the local heating system as an additional system to create the comfortable situation for the people in the benches.

6.1.2 Human Thermal Comfort

The second research question was whether it is possible to realize a local heating system that is not only safe for conservation, but also meets the desired level of human thermal comfort (i.e. 'slightly cool')?

The thermal comfort study has shown that, although the influence of the local radiant heating system on the overall indoor climate is minimal, it does increase the level of human thermal comfort (section 4.2.3). The air temperature in the benches increases only a few degrees but, because of the radiant nature of the heating system, the surface temperature of the peoples clothes increases significantly. The heat is radiated to the people directly, without heating the air or the benches first. For the experiments with heating elements under the seat and in the back of the bench and for the experiments with an additional (third) heating element below the kneeler pad, it resulted in a comfort level of 'slightly uncomfortable' to 'comfortable', which equals the aimed level of thermal comfort.

The fingers, face and toes are usually the first to cool down. Of these body parts, the fingers and toes are quite important for the perception of the general thermal comfort. The comfort experiments conducted in the climate room, show that (in all tested heating configurations) the temperature of the feet and toes decreases, but still remains within the comfort zone. However, the finger temperature cools down much more and ends up in the uncomfortable zone. Further improvement of the local radiant heating system could be achieved by providing the fingers with more heat, thus increasing the finger temperature.

A drawback of introducing the heat locally in the benches is that it increases the air velocity and turbulence in the benches. This could lead to draught perception and excess cooling of the skin at the ankles and near the neck. Especially in such a cold indoor environment, where people are seated wearing a high clothing level and have a low activity level, this risk of draught perception has to be taken into account. The air velocities and turbulence intensities can be reduced by preventing the cold air to enter, and the warm air to rise from the bench area too quickly. The variant study presented in section 5.2.3, showed that closing the benches at the front and at the side, prevents cold air from entering the bench area, thus reducing the air velocity and slightly increasing the air temperature in the benches. This might have a positive influence on the human thermal comfort, which is shown by the results of the thermophysiological model.

International comfort standards

The ISO 7730 standard for evaluating the general thermal sensation should not be used under these cold circumstances because of the sensitivity of this standard to the deviations of the (partly estimated) input values (see table 4.6). In addition, the PMV is a static value whereas the results from the questionnaires in our comfort study clearly show that the thermal sensation vote is dynamic, i.e. decreases in time.

The ISO/TR 11079 is an international standard which focuses specifically on cold environments. It relates the clothing level (thermal environment) to the thermal sensation. However, the experiments show that the physiological status of the body rather than the thermal environment determines the thermal sensation.

Performing a thermal comfort study

The thermal comfort study conducted in the climate room shows that there are statistically significant correlations between the measured skin temperatures and the people's thermal sensation votes and thermal comfort votes. In addition, the results show three strong correlations between the heating system configuration and the TSV or TC votes: 1) for the TSV of the people's bottom, 2) for the TSV of their fingers, and 3) for the general TC vote and the heating system configuration.

There are indications from the comfort study that at some positions in the benches, the thermal comfort level is better than on others. Unfortunately, this could not statistically have been proven, due to the small amount of people simultaneously present in each measurement session.

Thermophysiological simulation model

The thermophysiological model of the Mechanical Department of the TU/e cannot yet predict the effect of the air flows and turbulence intensity on the human skin temperatures. Although the thermophysiological model is still under development, the comparison between the simulation results and the comfort measurements looks promising (see section 4.5).

6.1.3 Computer simulations for predicting the local indoor climate

The third research question was whether CFD can be applied for performing a variant study by predicting the local indoor climate in and around the church benches?

In chapter 5 of this thesis, simulation tools have been applied at different levels of detail in an indoor environment study. HAMBASE is a suitable tool to perform global, whole building simulations. But, when information on a more detailed level is required, e.g. temperature distribution, air flow etc., CFD appeared to be very useful.

The verification of the CFD results showed that the standard k- ϵ model, in combination with the Boussinesq approximation and the DO radiation model provided reasonable simulation results. Although the RNG k- ϵ model was expected to perform better than the standard k- ϵ model, in this study the results of the RNG k- ϵ model showed quite some deviation from the measurements. A comparison of the air flows of the standard k- ϵ and the RNG k- ϵ model shows that when applying the RNG k- ϵ model, the 'buoyancy plumes' emerged from the bench area more quickly than with the standard k- ϵ model which predicted this air flow in accordance to the measurements.

6.2 Recommendations

6.2.1 Conservation of the church building and its interior objects

The possibility of mounting the local heating system in different types of (monumental) church benches, pews etc. should be investigated. It is recommended to use insulated connecting pieces in order to not heat the bench too much (which could cause damage to the church benches).

The present thesis focussed only on the thermal climate in the bench area. However, the hygric climate and its effect on the interior objects and the church building has to be analysed to make sure that this does not introduce risks on damaging the building and its interior objects.

6.2.2 Human Thermal Comfort

Regarding the optimization of the local heating system, further improvement could be achieved by providing the fingers with more heat. The finger temperature has a strong influence on the overall sensation of thermal comfort.

The perception of draught in such cold environments where people are seated with a low activity level and a high clothing level needs further research. Existing standards rate only the draught perception in office environments where the temperature is much higher, or the wind chill factor in outdoor environments where the air velocities are much higher compared to the indoor environment in this research.

Performing a thermal comfort study

When performing a comfort study, a large group of volunteers should undergo the experiments simultaneously in order to have a population which is large enough for statistical evaluation. The personal details of the volunteers, like length, weight, etc. should be measured instead of specified by the volunteers themselves. Also, it is preferred to make sure the clothing level of all people is the same, because existing calculation methods such as the PMV, turn out to be quite sensitive to these parameters. This might be established by providing the people with the same clothing package.

The questionnaires as used in the ISO 10551 standard, provide some information about the thermal sensation and the thermal comfort of the volunteers. However, to evaluate the local thermal comfort under these relatively cold conditions, more specific questions on draught, vertical temperature gradient and radiant asymmetry should be included. To investigate the heating asymmetry, the skin temperature on both sides of the human body should be measured whereas in the present research the temperature was measured only on the left side.

6.2.3 CFD simulations for predicting the local indoor climate

Verification of the CFD model

For the verification of CFD models, a more detailed measurement set-up is recommended, with much more measurement positions for the air and surface temperatures, relative humidities and air velocities. For the latter, it would be nice to be able to apply techniques like particle tracking velocimetry (PTV) or particle imaging velocimetry (PIV).

CFD simulations

In this present thesis, CFD simulations were performed to calculate the local

indoor climate around one person in the benches. This is the “worst-case” scenario for human thermal comfort, as the cold air flow can reach the person from all sides.

It is also interesting to research the “worst case” scenario for the conservation of the building and its interior. This would be the situation in which all benches are completely filled with people, thus creating a maximum heat and moisture production in the church.

Another recommendation is to investigate whether it is possible to heat only those benches that are occupied by people. Is it enough to heat only one bench or should a block of benches be heated in order to create the thermal comfortable situation? How many benches should such a block comprise?

In this thesis, each heating element is implemented by modelling the element as one block and imposing a fixed temperature to its outer face. The heat transfer from the heating element to its environment could be investigated more in detail. It might also be very interesting to investigate how the grid (which protects the heating foil) influences the heat transfer from the element to its environment. These results could be used to optimize the design of the local radiant heating elements.

6.3 Recommendations for applying a local radiant heating system

Before applying a local heating system in a church, there are several things which have to be taken into consideration.

First of all, the criteria for the conservation of the building and its interior have to be determined. What are the criteria for the upper and lower boundaries and the changes in air temperature, relative humidity and air velocity? It is also important to know the existing indoor and outdoor climate and possible problems that are present (e.g. surface condensation, damage to the building or its interior objects).

Secondly, one has to know what level of thermal comfort level is required for the activities that take place in the church? What are the visitors used to? How are they dressed? etc.

For the thermal comfort of the people in the benches, the most important regions to provide the heat to, are the extremities (feet and hands). Cold air flows near the peoples neck and ankles should be prevented as this could cause complaints

about draught. Contact with cold surfaces of the benches should also be prevented as this could be perceived as very uncomfortable. A simple way to increase the contact temperature of the bench is, for example, to apply a layer of felt on the seat.

The lay-out of the benches determines where local heating elements could be installed. It is also very important to know whether it is permissible to mount local heating elements into the benches. For example, screwing the elements down to the benches, might be a problem when monumental benches are present in the church. In such a case, alternative ways of attaching the elements to the benches have to be investigated.

The positions where the heating elements could be attached to the benches does also depend on whether its allowed to see the elements., because local heating elements in the benches could have a large visual impact.

A building simulation tool (e.g. HAMBASE) could be used to estimate quickly what the savings on energy consumption could be when applying a local heating system.

A more detailed study on the indoor climate (both regarding conservation and human thermal comfort) could be made with a CFD package to investigate the resulting indoor climate without installing the local heating system in the church first. In this way, the most optimal heating configuration could be designed.

If the results are satisfying, the local heating system can be applied in the church benches.

References

- Adan, O.C.G., 1994: *On the fungal defacement of interior finishes*, Dissertation TU/e, Eindhoven, The Netherlands, ISBN: 90- 386- 0194-8.
- Arendt C., 1993: *Raumklima in Grossen Historischen Räumen*. Verlagsgesellschaft Rudolf Müller GmbH, Köln
- Arnold, A., Zehnder, K., 1991/1: *Monitoring Wall Paintings Affected by Soluble Salts*, S. Cather (ed.); *The Conservation of Wall Paintings*, Proceedings of a symposium organized by the Courtauld Institute of Art and the Getty Conservation Institute, London, July 13-16, 1987, The Getty Conservation Institute, Thien Wah Press, Singapore, p.103-135
- Arnold, A., Zehnder, K., Küng, A., Emmenegger, O., 1991/2: *Wandmalereizerfall, Salze und Raumklima in der Klosterkirche von Müstair*. Zeitschrift für Kunsttechnologie und Konservierung 5/91
- Bohm, M., Browén, A., Norén, O., Holmér, I., Nilsson, H., 1991: *Thermal environment in cabs*. Paper no 911565 of the 1991 International winter meeting of the American Society of Agricultural Engineers (ASAE), December 17-20, Chicago, Illinois
- Bordass, W., 1984: *Heating your Church*, CIO Publishing London, ISBN: 0- 7151- 7543- 2
- Bratasz, L., Kozłowski, R., 2005/1: *Laser Sensors for Continuous In-Situ Monitoring of the Dimensional Response of Wooden Objects*, Studies in Conservation, volume 50, p.1-10
- Bratasz, L., Jakiela, S., and Kozłowski, R., 2005/2: *Allowable thresholds in dynamic changes of microclimate for wooden cultural objects: monitoring in situ and modelling*, 14th Triennial Meeting of the ICOM Committee for Conservation, The Hague, The Netherlands, 12-16 September 2005, Volume 1
- Camuffo, D., Bernardi, A., 1995: *The Microclimate of the Sistine Chapel*, European Cultural Heritage Newsletter on Research, 9, p.7-33
- Camuffo, D., 1998: *Microclimate for Cultural Heritage*, Elsevier, Amsterdam

- Camuffo, D., Sturaro, G., Valentino, A., Camuffo, M., 1999/1: *The Conservation of Artworks and the Hot Air Heating System in Churches: Are they Compatible? The Case of Rocca Pietore, Italian Alps*. Studies in Conservation, 44, 3, p.209-216
- Camuffo, D., Sturaro, G., Valentino, A., 1999/2: *Thermodynamic exchanges between the external boundary layer and the indoor micro climate at the Basilica of Santa Maria Maggiore, Rome, Italy: the problem of conservation of ancient works of art*, Boundary Layer Meteorology, 92, p.243-262
- Camuffo, D., et al., (2006): *A practical guide to the pros and cons of the various heating systems with a view to the conservation of the Cultural Heritage in Churches*; Results of the European Project “Friendly-Heating” (EVK4-CT-2001-00067). A scientific support for activities of the European Standardisation Committee CEN/TC-346 WG4 “Conservation of Cultural Property”
- Chen, Q., Srebric, J., 2001: *How to Verify, Validate, and Report Indoor Environment Modeling CFD Analyses*, RP-1133, ASHRAE, American Society of Heating, Refrigerating and Air-Conditioning Engineers, Atlanta
- Chabot, L., Verdonchot, J.H.A., 2005: *Research on reducing draught when using a local bench heating system*, Report of Master project, Faculty of Architecture, Building and Planning, unit BPS, TU/e, Eindhoven, The Netherlands
- Enander, A., 1987: *Effects of moderate cold on performance of psycho motor and cognitive tasks*. Ergonomics, 30, p.1431-1445
- Fanger, P.O., 1970: *Thermal comfort*, Dissertation, Technical University of Denmark, Lyngby, Denmark
- Fiala, D., 1998: *Dynamic simulation of human heat transfer and thermal comfort*. PhD thesis, De Montfort University, Leicester, UK
- Fiala, D., Lomas, K.J., Stohrer, M., 1999: *A computer model of human thermoregulation for a wide range of environmental conditions: The passive system*, Journal of Applied Physiology, p. 1957-1972
- Fluent Inc., 2005: *Fluent 6.2 User's Guide*, Fluent, Lebanon
- Frijns, A.J.H., Limpens-Neilen, D., Schoffelen, M.E.A., van Leeuwen, G.M.J., 2006: *Simulations of the Human Thermal Response to Local Heating*. Conference paper on CD, Editors: R.N. Pikaar, E.A.P. Koningsveld, P.J.M. Settels, IEA2006 conference (International Ergonomics Association), Maastricht, The Netherlands

- Griefahn, B., 2000: *Limits of and possibilities to improve the IREQ cold stress model (ISO/TR 11079) - A validation study in the field*. Applied Ergonomics, Elsevier Science, ISSN: 0003-6870, Vol.31, p423-431
- Grooten, K.H.E., Vaan, C.F.M. de, 2005: *The influence of radiation on temperature sensors*, Report of Master project, Faculty of Architecture, Building and Planning, unit BPS, TU/e, Eindhoven, The Netherlands
- Holmér, I., 2004: *Cold but comfortable? - Application of comfort criteria to cold environments*, Indoor Air, Blackwell Munksgaard, ISSN 0905-6947, Vol.14, Issue 7, p27-31
- Huizenga, C., Hui, Z., Arens, E., 2001: *A model of human physiology and comfort assessing complex thermal environments*. Building and Environment, Elsevier Science, Vol. 36, Issue 6, p691-699, ISSN: 0360- 1323
- Huynh, C.K., Savolainen, H, Vu-Duc, T., Guillemin, M., Iselin, F., 1991: *Impact of Thermal Proofing of a Church on its Indoor Air Quality: the Combustion of Candles and Incense as a Source of Pollution*, Science of the Total Environment, 102, p.241-251
- ISO 10551:1995: *Ergonomics of the thermal environment - Assessment of the influence of the thermal environment using subjective judgement scales*, International Organization for Standardization, Geneva, Switzerland
- ISO 7726:1998: *Ergonomics of the thermal environment - Instruments for measuring physical quantities*, International Organization for Standardization, Geneva, Switzerland
- ISO 7730:2005: *Moderate thermal environments -- Determination of the PMV and PPD indices and specification of the conditions for thermal comfort*, International Organization for Standardization, Geneva, Switzerland
- ISO 8996:2004: *Ergonomics of the thermal environment - Determination of metabolic rate*. International Organization for Standardization, Geneva, Switzerland
- ISO 9920:1995: *Ergonomics of the thermal environment - Estimation of the thermal insulation and evaporative resistance of a clothing ensemble*, International Organization for Standardization, Geneva, Switzerland
- ISO/TR 11079:1993: *Evaluation of cold environments -- Determination of required clothing insulation (IREQ)*, International Organization for Standardization, Geneva, Switzerland
- Knol, H., 1971: *Kerkverwarming en Orgels*. Rapport in opdracht van de Vereniging van Kerkvoogdijen in de Nederlands Hervormde Kerk

- Kozłowski, R., Wittenburg, C., Zeunert, A., 2000/1: “*Stucco Marble in the Dukes Chapel in Krzeszow, Poland – microclimate and degradation mechanism*”, International Journal for Restoration of Buildings and Monuments; ISSN 0947 – 4498, 6 (4), p.463-480
- Kozłowski, R., 2000/2: “*Microclimate in the historic wooden church in Debno*”, Conservator-Restorers’ Bulletin, 11 (4), p.16-22
- Künzel, C., Holz, D., 1991: *Richtiges Heizen in historischen Gebäuden*. VDI Berichte nr. 896
- Lauder, B.E., Spalding, D.B., 1974: *The numerical computation of turbulent flows*. Computer Methods in Applied Mechanics and Energy, Volume 3, p.269-289
- Loomans, M.G.L.C., 1996: *Dantec 54R10-54N21(CTD) combination: calibration procedure and error determination*, FAGO internal report 96.66.S, TU/e, Eindhoven, The Netherlands
- Loomans, M.G.L.C., 1997: *Design of and discussion on a thermal mannequin*, FAGO internal report 97.16.K, TU/e, Eindhoven, The Netherlands
- Loomans, M.G.L.C., 1998: *The Measurement and Simulation of Indoor Air Flow*. Dissertation TU/e, Eindhoven, The Netherlands, ISBN: 90- 6814- 085- X
- Lotens, W.A., 1988: *Comparison of thermal predictive models for clothed human beings*. ASHRAE Transactions, part 1, page 1321-1340. Atlanta, USA. ISSN: 0001-2505
- Lubelli, B.A., 2006: *Sodium chloride damage to porous building materials*, Dissertation Delft University of Technology, ISBN: 90- 9020343- 5
- Marken Lichtenbelt, W.D. van, Frijns, A.J.H., Fiala, D., Janssen, F.E.M., Ooijen, A.M.J., and Steenhoven, A.A. van, 2004: *Effect of individual characteristics on a mathematical model of human thermoregulation*, Journal of Thermal Biology 29, p.577-581
- Mathworks, 2002: *MatLab version 6.5, User’s guide*
- McIntyre, D.A., 1980: *Indoor Climate*, London: Applied Science
- Meyden, T.J. van der, 2006: *Local heating in churches: simulations of the human thermal responses*, internal report number: WET 2006-18, Department of Mechanical Engineering, TU/e, Eindhoven, The Netherlands
- Obdam, T.S., 2004: *Friendly heating in churches*, internal report WET 2004-23, Department of Mechanical Engineering, TU/e, Eindhoven, The Netherlands
- Padfield, T., 1998: *The role of absorbent materials in moderating changes of relative humidity*, PhD thesis Series R no. 54, Department of Structural

- Engineering and Materials, Technical University of Denmark, ISBN: 87- 7740- 256- 1, ISSN: 1396- 2167
- Pallant, J., 2001: *SPSS Survival Manual – A step by step guide to data analysis using SPSS for Windows (version 10)*, 1st edition, Open University Press, Buckingham, ISBN: 0- 335- 20890- 8
- Pelt, S. van, 2005: *Local heating in churches: simulations of the human thermal responses*, internal report WET 2005-26, Department of Mechanical Engineering, TU/e, Eindhoven, The Netherlands
- Pfeil, A., 1975/1: *Kirchenheizung und Denkmalschutz: Wärmebedarf, Feuchtehaushalt, Heizungssysteme*. S.I. Bauverlag GMBG Wiesbaden und Berlin, ISBN: 376250651
- Pfeil, A., 1975/2: *Untersuchungen über das Raumklima sowie den Wärme- und Feuchtehaushalt in Kirchen alter Bauart und deren Einflüsse beim Einbau von Kirchenheizungssystemen*, Dissertation Technische Universität Braunschweig, Sofortdruck, Braunschweig, 195p.
- Sánchez-Moral, S., Soler, V., Cañaveras, J.C., Sanz-Rubio, E., Van Grieken, R., Gysels, K., 1999: *Inorganic deterioration affecting the Altamira Cave, N Spain: Quantitative approach to wall-corrosion (solution etching) processes induced by visitors*, Science of the Total Environment, 243/244, p.67-84
- Schellen, H.L., 2002: *Heating Monumental Churches; indoor climate and preservation of cultural heritage*, Dissertation TU/e, Eindhoven, The Netherlands, ISBN: 90- 386- 1556- 6
- Schmidt, K.H., 1982: *Beheizung von Kirchen*, DBZ Bauerneuerung 9/82, p.1227-1230
- Schoffelen, M.E.A., Limpens-Neilen, D., 2005: *Comfort Experiments in a Climate Room – “Friendly Heating”*, internal report FAGO 05.18.W Department of Architecture Building and Planning, capaciteitsgroep FAGO, TU/e, Eindhoven, The Netherlands
- Stangier, R., Rüegg, T., Stöckli, B., Lommel A., 1995: *Luftwechsel und Lüftungswärmeverlust der Evangelisch-Reformierten Kirche von Ebnat (SG)*. Untersuchungsbericht EMPA F+E 144
- Stolwijk, J.A.J., 1971: *A mathematical model of physiological temperature regulation in man*, NASA
- Thomson, G., 1978/1986: *The Museum Environment: Second Edition*, Butterworth-Heinemann Publisher Inc. Oxford, ISBN: 0- 7506 -2041- 28, 308p.

- Wit, M.H. de, 2006: *Hambase: Heat, Air and Moisture Model for Building and Systems Evaluation*, TU/e, Eindhoven, The Netherlands, ISBN: 90- 6814- 601- 7
- Wyon, D.P., Larsson, S., Forsgren, B., Lundgren, I., 1989: *Standard procedures for assessing vehicle climate with a thermal manikin*. SAE Technical Paper Series 890049, p. 1–11
- Young, A.J., Lee, D.T., 1997: *Ageing and human cold tolerance*, Experimental Ageing Research, 23, p.45-67
- Zanten, M. van, 1995: *Gids voor Behoud en Beheer van Kerkelijk Kunstbezit: een praktische handleiding.*, Stichting Kerkelijk Kunstbezit in Nederland., CRM-reeks deel 2, Sdu Uitgeverij Koninginnegracht Den Haag, ISBN: 90- 12- 08061- 4

List of Publications

- Limpens-Neilen, D., Schoffelen, M.E.A., Rissanen, S., Schellen, H.L., 2006: *Thermal comfort of churchgoers in an experimental set-up of a cold church with a local heating system*. Conference paper on CD of the IEA2006 conference (International Ergonomics Association), Editors: R.N. Pikaar, E.A.P. Koningsveld, P.J.M. Settels, , Maastricht, The Netherlands
- Limpens-Neilen, D., Schoffelen, M.E.A., Schellen, H.L., 2005: *CFD Study on a Local Radiant Heating System and the resulting Indoor Climate*, Proceedings of the Building Simulation (BS2005) conference, Montreal, Canada, ISBN: 2- 553- 01152- 0
- Limpens-Neilen, D., Schoffelen, M.E.A., Schellen, H.L., 2005: *The influence of a local heating system on the indoor climate of a large room*, Proceedings 7th Symposium on Building Physics in the Nordic Countries, Reykjavik Iceland, ISBN: 9979- 9174- 5- 8
- Limpens-Neilen, D., Schellen, H.L., 2005: *De invloed van een lokaal verwarmingssysteem op het binnenklimaat van een kerk*, Bouwfysicablad, NVBV, special Bouwfysica van Monumenten, 2005- 4, ISSN: 0928- 5377 (in Dutch)
- Limpens-Neilen, D., Schoffelen, M.E.A., Schellen, H.L., 2004: *Design study of a local bench heating system for churches, performed by computer simulation*, Proceedings of the 21st International Conference PLEA2004, Eindhoven, The Netherlands, ISBN: 90- 386- 1636- 8, p.799-803
- Schellen, H.L., Limpens-Neilen, D., Schoffelen, M.E.A., 2004: *Tools to evaluate and/or design heating systems in monumental churches*, Proceedings of the conference PLEA 2004, Eindhoven, ISBN: 90- 386- 1636- 8
- Schoffelen, M.E.A., Limpens-Neilen, D., Schellen, H.L., 2004: *Measurement Set-up for the Verification of CFD Modelling Used in a Design Study for a Local Bench Heating System for Churches*, Proceedings of the 21st International Conference PLEA2004, Eindhoven, ISBN: 90- 386- 1636- 8, p. 821-826

- Limpens-Neilen, D., Schoffelen, M.E.A., Schellen, H.L., 2004: *Thermal performance of a local bench heating system for churches*, Proceedings (CD-ROM) of the ROOMVENT 2004 conference, Coimbra, Portugal, ISBN 972- 97973- 2- 3
- Limpens-Neilen, D., Schoffelen, M.E.A., Schellen, H.L., 2004: *Measurements and simulation results of a local bench heating system*, IAQ2004 conference on Indoor Air Quality in Museums and Archives, Padova
- Schoffelen, M.E.A., Limpens-Neilen, D., Schellen, H.L., 2004: *Onderzoek naar lokaal thermisch klimaat bij gebruik van kerkbankverwarming*, Bouwfysica, vol. 17, 2004- 2 , pp. 14-21, (in Dutch)
- Spolnik Z., Worobiec A., Injuk J., Neilen D., Schellen H.L., van Grieken R., 2004: *Chemical Characterization of Airborne Particles in St. Martinus Cathedral in Weert (The Netherlands)*, Microchemica Acta, 145, p.223-227
- Neilen, D., Schellen, H.L., Aarle, M.A.P.van, 2003: *Characterizing and comparing monumental churches and their heating performance*, Proceedings of the International Building Physics Conference te Leuven, Research in Building Physics, ISBN: 90- 5809- 565- 7
- Schellen, H.L., Schijndel, A.W.M. van, Neilen, D., 2003: *Damage to a monumental organ due to wood deformation caused by church heating*, Proceedings of the International Building Physics Conference te Leuven, Research in Building Physics, p.803-811, ISBN: 90- 5809- 565- 7
- Neilen, D., Schellen, H.L., 2003: *Report of the 1st annual meeting of the EU-project "Friendly Heating"*, FAGO Internal report, TU/e, Eindhoven, The Netherlands

Nomenclature

a	height	[m]
Ar	Archimedes number	[-]
b	width	[m]
c_p	constant pressure specific heat	[J/kgK]
$C_{\mu}, C_{1\epsilon}, C_{2\epsilon}, C_{3\epsilon}$	coefficients in turbulence model	[-]
D_h	hydraulic diameter	[m]
DR	draught risk	[%]
EHT	equivalent homogeneous temperature	[°C]
G_b	generation of k due to buoyancy	[W/m ³]
G_k	generation of k due to the mean velocity gradients	[W/m ³]
g	gravitational acceleration	[m/s ²]
h	height	[m]
I_{clo}	thermal resistance from skin to outer surface of the clothed body (1 clo = 0.155 m ² K/W)	[clo]
I_{clr}	resultant thermal resistance of the clothing	[clo]
$IREQ_{min}$	required minimal I_{clo} , to avoid a thermal sensation vote lower than “slightly cool” (TSV= -1)	[clo]
$IREQ_{neut}$	required I_{clo} , for maintaining the heat balance of the human body (TSV=0)	[clo]
l	length	[m]
k	turbulent kinetic energy per unit mass	[J/kg]
L	characteristic length	[m]
M	rate of metabolic heat production	[W/m ²]
N	quantity	[-]
n	air exchange rate	[h ⁻¹]
p	statistic significance level	[-]
p	vapour pressure	[Pa]
PMV	predicted mean vote	[-]
PPD	predicted percentage of dissatisfied	[%]

Pr_t	turbulent Prandtl number for energy	[-]
r	(Pearson) correlation coefficient	[-]
R	additional source term introduced in RNG k-e model	[W/m ³ s]
Re	Reynolds number	[-]
RH	relative humidity	[%]
S_{ij}	magnitude of rate-of-strain	[s ⁻¹]
T	temperature	[K]
TI	turbulence intensity	[%]
TSV	thermal sensation vote	[-]
u	air velocity	[m/s]
u_i, u_j	index notation of velocity components	[m/s]
u_0	supply air velocity at the inlet	[m/s]
w	width	[m]
W	rate of mechanical work	[W/m ²]
x_i, x_j	index notation of Cartesian coordinates	[m]

Greek symbols

β	volumetric thermal expansion coefficient	[K ⁻¹]
Γ	diffusion coefficient	[kg/ms]
Δ	difference	
ε	emission factor	[-]
ε	rate of dissipation of turbulent kinetic energy per unit mass	[m ² /s ³]
η_0, η_s	parameters in RNG- <i>k</i> - <i>e</i> model	[-]
η_p^2	partial eta squared	[-]
θ	temperature	[°C]
Λ	Wilks lambda	[-]
μ	dynamic viscosity	[kg/ms]
ρ	density	[kg/m ³]
σ	standard deviation	
$\sigma_{k,\varepsilon}$	turbulent Prandtl (<i>k</i> , ε) number	[-]
φ	relative humidity	[-]

Subscripts

a	air
a,supply	supply air
eff	effective
h	hydraulic
i	indoor air
m	mean
n	body part n
r	radiant
s	surface
sk	skin
t	turbulent
0	at inlet
0	initial

Abbreviations

'none'	no local heating element operating
'sb'	seat and back element operating
'sbk'	seat, back and knee element operating
'sk'	seat and knee element operating
meas	measurements
RNGke	RNG k- ϵ model
real ke	realizable k- ϵ model
ske	Standard k- ϵ model
TN	Department of Applied Physics (Technische Natuurkunde)
TUD	Delft University of Technology (TU Delft)
TU/e	Eindhoven University of Technology (TU Eindhoven)
WP	Work Package
WTB	Department of Mechanical Engineering (Werktuigbouwkunde)

List of Tables

Table 2.1: Criteria for the conservation of monumental churches and interior...	19
Table 2.2: Energy consumption in the church for one service.....	21
Table 2.3: Specifications of the heating elements.....	23
Table 3.1: Specifications of the heating elements tested in the climate room.....	32
Table 3.2: Overview measurements and their purpose	34
Table 3.3: Overview of quantitative measurement results.....	39
Table 4.1: Comfort criteria of volunteers' skin temperatures	48
Table 4.2: Number of volunteers per heating system configuration.....	49
Table 4.3: Mean skin temperature increase [°C] of the various body parts	54
Table 4.4: Averaged maximum skin temperature gradient over the body.....	54
Table 4.5: Statistical results of the one-way Repeated Measures ANOVA.....	60
Table 4.6: Necessary parameters to calculate predicted mean vote (PMV)	64
Table 4.7: Calculated PMV, PPD and IREQ indices	64
Table 4.8: Criteria for preventing local discomfort.....	65
Table 5.1: Overview of variants investigated in CFD and climate room.....	88
Table 5.2: Local climate in the bench area at an height of 0.215m	90
Table 5.3: Heating capacity & energy consumption during a week in winter...	101

List of Figures

Figure 2.1: Overview work packages (partners) of the European project.....	11
Figure 2.2: Measuring the dimensional changes of the wooden altar objects.....	14
Figure 2.3: Photograph of church of Rocca Pietore and its interior.....	16
Figure 2.4: Air inlet and return grill of the air heating system.....	17
Figure 2.5: θ_a and RH measured when operating the air heating system.....	18
Figure 2.6: Simulated temperature stratification due to air heating system.....	21
Figure 2.7: Position of heating elements in the bench, church of Rocca Pietore.	22
Figure 2.8: θ_a and RH measured when operating the local heating system.....	25
Figure 2.9: θ_a and RH and dimensional changes in the wooden altar object	25
Figure 2.10: Thermal sensation and thermal comfort rating in the church.....	26

Figure 3.1: Configuration of the climate room with benches.....	30
Figure 3.2: Position of heating elements in the bench, climate room set-up.....	31
Figure 3.3: Surface temperature of the heating elements as a function of time... 33	
Figure 3.4: Verification of the heat production of the manikin.....	35
Figure 3.5: Measuring grid, position of measurement plane and manikin.....	38
Figure 3.6: IR thermography and smoke test, seat heating element.....	40
Figure 3.7: IR thermography and smoke test, back heating element.....	41
Figure 3.8: IR thermography and smoke test, kneeler pad heating	41
Figure 3.9: Temperature increase on the manikin, seat heating element.....	43
Figure 3.10: Temperature increase on the manikin, back heating element.....	43
Figure 3.11: Temperature increase on the manikin, kneeler pad element.....	43
Figure 4.1: Photograph of volunteers in the climate room set-up	50
Figure 4.2: Average mean skin temperatures, different heating configurations..	51
Figure 4.3: Measured skin temperatures of the volunteers per heating system... 52	
Figure 4.4: Thermal Sensation votes for different heating configurations	55
Figure 4.5: Thermal Sensation votes in relation to calculated PMV index.....	56
Figure 4.6: Thermal Comfort votes for different heating configurations.....	57
Figure 4.7: Thermal Preference votes for different heating configurations.....	58
Figure 4.8: Perception of air movements for different heating configurations. ...	58
Figure 4.9: Positions of temperature and velocity sensors.....	61
Figure 4.10: Representation of human being in thermophysiological model.....	71
Figure 4.11: Mean skin temperature, simulation versus measurement.....	73
Figure 4.12: Mean skin temperature, simulation vs measurement, pre-cooling .	73
Figure 5.1: Multi grid approach of the simulation models.....	79
Figure 5.2: Grid distribution of the multi grid model.....	80
Figure 5.3: Verification of temperature distribution: CFD versus Infra-Red.....	85
Figure 5.4: Verification of air flows: CFD versus smoke tests.....	85
Figure 5.5: Verification of different turbulence models.....	87
Figure 5.6: Photographs of bench lay-out in variant study.....	88
Figure 5.7: Air flows entering the bench area from the side: variant 2 & 3.....	89
Figure 5.8: CFD geometry of one person placed on the bench.....	90
Figure 5.9: Increase in skin temperature: variants compared to standard case... 91	
Figure 5.10: Simulated θ_a and air velocity in the church, air heating system	93
Figure 5.11: CFD model of the church of Rocca Pietore.....	94

Figure 5.12: CFD results: church & 12 benches with local heating system..... 95
Figure 5.13: CFD results: u_a , cross section through bench area in the church..... 96
Figure 5.14: Overview of the building simulation tool Hambase..... 97
Figure 5.15: Simulated versus measured indoor climate, air heating system..... 98
Figure 5.16: Calculated θ_a and RH near walls and windows, air heating..... 98
Figure 5.17. Simulated versus measured indoor climate, local heating system. 100
Figure 5.18. Calculated θ_a and RH near walls and windows, local heating..... 100

Appendix A

A.1 Archimedes number

The Archimedes number can be described as the ratio of buoyancy (natural air movement due to temperature difference) and the kinetic energy (forced air movement due to the impulse with which the air is blown into the room). The number can be calculated using the equation

$$Ar = \frac{g \cdot \Delta T_0 \cdot D_h}{T_i \cdot u_0^2}, \quad (\text{A-1})$$

where,

Ar	= Archimedes number	[-]
g	= gravitational acceleration	[m/s ²]
ΔT_0	= temperature difference between inlet-air and indoor air	[K]
D_h	= hydraulic diameter	[m]
T_i	= indoor air temperature	[K]
u_0	= air supply velocity at the inlet	[m/s]

and D_h is calculated according to the formula for calculating the hydraulic diameter for a rectangular wall air inlet supply:

$$D_h = 1.27 \cdot \sqrt[5]{\frac{(a \cdot b)^3}{(a + b)}}, \quad (\text{A-2})$$

where,

a	= height of the inlet	[m]
b	= width of the inlet	[m]

Appendix B Thermal comfort

B.1 Necessary parameters to calculate predicted mean vote (PMV) and their recommended interval

Parameter (symbol)	Unit	Recommended interval
Rate of mechanical work (W)	W/m ²	-
Metabolic rate (M)	W/m ²	46 to 232
Thermal insulation clothing (I_{cl})	clo	0 to 2
Air temperature (θ_a)	°C	10 to 30
Mean radiant temperature (θ_r)	°C	10 to 40
Vapour pressure (p_a)	Pa	0 to 2700
Air velocity (u_a)	m/s	0 to 1

B.2 Calculation of the PMV value per volunteer

Session 1						
Radiant temperature [°C]	Air temperature [°C]	Relative Humidity [%]	Air velocity [m/s]	Person	I_{cl} [clo]	PMV [-]
20.2	14.5	65	0.4	2	1.53	-0.41
				3	1.47	-0.49
				4	1.50	-0.45
Session 2						
Radiant temperature [°C]	Air temperature [°C]	Relative Humidity [%]	Air velocity [m/s]	Person	I_{cl} [clo]	PMV [-]
20.3	13.9	70	0.4	8	1.44	-0.59
				9	1.01	-1.39
				10	0.84	-1.84
Session 3						
Radiant temperature [°C]	Air temperature [°C]	Relative Humidity [%]	Air velocity [m/s]	Person	I_{cl} [clo]	PMV [-]
20.1	13.5	78	0.4	1	1.13	-1.16
				5	1.07	-1.29
				6	1.22	-0.98
				7	1.46	-0.59
				11	1.22	-0.98

Session 4						
Radiant temperature [°C]	Air temperature [°C]	Relative Humidity [%]	Air velocity [m/s]	Person	I _{cl} [clo]	PMV [-]
20.3	13.8	77	0.5	12	1.41	-0.70
				13	1.16	-1.15
				14	0.92	-1.73
				15	1.47	-0.61
				16	1.46	-0.62
Session 5						
Radiant temperature [°C]	Air temperature [°C]	Relative Humidity [%]	Air velocity [m/s]	Person	I _{cl} [clo]	PMV [-]
8.3	9.1	97	0.1	17	1.46	-1.31
				18	1.13	-1.91
				19	1.32	-1.54
				20	1.20	-1.76
Session 6						
Radiant temperature [°C]	Air temperature [°C]	Relative Humidity [%]	Air velocity [m/s]	Person	I _{cl} [clo]	PMV [-]
10.9	10.5	85	0.1	21	1.25	-1.36
				22	1.27	-1.33
				23	1.10	-1.65
				24	1.44	-1.06
				25	1.47	-1.02
Session 7						
Radiant temperature [°C]	Air temperature [°C]	Relative Humidity [%]	Air velocity [m/s]	Person	I _{cl} [clo]	PMV [-]
10.8	10.4	86	0.1	26	1.49	-1.00
				27	1.13	-1.60
				28	1.15	-1.56
				29	1.13	-1.60
				30	1.27	-1.34
Session 8						
Radiant temperature [°C]	Air temperature [°C]	Relative Humidity [%]	Air velocity [m/s]	Person	I _{cl} [clo]	PMV [-]
20.3	13.3	77	0.5	31	1.35	-0.86
				32	0.98	-1.64
				33	1.35	-0.86
				34	1.39	-0.79
				35	1.03	-1.52
Session 9						
Radiant temperature [°C]	Air temperature [°C]	Relative Humidity [%]	Air velocity [m/s]	Person	I _{cl} [clo]	PMV [-]
8.5	8.5	76	0.1	36	1.20	-1.85
				37	1.33	-1.61
				38	1.20	-1.85
				39	1.25	-1.76
Session 10						
Radiant temperature [°C]	Air temperature [°C]	Relative Humidity [%]	Air velocity [m/s]	Person	I _{cl} [clo]	PMV [-]
11.2	10.6	84	0.1	40	1.48	-0.98
				41	1.06	-1.70
				42	1.39	-1.11
				43	1.22	-1.3

B.3 Questionnaires comfort study volunteers

Personal details of the volunteer, specified by himself / herself

FRIENDLY HEATING	September 2003
Date _____	
Name _____	Gender: M / F
Age _____	
Length _____	
Weight _____	
Do you use medication? If yes, please specify what for: _____	
Clothing _____	

1. Thermal sensation ("How are you feeling now?")

		Time (minutes since entering the climate room)					
	Pre	0	15	25	45	55	70
General							
Head							
Upper body							
Bottom							
Arms							
Hands							
Fingers							
Legs							
Toes							

2. Thermal comfort ("Do you find this...?")

	Pre	0	15	25	45	55	70
General							
Head							
Hands							
Fingers							
Legs							
Toes							

3. Perception of air movements

	Pre	0	15	25	45	55	70
General							
Head							
Left side of the body							
Right side of the body							

4. Thermal preference scale

	Pre	0	15	25	45	55	70
much warmer							
warmer							
slightly warmer							
neither warmer nor cooler							
slightly cooler							
cooler							
much cooler							

Judgement scales

1. Thermal sensation ("How are you feeling now?")

- 3 hot
- 2 warm
- 1 slightly warm
- 0 neutral
- 1 slightly cool
- 2 cool
- 3 cold
- 4 very cold

2. Thermal comfort ("Do you find this...?")

- 0 comfortable
- 1 slightly uncomfortable
- 2 uncomfortable
- 3 very uncomfortable
- 4 extremely uncomfortable

3. Perception of air movements. The testperson.....

- | | | |
|---|---|-----------------|
| 0 | doesn't feel the presence of any air movement | (not at all) |
| 1 | feels a weak air movement, but not constantly | (very slightly) |
| 2 | continuously feels a weak air movement | (slightly) |
| 3 | continuously feel an air movement with moderate intensity | (definitely) |
| 4 | continuously feels an intense air movement | (a lot) |

B.4 Measured skin temperatures per heating configuration

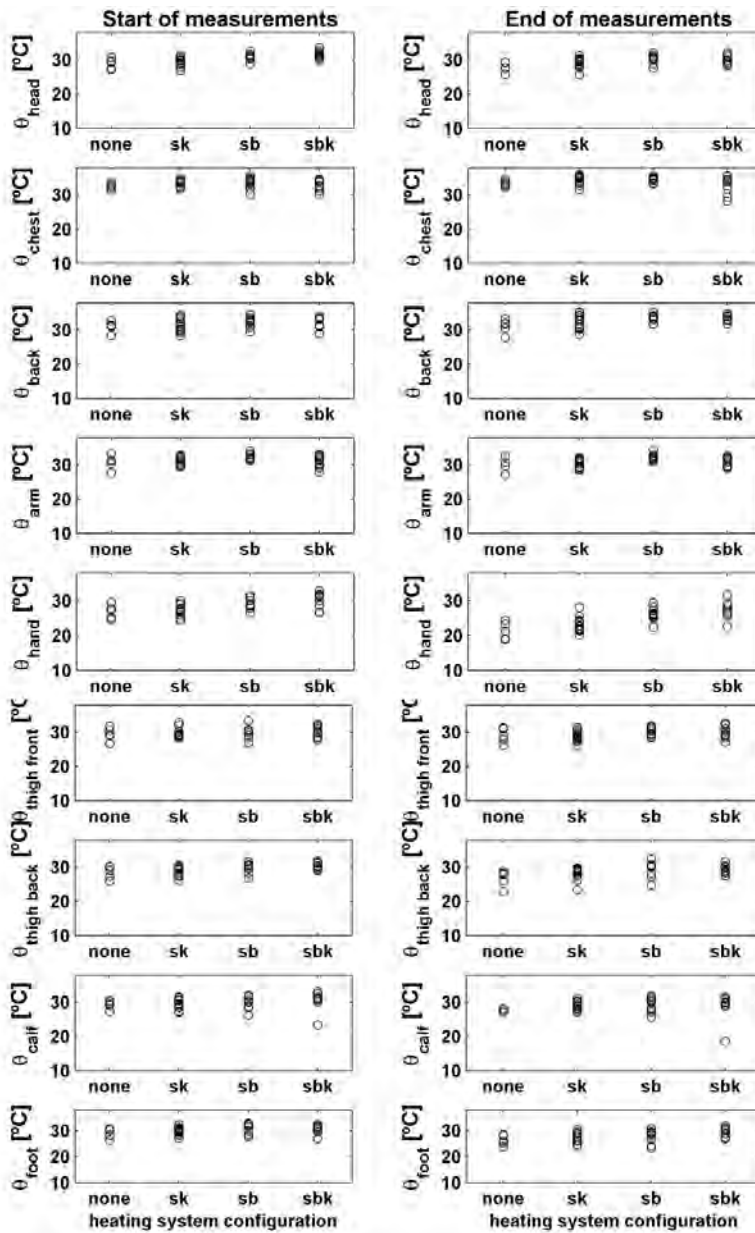

Dankwoord

Na het vieren van mijn 10-jarig jubileum aan de TU/e op 1 september 2006, is de tijd aangebroken om de TU/e omgeving te verlaten en elders aan de slag te gaan. Ik heb de afgelopen jaren hier met veel plezier doorgebracht en zal er nog vaak aan terugdenken. Eerst wil ik echter alle mensen die op enige wijze hebben bijgedragen aan de afronding van mijn promotieonderzoek, van harte bedanken.

Allereerst mijn promotor Martin de Wit, en co-promotor Henk Schellen. Bedankt voor alle hulp, begeleiding, discussies, maar ook de gezellige praatjes tijdens de 4 jaar van mijn promotietraject. Ook Ton Jütte wil ik hartelijk danken voor zijn kritische opmerkingen en vragen die hij gegeven cq gesteld heeft als lid van mijn kerncommissie. Ton kende de inhoud van het EU-project, en toch wist hij een dusdanige afstand te nemen tijdens het doorlezen van mijn teksten, dat hij er veel dingen uitviste die voor mij inmiddels vanzelfsprekend zijn, maar meer uitleg behoeven voor mensen die het EU-project niet kennen. Ook de overige leden van mijn kerncommissie wil ik bedanken: Rob van Hees (TUD) en Gert-Jan van Heijst (TU/e TN) voor het doorlezen van mijn hoofdstukken en het leveren van kritische op- en aanmerkingen. Ik ben erg blij dat alle leden van mijn kerncommissie zo enthousiast waren.

My research started as a part of the European project “Friendly Heating”. I would like to thank all the colleagues of the European project for their cooperation, and the wonderful days we have spent in the Italian Dolomites.

Thanks to Sandra Mancini who checked the English language of my thesis.

Mijn dank gaat ook uit naar de mensen die het mogelijk gemaakt hebben om de opstelling in de klimaatkamer te realiseren: Guus Theuws en Stan van Asten die de kerkbanken uit Italië nagebouwd hebben, altijd meedachten over de uitvoering van de meetopstelling en waar je altijd kon rekenen op een bakje koffie en veel gezelligheid. Erwin Smits wil ik bedanken voor de EHBKK (Eerste Hulp Bij Klimaatkamer Kuren) en Peter Swinkels (Aqua2000) voor het geven van een cursus koeltechniek telkens wanneer hij de koelmachines weer moest reanimeren. Wout van Bommel, Marcel van Aarle en Peter Cappon wil ik bedanken voor het regelen, meedenken en kalibreren van de meetapparatuur, en Harrie Smulders en

Jan Diepens voor het verzorgen van de UNIX faciliteiten die nodig waren voor mijn CFD simulaties.

Dan zijn er nog diverse studenten die ik heb begeleidt tijdens hun afstuderen/of masterproject. Ook hen wil ik hartelijk bedanken voor hun bijdrage: Mariëlle Schoffelen voor het ontwikkelen van de opstelling in de klimaatkamer, Christa de Vaan en Karin Grooten voor het onderzoeken van de invloed van straling op de sensoren, en Jessica Verdonschot en Linda Chabot voor het onderzoeken van mogelijke tochtklachten in de banken.

Verder wil ik alle proefpersonen bedanken voor hun deelname aan de comfortstudie in de klimaatkamer.

Ik ben ook zeer dankbaar voor de samenwerking met Arjan Frijns (TU/e WTB), die er voor gezorgd heeft dat hun thermofysiologisch model aangepast werd, zodat het in onze klimaatkameropstelling toegepast kon worden.

Alle collega's van de capaciteitsgroep FAGO (de tegenwoordige unit BPS) wil ik hartelijk bedanken voor hun interesse en de fijne sfeer binnen de groep.

I would like to thank all colleague-PhD's for their participation in the weekly AIO-coffee, for playing volleyball on Fridays, and for the nice chats near the coffee machine. A special thanks to Ery Djunaedy, for adding culture to our conference trips: "Why is that statue standing here?"

Enkele collega's wil ik extra bedanken. Zij hebben de afgelopen jaren een speciaal, warm plekje in mijn hart veroverd: Myriam Ariës, Toine Schoutens en Mariëlle Schoffelen. Bedankt voor de nodige humor, het op peil houden van het cafeïnegehalte, en de uitermate gezellige uitstapjes die we met 'studievereniging' DiMyToMa gemaakt hebben. De ideale ontspanning tussendoor en perfect om van het grote aantal verlofdagen af te komen.

Myriam, begonnen als collega-AIO en vervolgens via sportmaatje (volleyballen, zwemmen, douchen op topsportniveau) uitgegroeid tot mijn beste vriendin. Als "draakje" de perfecte aanvulling op het "spookje" en (zelfs met een oceaan en 6 uur tijdsverschil ertussen) een grote steun in mijn laatste promotiejaar. Bedankt!

Toine, begonnen als "Mystery Man in onze kantoortuin", vervolgens ieder jaar een bureau dichterbij komen zitten, en uiteindelijk (wederom) vrijwel onmisbaar gebleken in het laatste jaar van een promovenda. Bedankt voor het luisterend oor en alle steun, motivatie en ontspanning tijdens en buiten werktijden.

Mariëlle Schoffelen wil ik bedanken voor alle werk dat ze verricht heeft als afstudeester (ontwikkelen meetopstelling en het verwijderen van meetdata) en tijdens het extra jaar waarin ze als toegevoegd onderzoeker meegewerkt heeft aan mijn promotieonderzoek (thermisch comfort). Bedankt voor alle meligheid tijdens de koude uren in de klimaatkamer (zelfs toen we opgesloten zaten), en de zeer warme momenten wanneer we in onze fleecetrui vanuit de kou naar buiten liepen waar het 30°C was.

Verder wil ik mijn familie, vrienden en kennissen bedanken voor alle interesse, steun en broodnodige ontspanning. Met name ook mijn ouders, schoonouders, zus, schoonbroers en mijn neefje Delano.

Last but not least wil ik Erwin bedanken. Zonder zijn programmeerkunst had ik mijn simulaties niet zo snel uitgewerkt gekregen. Bovendien heeft hij veel werk verzet door mijn teksten steeds maar weer door te lezen en te controleren. Hij heeft mijn gehele decennium op de TU/e meegemaakt en mij de kans gegeven om te gaan promoveren. Bedankt hiervoor en voor alle steun die ik de afgelopen jaren van je heb mogen ontvangen.

Dionne
augustus 2006



(Ru de Vries,
Limburgs Dagblad
dd. okt 2003)

Curriculum vitae



- July 12th 1977 Born in Sittard (The Netherlands)
- 1989-1996 Education at pre-university level (VWO-Atheneum diploma) at Bisschoppelijk College in Sittard
- 1996-2002 Master of Science in Architecture in the specialization Building Physics at the department of Architecture, Building and Planning at the Eindhoven University of Technology
Graduation project entitled ‘Monumentale Kerken met Verwarming – Karakterisering aan de hand van Bouwfysische Kengetallen’ (Heating Monumental Churches: Characterisation with the help of Building Physical Parameters) under supervision of prof. M.H. de Wit, Ph.D., H.L. Schellen, M.Sc., B.A.H.G. Jütte, Ph.D., and A.W.M. van Schijndel, M.Sc.
- 2002-2006 Ph.D. research at Eindhoven University of Technology, Department of Architecture, Building and Planning, unit Building Physics and Systems under supervision of prof. M.H. de Wit, Ph.D., and H.L. Schellen, Ph.D.

