

Recovery of work from exothermic chemical reaction systems by means of turbine expansion

Citation for published version (APA):

Greeff, I. L. (2004). *Recovery of work from exothermic chemical reaction systems by means of turbine expansion*. [Phd Thesis 2 (Research NOT TU/e / Graduation TU/e), Chemical Engineering and Chemistry]. Technische Universiteit Eindhoven. <https://doi.org/10.6100/IR571454>

DOI:

[10.6100/IR571454](https://doi.org/10.6100/IR571454)

Document status and date:

Published: 01/01/2004

Document Version:

Publisher's PDF, also known as Version of Record (includes final page, issue and volume numbers)

Please check the document version of this publication:

- A submitted manuscript is the version of the article upon submission and before peer-review. There can be important differences between the submitted version and the official published version of record. People interested in the research are advised to contact the author for the final version of the publication, or visit the DOI to the publisher's website.
- The final author version and the galley proof are versions of the publication after peer review.
- The final published version features the final layout of the paper including the volume, issue and page numbers.

[Link to publication](#)

General rights

Copyright and moral rights for the publications made accessible in the public portal are retained by the authors and/or other copyright owners and it is a condition of accessing publications that users recognise and abide by the legal requirements associated with these rights.

- Users may download and print one copy of any publication from the public portal for the purpose of private study or research.
- You may not further distribute the material or use it for any profit-making activity or commercial gain
- You may freely distribute the URL identifying the publication in the public portal.

If the publication is distributed under the terms of Article 25fa of the Dutch Copyright Act, indicated by the "Taverne" license above, please follow below link for the End User Agreement:

www.tue.nl/taverne

Take down policy

If you believe that this document breaches copyright please contact us at:

openaccess@tue.nl

providing details and we will investigate your claim.

Recovery of work from exothermic chemical reaction systems by means of turbine expansion

PROEFSCHRIFT

ter verkrijging van de graad van doctor aan de
Technische Universiteit Eindhoven, op gezag van de
Rector Magnificus, prof.dr. R.A. van Santen, voor een
commissie aangewezen door het College voor
Promoties in het openbaar te verdedigen op
donderdag 26 februari 2004 om 16.00 uur

door

Isabella Lodewina Greeff

geboren te Vereeniging, Zuid-Afrika

Dit proefschrift is goedgekeurd door de promotoren:

prof.dr.ir. F.J.J.G. Janssen
en
prof.dr. J.A. Visser

Copromotor:
dr.ir. K.J. Ptasinski

CIP-DATA LIBRARY TECHNISCHE UNIVERSITEIT EINDHOVEN

Greeff, Isabella L.

Recovery of work from exothermic chemical reaction systems by means of turbine expansion / by Isabella L. Greeff. – Eindhoven: Technische Universiteit Eindhoven, 2004.
Proefschrift. – ISBN 90-386-2785-8

NUR 913

Trefwoorden: thermische energietechniek / chemische technologie / turbines / energieproductie / warmteterugwinning; reactie-enthalpie / fysisch-chemische simulatie en modellering / exotherme reacties; expansie

Subject headings: thermal energy technology / chemical process design / turbines / power generation / heat recovery; reaction enthalpy / physicochemical simulation and modelling / exothermic reactions; expansion

Preface

The publication of this thesis is a major milestone in my life. It marks the end of a very interesting and busy time during which I changed employers twice, moved house and was blessed by a baby son. I am grateful for having been given the opportunity to do this doctorate at the University of Eindhoven while based in South Africa.

First, I wish to thank my family for their support through all of this. My husband in particular spent a lot of his time to keep our son, Jacobus, busy while I worked on this thesis. Without him it would have been impossible to achieve this.

Secondly, I wish to thank my Dutch supervisors, Frans Janssen and Krzysztof Ptasinski, as well as my supervisor in South Africa, Jan Visser, for their support and contribution to the work. A doctoral thesis is indeed not an individual effort.

Many thanks to Denise Tjallema-Dekker for guiding me through the administrative procedures and also for helping with travel arrangements for my study visits to Eindhoven.

My appreciation is also due to Jaco Perold for his contribution to some of the case studies in this thesis. It was a great pleasure to have Jaco as a masters student.

Lastly, I wish to thank Patrick van Schijndel for his friendship and especially for him and his family who hosted me on several occasions during my visits to Eindhoven.

Summary

The purpose of this work is to study the integration of turbine expanders with exothermic, high-pressure gas-phase chemical reactor systems for direct conversion of the reaction heat into electrical energy. This thesis describes a unique approach to combining turbine expanders with chemical reactors.

The reaction heat of exothermic reactions is usually transferred by heat exchange to another fluid for use at a different location. By doing this, the heat is downgraded in quality. Steam raising systems are commonly implemented. The steam may be exported, used for process heating or to generate power in steam turbines, either for export or process requirements. Heat is however more valuable or of a higher quality, the further its temperature is from the ambient. From a Second Law viewpoint, it is therefore more efficient to recover reaction heat by direct expansion of the hot, high-pressure product gas in a turbine expander. In such integrated systems the process gas is used as a working fluid in a power cycle while a chemical is also produced. More efficient conversion of the reaction heat to electricity may also translate into a benefit to the environment, due to decreased emissions of CO₂, NO_x and SO_x associated with power generation from fossil fuels.

Turbine expanders are high efficiency turbines that exclude steam and combustion gas turbines. Most of the hydrocarbon gas expanders are designed for power recovery and can be directly connected to a process compressor on the same shaft. Literature indicates that turbine expander technology is well developed and can be customised to meet the requirements of different operating scenarios. Temperatures up to 870 °C can be accommodated, and equipment sizes range from 75 kW to 10 MW and even up to 130 MW. Designs are available for coping with condensing gas streams and streams containing suspended solid particles.

Examples of integration of turbine expanders with chemical process streams are scarce and are mostly found in patent literature. The literature review revealed that turbine expanders are usually placed in flue gas, reactor tail gas or feed gas where it does not impact on the process operations. Placement of these machines downstream of reactors impacts the process design, especially in the case of a reaction system with recycle of the non-converted reactants.

A number of patents on the combination of gas turbines with chemical plants or integration of turbine expanders directly with process streams has been issued. Up to date only three patents could be found that deal with a turbine expander placed directly behind an exothermic reactor. The concept of expanding hot reactor product gas is therefore new and an investigation is needed to generalise the concept and find further applications.

It is also clear that there is a need for a design approach or methodology to develop flow sheet configurations for chemical reaction systems combined with turbine expanders. This work

addresses this need by developing such a methodology. Parameters that impact on the integrated systems are also identified and their roles investigated. Lastly, criteria of performance and various practical aspects are investigated.

Method

The purpose of this research is achieved by conducting a number of conceptual case studies on different chemical reaction processes. These processes all comprise exothermic, high-pressure reactions, but otherwise differ significantly in terms of aspects such as reactor operation, separation techniques, reactant conversion etc. The chemicals are also produced on a global scale using well-known processes. Realistic modelling of the processes is therefore possible. Process data are generated using simulations. The level of modelling and simulation is of a conceptual nature to investigate and illustrate fundamental principles, relations and trends.

The results of the case studies contribute to understanding the behaviour of typical process gas power cycles by illustrating how various parameters impact on the performance of the systems. In this regard useful mathematical models to describe two typical systems were also developed, namely an adiabatic reactor-separator system with equilibrium-limited reaction and one with reaction kinetics.

Results

The most important result of this work is a methodology that lends structure to the development and analysis of the flow sheets for chemical reaction systems that use turbine expanders to recover reaction heat. The application of this methodology was illustrated for various case studies. The methodology is based on a unique approach to combining a chemical reaction system with a power cycle. The approach firstly involves the realisation of the analogy between a chemical reaction system with expansion turbine and a conventional power generation cycle. Secondly, synergistic effects are identified and used to improve the flow sheet. Thirdly, appropriate system boundaries are defined to consider systems instead of single unit operations. Furthermore, in the design of flow sheets for these systems, a power cycle should be combined with the chemical process in such a way that the requirements of both the power cycle and the chemical process are satisfied. The methodology involves the consideration of various factors that were identified to impact on the flow sheet development. These factors include e.g. single pass or recycle operation, reaction conditions, reactor operation, conditions for separation of product and the physical properties of the process gas.

Case studies were done on the following processes: production of phthalic anhydride, ammonia, methanol, ethylene oxide and synthesis gas. All these studies show promising results concerning energy saving in the integrated processes versus the conventional processes.

In a case study on phthalic anhydride production two reaction-heat recovery schemes were compared. Both schemes also included a steam cycle for recovery of reaction heat. In one of the schemes an expansion turbine was included for process gas expansion. The turbine replaced an expansion valve in the conventional scheme. Results showed that, without the presence of the expansion turbine, there were certain operating conditions where the steam cycle alone could supply the total amount of required feed compression power. Inclusion of the expansion turbine made it possible to export power over and above the internal power requirement.

In a methanol case study a new methanol synthesis flow sheet that utilises the reaction heat more efficiently to drive the feed compressor was developed. In this flow sheet a steam cycle is combined with a process gas cycle, the reaction heat being divided between these cycles. High-pressure purge gas is also expanded to produce work. The conventional and improved processes were compared based on the work required per kg of methanol produced. Results show that the energy consumption of the conventional process with isothermal steam raising reactor is reduced by 43% if a steam turbine is used to provide some of the compressor work. In the flow sheet with integrated turbine expander the energy consumption is reduced by another 24%.

In a case study on ammonia production two alternative improved process flow sheets were developed via turbine expander integration. The ammonia synthesis process represents a typical reaction-separation system with recycle stream and cold separation of the product. The pressure ratio over the expander was found to play an important role in optimisation of an integrated system, specifically since the process comprises an equilibrium reaction. The pressure ratio influences the inlet temperature to the reactor. The change in reactor inlet temperature changes the conversion and therefore also the heat of reaction that is available to produce power. Sensitivity analyses were applied to determine the pressure ratios for the minimum work requirement per kg product as well as the minimum exergy loss per kg of product.

In terms of the minimum work requirement per kg of product the better of the two integrated ammonia flow sheets showed a 75% improvement over the conventional process. The work penalty due to refrigeration needed for separation was also included. This integrated flow sheet also resulted in a decrease in the exergy loss and the loss was more evenly distributed between the various unit operations.

An ethylene oxide (EO) synthesis flow sheet was also developed that makes use of process gas to produce power in combination with conventional steam power production. By increasing the reactor operating pressure, a turbine expander could be accommodated in the existing flow sheet. By integration of an expander it was possible to change the ethylene process from consuming 1 064 kJ/kg EO of energy to delivering 688 kJ/kg EO.

In a final case study a turbine expander was integrated into a synthesis gas production process based on autothermal reforming. The high temperature heat of the synthesis gas leaving the reformer is utilised more efficiently by expanding the gas to produce power in a combined cycle. This combined cycles comprises a process gas topping cycle and a steam bottoming cycle. The net work available from this integrated system increases with an increase in pressure ratio across the expander. At an expansion pressure of 5 bar it was shown that 41% more work is produced compared to the conventional system where only a steam cycle is utilised.

Since the case studies revealed the importance of pressure ratio across the turbine expander, simple mathematical models were used to illustrate the influence of the pressure ratio on various parameters in the process gas power cycles. Models were developed for two systems, namely an adiabatic reactor-separator system with equilibrium-limited reaction and one with reaction kinetics. In both models it was found that a high conversion in the reactor is not necessarily the best in terms of power production. The parameter that should be maximised is the work per mole flow of the recycle stream.

An important result of utilising reaction heat more efficiently to produce power is a reduction in the emission of carbon dioxide.

Conclusions and outlook

Flow sheets are important tools in the study of chemical reaction systems integrated with turbine expanders. Development of flow sheets for such systems are enhanced by realising the analogy to conventional power generation cycles. Processes equipped with turbine expanders utilise reaction heat more efficiently to produce power compared to conventional systems wherein the heat is transferred to a utility fluid. The concept of a process gas power cycle versus a utility fluid power cycle is best illustrated by using *heat engines*.

Various factors impact on the development of flow sheets for chemical reaction systems with integrated turbine expanders. These factors include single pass or recycle operation, reaction conditions, reactor operation, conditions for separation of product and the physical properties of the process gas. The methodology that was presented in this work considers these factors and provides a structured approach to the development of process gas power cycle flow sheets. In all case studies that were undertaken successful integration of a turbine expander was accomplished and exergy losses were reduced resulting in meaningful energy savings. The methodology was therefore proved to be successful thereby reaching the objective of this research.

Power savings or additional power production can be achieved by using turbine expansion for reaction heat recovery. Additional power may be used internally in a process or be exported.

Either way, emissions of carbon dioxide are avoided since less power is required from sources that contribute to these emissions. Even though there is controversy in certain parts of the world on the subject of greenhouse gases causing climate change, emissions trading of these gases is likely to become a reality. This will influence future process designs and economic evaluations of projects.

Implementation of the improved flow sheets that were developed in this work will obviously depend on the result of proper economic evaluations. In this regard there is a need to develop the conceptual flow sheets presented here further to a level of detail that will enable such evaluations. Simple economic calculations were however done. It was shown how the choice of manner in which any additional power is utilised, i.e. exported or used internally, influences the result of the economic evaluations.

Since the results of the all the case studies in this work were positive it is concluded that the idea of direct reaction heat recovery for power production has potential. It is hoped that the methods, guidelines and examples presented in this work will be useful for future conceptual designs of processes integrated with turbine expanders.

The concept of a process gas power cycle that uses a process gas as a working fluid should be developed further to promote the combination of chemical processes and power cycles on this integrated level. A structured approach to the design of chemical engineering systems is valuable and certainly improves the outcome.

Samevatting in Afrikaans

Die doel van hierdie navorsing is om die integrasie van ontspanningsturbines met eksotermiese, hoë-druk, gasfase chemiese reaktorsisteme te bestudeer. Ontspanning van die warm produk-gasse maak dit moontlik om die reaksiewarmte direk om te skakel na elektriese energie. Hierdie proefskrif beskryf 'n unieke benadering om ontspanningsturbines met chemiese reaktore te kombineer.

Die reaksiewarmte van eksotermiese reaksies word normaalweg deur hitte-ruiling oorgedra na 'n ander medium om elders in die proses gebruik te word. Hierdeur word die kwaliteit van die warmte verlaag. Sisteme vir die opwekking van stoom word algemeen gebruik. Die stoom kan uitgevoer word, gebruik word vir prosesverhitting of om krag op te wek in stoomturbines vir interne of eksterne gebruik. Warmte is meer waardevol of van 'n hoër kwaliteit met toename in die temperatuurverskil met die omgewing. Die Tweede Wet van termodinamika bepaal dat dit meer effektief is om reaksiewarmte te herwin deur direkte ontspanning van die warm, hoë-druk produk-gas in 'n ontspanningsturbine. In sulke geïntegreerde sisteme word die prosesgas gebruik as 'n werkvloeier in 'n krag-siklus terwyl 'n chemiese produk gelyktydig gelewer word. Meer effektiewe omsetting van reaksiewarmte na elektrisiteit het ook voordele vir die omgewing deur 'n afname in CO₂, NO_x en SO_x emissies wat met kragopwekking uit fossielbrandstowwe verbind word.

Ontspanningsturbines, met uitsluiting van stoom en ontbrandings-gasturbines, is masjiene met 'n besondere hoë effektiwiteit. Die meerderheid ontspanningsturbines vir koolwaterstofgasse is ontwerp vir kragherwinning en kan direk aan 'n kompressor op dieselfde as gekoppel word. Uit die literatuur is dit duidelik dat ontspanningsturbine tegnologie volwasse is en ook aangepas kan word om aan die spesifieke behoeftes van verskillende bedryftoestande te voldoen. Temperature tot en met 870 °C kan hanteer word en die toerusting-groottes wissel van 75 kW tot 10 MW en selfs so hoog soos 130 MW. Masjienontwerpe is beskikbaar om kondenserende gasstrome sowel as strome wat vastestofpartikels bevat te hanteer.

Voorbeelde van die integrasie van ontspanningsturbines met chemiese prosesstrome is seldsaam en word meesal in patentliteratuur beskryf. Die literatuuroorsig het getoon dat ontspanningsturbines hoofsaaklik in afgasstrome geplaas word waar die impak daarvan op die bestaande proseswerkinge nie noemenswaardig is nie. Deur die masjiene stroomaf van reaktore te plaas word die prosesontwerp wesenlik beïnvloed, veral in die geval van 'n reaksiesisteme met 'n hersirkuleerstroom.

Verskeie patente wat handel oor die kombinasie van gasturbines met chemiese aanlegte of direkte integrasie van ontspanningsturbines met prosesstrome is gepubliseer. Net drie patente is egter bekend waarin 'n ontspanningsturbine op die uitlaat van 'n eksotermiese reaktor

geplaas word. Die konsep om produkgas te ontspan is daarom nuut en 'n ondersoek is nodig om dit verder te ontwikkel en meer toepassings te vind.

Daar bestaan dus 'n behoefte aan 'n metodologie vir die skep van vloeiskemas vir chemiese reaksiesisteme waarin ontspanningsturbines gebruik kan word. Hierdie proefskrif beskryf die ontwikkeling van so 'n metodologie. Verder word parameters wat 'n impak het op die geïntegreerde sisteme geïdentifiseer en hulle rolle in die ontwerp bepaal. Ten slotte word kriteria vir werksverrigting asook verskeie praktiese aspekte ondersoek en beskryf.

Metode

Die ondersoek is uitgevoer deur middel van 'n aantal konseptuele gevallestudies oor verskillende chemiese prosesse. Alhoewel die prosesse almal eksotermiese reaksies wat by verhoogde druk plaasvind insluit, verskil die prosesse andersins heelwat in terme van eienskappe soos die reaktorbedryf, skeidingstegnieke, omsetting ens. Voorbeelde van bekende prosesse is gebruik om realistiese modellering te vergemaklik. Die vlak van modellering en simulering is egter konseptueel van aard om sodoende fundamentele beginsels, verwantskappe en neigings uit te lig.

Die resultate van die gevallestudies dra by tot 'n begrip vir die gedrag van 'n tipiese prosesgas krag siklus deur te illustreer hoe verskeie parameters 'n invloed uitoefen op die werkverrigting van die sisteme. In hierdie opsig is nuttige wiskundige modelle om twee tipiese sisteme te beskryf ook ontwikkel, naamlik 'n adiabatiese reaktor-skeidingsstelsel met 'n ewewigsreaksie en ook een wat reaksiekinetika insluit.

Resultate

Die belangrikste resultaat van die navorsing is 'n metodologie wat struktuur verleen aan die ontwikkeling en analise van vloeiskemas vir chemiese reaktorsisteme wat met ontspanningsturbines gekombineer word. Die toepassing van die metodologie is geïllustreer deur verskillende gevallestudies. Die metodologie is gebaseer op 'n unieke benadering tot die kombinasie van 'n chemiese reaksiesisteme met 'n krag siklus. Die eerste onderdeel van die benadering is die besef dat daar 'n analogie is tussen 'n chemiese reaksiesisteme met ontspanningsturbine en 'n konvensionele krag siklus. Tweedens word sinergieë geïdentifiseer en gebruik om die vloeiskema te verbeter. Derdens word geskikte sisteemgrense gekies om toe te laat dat sisteme in plaas van enkele eenheidswerkinge oorweeg word. Vervolgens behoort 'n krag siklus en chemiese proses op 'n manier gekombineer word wat toelaat dat daar aan die vereistes van beide die krag siklus en chemiese proses voldoen word. Die metodologie behels die oorweging van verskeie faktore wat geïdentifiseer is as faktore wat die vloeiskema ontwikkeling beïnvloed. Hierdie faktore sluit in: enkelstap of hersirkuleer bedryf van die reaksie, die reaksietoestand, die reaktor bedryf, die toestand vir skeiding van die produk en die fisiese eienskappe van die prosesgas. Die invloed van hierdie faktore word ondersoek.

Gevallestudies is gedoen op die volgende chemiese prosesse: produksie van ftaalsuuranhidried, ammoniak, metanol, etileenoksied en sintesegas. In al hierdie gevalle is belowende resultate betreffende energiebesparing in die geïntegreerde proses in vergelyking met die konvensionele proses verkry.

In die studie oor ftaalsuuranhidried word twee reaksiewarmte herwinningskemas vergelyk. Albei die skemas sluit ook 'n stoomsiklus in. 'n Ontspanningsturbine is in een van die skemas ingesluit op die reaktoruitlaat. Die turbine vervang 'n ontspanningsklep in die konvensionele proses. Resultate wys dat daar in die skema sonder die turbine sekere bedryfstoeistande bestaan waar die stoomsiklus genoeg werk kan voorsien om die voerkompressor aan te dryf. Met insluiting van die ontspanningsturbine is dit moontlik om ook krag uit te voer bo en behalwe die interne vereistes van die kompressor.

In die metanol gevallestudie is 'n metanol sintese vloeiskema ontwikkel wat reaksiewarmte meer effektief benut om die voerkompressor aan te dryf. In hierdie vloeiskema word die stoomsiklus gekombineer met die prosesgassiklus en die reaksiewarmte word verdeel tussen hierdie twee siklusse. Hoë-druk afblaasgas word ook ontspan om werk te produseer. Die konvensionele en geïntegreerde prosesse is vergelyk op die basis van die werk benodig per massa metanolproduksie. Resultate wys dat die energieverbruik vir die konvensionele proses met isothermiese stoomproduserende reaktor met 43% verminder word as 'n stoomsiklus gebruik word om 'n deel van die kompressorwerk te verskaf. In die vloeiskema met geïntegreerde ontspanningsturbine word die energieverbruik met 'n verdere 24% verminder.

In die ammoniak studie is twee alternatiewe vloeiskemas ontwikkel met die insluiting van 'n ontspanningsturbine. Hierdie proses verteenwoordig 'n tipiese reaksie-skeidings sisteem met hersirkuleerstream en koue skeiding van die produk. Daar is gevind dat die drukverhouding oor die turbine 'n belangrike rol speel in die optimering van die geïntegreerde sisteem, juis omdat die proses 'n ewewigsreaksie insluit. Die verandering in reaktorinlaattemperatuur verander die omsetting en daarom ook die reaksiewarmte wat beskikbaar gestel word vir gebruik deur die prosesgassiklus. Sensitiwiteitsanalises is gedoen om die drukverhouding vir die minimum werk per kg produk te bepaal asook vir die minimum eksergieverlies per kg produk.

Een van die twee ontwikkelde ammoniak vloeiskemas toon 'n 75% verbetering in energieverbruik in vergelyking met die konvensionele proses. Die verlies aan werk as gevolg van verkoeling vir koue skeiding is ook in ag geneem. In die geïntegreerde vloeiskema is die eksergieverlies ook minder en die verlies is meer eweredig verdeel tussen die verskillende eenheidswerkinge.

'n Etileenoksied (EO) vloeiskema is ook ontwikkel waarin 'n prosesgassiklus saam met 'n stoomsiklus geïmplementeer word. Die druk in die reaktor is verhoog om dit moontlik te

maak om 'n ontspanningsturbine in te sluit. Die proses is sodoende verander van 'n gebruiker van 1 064 kJ/kg EO werk na 'n proses wat 688 kJ/kg EO lewer.

'n Laaste gevallestudie is uitgevoer waarin 'n ontspanningsturbine met 'n sintesegasproses, gebaseer op outotermiese hervorming, geïntegreer is. Die hoë temperatuur warmte van die sintesegas wat die hervormer verlaat word meer effektief benut deur die gas te onspan in 'n gekombineerde siklus bestaande uit 'n hoë temperatuur prosesgassiklus (*topping cycle*) en lae temperatuur stoomsiklus (*bottoming cycle*). Die netto werk beskikbaar uit die geïntegreerde sisteem neem toe met 'n toename in drukverhouding oor die turbine. By 'n ontspanningsdruk van 5 bar is aangetoon dat 41% meer werk geproduseer kan word in vergelyking met die konvensionele sisteem waar daar slegs van 'n stoomsiklus gebruik gemaak word.

Aangesien die gevallestudies die belangrikheid van die drukverhouding oor die turbine uitgelig het, is eenvoudige wiskundige modelle gebruik om die invloed van drukverhouding op verskeie parameters in die sisteme te illustreer. Modelle is ontwikkel vir twee sisteme, naamlik 'n adiabatiese reaktor-skeidingsstelsel met 'n ewewigsreaksie en ook een wat reaksiekinetika insluit. Analise van albei modelle het getoon dat 'n hoë omsetting in die reaktor nie noodwendig lei tot optimale kragproduksie nie. Die parameter wat gemaksimeer moet word is die werk per molvloeï van die hersirkuleerstroom of per kg van die produk.

'n Belangrike resultaat van die meer effektiewe benutting van reaksiewarmte vir kragopwekking is 'n afname in die produksie van koolstofdiksied.

Gevolgtrekkings en aanbevelings

Vloeiskemas is belangrike gereedskap by die bestudering van chemiese reaksiesisteme met geïntegreerde ontspanningsturbinas. Die ontwikkeling van sulke vloeiskemas word verbeter indien die analogie tussen 'n chemiese reaktorsistelsel met ontspanningsturbine en 'n konvensionele krag siklus ingesien word. Prosesse wat met ontspanningsturbinas toegerus is benut die reaksiewarmte meer effektief vir kragopwekking in vergelyking met konvensionele sisteme.

Verskeie faktore het 'n invloed op die ontwikkeling van vloeiskemas vir chemiese reaksiesisteme met geïntegreerde ontspanningsturbinas, naamlik enkelstap of hersirkuleer bedryf van die reaksie, die reaksietoestande, die reaktor bedryf, die toestande vir skeiding van die produk en die fisiese eienskappe van die prosesgas. Die metodologie wat hier aangebied is neem hierdie faktore in ag en gee 'n gestruktureerde benadering tot die ontwikkeling van vloeiskemas vir prosesgas krag siklusse. In al die gevallestudies is die ontspanningsturbine suksesvol met die reaktorsistelsel geïntegreer en eksergieverliese is verminder. Daarmee is die doelwit van hierdie navorsing bereik.

Deur ontspanningsturbines te gebruik vir die herwinning van reaksiewarmte kan kragbesparing of addisionele kraglewering verkry word. Krag wat opgewek word kan intern deur die proses gebruik word of uitgevoer word. In beide gevalle word die produksie van CO₂ beperk. Ofskoon daar steeds kontroversie heers oor die verband tussen kweekhuiskasse en klimaatsverandering in sommige dele van die wêreld, sal handel in emissies waarskynlik realiseer. Toekomstige prosesontwerpe en ekonomiese evaluering van projekte sal hierdeur beïnvloed word.

Implementering van die verbeterde vloeiskemas wat hier aangebied is sal natuurlik afhang van die resultate van goeie ekonomiese evaluering. Met verwysing hierna is daar 'n behoefte om die konseptuele vloeiskemas verder te ontwikkel tot 'n vlak van detail wat realistiese ekonomiese evaluering moontlik maak. Eenvoudige ekonomiese evaluering is egter uitgevoer. Daar is aangetoon hoe die keuse tussen die maniere waarop addisionele krag gebruik word, naamlik vir uitvoer of interne gebruik, die resultaat van die ekonomiese evaluering beïnvloed.

Aangesien die resultate van al die gevallestudies positief was kan die direkte omskakeling van reaksiewarmte na elektrisiteit beskou word as 'n veel belowende konsep. Dit is egter noodsaaklik dat die vloeiskemas wat hier voorgestel is in meer detail ontwikkel word om betroubare ekonomiese evaluasies moontlik te maak.

Die konsep van 'n krag siklus wat prosesgas as werkvloeier gebruik behoort verder ontwikkel te word om sodoende die kombinasie van chemiese prosesse en krag siklusse op hierdie geïntegreerde vlak te bevorder. 'n Gestruktureerde benadering tot die ontwerp van chemiese prosesstelsels is waardevol en verbeter verseker die resultaat.

Samenvatting in Nederlands

Het doel van dit proefschrift is het uitvoeren van een studie naar de integratie van turbine expanders met chemische reactoren waarin exotherme reacties bij hoge druk en temperatuur worden uitgevoerd. Op deze manier wordt de reactiewarmte direct omgezet in elektrische energie. Dit proefschrift beschrijft een unieke benadering om chemische reactoren te koppelen met een vermogens cyclus.

De reactiewarmte van exotherme reacties wordt gebruikelijk door warmtewisseling afgevoerd naar een andere medium, zoals water en stoom. Op deze wijze wordt de kwaliteit van de warmte echter verlaagd. De stoom wordt dan verder gebruikt voor de verwarming van processen en het opwekken van elektrisch energie via een stoomturbine. Warmte heeft echter een hogere kwaliteit bij hogere temperatuur. Volgens de tweede hoofdwet van de thermodynamica is het efficiënter om de warmte geproduceerd in reactoren zoals hierboven bedoeld, direct om te zetten in elektrische energie. In dergelijke geïntegreerde systemen, waarin de reactor effluent dient als proces medium, worden zowel elektriciteit als chemische product(en) geproduceerd. Een efficiëntere omzetting van de reactiewarmte in elektrische energie kan ook milieuvordelen opleveren, zoals een verlaging van de CO₂, NO_x en SO₂ emissies.

Turbine expanders, met uitsluiting van stoom en verbrandingsgas turbines, zijn zeer efficiënte turbines. Veel van de expanders voor koolwaterstoffen zijn ontworpen voor energiewinning waarbij de compressor op dezelfde as is bevestigd. De literatuur geeft aan dat de turbine expander technologie volwassen is en dat maatwerk kan worden geleverd met betrekking tot verschillende omstandigheden. Temperaturen tot 870°C worden toegepast bij turbine vermogens in het gebied variërend van 75 kW tot 10 MW en zelfs tot 130 MW. Een ontwerp voor condenserende gasstromen en suspensies behoren tot de mogelijkheden.

Voorbeelden van integratie van turbine expanders met chemische processen zijn zeldzaam en worden praktisch uitsluitend beschreven in de patent literatuur. Het literatuuroverzicht in dit proefschrift laat zien dat turbine expanders in de plant worden geplaatst daar waar de invloed op het proces minimaal is. Dit betekent voordat de voeding de reactor in gaat. Indien echter een dergelijke expander in de uitlaat van de reactor wordt geplaatst is er wel sprake van een invloed, met name als de niet omgezette reactanten worden teruggevoerd in de reactor.

Een aantal patenten over de combinatie van gas turbines met chemische plants of een integratie van expanders met processtromen is gepubliceerd. Echter slechts drie patenten zijn bekend waarbij een expander direct aan een exotherme reactor is gekoppeld. Het concept van expanderend product gas is daarom nieuw te noemen en onderzoek is nodig om het concept verder uit te werken en het vinden van toepassingen.

Dit vraagt dus om een ontwerp methodologie voor flow sheet configuraties ten behoeve van chemische processen waar een expander kan worden toegepast. Dit proefschrift beschrijft de ontwikkeling van een dergelijke methodologie. Hierbij worden de parameters en hun rol in het ontwerp vastgesteld. Tenslotte worden criteria voor de uitvoering en een aantal praktische aspecten onderzocht en beschreven.

Methode

Het onderzoek is uitgevoerd via de lijn van conceptuele case studies aan verschillende chemische processen. Deze processen hebben gemeen dat ze exotherm zijn en plaatsvinden onder verhoogde druk. Ze verschillen echter in het bedrijven van de reactor, scheidingstechnieken, conversie etc. Voorbeelden van bekende processen worden gebruikt ten behoeve van de modellering. Proces data worden verkregen door gebruik te maken van simulaties. Het niveau van de modellering is conceptueel om zodoende de fundamentele principes, relaties en gevolgen te bestuderen.

De resultaten van deze studies zijn veel belovend met betrekking tot grotere energiebesparing in het geïntegreerde proces vergeleken met die in het proces zonder integratie. De resultaten van de studies dragen bij tot een beter begrip over het gedrag van geïntegreerde systemen van een chemische reactor en een turbine expander. Daarnaast is gewerkt aan de ontwikkeling van mathematische modellen om twee typische systemen, namelijk een adiabatisch bedreven scheidingssysteem met een evenwichts gelimiteerde en een met een kinetisch gelimiteerde reactie.

Resultaten

Het belangrijkste resultaat van dit onderzoek is een methodologie die het mogelijk maakt de ontwikkeling en analyse van flow sheets voor chemische processen gekoppeld aan een expander te beschrijven. De toepassing van de methodologie is geïllustreerd door verschillende case studies. Als eerste wordt in deze benadering het systeem, chemische reactor met expansieturbine en haar analogon, een conventioneel systeem voor conventionele elektriciteitsopwekking vergeleken. Als tweede worden synergistische effecten geïdentificeerd en toegepast om het ontwerp te verbeteren. Op de derde plaats worden systeemgrenzen gedefinieerd waarbij systemen worden bekeken in plaats van afzonderlijke unit operations. Bovendien dienen aan de systeemeisen van zowel het chemisch proces als het energie opweksysteem te worden voldaan. Deze benadering vormt de basis voor een methodologie waarbij structuur wordt gegeven aan de ontwikkeling en analyse van processchema's van dergelijke systemen. In de methodologie worden verschillende factoren gebruikt die van invloed kunnen zijn op de ontwikkeling van flow sheets bij het procesontwerp. Deze factoren zijn: het bedrijven van de reactor met en zonder recycle, reactie condities, randvoorwaarden bij de in te zetten scheidingstechnologie en de fysisch-chemische eigenschappen van het procesgas. De invloed van deze factor is onderzocht. Indien een

bepaalde ontwerpconfiguratie is vastgesteld wordt de analyse van dit ontwerp ingezet voor het vinden van een bruikbare set van flow-sheet condities.

Een aantal conceptuele ontwerp studies met betrekking tot verschillende gangbare chemische processen wordt gepresenteerd. Deze zijn de productie van: ftaalzuuranhydride, ammoniak, methanol, ethyleenoxide en synthese gas. De studies geven aan dat een belangrijke energiebesparing kan worden bereikt in vergelijking met de conventionele processen.

In geval van de productie van ftaalzuuranhydride worden twee mogelijkheden voor warmtewinning vergeleken. Beide opties hebben een stoomcyclus. De smookklep in het conventionele systeem wordt vervangen door een expander. In afwezigheid van een dergelijke expander is het wel mogelijk om alle compressiearbeid te laten leveren door een juiste keuze van de procescondities. Het resultaat van de toepassing van een expander geeft aan dat extra elektriciteit kan worden opgewekt.

In de case studie over methanol wordt een nieuw procesontwerp dat de reactiewarmte meer efficiënt toepast ontwikkeld. Hierbij is een stoom cyclus gecombineerd met een proces gas cyclus, waarbij de reactiewarmte over beide cycli verdeeld wordt. Zelfs het hoge-druk purge gas wordt geëxpandeerd om arbeid terug te winnen. Het conventionele en het nieuwe verbeterde proces worden vergeleken op basis van de geleverde arbeid per kg product. De energievraag van het conventionele proces met een isotherme reactor kan met 43% worden gereduceerd bij toepassing van het nieuwe systeem. Dit wordt voornamelijk bewerkstelligd indien een gedeelte van de energie wordt ingezet als compressor arbeid. Het totale systeem geeft nog een extra reductie van 24%.

Ten behoeve van de productie van ammoniak zijn twee alternatieve en verbeterde processen ontworpen. Bij de ammoniak synthese wordt een recycle loop gebruikt en een afscheiding van het product bij lage temperatuur. De drukverhouding over de expander blijkt een belangrijke rol te spelen in de optimalisatie van een geïntegreerd systeem, met name omdat hier een evenwichtssituatie een rol speelt. De drukverhouding beïnvloedt de inlaat-temperatuur van de reactor. Deze verandering beïnvloedt op zijn beurt weer de conversie en daarom ook de hoeveelheid reactiewarmte die beschikbaar is voor de conversie in elektrische energie. Met behulp van een gevoeligheidsanalyse wordt de drukverhouding bepaald voor de minimale hoeveelheid arbeid per kg product en tevens het minimale exergieverlies per kg product.

Een van de twee voorgestelde ontwerpen laat een verbetering zien van 75% ten opzichte van het conventionele proces met betrekking tot de minimale hoeveelheid in te zetten arbeid per kg product. Hierbij wordt ook de energie penalty voor de afkoeling benodigd voor de scheiding betrokken. Dit ontwerp laat ook een afname van het exergieverlies zien. Het verlies is ook meer verdeeld over de verschillende unit operations.

Een ontwerp voor de synthese van ethyleenoxide waarmee zowel stoom als elektrische energie wordt beschreven. Hierbij dient wel de reactordruk verhoogd te worden. Dit om de inzet van de expander mogelijk te maken. De energieconsumptie daalt van 1 064 kJ/kg ethyleenoxide naar 688 kJ/kg ethyleenoxide.

De laatste ontwerpstudie van een turbine expander wordt toegepast bij de productie van synthese gas door middel van autothermale reforming. De hoge-temperatuur warmte van het synthese gas wordt efficiënter benut in een gecombineerde cyclus. De netto beschikbare hoeveelheid arbeid van het geïntegreerde systeem neemt toe met een toename van de drukverhouding over de expander. Bij een expansiedruk van 5 bar wordt 41% meer arbeid geproduceerd vergeleken met het conventionele systeem waarbij uitsluitend stoom wordt gebruikt.

De ontwerpstudies wijzen uit dat de drukverhouding over de expander belangrijk is terwijl de mathematische modellen de invloed van de drukverhouding op een aantal parameters in de cycli aangeven. Twee modellen zijn ontwikkeld, namelijk een voor een adiabatische reactor waarin een evenwichts gelimiteerde reactie wordt uitgevoerd en een waarbij het gaat om een kinetiek gelimiteerde reactie. Bepaald werd dat een hoge conversie in de reactor niet noodzakelijkerwijs bijdraagt aan een hogere energieopbrengst. Echter, de parameter die maximaal moet worden is de arbeid per hoeveelheid gerecirculeerde hoeveelheid effluent.

Een belangrijk resultaat bij het meer efficiënt gebruiken van de reactiewarmte is de verlaging van de emissie van kooldioxide.

Conclusies en aanbevelingen

Flow sheets zijn gebleken belangrijke gereedschappen te zijn bij de bestudering van chemische reactor systemen gekoppeld aan een expander en conventionele systemen voor de opwekking van elektriciteit. Processen die uitgerust zijn met een expander gaan beter om met de kwaliteit van de energie dan de conventionele systemen.

Factoren zoals: omzetting met of zonder recycling, reactie condities, condities voor scheiding en de fysische eigenschappen van het proces gas hebben invloed op de ontwikkeling van processchema's van chemische systemen geïntegreerd met een turbine expander. De hier beschreven methodologie beschouwt deze factoren en geeft een structurele benadering tot de ontwikkeling van processchema's waarin de opwekking van elektriciteit beschreven wordt. Bij alle case studies is vastgesteld dat de expander succesvol kan worden geïntegreerd en dat daarmee exergie verliezen kunnen worden beperkt. Daarmee is voldaan aan de doelstelling van het onderzoek.

Energiebesparing of elektriciteitsproductie kan worden bereikt door het toepassen van een expander. Geproduceerde elektriciteit kan worden ingezet in het proces zelf of worden

geëxporteerd. Hierbij kan de uitstoot van CO₂ worden beperkt. Ofschoon er in sommige delen van de wereld nog steeds controversieel gedacht over de relatie broeikasgassen en klimaatverandering is het traject naar emissiehandel van deze gassen al ingezet. Dit beïnvloedt het toekomstig procesontwerp en de economische evaluatie van projecten in de chemische industrie in hoge mate.

Het al of niet implementeren van de verbeterde ontwerpen zal afhangen van de resultaten van economische evaluaties. Hierbij dient het conceptuele procesontwerp verder te worden ontwikkeld tot detailed engineering. Echter een eenvoudige economische analyse wordt omschreven. Aangetoond is dat de manier waarop additioneel geproduceerd vermogen wordt ingezet, intern of extern de resultaten van de economische evaluatie duidelijk beïnvloed.

Daar alle uitkomsten van de case studies positief zijn kan worden geconcludeerd dat de directe omzetting van reactiewarmte in elektriciteit veel belovend is. Voor een verder toepassing is het wel noodzakelijk dat er economische evaluaties worden uitgevoerd die wat detail betreft verder gaan dan dat wat hier beschreven is.

Het concept, de combinatie van een chemische reactor met een expander, kan in meer detail ontwikkeld worden waar de ontwikkelde methodologie kan worden ingezet.

Contents

Chapter 1 Introduction

1.1	Background, purpose and motivation.....	1
1.2	Scope and outline	3
1.3	References	5

Chapter 2 Integrated power and chemicals production systems

2.1	Levels of system integration.....	8
2.2	Chemical processes integrated with energy conversion devices.....	9
2.2.1	Steam boilers	9
2.2.2	Combination of combustion gas turbines with chemical processes.....	10
2.2.3	Combination of turbine expanders with chemical processes	11
2.3	Power systems incorporating chemical unit operations	18
2.3.1	Catalytic reactions in the expansion space of gas turbine	18
2.3.2	Chemically recuperated gas turbine	18
2.3.3	Combined cycle with partial oxidation to produce synthesis gas	19
2.3.4	Reactor expander topping cycle	20
2.4	Power systems and chemical plants, integrated at the process level.....	21
2.5	Conclusions	23
2.6	References	23

Chapter 3 Flow sheet design and analysis for process gas power cycles

3.1	Introduction to the concept of direct conversion of reaction heat to power.....	29
3.2	Combining a chemical reaction system and a power cycle.....	31
3.2.1	Basis for a flow sheet design methodology – a novel approach	31
3.2.2	Chemical reaction systems	33
3.2.3	Power generation systems	35
3.2.4	A generic example of combining a chemical reaction system and a power cycle.....	40
3.2.5	Thermodynamics, chemistry and physics relevant to a reactor coupled to a turbine expander	42
3.3	Methodology for developing and analysing the flow sheets of integrated systems.....	44

3.3.1	Methodology overview.....	44
3.3.2	Factors impacting on the flow sheet structure.....	45
3.4	Mathematical modelling of flow sheets	49
3.4.1	Adiabatic reaction system with equilibrium-limited reaction	49
3.4.2	Adiabatic reaction system with reaction kinetics	55
3.4.3	Adiabatic reaction system with reaction kinetics and no recycle.....	56
3.5	Flow sheet design parameters.....	57
3.5.1	Heat input and thermal efficiency	57
3.5.2	Expander and compressor inlet temperatures.....	57
3.5.3	Gas flow rate and composition.....	58
3.5.4	Pressure ratio	58
3.5.5	Volume change during chemical reaction	64
3.5.6	Specific heat ratio of working fluid.....	68
3.5.7	Isentropic efficiency	73
3.5.8	Operation window	73
3.6	Process design criteria for turbine expander integration	74
3.7	Conclusions	75
3.8	References	76

Chapter 4 Using turbine expanders to recover exothermic reaction heat – a case study on a phthalic anhydride process

4.1	Introduction	80
4.2	Literature survey.....	81
4.3	Process modelling.....	85
4.4	Results and discussion.....	88
4.5	Conclusions	92
4.6	References	93

Chapter 5 Utilisation of reactor heat in methanol synthesis to reduce compressor duty – application of power cycle principles and simulation tools

5.1	Introduction	97
5.2	Conventional methanol production	98
5.3	Development of a new flow sheet through application of power cycle principles	99
5.4	Simulation models.....	101

5.5	Simulation results and discussion.....	103
5.6	Conclusions	105
5.7	References	105

Chapter 6 Integration of a turbine expander with an exothermic reactor loop – flow sheet development and application to ammonia production

6.1	Introduction	109
6.2	Direct conversion of reaction heat to electrical energy	110
6.3	Conventional ammonia production	113
6.4	Ammonia synthesis system integrated with a turbine expander	114
6.5	Simulation models.....	117
6.6	Simulation results and discussion.....	119
6.7	Conclusions	123
6.8	References	124

Chapter 7 Recovering of reaction heat in the oxygen-based synthesis of ethylene oxide

7.1	Conventional ethylene oxide production process.....	128
7.2	Development of a flow sheet integrated with a turbine expander.....	131
7.3	Simulation models.....	134
7.4	Results and discussion.....	136
7.5	Conclusions	140
7.6	References	140

Chapter 8 Expansion of synthesis gas to produce power

8.1	Synthesis gas generation for natural gas conversion.....	144
8.2	Utilisation of high temperature heat from synthesis gas	145
8.3	Retrofitting a conventional ATR process scheme with a turbine expander	147
8.4	Simulation models.....	150
8.5	Simulation results and discussion.....	151
8.6	Conclusions	152
8.7	References	152

Chapter 9 Using turbine expanders to recover exothermic reaction heat – flow sheet development for typical chemical processes

9.1	Introduction	156
9.2	Methodology for developing and analysing the flow sheets of integrated systems...	157
9.3	Gas power cycles and chemical reaction systems	158
9.4	Factors impacting on the flow sheet development	162
9.5	Case studies	165
9.6	Conclusions	173
9.7	References	174

Chapter 10 Practical aspects of turbine expander integration

10.1	Requirements for implementation of the idea	175
10.2	Economic evaluation	176
10.3	Exergy analysis.....	181
10.4	Environmental benefit	182
10.5	Turbine expander equipment and practical design considerations.....	184
10.6	References	186

Chapter 11 Conclusions and outlook 187

Publications..... 191

Curriculum vitae 193

Chapter 1

Introduction

1.1 Background, purpose and motivation

In the chemical process industry there is usually a great demand for heat and power. Combination of chemicals, heat and power production should therefore lead to improved system efficiency due to synergistic effects (Dijkema et al., 1998). Combined production of heat and power (CHP) has become a widely used technology for the improvement of the thermodynamic performance of energy conversion. It is regarded as an attractive technology from an economic and environmental viewpoint (Korobitsyn, 1998).

There are various ways that the production of power and chemicals can be combined, ranging from a single energy conversion device integrated into a chemical process to a production complex comprising a petrochemical plant and a cogeneration facility, which delivers part of its power to a public grid. Examples of energy conversion devices integrated into chemical processes are steam boilers, expansion turbines and furnaces (Dijkema et al., 1998). Integration of a steam methane reformer with various power generation technologies, including cogeneration, has already been demonstrated commercially (Terrible et al., 1999).

The purpose of this work is to study the integration of turbine expanders with exothermic, high-pressure gas-phase chemical reactor systems for direct conversion of the reaction heat into electrical energy. The reaction heat of exothermic reactions is typically transferred by heat exchange to another medium for use at a different location, and thereby also downgraded in quality. Steam raising systems are common practice. The steam may be exported, used for process heating or to generate power in steam turbines, either for export or process requirements.

Heat is, however, more valuable or of a higher quality, the further its temperature is from the ambient. From a Second Law or exergetic viewpoint, it is therefore more efficient to recover reaction heat by direct expansion of the hot, high-pressure product gas in a turbine expander. The additional step of transferring the heat to another medium, and the associated losses, is avoided. The reaction heat is utilised at the maximum possible temperature to produce power *using the process gas as the working fluid*. A process gas power cycle is created that also delivers a chemical product. This process gas power cycle will include a number of unit operations needed to complete a thermodynamic cycle. The concept of a process gas power cycle versus a utility fluid power cycle is best illustrated by using *heat engines*, as shown in Figure 1.1. An amount of reaction heat is available from the reactor. This heat is already contained in the process gas (Q_{PG}) and the process gas cycle therefore utilises the heat at the

temperature of the reaction (T_{PG}) to produce power. The utility fluid power cycle, however, receives the same quantity of heat ($Q_{UF} = Q_{PG}$), but at a lower temperature (T_{UF}) due to the driving force needed to transfer the heat from the process gas to the utility fluid. It follows that, for reversible power cycles, the process gas power cycle has a higher Carnot efficiency compared to the utility fluid power cycle and therefore has the potential to produce more power from the same quantity of heat. This more efficient conversion of the reaction heat to electricity also translates into a benefit to the environment, due to decreased emissions of CO_2 , NO_x and SO_x associated with power generation from fossil fuels.

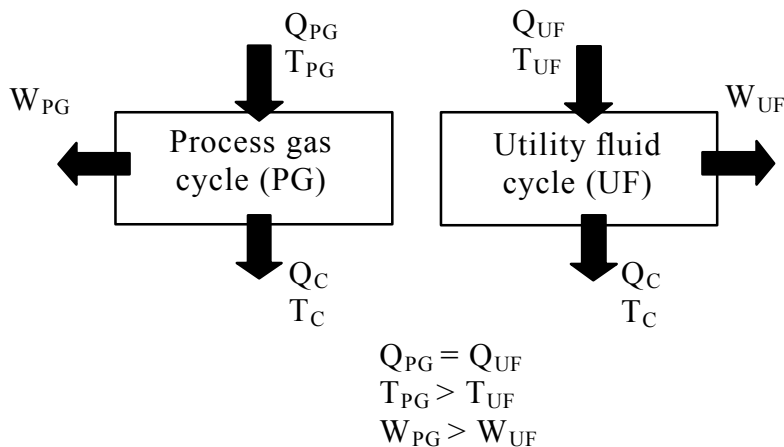

Figure 1.1 Process gas power cycle versus utility fluid power cycle for the utilisation of reaction heat.

Process gas power cycles will typically make use of highly efficient turbine expanders that specifically exclude steam and combustion gas turbines. Most of the hydrocarbon gas expanders are designed for power recovery and can be directly connected to a process compressor on the same shaft (Bloch, 2001a). Power recovery applications are also on the increase, mainly due to a change in market conditions driven by growing environmental awareness and an increase in power costs (Bloch, 2001b).

In most combined chemicals and power production systems the working fluid of the energy system and the process fluid are separated. This suits the traditional approach of labelling energy supply to and withdrawal from a process as ‘utilities’ and designing the utility system separately as an add-on to the core process. Although turbine expanders may use process fluid as a working fluid, most expanders are placed in tail gas, flue gas or purge gas streams where they do not impact highly on the process operation itself. *Direct expansion of reactor product gas to recover reaction heat may impact significantly on downstream operations, optimum process conditions or even process configuration.* In cases where the impact of the turbine expander is not significant, it may be possible to retrofit an existing process, but otherwise process changes may be necessary, leading to a new flow sheet configuration.

A number of patents on the combination of gas turbines with chemical plants or integration of turbine expanders directly with process streams have been issued. Up to date only three patents could be found that deal with a turbine expander placed directly behind an exothermic reactor. Janssen et al. (1997) patented a concept for the production of ethane from methane. Exothermic catalytic combustion takes place in the combustion chamber of a gas turbine with the exhaust products driving a turbine to compress the reactants and produce electricity.

Rao (1991) suggested that an exothermic reactor and a turbine expander be placed before a gas turbine or fuel cell. Feed gases are allowed to react exothermically to produce a gaseous product that can be used for power generation in the downstream gas turbine or fuel cell. The heat given off during the said reaction is recovered as power in the intermediate turbine expander. Recently Agee et al. (2000) patented a synthesis gas production system wherein an autothermal reformer is placed between a compressor and expander. The autothermal reformer produces synthesis gas and also serves as the combustor of the gas turbine system.

The concept of expanding hot reactor product gas is therefore new and an investigation is needed to generalise the concept and find further applications.

1.2 Scope and outline

It is evident that a unique design approach or methodology is needed to develop flow sheet configurations for chemical reaction systems that use turbine expanders to recover reaction heat. It is the aim of this work to address this need by finding a methodology that will lend structure to the development and analysis of the flow sheets for the mentioned systems. Many factors have to be taken into consideration, both relating to the requirements of the chemical process and the requirements of the power cycle created using the process gas. For example, a reasonable pressure ratio is required over compression equipment in the case of a power cycle to produce power efficiently. The physical properties of the process gas, which becomes a working fluid, are also important. Furthermore, a thorough understanding of the role and behaviour of the expander within the chemical process is needed. Consequently, in this work the parameters that impact on the integrated systems will be identified and their roles investigated.

Suitable criteria of performance for the integrated systems in question are also needed. In this regard the exergy method is particularly suited since it enables designs that will use energy resources more efficiently. The application of exergy analysis is illustrated and the strengths and limitations are discussed.

The purpose of this research is achieved by conducting a number of case studies on different chemical reaction processes. These processes all comprise exothermic, high-pressure reactions, but otherwise differ significantly in terms of aspects such as reactor operation,

separation techniques, reactant conversion etc. The chemicals are also produced on a global scale using well-known processes. This makes realistic modelling of the processes possible. Process data are generated using simulations. The level of modelling and simulation is of a conceptual nature to investigate and illustrate fundamental principles, relations and trends.

The thesis is outlined as follows:

In Chapter 2 an overview of the literature on integrated production systems that involve gas turbines and turbine expanders is given. Most of the examples of processes incorporating turbine expanders are from patent literature and a classification of these systems is made.

Chapter 3 focuses on the design and analysis of flow sheet configurations for chemical reaction systems integrated with turbine expanders. A novel approach to combine a chemical reaction system with a power cycle using an expansion turbine is presented. This approach forms the basis for a subsequent method to lend structure to the development and analysis of the flow sheets for the mentioned systems. To aid in flow sheet analysis simplified mathematical models are developed for typical process gas power cycles.

In Chapters 4 to 8 five case studies on different chemical processes are presented, namely phthalic anhydride, ammonia, methanol, ethylene oxide and natural gas reforming for synthesis gas production. The case studies on phthalic anhydride, ammonia and methanol have been published as scientific papers and are included as such as chapters. These can be read as self-contained units.

Chapter 9 comprises a scientific paper on the development of flow sheets for processes integrated with turbine expanders. In this paper the methodology presented in Chapter 3 is briefly given and its application is illustrated with reference to the first four case studies (excluding the synthesis gas production case). The paper gives a short overview and summary of the results of the cases and also stresses the differences between the cases. Note that the approach to include published papers in the thesis inevitably causes repetition of certain sections.

Chapter 10 is a general discussion on practical aspects of turbine expander integration ranging from requirements for implementation to economic evaluation and mechanical design aspects.

Chapter 11 gives the conclusions and outlook.

1.3 References

Agee MA, Weick LJ, Agee KL and Trepper EL, “Synthesis gas production system and method”, *US Patent 6155039*, assigned to Syntroleum Corp (US), 2000.

Dijkema GPJ, Luteijn CP, Weijnen MPC, “Design of trigeneration systems”, *Chemical Engineering Communications*, vol. 168, pp. 111-125, 1998.

Bloch HP, “Consider turbo-expanders” (Editorial Comment), *Hydrocarbon Processing*, vol. 80, no. 1, p. 1, 2001a.

Bloch HP, “Become familiar with turbo-expander applications” (Reliability), *Hydrocarbon Processing*, vol. 80, no.2, pp. 17-18, 2001b.

Janssen FJJG, Verkooijen AHM and Ploumen PJ, “Synthesis of ethane”, *European Patent 0753652*, assigned to N.V. Kema, The Netherlands, 1997.

Rao AD, “Reactor expander topping cycle”, *US Patent 4999993*, assigned to Fluor Corporation, United States, 1991.

Terrible J, Shahani G, Gagliardi C, Baade W, Bredehoft R and Ralston M, “Consider using hydrogen to cogenerate power needs”, *Hydrocarbon Processing*, vol. 78, no. 12, 1999.

Chapter 2

Integrated power and chemicals production systems

The production of power and chemicals can be combined in many ways. This chapter considers integrated production systems that involve gas turbines and turbine expanders. The literature review resulted in the identification of three types of relevant integrated systems, namely chemical plants combined with energy conversion devices, power systems incorporating chemical unit operations as well as production complexes that produce synthesis gas for combined chemicals and power production. The review is organised according to these three types of systems.

The type of system that is the subject of the thesis is considered under chemical plants combined with energy conversion devices. Not many examples of the integration of expansion turbines with chemical process streams can be found in conventional literature, most of the process examples reviewed here are therefore taken from patent literature. A study of the various process examples lead to the realisation that the type of process gas stream that is used for the turbine expander is significant in determining the impact of the expander on the process operation. The various examples of processes incorporating turbine expanders are therefore categorized according to the type of process gas used for expansion.

Nomenclature

Flow sheet abbreviations

ATR	Autothermal reforming
B	Blower
BFW	Boiler feed water
C	Compressor
CHP	Combined heat and power
GTL	Gas to liquids
HEX	Heat exchanger
HRSG	Heat recovery steam generator
IGCC	Integrated gasification combined cycle
R	Regenerator
SMR	Steam methane reforming
ST	Steam turbine
T	Turbine expander

2.1 Levels of system integration

Combined production of heat and power (CHP) is widely used for the improvement of the thermodynamic performance of energy conversion. CHP is also referred to as *cogeneration*. Various configurations are available to satisfy process and space heating needs and the technology is seen as attractive from an economic and environmental point of view (Korobitsyn, 1998).

In the chemical process industry there is usually a great demand for heat and power. Combination of chemicals, heat and power production should therefore lead to improved system efficiency due to synergistic effects (Dijkema et al., 1998).

There are various ways that the production of power and chemicals can be combined. Dijkema et al. (1998) made a valuable distinction between different levels of system-integration for what is referred to as *trigeneration systems* for power, heat and chemicals. These levels are shown in Table 2.1. *Note that the term trigeneration is also sometimes used in the field of mechanical engineering for systems that produce heat, power and cooling.*

Table 2.1 System integration levels for trigeneration systems (Dijkema et al., 1998).

Level	Description
1	Components
2	Unit operation
3	Chemical plants, Power systems
4	a) Chemical plants + energy conversion device b) Power system + chemical unit operation
5	Power systems and chemical plants, integrated at the process level

A gas turbine can be considered a multifunctional unit operation or level 2 system, comprising level 1 components, namely a compressor and expander on a single shaft. A single chemical plant or stand-alone power plant is a level 3 system. Two types of level 4 systems are possible, namely chemical plants with integrated energy conversion devices or power systems that include chemical unit operations. Level 5 systems are ones in which chemical plants and power plants are combined as distinct processes. An example of a level 5 system is a production complex comprising a petrochemical plant and a cogeneration facility, which delivers part of its power to a public grid (Dijkema et al., 1998).

Using the system classification of Dijkema et al. (1998), an expansion turbine combined with an exothermic, high-pressure gas-phase chemical reactor would be a level 4 system. However, whether the system is a chemical process combined with an energy conversion device (level 4a) or a power system including a chemical unit operation (level 4b), is less obvious. This will depend on system boundaries and on how the combined system is developed, i.e. whether one starts with a power cycle or a chemical process. Although the combustion step in a power plant is a chemical reaction, the system is not classified as level 4 since power is the only product of the system.

The subsequent focus of this chapter is on level 4 type systems, and more specifically those that involve gas turbines and turbine expanders. Reference is made to general literature wherein such systems are described and analysed as well as patent literature wherein many interesting concepts are found. Chemical plants combined with energy conversion devices as well as power systems incorporating chemical unit operations are considered.

2.2 Chemical processes integrated with energy conversion devices

The use of energy conversion devices integrated into chemical processes is still limited. Commonly found examples are steam boilers, expansion turbines, gas turbines and furnaces (Dijkema et al., 1998). In most of the cases the integration is done via heat transfer. This means that the flows of the energy system and process system are not physically connected. This suits the traditional approach of labelling energy supply to and withdrawal from a process as ‘utilities’ and designing the utility system separately as an add-on to the core process.

2.2.1 Steam boilers

Boilers are used to produce steam for process heating. Process waste heat can be used to produce additional steam for export or power generation in steam turbines. An example is steam methane reforming (SMR) plants that are designed to produce hydrogen, but can also economically produce steam and power. A large amount of waste heat is available from the reformer furnace to produce steam. The integration of SMR with topping and condensing steam turbine has been demonstrated commercially (Terrible et al., 1999).

2.2.2 Combination of combustion gas turbines with chemical processes

Note that according to the system classification of Dijkema et al. (1998), a gas turbine can be considered a multifunctional unit operation or level 2 system, comprising level 1 components, namely a compressor and expander on a single shaft.

Integration of gas turbines into existing process sites are one of the more common examples of energy conversion devices combined with chemical processes. It is not a trivial task and involves simultaneous design of a gas turbine system and retrofit of an existing process to accommodate the gas turbine. The options for integration of a gas turbine into an existing site can be classified into four main schemes (Manninen & Zhu, 1999), also shown in Figure 2.1:

1. use the gas turbine exhaust to raise steam in a heat recovery steam generator (HRSG);
2. use the gas turbine exhaust as combustion air in a furnace or boiler;
3. use the gas turbine exhaust directly for process heating or
4. use the gas turbine as a direct or indirect process driver.

The first two schemes are the most common ones. Terrible et al. (1999) reports on a case of an SMR furnace integrated with as gas turbine as well as another case of an SMR combined with a gas turbine and topping steam turbine. These plants are in operation and the authors also report on the economics of the plants.

Albano et al. (1992) reports on the application of a gas turbine connected to a steam cracker furnace as an attractive option to reduce the energy requirements per unit of ethylene production. The gas turbine exhaust is used as combustion air in the furnace. The total flue gas passing through the furnace is however increased due to the reduced oxygen content of the turbine exhaust gas compared to air. Steam production in the convection section of the furnace is therefore increased.

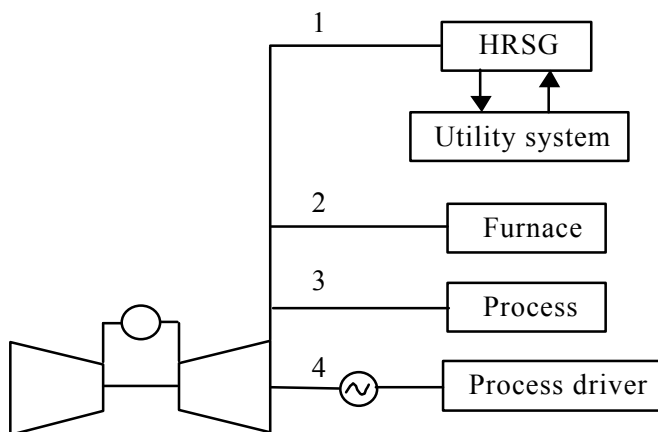

Figure 2.1 Options for integrating a gas turbine into an existing site (Manninen & Zhu, 1999).

2.2.3 Combination of turbine expanders with chemical processes

Turbine expanders are high efficiency turbines that specifically exclude steam and combustion gas turbines. *Note that according to the system classification of Dijkema et al. (1998), a turbine expander is a level 1 component.*

Most of the hydrocarbon gas expanders are designed for power recovery and can be directly connected to a process compressor on the same shaft (Bloch, 2001a). These machines have been used in air separation processes since the mid-1950's to provide low-temperature refrigeration. Power recovery used to be of secondary importance, but the number of power recovery applications is on the increase. Currently, turbine expanders are mostly used in air-separation to expand down from 5 bar and in hydrocarbon processing plants to expand natural gas from as high as 200 bar (Bloch, 2001b).

This literature review revealed that turbine expanders that are integrated into chemical processes are mostly placed in tail gas, flue gas or purge gas streams. These gas streams may be seen as side streams of the process that are not critical to the process operation itself and therefore expansion of these streams should not impact highly on the process. Tail gas, flue gas and purge gas streams are also usually final streams leaving the process boundary, they are not processed further in downstream unit operations and also do not contain the main chemical product of the process. The flows of the energy system and process system are, however, physically connected and the integration is not done via heat transfer, as is the case with gas turbine and steam turbine integration.

Note that few examples exist of expansion turbines used for direct expansion of reactor product gas to recover reaction heat. In such systems the turbine expander may impact significantly on downstream operations, optimum process conditions and even the process configuration. The process gas used as a working fluid will often be in an intermediate stage of processing, en route to downstream unit operations, for example separation or purification. The process gas will contain the main chemical product of the process and may also be used as a feedstock for another process.

It is evident that the type of process gas stream that is used for the turbine expander is significant in determining the impact of the expander on the process operation. For this reason the various examples of systems from literature described next have been categorized according to the type of process gas used in the expander.

Flue gas expanders

In the case of flue gas expansion, the turbine expander does not use process gas directly but rather another gas that is closely associated with the process. A well-known and commercially performed example is the power recovery turbines used in fluidised catalytic cracking (FCC) units. The power recovery turbine expander is placed in the flue gas stream of the FCC catalyst regenerator.

Goulden (1968) patented the system wherein power is recovered from FCC flue gas and then used to supply pressurised air to the FCC regenerator. The regenerator is under super atmospheric pressure and the flue gas is first passed through a dust separating system for removal of fine catalyst particles from the gas. A simplified diagram of a part of the system is shown in Figure 2.2. The turbine expander (T) is used to drive an air blower (B1) and a generator. The electric power from the generator is used to drive a booster air blower (B2) that receives air from a set of steam turbine driven air blowers (not shown). The steam is generated in a boiler that is partly fed with the turbine expander exhaust gas (carbon monoxide). In this way maximum sensible and combustion heat is recovered from the flue gas.

A patent granted to Fink (1982) describes how the air supply system of an FCC regenerator is linked to a gas driven turbine, i.e. a cogeneration process. The air supply system also supplies a pressurized air stream to the turbine of a power plant. The air compressor is driven by the regenerator flue gas power recovery expander, as described in the patent by Goulden (1968). The pressurised air is preferably first heated against the turbine exhaust and then mixed with hot gas from separate turbine type gas generators before being passed to the turbine.

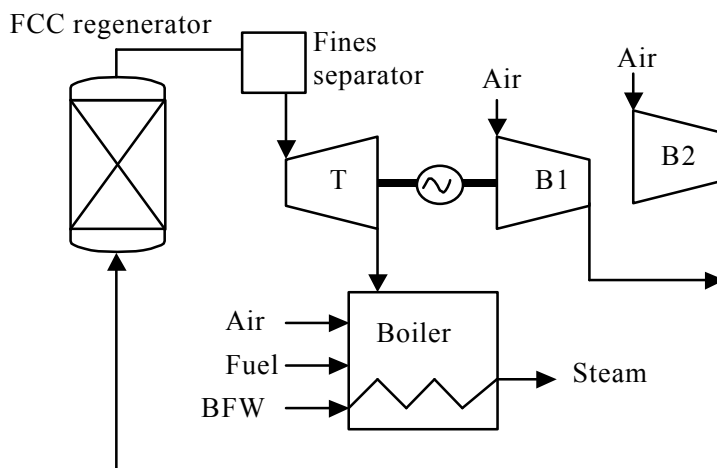

Figure 2.2 Schematic showing part of the invention by Goulden (1968).

Turbine expanders are also used to recover energy from blast furnace exhaust gas. Shirato (1981) patented a method and apparatus for recovering energy by utilising an axial-flow

turbine. According to the method, the adhesion of dust to the turbine is effectively prevented, by making the flow-out direction of the nozzle outlet in agreement with the gas flow-out direction at the moving blade outlet of the turbine.

Tail and purge gas expanders

Tail gas is the gas stream leaving a reactor system that does not contain the desired chemical product. Such a gas stream may contain an amount of unconverted reactants that is often recycled to the reactor or it may contain unwanted by-products of the reaction. When the tail gas is recycled to the reactor, an amount of gas, referred as purge gas, is usually removed from the recycle system to prevent build-up of inert components that may hinder the reaction. Expansion of recycle tail gas will have a larger impact on the process operation compared to the expansion of tail gas since non-recycled tail gas does not undergo further upstream processing.

A classic example is the tail gas expanders in the nitric acid manufacturing process. Nitric acid is manufactured in the Ostwald process. First the oxidation of ammonia takes place over a platinum catalyst:



followed by the further oxidation of NO to NO₂:



NO₂ is then absorbed into water to give the acid and NO, which is recycled back into the process:



The first reaction (2.1) is carried out at temperatures between 700 and 1000°C and pressures from 1 to 3 bar. Higher pressures are unfavourable to this step. The second reaction (2.3) takes place in an absorption column at low temperatures of about 25°C and at pressures between 4 and 8 bar. Horton (1969) patented a process in which the high temperature heat of the reaction gases from the low-pressure oxidation stage is transferred to the high pressure, low temperature absorber tail gas before the latter is expanded. The expansion comprises two expansion steps. Reheat of the tail gases with hot reaction gases takes place after the first expansion stage. The expansion turbines are used to drive the process compressors. Figure 2.3 shows a simple schematic of Horton's invention. At the time of Horton's invention the reaction heat of nitric acid plants was used to raise steam in boilers. In Horton's invention no steam is raised. The plant layout is therefore simplified by the omission of a waste heat boiler.

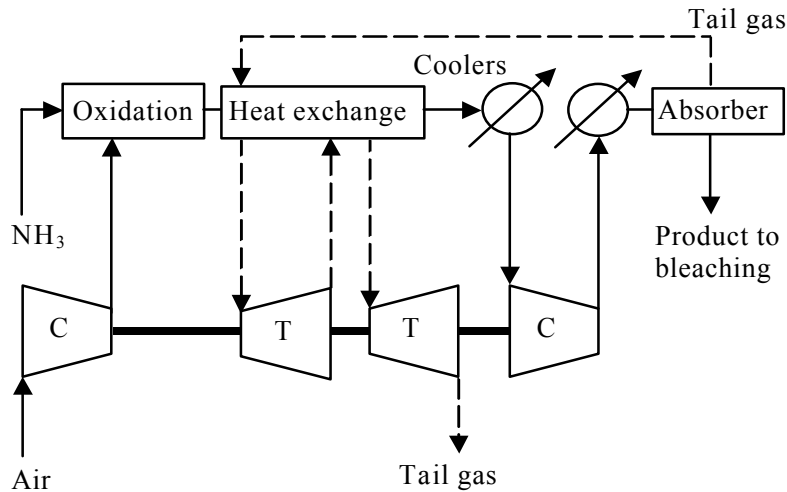

Figure 2.3 Schematic showing the invention of Horton (1969).

Linnhoff, Le Leur and Pretty (1993) patented a concept whereby the amount of work generated in exothermic, elevated pressure chemical reaction processes can be enhanced. This invention involves the use of an amount of gas in addition to that required by the process. The additional gas is compressed, bypasses the reactor and is expanded together with the reaction products (effluent or tail gas). Excess high temperature heat available from the reaction is used as a heat source for this gas. The invention takes maximum advantage of the power generation scheme and improves flexibility in meeting varying site power and heat demands. The invention is particularly applicable to air based reactions such as nitric acid production and sulphuric acid production.

Figure 2.4 shows a schematic of the basic invention, a number of variations are also possible. The dotted line shows the feed gas bypassing the process. Hot gas from the reaction process is used to heat the feed gas bypassing the reaction process (HX1), to generate steam (HX3) and to heat the process effluent gas that is expanded together with the bypassing feed gas (HX2).

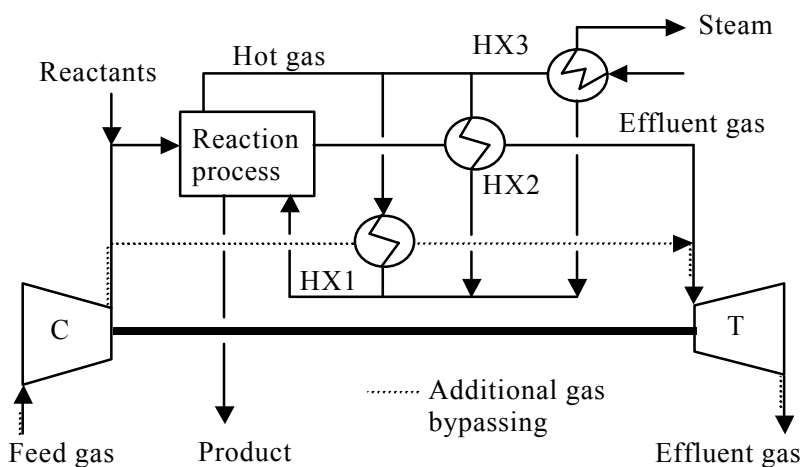

Figure 2.4 Schematic illustrating the invention of Linnhoff et al. (1993).

Another example of tail gas energy recovery is described in the patent granted to Parmegiani et al. (1971). Exhaust or tail gases (unreacted ethylene) from an ethylene oxide synthesis reactor is heated by combustion products from a boiler and then used to drive a turbine expander coupled to an air compressor. The turbine exhaust gas is delivered to the steam boiler for combustion. *Note that in this invention the tail gas is used for two purposes, namely, for expansion to drive a compressor and for further energy recovery via combustion.* Also note that combustible tail or purge gases are often used as fuel gas, either for boilers or gas turbines. Steam generated in the boiler is fed to a steam turbine that is also coupled to the turbine expander and air compressor system. The compressors deliver compressed air to the process for production of ethylene oxide. The system is shown in Figure 2.5.

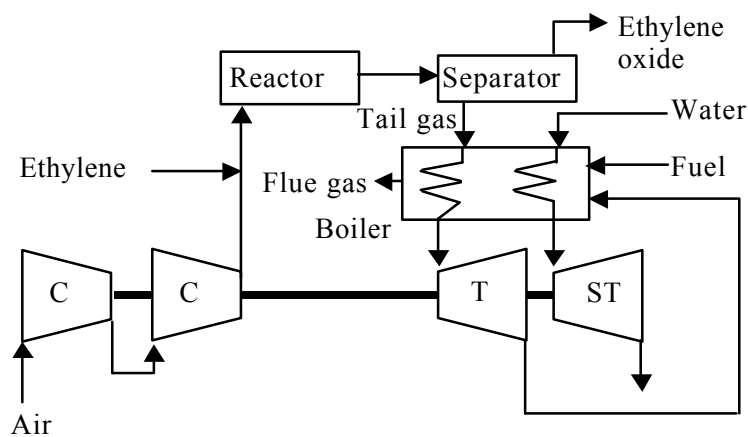

Figure 2.5 Schematic showing the invention of Parmegiani et al. (1971).

Process feed gas expansion

Reactant gas streams or feed gas may also be used as working fluid for an expansion turbine. Processes that use natural gas as a feedstock may require a lower pressure compared to the pressure at which the natural gas is available. Turbine expanders are often used in hydrocarbon processing plants to expand natural gas from as high as 200 bar (Bloch, 2001b). It may be necessary to first heat the gas before expansion to prevent a too low temperature on the outlet of the turbine expander, but it will depend on the specific conditions.

Mickalicka et al. (1960) present a system for utilisation of waste heat from exothermic reaction heat wherein a gaseous reactant of the exothermic reaction is compressed, heated by heat exchange with the hot reaction product and then expanded in a turbine expander to drive the compressor. A part of the expander exhaust is utilised as reactant in the reaction process. An example of this system is the production of sulphuric acid from pyrites, as shown in Figure 2.6. The air is heated in the heater by solid residues leaving the roasting furnace. Air discharged by the turbine is fed as reactant into the furnace.

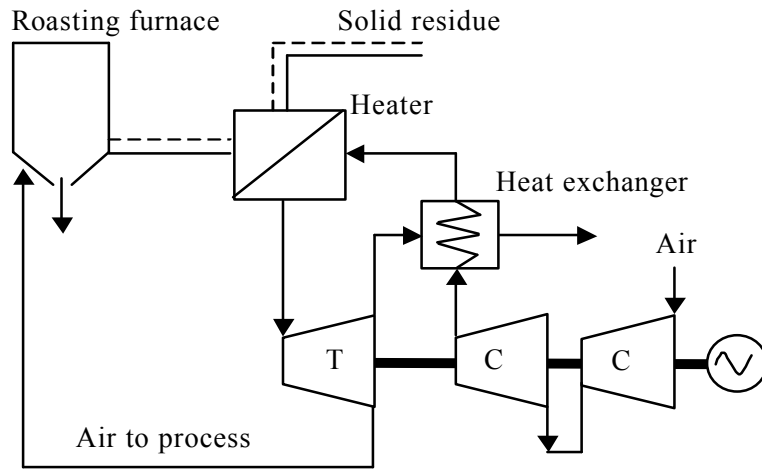

Figure 2.6 Production of sulphuric acid according to the invention by Michalicka et al. (1960).

Reactor product gas expansion

Janssen, Verkooijen and Ploumen (1997) patented a process that uses exothermic reaction heat to generate power. The exothermic reaction takes place over a catalyst in an adiabatic chemical reactor. The reaction products are expanded in a turbine that is used to drive the compressor needed to increase the pressure of the reactants. By using an adiabatic reactor the rise in internal energy due to the reaction appears as a rise in temperature of the gas mixture. *The advantage of the concept is that the thermal energy of the reactor product is converted directly to power. No heat exchange to another working fluid, such as water, is necessary. Additional thermodynamic losses associated with such heat exchange are avoided.* One example of the invention is for the production of ethene from methane, as shown in Figure 2.7. Air is compressed, mixed with methane at the same pressure and passed through a reactor over a catalyst. The preferred catalyst is lithium/magnesium oxide. After being expanded in the turbine, the gas product mixture is separated into ethene and a mixture of CO, CO₂, H₂O and CH₄. The separation device is preferably a membrane.

Barber, Muenger and Alexander (1981) patented a concept for a chemical plant combined with a semi-closed Brayton-cycle power plant. The invention is relevant for chemical processes wherein gaseous reactants undergo an exothermic reaction and the reaction product can be separated from the unconverted reactants. The invention specifically provides an ammonia synthesis process wherein the hot product gases are used to produce a portion of the power needed to drive the compressor for compressing the reactants. A simple schematic of this flow sheet is shown in Figure 2.8. An additional high temperature heat source, such as a high temperature gas, is used to heat the recycled, unconverted reactants before they are

expanded in the turbine. Regenerators (R) are employed to heat the compressor outlet with the turbine outlet and the separator outlet stream with the hot reactor product.

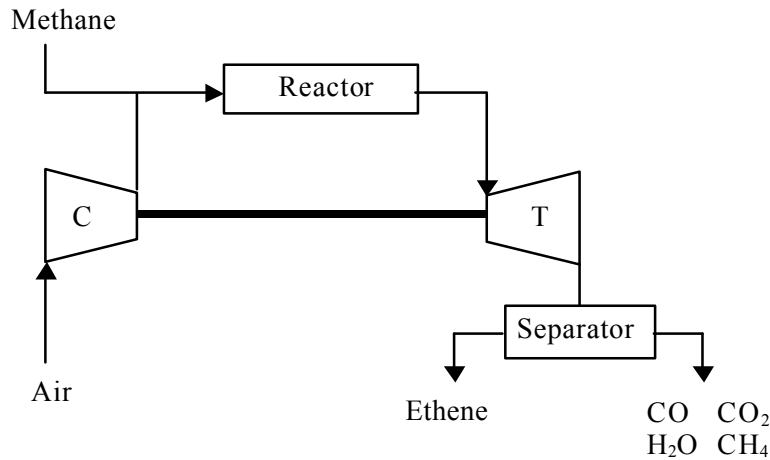

Figure 2.7 Invention of Janssen et al. (1997).

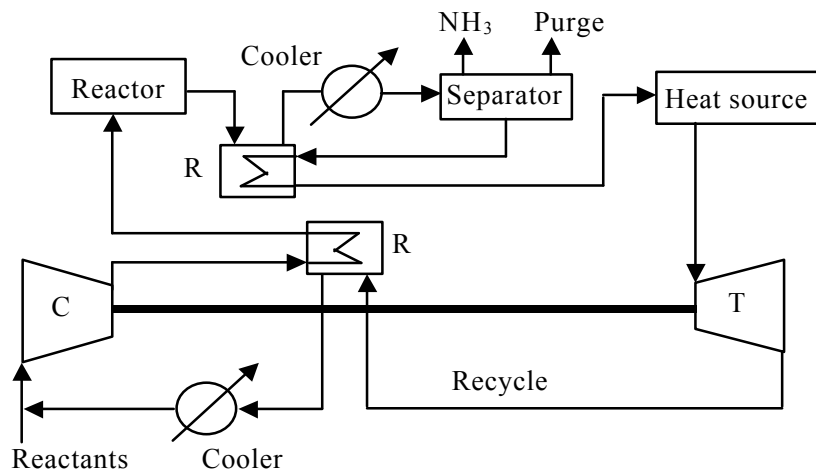

Figure 2.8 Schematic showing the invention of Barber et al. (1981).

More recently Agee et al. (2000) patented a synthesis gas production system comprising a gas turbine with an autothermal reformer (ATR) between the compressor and expander. The ATR uses a combination of partial oxidation and steam reforming. The exothermic heat of the partial oxidation step provides the heat for the endothermic steam reforming reaction. The ATR produces synthesis gas and serves as the combustor for the gas turbine. The synthesis gas may be used as a feedstock for a Fischer-Tropsch reactor, methanol or ammonia reactor. Expansion of the synthesis gas may impact on the downstream process, depending on the pressure requirements of the downstream process.

2.3 Power systems incorporating chemical unit operations

Reay (2002) discusses some interesting options for using gas turbine cycle components as chemical reactors. Useful chemical products may be produced. These options include the following:

1. The use of the combustion chamber of a gas turbine as a reforming reactor.
2. The use of a catalyst on or inside turbine blades to carry out a reaction that will cool the blades.
3. The use of intercoolers between compressor stages as heat exchanger-reactors (HEX-reactors) for endothermic reactions. Heat is removed from the compressed working fluid by allowing an endothermic reaction to take place on the reaction side of the HEX-reactor. This side of the heat exchanger may be coated with a catalyst.
4. The use of re-heaters between expansion stages as HEX-reactors for exothermic reactors.
5. The use of exhaust heat for reforming natural gas fuel, also known as chemical recuperation.

Some of these options have been realised in patents, and are discussed further.

2.3.1 Catalytic reactions in the expansion space of a gas turbine

As early as 1955 a patent was granted to Wikdahl (1955) to carry out reactions in the expansion space of a turbine device to transform the chemical energy into kinetic energy and generate electricity in a generator. The idea was to let the reaction take place between the rotor and stator blades of the turbine with a catalyst suspended in the reaction space or fixed to the walls of this space. In an example of the invention oxygen and sulphur dioxide are compressed in two separate compressors and reacted in a turbine reactor to form sulphur trioxide. The rotor and stator of the turbine are coated with platinum as catalyst. The product is passed through sulphuric acid in an absorber to remove sulphur trioxide and then is fed to another turbine with generator for expansion to atmospheric pressure. In the patent description reference is also made to other possible reactions, namely the oxidation of ammonia to nitrogen oxides, the Fischer-Tropsch process, synthesis of methanol, oxidation of methanol to formaldehyde, ethyl alcohol to acetaldehyde and acetaldehyde to acetic acid.

2.3.2 Chemically recuperated gas turbine

An idea that has made considerable progress over the past few years is the chemically recuperated gas turbine (Harvey and Kane, 1997). The idea is an extension of the steam-injected gas turbine, in which exhaust heat is used to raise steam for injection into the combustor. The concept was patented by Hines (1990) and is shown in Figure 2.9. The

exhaust heat of the gas turbine is recovered in a steam methane reformer (SMR) where an endothermic reaction takes place between the steam and methane. This is followed by a heat recovery steam generator (HRSG). The natural gas is mixed with the generated steam before being fed to the SMR. A nickel catalyst is required for the reaction that produces hydrogen, carbon dioxide and carbon monoxide. Conversion of the methane in this manner increases the heating value of the fuel. The exhaust heat is absorbed thermally as the methane and steam is heated, as well as chemically via the endothermic reaction. This leads to a larger recuperation of exhaust energy compared to heat recovery alone. *Note that although a chemical unit operation is integrated with a power system in this concept, the focus is on power generation and no chemical product is produced in addition to the power.*

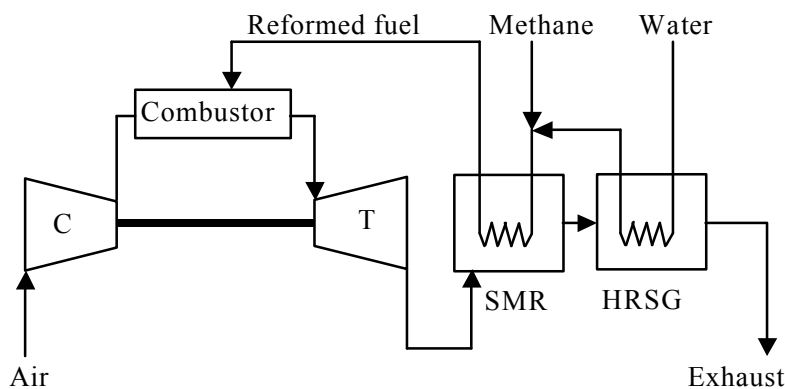

Figure 2.9 Chemically recuperated gas turbine concept (Harvey and Kane, 1997).

2.3.3 Combined cycle with partial oxidation to produce synthesis gas

An invention by Stahl (1982) caters for the combined production of power and an intermediate chemical product, namely synthesis gas. Stahl patented a combined cycle apparatus for the production of synthesis gas. In a combined cycle plant, the hot exhaust gases from the gas turbine are fed into a heat recovery steam generator to generate steam to produce electricity via a steam turbine. Combined cycle plants are very efficient but, prior to this invention by Stahl, have not been employed for producing synthesis gas or higher derivatives such as methanol. Synthesis gas, a mixture of carbon monoxide and hydrogen, can also be used for the synthesis of various other hydrocarbons.

Natural gas is partially oxidized with oxygen and steam in the combustor of a gas turbine. The reaction mixture is expanded in a gas turbine to recover part of the reaction heat as mechanical energy. The recovered energy can be used to generate electricity or be used internally for the compression work required to liquefy air.

Air cannot be used in the combustion process since nitrogen is detrimental in synthesis gas production. The nitrogen can be sold as a by-product of the process. The heat of the turbine outlet stream is recovered in a heat recovery steam generator. The steam is also expanded in a steam turbine to produce electrical energy. Figure 2.10 shows the core part of Stahl's invention.

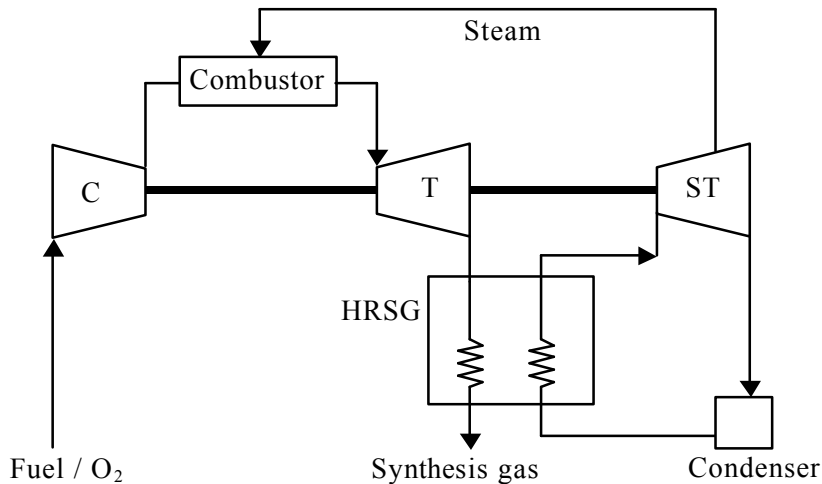

Figure 2.10 Schematic illustrating the invention of Stahl (1982).

After leaving the heat recovery steam generator, the cooled mixture of CO, H₂, CO₂ and H₂O is condensed in steps to remove the H₂O. CO₂ can also be removed via condensation to give a mixture of CO and H₂. This synthesis gas is then sent to a methanol reactor. Heat liberated through the methanol producing reaction can be used to heat steam from the steam turbine exit before the latter is recycled to the heat recovery steam generator.

The major advantage of this invention is that it is a non-polluting energy source producing chemical fuels such as methanol and/or chemical products such as synthesis gas, nitrogen and carbon dioxide. It has a high overall energy efficiency, which originates from the high degree of integration and co-operation between the gas- and steam turbines that make up the combined cycle configuration. The apparatus is relatively compact and can be installed at remote sites (oil wells and off-shore drilling stations) where natural gas is currently just flared. The gas can then be processed to methanol, which is easier to transport than methane.

2.3.4 Reactor expander topping cycle

Rao (1991) invented an improved process for converting energy contained in combustible gas streams to mechanical work. Such streams include industrial gas streams that are available under pressure and capable of reacting exothermically over a catalyst. Examples are synthesis gas from reforming processes as well as purge gas from synthesis processes such as ammonia or methanol. Instead of combusting such gases directly in a heat engine, the gas is first reacted

over a catalyst. The reaction heat is converted to work by expanding the product in a turbine expander. Only after leaving this turbine expander the gas is combusted in a heat engine. This is shown in Figure 2.11.

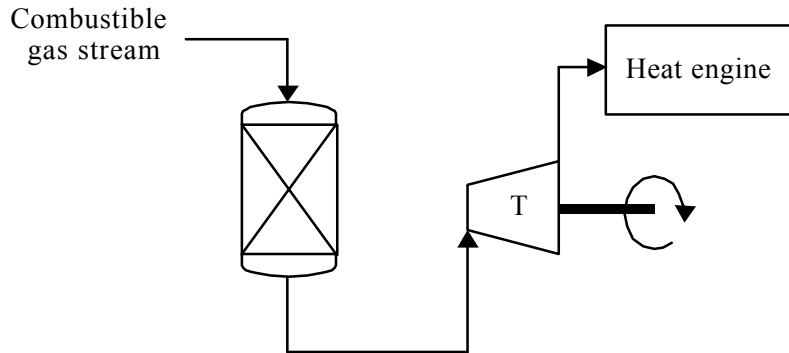

Figure 2.11 Schematic illustrating the invention of Rao (1991).

2.4 Power systems and chemical plants, integrated at the process level

Referring back to the system integration levels for trigeneration systems as defined by Dijkema et al. (1998), level 5 systems are ones in which chemical plants and power plants are combined as distinct processes to render production complexes for power, heat and chemicals. Such production complexes use many different types of feedstock to produce synthesis gas, a mixture of hydrogen and carbon monoxide. The synthesis gas is then used for power generation and the production of a variety of chemicals or liquid fuels. *The advantages are common operating facilities and economy of scale.* The concept is shown in Figure 2.12.

Applications for combined process and power plants are currently divided between *heavy fuels* and *natural gas*. Although these applications all require different process technology they all depend on power block technology developed for early IGCC plants. In the case of heavy fuels, interest in Fischer-Tropsch liquids (Integrated Gasification Fischer-Tropsch), methanol and steel mill applications is growing. For natural gas, the focus is on remote gas to liquids (GTL) and processes to reduce CO₂ emissions (Integrated Reformer Combined Cycles).

Many of the processes that can be improved by integration with gas turbines require the use of air or oxygen. Gas turbines can produce large quantities of compressed air more efficiently

than normal air compressors. Therefore air is often extracted from the gas turbine for use in fuel processing.

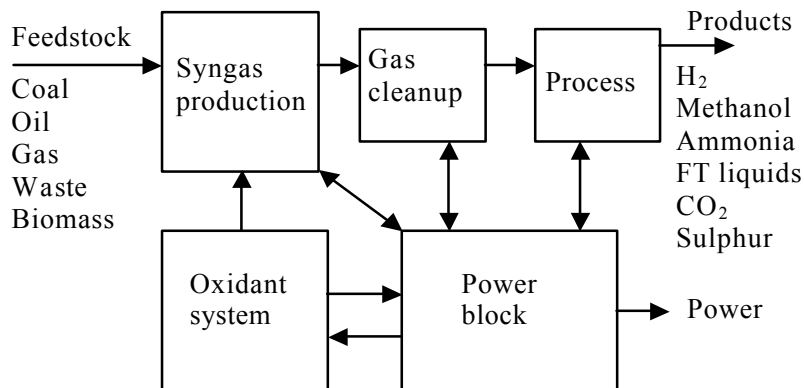

Figure 2.12 Combination of process and power plants (Todd, 1999).

Many different ideas for combined process and power plants can be found in patent literature. Most of these are also fairly recent. A patent by Kennedy (2001) is described here as an example. Kennedy (2001) patented a gas turbine with enhanced combustor integrated with a hydrocarbon conversion system, preferably a Fischer-Tropsch based unit. This concept is shown in Figure 2.13. Air is compressed in the compressor section of a gas turbine and delivered to a combustor. A portion of the air is also delivered to a chemical process that includes a synthesis gas unit in front of a Fischer-Tropsch based unit. Thermal energy is extracted from the combustor and supplied to the chemical process to convert light hydrocarbons to heavier hydrocarbons. Tail gas from the chemical process may also be directed to the combustor. A heat recovery steam generator may also be used to recover waste heat from the expanded combustion gases. The heat recovery steam generator may include a burner portion with fuel supply and a steam generation portion, as shown in Figure 2.13. Air may bypass the combustor to be fed directly to the turbine for blade cooling. This is not shown in Figure 2.13 for simplicity. The removal of heat from the combustor is accomplished by a heat recovery unit, which is not shown on the figure. Such a unit may include internal heat exchangers in the combustor and the necessary pipe work to circulate a fluid through the combustor to transport the heat to the chemical process. The combustor heat may be used to generate steam to supply to a Fischer-Tropsch conversion unit or a steam methane reformer.

The benefit of removing heat from the combustor is that greater amounts of compressed air can be extracted to the chemical plant without the turbine inlet temperature becoming too high.

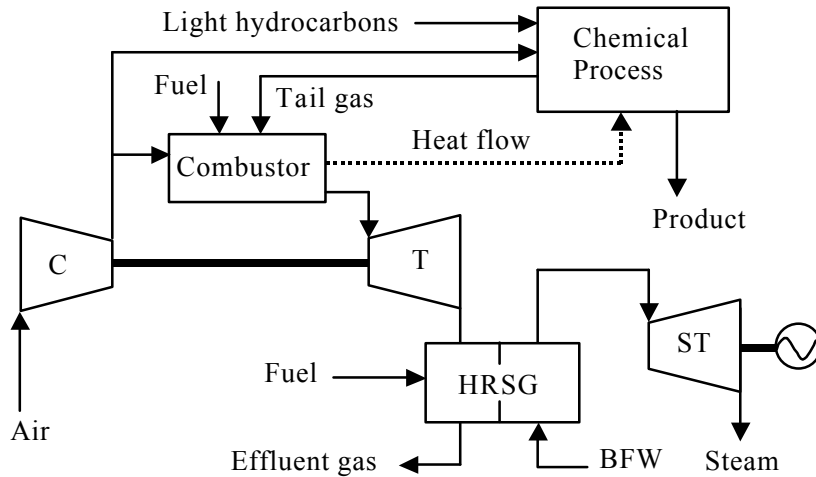

Figure 2.13 Schematic illustrating the invention of Kennedy (2001).

2.5 Conclusions

The literature review revealed that the production of power and chemicals can be combined in so many ways that it was useful to classify the various systems into categories. In the case of turbine expanders integrated with chemical processes, it was found necessary to categorise the systems further according to the type of process gas used for expansion. Whether the turbine expander is placed in flue gas, tail gas, reactor feed or product gas is significant in determining the impact of the expander on the process operation.

Only three patents could be found that deal with a turbine expander placed directly downstream of an exothermic reactor. A very recent patent was found that deals with expansion of synthesis gas from an autothermal reformer. Although synthesis gas is an intermediate product, such a system is also seen as a relevant example. The review of literature therefore shows that the integration of turbine expanders with exothermic gas-phase reactor systems is a new concept. This serves as one of the important motivations to investigate the concept and to find further applications through this work.

2.6 References

Agee MA, Weick LJ, Agee KL and Trepper EL, "Synthesis gas production system and method", *US Patent 6155039*, assigned to Syntroleum Corp (US), 2000.

Albano JV and Olszewski EF, "Gas Turbine Integration Reduces Ethylene Plant's Energy Needs", *Oil and Gas Journal*, vol. 90, no. 6, pp. 55-60, 1992.

Barber EM, Muenger JR and Alexander DL, "Combination chemical plant and Brayton-cycle power plant", *United States Patent 4273743*, assigned to Texaco Inc., USA, 1981.

Bloch HP, "Consider turbo-expanders" (Editorial Comment), *Hydrocarbon Processing*, vol. 80, no. 1, p.1, 2001a.

Bloch HP, "Become familiar with turbo-expander applications" (Reliability), *Hydrocarbon Processing*, vol. 80, no.2, pp. 17-18, 2001b.

Dijkema GPJ, Luteijn CP and Weijnen MPC, "Design of trigeneration systems", *Chemical Engineering Communications*, vol. 168, pp. 111-125, 1998.

Fink AH, "Cogeneration process linking FCC regenerator and power plant turbine", *US Patent 4338788*, assigned to UOP Inc., Des Plaines, Ill., 1982.

Goulden JE, "Recovering energy from flue gas", *US Patent 3401124*, assigned to Esso Research and Engineering Company, Delaware, 1968.

Harvey S and Kane N, "Analysis of a reheat gas turbine cycle with chemical recuperation", *Energy Conversion and Management*, vol. 38, no. 15-17, pp. 1671-1679, 1997.

Hines WR and Horner MW, "Chemically recuperated gas turbine", *US Patent 5133180*, assigned to General Electric, United States, 1992.

Horton A, "Process and Apparatus for the Manufacture of Nitric acid", *UK Patent GB1146292*, assigned to Humphreys and Glasgow Ltd., 1969.

Janssen FJJG, Verkooijen AHM and Ploumen PJ, "Synthesis of ethane", *European Patent 0753652*, The Netherlands, 1997.

Kennedy PE, "Hydrocarbon conversion system with enhanced combustor and method", *US Patent 6265453*, assigned to Syntroleum Corporation, Tulsa, OK (US), 2001.

Korobitsyn MA, "Analysis of cogeneration, combined and integrated cycles", *PhD Thesis*, University of Twente, The Netherlands, 1998.

Linnhoff B, Le Leur JE and Pretty BL, "Exothermic chemical reaction processes", *European Patent 0301844B1*, assigned to British Technology Group Ltd., GB, 1993.

Manninen J and Zhu XX, "Optimal Gas Turbine Integration to the Process Industries", *Industrial Engineering and Chemistry Research*, vol. 38, pp. 4317-4329, 1999.

Michalicka L, Drasky J and Mayer M, “A method for utilizing waste heat from exothermic chemical reactions”, *UK Patent GB 848895*, Czechoslovakia, 1960.

Parmegiani M, Milanese SD and Bellofatto O, “Process for the utilization of the exhausted gases from an ethylene oxide synthesis reactor”, *US Patent 3552122*, assigned to Snam Progetti, Milan, Italy, 1971.

Rao AD, “Reactor expander topping cycle”, *US Patent 4999993*, assigned to Fluor Corporation, United States, 1991.

Reay DA, “Gas turbine reactors – chemicals, heat and power”, *Applied Thermal Engineering*, vol. 22, pp. 569-576, 2002.

Shirato T, “Method and apparatus for recovering energy from blast furnace exhaust gas”, *US Patent US4270343*, assigned to Mitsui Shipbuilding Eng., Japan, 1981.

Terrible J, Shahani G, Gagliardi C, Baade W, Bredehoff R and Ralston M, “Consider using hydrogen to cogenerate power needs”, *Hydrocarbon Processing*, vol. 78, no. 12, 1999.

Todd D.M, “IGCC experience and technology improvements spreading to other process/power plants”, in-house presentation by GE Power Systems to Fluor Daniel, obtained from Fluor Daniel, 1999.

Wikdahl L, “Method of carrying out chemical reactions in the gaseous phase”, *UK Patent GB739483*, assigned to Wikdahl L, 1955.

Chapter 3

Flow sheet design and analysis for process gas power cycles

This chapter focuses on the design and analysis of flow sheet configurations for chemical reaction systems that use turbine expanders to recover reaction heat. The concept of using expansion turbines directly to convert exothermic reaction heat to power was introduced in Chapter 2 and is explored in more detail here. A novel approach to combine a chemical reaction system with a power cycle using an expansion turbine is then presented. This approach involves the realisation of the analogies between a chemical reaction system with expansion turbine and a power generation cycle. An important aspect of the approach is the grouping of unit operations to form appropriate and sensible systems for analysis and optimisation. A methodology for the structured development of flow sheets is then put forward. The methodology involves the consideration of various factors that impact on the flow sheet development, referred to as impact factors. These factors include e.g. single pass or recycle operation, reaction conditions, reactor operation, conditions for separation of product and the physical properties of the process gas. Once a flow sheet configuration or base case has been determined a flow sheet analysis is needed to find a suitable set of flow sheet conditions. To aid in flow sheet analysis simplified mathematical models are developed for typical process gas power cycles, namely an adiabatic reactor-separator system with equilibrium-limited reaction and one with reaction kinetics. The influence of key design variables on the power and chemicals production is illustrated using these models.

Nomenclature

Symbols

C	Integration constant
C	Concentration (kmol/m ³)
C _p	Constant pressure heat capacity (kJ/(kmol.K))
C _v	Constant volume heat capacity (kJ/(kmol.K))
E	Activation energy (kJ/kmol)
H	Enthalpy (kJ)
ΔH _R	Heat of reaction (kJ/kmol reactant)
k	Specific heat ratio (-/-)
k _r	Reaction rate constant (m ³ /kg.s)
k _{r0}	Frequency factor in Arrhenius equation (m ³ /(kg.s))
K	Equilibrium constant
m _c	Mass of catalyst (kg)

n	Flow rate (kmol/s)
P	Pressure (bar)
P _{ref}	Reference pressure (bar)
Q	Heat (kW)
Q _{COOL}	Heat removed for cooling (kW)
Q _{PG}	Heat transferred to the process gas working fluid (kW)
Q _R	Reaction heat (kW)
Q _{IN}	Heat input to a power cycle (kW)
Q _{OUT}	Heat removed from a power cycle (kW)
r	Reaction rate (kmol/s)
R	Ideal gas constant (= 8.314 kJ/(kmol.K))
S	Entropy (kJ/(kmol.K))
T	Temperature (°C or K)
W _{NET}	Net work produced by or required by a system (kW)
W _T	Total work produced by expanders (kW)
W _C	Total work required by compressors (kW)
W _{SEP}	Work required for separation (kW)
x	Conversion (-/-)
y	Mole fraction (-/-)

Subscripts

A	Chemical component A
B	Chemical component B
C	Cold
F	Feed
H	Hot
P	Product
R	Recycle
UF	Utility fluid
PG	Process gas

Greek Symbols

η	Power cycle efficiency
ν	Stoichiometric coefficient

Flow sheet abbreviations

C	Compressor
T	Turbine expander

3.1 Introduction to the concept of direct conversion of reaction heat to power

In conventional process systems the reaction heat of exothermic reactions is typically transferred by heat exchange to a utility fluid for use at a different location. Steam raising systems are commonly used. The steam may be exported to another process plant, used for process heating or be used to generate power in steam turbines, either for export or process requirements. *A system is defined here as a number of unit operations that are grouped and operated together to achieve a common purpose.*

The concept for direct conversion of reaction heat to power is looked at in more detail next by means of a simple example of a system comprising an adiabatic exothermic reactor. See Figure 3.1. A high-pressure gas-phase chemical reaction takes place in the reactor. Since the reactor is adiabatic the rise in enthalpy of the reacting mixture appears as a rise in temperature over the reactor. The reaction product (1) is passed in a heat exchange relationship with a pressurised utility fluid (3) to recover the reaction heat. The heated utility fluid (4) is used to generate power by expanding it in a utility turbine. The purpose of the system is therefore to recover reaction heat to generate power and also to produce a chemical product. The working fluid of the energy system and the process fluid are separated. In cooled chemical reactors the heat exchanger is integrated with the reactor, however, the intermediate utility fluid is still used.

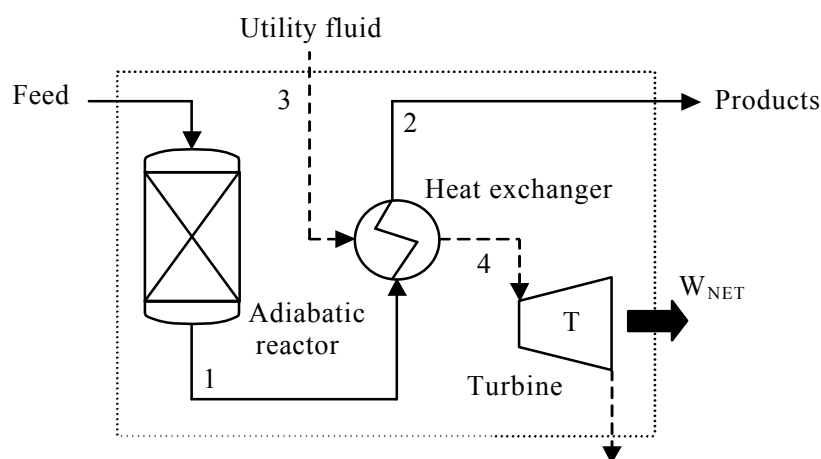

Figure 3.1 Exothermic adiabatic reactor with product heat exchanger and utility turbine.

Power generation using exothermic reaction heat can also be achieved by direct expansion of the hot, high-pressure product gas in a turbine expander, as shown in Figure 3.2. The advantage of this concept is that no heat exchange to another working fluid is necessary. Additional thermodynamic losses associated with such heat exchange are avoided. The process fluid that is expanded is at a higher temperature compared to the utility fluid in the conventional system in Figure 3.1. Due to the required temperature driving force for heat

exchange the utility fluid will always be at a lower temperature compared to the reactor product gas.

The main difference between the two systems is in the level of process integration. The integration of chemical processes and energy conversion devices in chemical plants can take place at various levels, as demonstrated by Dijkema et al., who have considered five possible integration levels (Dijkema et al., 1998). These levels were also discussed in Chapter 2, section 2.1. The system-integration level corresponds to level 4 of Dijkema et al., that is the integration of an energy conversion device and a chemical unit operation. The indirect system, as shown in Figure 3.1, includes five process elements, namely the chemical reactor, heat exchanger, turbine, chemical products and utility streams, whereas the direct system shown in Figure 3.2 only includes three process elements, namely the chemical reactor, turbine, and chemical products stream.

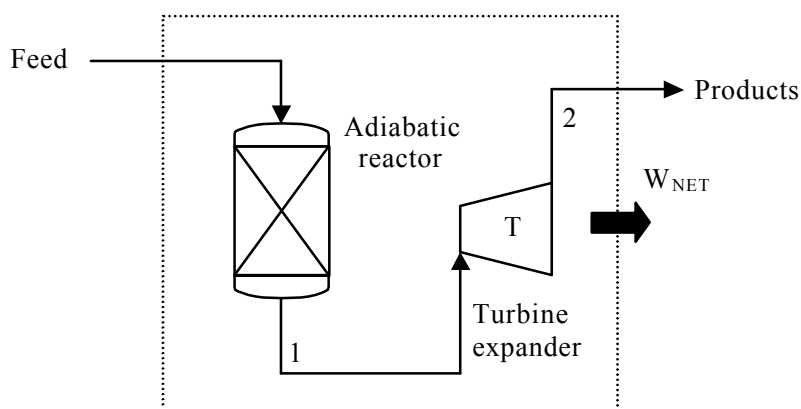

Figure 3.2 Exothermic adiabatic reactor with product turbine expander.

In Table 3.1 the qualitative characteristics of the two reaction-heat recovery schemes are listed. *Comparison of the two systems in this example is problematic since the thermodynamic state of the product is not the same.* Note that the choice of system boundaries is particularly important. The product (stream 2) is not at the same pressure in the two systems and may also not be at the same temperature. The product temperature in the system integrated with a turbine expander will depend on the pressure ratio achieved over the expander. The conditions required for downstream processing of the product should also be considered and may dictate the outlet conditions of the turbine expander. In the case of a retrofit situation this is particularly important since one will be limited by design conditions associated with existing process equipment. *Factors such as these will influence the structure of a combined chemicals and power production flow sheet and are considered later in this chapter as part of a methodology to develop such flow sheets. The issue of system boundaries is also considered further in the next section as one of the key elements in an approach to combine a chemical reaction system with a power cycle.*

Table 3.1 Qualitative comparison of reaction heat recovery systems (see Figures 3.1 and 3.2)

Product turbine expander	Product heat exchanger and utility turbine
1 Heat for power generation is available at the maximum temperature of the system at the reactor outlet, T_1 .	Heat for power generation is available at the utility fluid temperature, T_4 . $T_4 = T_1 - \Delta T$ where ΔT is the temperature difference on the hot side of the heat exchanger.
2 Process fluid is used as a working fluid.	Utility fluid is used as a working fluid.
3 Pressure of the products, P_2 , is considerably lower than P_1 due to the expansion.	Pressure of the products, P_2 , is similar to P_1 .
4 One process unit, namely the turbine expander, is needed to convert the reaction heat to power.	Two process units, namely the heat exchanger and utility turbine are needed to convert the reaction heat to power.
5 This system can utilise the pressure and thermal exergy of stream 1 to produce power.	Only the thermal exergy of stream 1 can be used to produce power.

3.2 Combining a chemical reaction system and a power cycle

3.2.1 Basis for a flow sheet design methodology – a novel approach

In Chapter 2 it was revealed that turbine expanders that are integrated into chemical processes are mostly placed in tail gas, flue gas or purge gas streams. These gas streams are often not processed further in downstream unit operations and also do not contain the main chemical product of the process. Few examples exist of expansion turbines used for direct expansion of reactor product gas to recover reaction heat. Expansion of reactor product gas will have a much greater impact on process operations, optimum process conditions or even the process configuration compared to expansion of tail, flue or purge gas streams. The process gas used as a working fluid will often be in an intermediate stage of processing and will contain the main chemical product of the process. Evidently a unique design methodology is needed to lend structure to the development and analysis of flow sheet configurations for chemical reaction systems that use turbine expanders to recover reaction heat.

The basis for this structured flow sheet design methodology, presented later in this chapter, is a novel approach to combine a chemical reaction system and power production system. This novel approach involves the following three aspects:

Realisation of analogies

The analogy between a chemical reaction system with expansion turbine and a conventional power generation cycle is realised. Chemical reaction-power production cycle flow sheets are structured analogous to power production cycles. A power cycle includes a number of crucial processing steps necessary to render a net power output. *As a minimum requirement the process working fluid should undergo the same processing steps as the working fluid of a conventional power cycle to make power production possible.* The system should, however, still be able to produce the chemical product.

Utilisation of synergistic effects

Synergistic effects are identified and used to improve the flow sheet. These are instances where a unit operation is needed in the production of the chemical as well as production of power. On combining the power and chemical production, the unit operation is shared. Synergistic effects are best explained using an example. A generic example is presented in section 3.2.4 and a real example can be found in the methanol case study in section 5.2 of this thesis.

Definition of appropriate system boundaries

Systems instead of single unit operations are considered. Unit operations are grouped to form appropriate and sensible systems for comparison, analysis and optimisation. *In this regard two approaches can be followed to define system boundaries for comparison of systems:*

- Only the section of the flow sheet where differences exist between two processes can be enclosed by a system boundary. The process streams entering and leaving the system boundaries should then be at the same thermodynamic state, i.e. upstream and downstream unit operations are not affected by a change in state. This option is useful in retrofit situations where most of the existing process unit operations need to be maintained at the original design conditions. An example of this approach is found in the phthalic anhydride case study presented in Chapter 4. Refer to section 4.4 and Figure 4.4 where the system boundaries for executing an exergy analysis are shown. This case study is a good example of a retrofit situation since only a section of the flow sheet is changed without affecting the downstream unit operations.
- In another approach the comparison of systems is done using the concept of *heat engines*. All unit operations needed to complete a power cycle are included within the system boundaries. Refer to Figure 3.16 where the concept of a process gas power cycle versus a utility fluid power cycle is illustrated by using heat engines. In the case studies on methanol, ammonia and ethylene oxide (Chapters 5, 6 and 7) this approach

is illustrated. In all these cases processes integrated with turbine expanders are compared to conventional processes. The system boundaries have been carefully chosen and the heat and work flow for the purposes of heat engine representation are calculated.

Apart from the aspects described here, a power cycle should be combined with a chemical process in such a way that the requirements of both the power cycle and the chemical process are satisfied. The basic principles of chemical reaction systems and power generation cycles are therefore briefly discussed next before the approach to combine these systems is illustrated in section 3.2.4 by means of a generic example.

3.2.2 Chemical reaction systems

Many chemical process systems consist of a reactor and a separation unit. These unit operations are considered to be the core of a chemical process. Energy supply to and withdrawal from the process are labelled as utilities in traditional process design (Dijkema et al., 1998). The utilities include the steam system, process furnaces, electricity generation and supply on the site, the fuel supply system for fired heaters and furnaces, process water and water treatment etc.

Production of chemicals in exothermic, elevated pressure gas-phase reactors requires compression of the reactants. The reaction heat needs to be removed, either in the reactor unit or from the hot product, or by some combination. This will depend on whether the reactor operation is *adiabatic* or *isothermal*. The reaction product is processed further to achieve the required product quality.

Reactors may also be operated somewhere between the isothermal and adiabatic mode. A portion of the reaction heat is then absorbed by the process gas; with a subsequent temperature rise over the reactor. The remaining reaction heat is removed by a heat extraction system. This is often necessary to prevent hot spots and runaway conditions.

Many different chemical reaction systems that combine various kinds of unit operations are possible. A few examples will be described here. Figure 3.3 shows a simple diagram of a once-through adiabatic reactor system wherein cooling of the product takes place before further processing. The reaction heat is cooled away using a utility fluid. A once-through isothermal reactor system is of course also possible. Cooling will then take place by means of coils installed within the reactor shell.

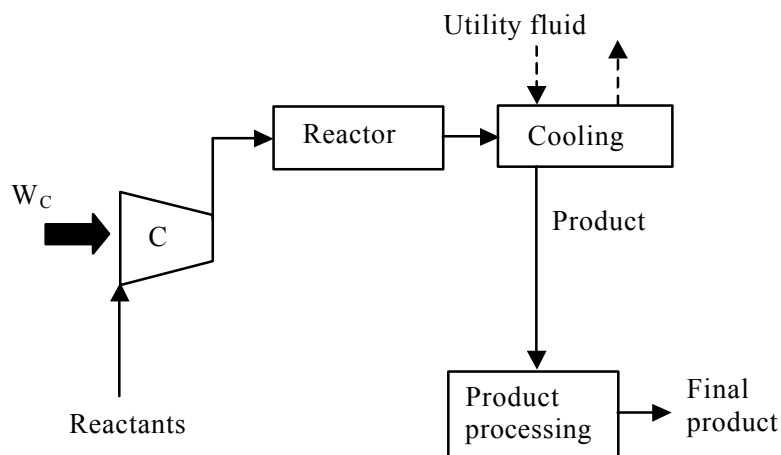

Figure 3.3 Adiabatic reactor system with high conversion and no recycle.

Due to kinetic limitations exothermic reactions are usually carried out at a high temperature where the conversion is limited by chemical equilibrium. In these reactor systems it is necessary to recycle the reactants. The product needs to be separated from the recycle stream within the recycle loop. A reactor-separator system with recycle is also referred to as a *chemicals synthesis loop*.

Figure 3.4 shows a system with recycle where cooling of the reactor takes place within the reactor unit, i.e. the reactor is operated isothermally. A purge stream is needed to prevent a high concentration of inert gases accumulating in the recycle loop. Build-up of inert gases may affect the reaction negatively. The purge take-off should be positioned between the separator and the reactor to prevent unnecessary loss of product. Further product processing is not shown here. Note that work is needed to separate the product from the recycle loop. Cold separation is commonly done and the work needed is then the work required for refrigeration. In addition to compressing the reactants, the recycle also needs to be recompressed due to pressure losses in the synthesis loop. A separate compressor may be used for the recycle or in some cases the recycle is fed into a second or third stage of the existing feed compressor, as shown in the Figure 3.4.

An additional separation step may be included in recycle streams to remove unwanted byproduct gases that may have a negative effect on the reaction or take up unnecessary space in the loop. In some reactor systems reactants may be in liquid form and are brought to the required reactor pressure using a pump. The pressurised liquid reactant may first be vapourised by heating it before entering the reactor or it may be injected directly into the reactor where it is vapourised by the reaction heat. Heat integration in reaction systems are often done via heat exchange between the hot reaction product and reactant feeds.

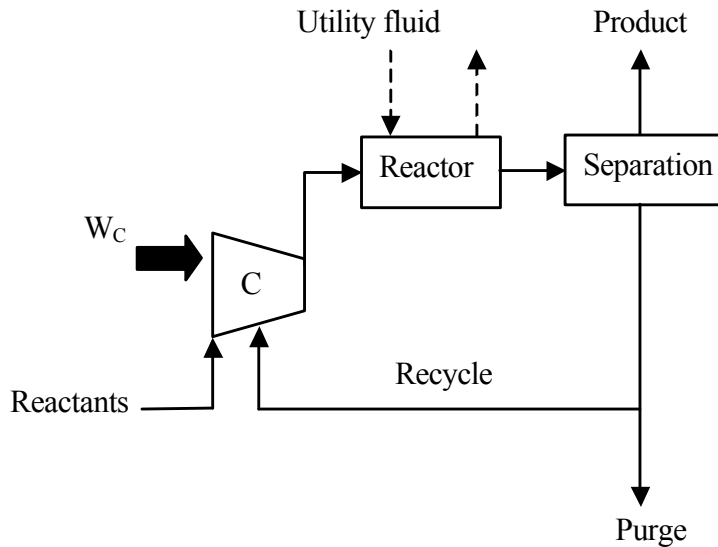

Figure 3.4 Isothermal reactor system with low conversion requiring a recycle.

3.2.3 Power generation systems

Two types of power generation systems are relevant to the integration of power plants and chemical processes, namely *vapour power plants* and *gas turbine power plants*. In vapour power plants the working fluid is alternately vaporised and condensed whereas in gas turbine power plants the working fluid remains a gas. Vapour power cycles mostly use water as a working fluid and are relevant to processes where reactors or reactor products are cooled via raising steam and the steam is used to drive process compressors or to generate power. The gas turbine cycles are more relevant to the actual integration of the turbine expander with a reactor system since process gas becomes the working fluid to create a gas power cycle. However, some combination of gas and vapour power cycle may also be obtained when creating a power cycle that uses a process fluid.

Power plants use power cycles that can also be modelled as *heat engines*. A heat engine produces work while operating between a hot temperature (T_H) and cold temperature (T_C) reservoir. The maximum thermal efficiency that any power cycle can obtain is when it is operated in the Carnot cycle (see Figure 3.5). The thermal efficiency is defined as the fraction of heat supplied from the hot reservoir that is converted to work. In the case of the ideal Carnot cycle the thermal efficiency is referred to as the Carnot efficiency:

$$\mathbf{h}_{CARNOT} = \frac{W}{Q_H} = 1 - \frac{T_C}{T_H} \quad \dots 3.1$$

Vapour power plants

The majority of power generation plants are vapour power plants, using water as working fluid and following the Rankine cycle, 1-2-3-4, as shown in Figure 3.5. The Rankine cycle was devised due to practical difficulties in compressing wet vapour in the Carnot cycle. The working fluid is condensed completely and then compressed using a pump. The work required to compress a liquid is much less than the work to compress a vapour. The ratio of compression work to expansion work is known as the *back work ratio*. For vapour power plants back work ratios are normally only 1-2%.

The components of a basic vapour power plant are shown in Figure 3.6. The dotted lines show the boundary for representing the cycle as a *heat engine* with Q_H the heat input from the high temperature reservoir and Q_C the heat dumped to the cold reservoir.

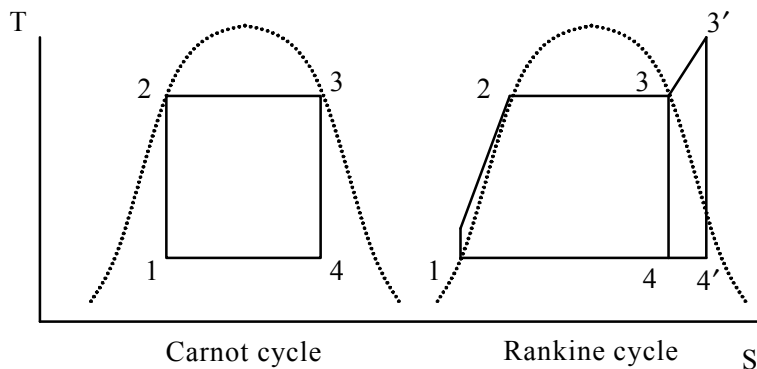

Figure 3.5 Carnot and Rankine cycles.

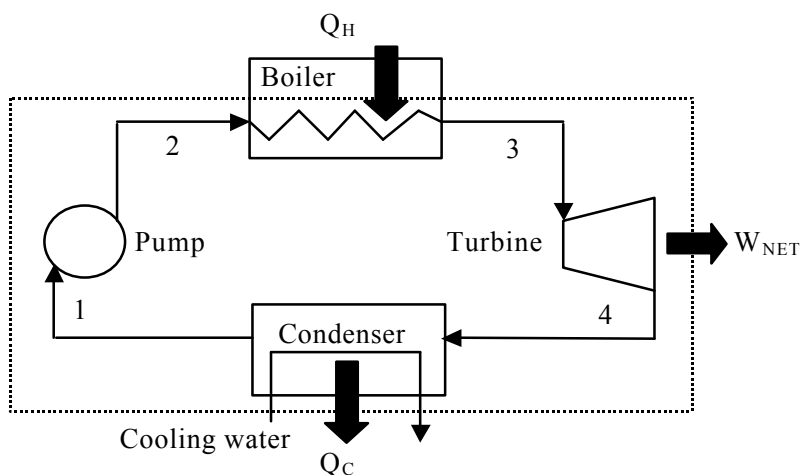

Figure 3.6 Components of a vapour power cycle.

Various modifications are incorporated into vapour power cycles to improve performance. Superheat and reheat are common features of vapour power plants. The cycle with superheat,

1-2-3'-4' in Figure 3.5, has a higher average temperature of heat addition compared to the simple cycle. The problem of low steam quality at the turbine exhaust is also addressed. With reheat the steam expands in two stages and is reheated after the first stage. Efficiency is increased whilst low-quality steam at the turbine outlet is avoided.

A major disadvantage of fossil-fueled vapour power plants is the great irreversibility associated with the combustion of fuel and the heat transfer from the hot combustion products to the working fluid.

Gas power plants

Gas power cycles follow the Brayton power cycle, also known as the Joule cycle. In such a cycle the working fluid undergoes isentropic compression to the maximum working pressure, heat addition at constant pressure, isentropic expansion to the initial pressure and heat release at constant pressure. The ideal Brayton cycle is shown in Figure 3.7. The Brayton cycle can be realised as a *closed system*, utilising heat transfer processes (Figure 3.8), or as an *open system* utilising an internal-combustion process (Figure 3.9).

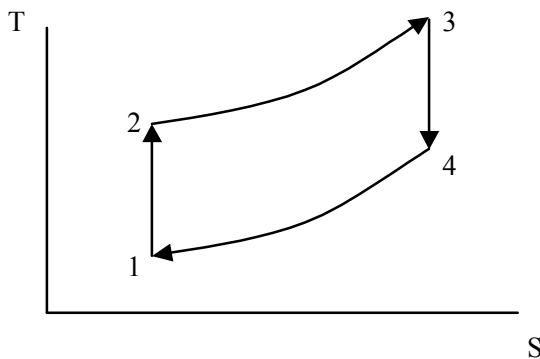

Figure 3.7 Ideal Brayton cycle.

In the open cycle gas turbine plant the heat transfer area for heating is eliminated by burning fuel directly in the working fluid (combustion). The waste heat is rejected into the atmosphere, eliminating the need for separate cooling. These factors make a gas turbine plant compact and cost-effective compared to a vapour power plant. Back work ratios of gas turbine plants are however much higher compared to vapour power plants and are typically between 40 and 80%.

Gas turbine systems are often studied using the air-standard analysis. In this analysis it is assumed that the working fluid is air, which behaves as an ideal gas. Secondly it is assumed that the temperature rise due to combustion is accomplished by heat transferred from an

external source. Although the air-standard analysis simplifies the study of gas turbine plants, it may provide useful qualitative indications of plant performance.

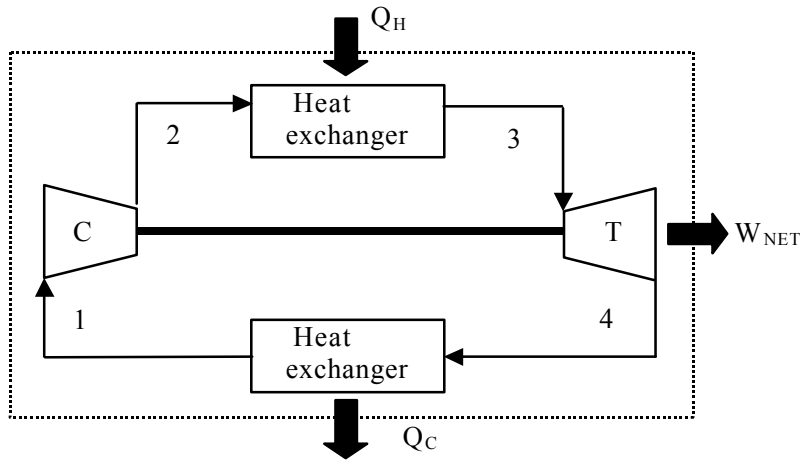

Figure 3.8 Components of a closed Brayton cycle power plant.

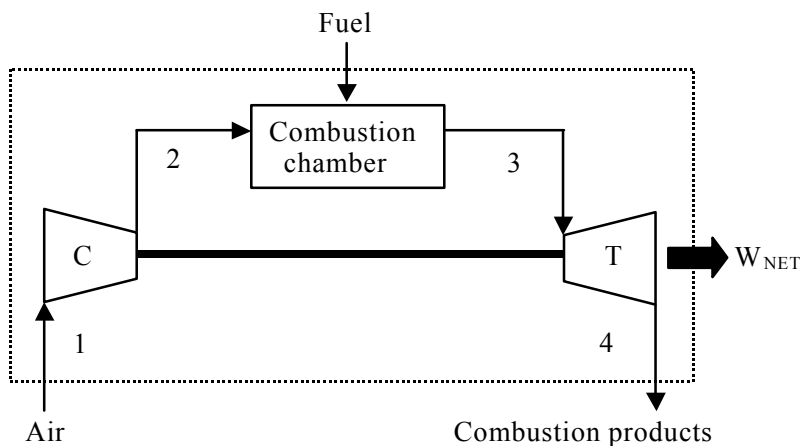

Figure 3.9 Components of an open Brayton cycle power plant.

In the ideal Brayton cycle irreversibilities due to frictional pressure loss and stray heat transfer to the environment are ignored. For an ideal air-standard Brayton cycle with constant heat capacity (C_p), the thermal efficiency is a function of pressure ratio and specific heat ratio:

$$\eta = 1 - \left(\frac{P_{out}}{P_{in}} \right)^{\frac{1-k}{k}} \quad \dots 3.2$$

The work of compression or expansion depends on the pressure ratio as well as the inlet temperature of the compressor or turbine:

$$W = \frac{nkRT_{in}}{k-1} \left[\left(\frac{P_{out}}{P_{in}} \right)^{\frac{k-1}{k}} - 1 \right] \quad \dots 3.3$$

The requirements for power production using a Brayton cycle therefore are:

- A relatively high pressure ratio over the compressor in order to obtain a reasonable cycle efficiency.
- A low compressor inlet temperature and a high turbine inlet temperature to ensure that the net work developed is sufficient.
- Minimisation of the amount of gas to be compressed and maximisation of the amount of gas to be expanded.
- A source of heat is needed in order to drive the cycle.

Improvements to the gas turbine cycle include regeneration, reheat and intercooling. In regeneration the hot turbine exhaust gas is used to preheat the air exiting the compressor before it enters the combustor. This leads to a reduction in the fuel consumption. Reheat between turbine expansion stages and intercooling between compression stages will increase the net amount of work obtained from the cycle whereas by combination of reheat and intercooling with regeneration significant increases in thermal efficiency may be obtained.

Working fluids

The majority of vapour power plants use water as working fluid. Water is plentiful, low in cost, non-toxic, chemically stable and relatively non-corrosive. However, the critical temperature of water is only 371.14 °C, which is about 225 °C below the maximum allowable steam turbine inlet temperatures. To achieve a high average temperature of heat addition and corresponding higher thermal efficiency, it is necessary to operate the steam generator at supercritical pressures. Expensive piping and heat exchanger tubes will be required. Another negative characteristic of water is that its saturation pressure at normal condenser temperatures is well below atmospheric pressure and air can therefore leak into the system. Special equipment is needed to remove the air.

Alternative working fluids to water are employed in special cases e.g. ammonia for low temperature cycles and mercury for spaceflight applications where cycles operate at relatively high temperatures.

As mentioned previously, air-standard analysis is often used to analyse gas turbine cycles. It is assumed that the working fluid is air and it behaves as an ideal gas.

Process gas may behave fairly different to air and water when used as a working fluid. The process gas will most probably be a mixture of gases and may contain water or other substances that may form a condensate under certain conditions. The properties of the gas will also change through the cycle as a reaction takes place that changes the composition. Whether or not the ideal gas assumption can be made will depend on the pressure and what type of gas it is. Special attention will have to be paid to the process gas properties as well as possible safety hazards.

Combined cycles

Combined cycles use two working fluids namely one with good high temperature characteristics and another with good characteristics at a lower temperature end of operation. The high temperature cycle (topping cycle) rejects heat into the low temperature cycle (bottoming cycle) via an interconnecting heat exchanger. Higher thermal efficiencies are obtained in this manner. The combination of gas turbine cycles and vapour power cycles is well known and has been implemented. In such plants the high temperature turbine exhaust of the gas power plant is used to raise steam in a steam generator for the vapour power cycle. It would certainly also be possible to have a process gas power cycle that rejects heat into a vapour power cycle to obtain a combined cycle. The temperature levels in the process gas power cycle will however determine whether such a combination can be achieved.

3.2.4 A generic example of combining a chemical reaction system and a power cycle

A generic example is presented here to illustrate the novel approach to combine a chemical reaction system with a power cycle. In this example an adiabatic reaction system with recycle and separation, shown in Figure 3.10, is used. It is assumed that cold separation is used to separate the product from the recycle gas stream. Work will be required for refrigeration (W_{SEP}) if the cold separation is to take place at temperatures below that of the environment.

The reaction system is combined with a Brayton cycle by superimposing the Brayton cycle onto the reactor-separator system in Figure 3.10. The combined system shown in Figure 3.11 is obtained. The turbine is placed directly after the reactor utilising the high temperature of the process gas.

The approach to combining the systems are illustrated according to its three main aspects, as applied to this example:

- *Analogous power production cycle structure*

The system in Figure 3.11 is deliberately drawn to remind of the diagrams of Brayton cycles in Figures 3.8 and 3.9 above, using the same stream numbers. The structure of the combined flow sheet is analogous to that of the Brayton power cycle. The process gas, which is now also a working fluid, undergoes the four processing steps required for a Brayton power cycle. These are compression (1-2), heat addition (2-3), expansion (3-4) and heat release (4-1). The system is however still able to produce the chemical product. The chemical reactor replaces the combustion step in the Brayton cycle. The system is also a combination of an open and closed gas turbine cycle; it is partially open due to reactants flowing in and product and purge streams leaving the system. Heat integration between streams 4 and 2 may be implemented to

further improve the system. This will be similar to the concept of regeneration employed in conventional gas turbine cycles.

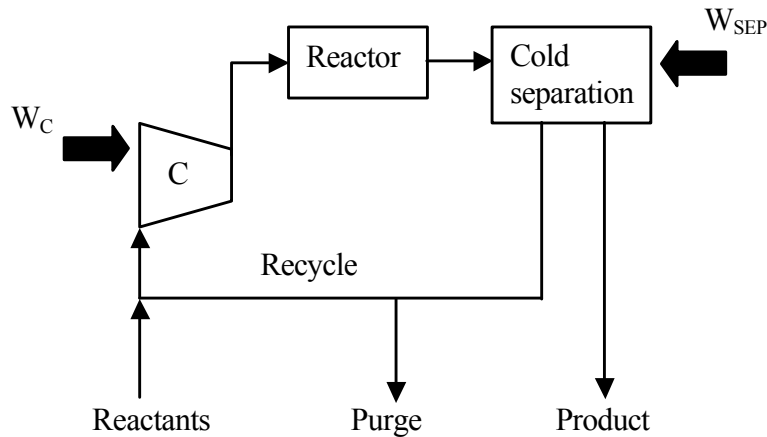

Figure 3.10 Adiabatic reaction system with recycle and cold separation.

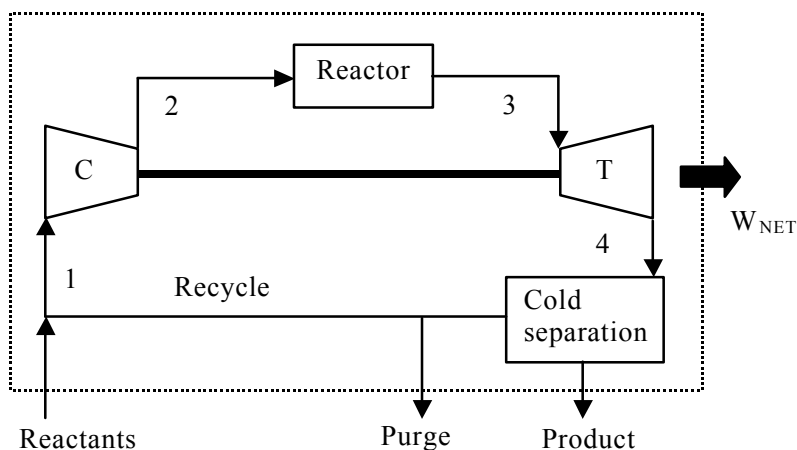

Figure 3.11 Combined reaction system and Brayton power cycle.

- *Utilisation of synergistic effects*

Due to the placement of the turbine expander in the reactor outlet, the separator sees the lower pressure in system. This may be feasible depending on the requirements for the separation operation. At a lower pressure a lower temperature may be needed to obtain the same degree of separation as in the original reaction system. However, the cooling on the low pressure side of the system is a requirement for the separation as well as for the power production and is therefore a synergistic effect. In terms of the power cycle waste heat is rejected through the required cooling on the low pressure side. Heat release is also effected by the enthalpy difference between the material streams flowing

across the system boundaries. Compression is also a requirement of both the power cycle and reaction system and is therefore another synergistic effect.

- *Appropriate system boundaries*

A system boundary for the combined system is shown using dotted lines in Figure 3.11. It makes the most sense to include all of the processing steps that the process gas undergoes to complete a power cycle within this system boundary. Simple power cycle model equations may then be used to assess the power production potential of the combined system. In the current example it makes sense to include the separation operation in the system due to its role in heat release as required by the power cycle. In a once-through system without recycle it may not be necessary to include downstream product processing in the system boundaries. Whether to include a unit operation or not will depend on the contribution of that unit operation to the objectives of the combined system.

3.2.5 Thermodynamics, chemistry and physics relevant to a reactor coupled to a turbine expander

The only chemistry relevant to the expansion of reaction product gas is the chemical reactions taking place in the reactor. The type and extent of the reactions will obviously influence the state and composition of the product gas leaving the reactor. The conversion and heat of reaction is also important since this will determine the amount of high temperature heat that is made available to produce power in the process gas power cycle.

Once the product gas leaves the reactor only physicochemical processes are of relevance, no further chemical reactions will take place. Physicochemical processes include widely used operations such as compression, expansion, liquefaction, distillation and refrigeration. As discussed in section 3.2.3, compression and expansion are key unit operations in a thermodynamic cycle to produce power. Liquefaction, refrigeration and distillation are important operations in reaction systems where products are separated from recycle streams or where products are purified in downstream process units.

There are two major reasons why gases are expanded: to obtain work or to lower the temperature for processes such as liquefaction and refrigeration. An extreme example of gas expansion is the adiabatic throttling process which normally lowers the gas temperature, but produces no work. The energy balance for this process is $\Delta H = 0$ and therefore the process is also known as an isenthalpic expansion.

To produce work from a reversible gas expansion either an isothermal or an adiabatic path may be followed. In both cases the pressure and temperature is lowered while work is also performed. An isothermal path will produce the most work and this path can be approached by using multistage expansion with adiabatically operated stages and reheating between the

stages. Similarly, for compression, a reversible isothermal path will require the least amount of work.

The efficiency that is frequently used to describe how real expansion and compression processes deviate from the reversible paths is the isentropic efficiency. Comparison of real and isentropic expansion is shown in Figure 3.12. For a real expansion a higher temperature will be obtained on the expander outlet compared to that of the isentropic case.

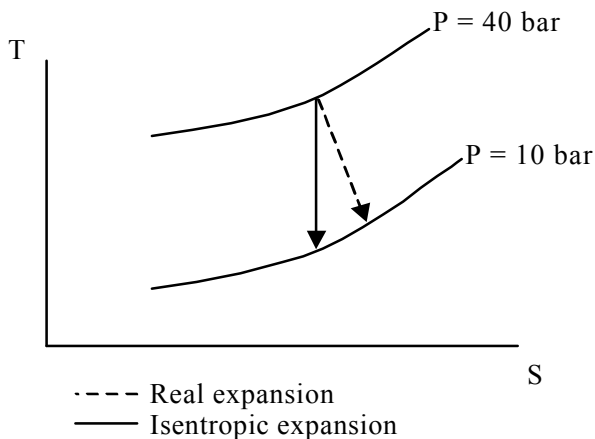

Figure 3.12 Comparison of real and isentropic expansion.

The state of the product gas leaving the reactor determines the amount of work that may be obtained from the expander; the work is proportional to the temperature of the product gas and the pressure ratio (refer to equation 3.3 which is valid for isentropic process).

The conditions at the outlet of the expander are determined by the isentropic efficiency, inlet temperature and pressure ratio as well as the properties of the gas that undergoes the expansion. The temperature and pressure at the outlet may be such that condensation of the gas or some of the components in the gas occurs. Most likely only water and heavier hydrocarbon gases will tend to condense, many of the gases used in gas-phase chemical reactions have critical temperatures far below that of water and will therefore remain in the gas phase. Examples of such gases and their critical temperatures are given in Table 3.2. Condensation is not desirable in conventional expanders since it causes erosion. There will be limits on the amount of condensate that can be handled. For example, in the case of steam turbines, there is typically a limit of 10% on the condensate content in the outlet.

Other properties of the gas that will change upon expansion are the density and viscosity. These properties play a role in the area of thermofluid mechanics which deals with the detailed design of mechanical devices such as expanders and compressors. The design of these machines is based on propulsion principles. These principles include the first law of thermodynamics, Newton's second and third laws and the continuity equation for steady flow.

Density and viscosity are also important in hydraulics, mainly for friction pressure drop calculations and detailed equipment rating and piping systems design.

Table 3.2 Critical temperatures of process gases (Atkins, 1990).

Gas	Critical temperature K
H ₂ O	647.4
NH ₃	405.5
C ₂ H ₆	305.4
C ₂ H ₄	283.1
CH ₄	190.6
N ₂	126.3
O ₂	154.8
H ₂	33.23

3.3 Methodology for developing and analysing the flow sheets of integrated systems

3.3.1 Methodology overview

The methodology comprises the consideration of a number of factors that are typical process characteristics influencing the structure of the combined chemicals and power production flow sheets. These process characteristics are referred to as *impact factors*. Two kinds of impact factors were identified, namely *general impact factors*, or those that are relevant in all the processes, and *specific impact factors* or those that are very specific characteristics of one single process.

In the methodology the information about the chemical reaction process to be combined with a turbine expander is organised by listing the general impact factors and assigning relevant process information to each factor. Important requirements of the chemical process, which can not be assigned to any of the general factors, are listed separately as specific impact factors.

The chemical reaction system is then combined with the power cycle following the approach described in previously. Once a flow sheet configuration or base case has been determined a *flow sheet analysis* is needed to find a suitable set of flow sheet conditions. Many *flow sheet parameters* may influence the power and chemicals production within the flow sheet; such parameters should be identified and varied within acceptable limits during flow sheet analysis. The analysis of flow sheets is illustrated in the various case studies presented in Chapters 4 to 8. The methodology is summarised in Figure 3.13.

The development of the integrated flow sheet requires an understanding of the role of the factors impacting on this development. It would be impossible to automate any kind of flow sheet design. However, guidelines can be provided and a structured method can be suggested to assist the developer. The impact factors and their roles in the flow sheet design are discussed in the next section.

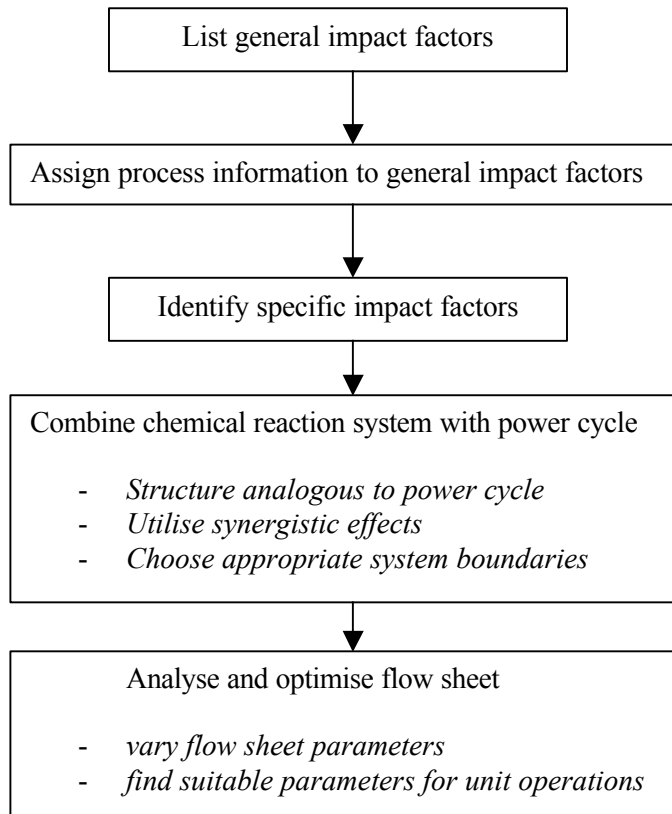

Figure 3.13 Summary of flow sheet design methodology.

3.3.2 Factors impacting on the flow sheet structure

Single pass or recycle operation

Placement of a turbine expander in a system without recycle will render an open process power cycle, with reactants flowing in and expanded product leaving the cycle. An example of a once-through adiabatic reactor process power cycle is shown in Figure 3.14. Note that any further product cooling and processing need not be included in the system boundary of the process gas cycle since these will have no influence on the power production. The heat released by the cycle is simply the difference between the enthalpies of streams 1 and 4.

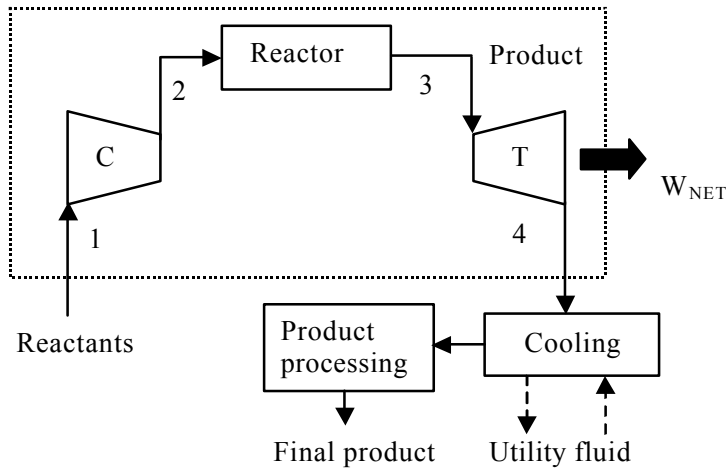

Figure 3.14 Once-through adiabatic reactor process power cycle.

In a system with recycle, the integration would result in a semi-closed cycle with a fraction of the working fluid being recycled and reactants and product entering and leaving the cycle. In a system with recycle there will be a separation operation in the recycle stream to separate product from the unreacted components that are recycled back to the reactor. This is shown in Figure 3.15.

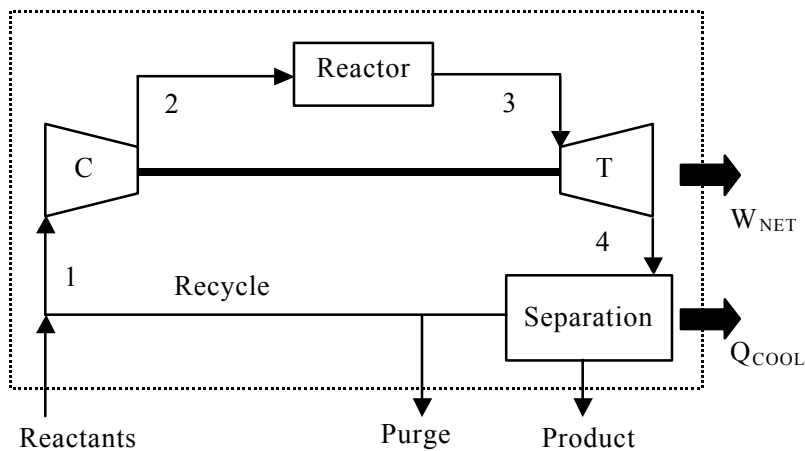

Figure 3.15 Adiabatic reactor process power cycle with recycle.

It now makes sense to include the separation operation within the system boundary due to the influence it will have on the state of the recycled stream and therefore the inlet to the compressor, stream 1. The heat released by the cycle is still the enthalpy difference between streams 1 and 4. However, if the recycle and separation step is included in the system boundary, as shown in Figure 3.15, the heat released will also be the enthalpy difference between the purge, product and reactant streams plus any heat that may be removed from the recycle stream to enable separation or for any other reasons.

Conditions required for reactor product processing

Further processing of the reactor product in a system with no recycle may dictate the outlet conditions of the expander placed behind the reactor. If the processing takes place at similar pressure to that of the reactor the following options can be explored to make expansion possible:

- process the product at a lower pressure if technically feasible or
- conduct the reaction at a higher pressure if feasible or
- expand the product gas after processing and exchange heat between the product gas and reactor effluent to utilise the reaction heat.

The last option will not be as attractive due to loss in heat quality with the additional heat exchange.

Recycle stream separation

The options to enable expansion given above are also applicable when considering separation of a product from a recycle stream. Expansion of the reactor product creates two pressure levels within the system. Separation on the lower pressure side, after the expander, will have the advantage of decreasing the amount of gas to be recompressed. If the separation can only take place at high pressure, the option of conducting the reaction at an even higher pressure to create a pressure difference can be explored. A system with three pressure levels may even be considered, e.g. expanding or compressing in two steps with separation in between.

Reactor operation

The most favourable case for power production using the process gas would be an adiabatic reactor operation wherein all the reaction heat is absorbed by the process gas. The heat is then utilised at the temperature of the reaction. This is however not always possible. In many cases the temperature of a reaction needs to be controlled to prevent reactor runaway or the temperature must be limited due to its negative effect on the reaction equilibrium or selectivity. In the case of an isothermal reactor a temperature increase across the reactor would be needed to at least allow a portion of the reaction heat to be absorbed by the process gas for use in the process gas cycle. The remaining reaction heat will be transferred to a utility fluid, most often steam, and can be utilised to produce power in a conventional steam cycle. These options for utilisation of reaction heat are shown in Figure 3.16. The process gas cycle and utility fluid cycles are presented as *heat engines* in the figure.

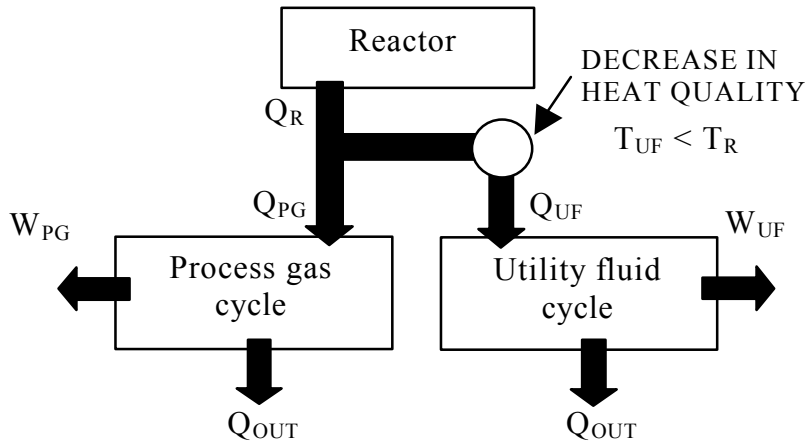

Figure 3.16 Options for the utilisation of reaction heat.

Purge gas

Purge gas can also be expanded in a separate expander, especially if the gas is purged from the high pressure side of a system. Combustible purge gas can be utilised as fuel to drive a gas turbine or as fuel gas for process fired heaters.

State of reactants and reactor products

It is beneficial for compression if reactants are in the liquid form. In such a case the process fluid will follow a Rankine type cycle. It is also possible to have two reactant streams, one in the liquid phase and one in the gas phase. The liquid phase reactant can then be pumped and the gas phase reactant compressed. This will result in a hybrid Rankine-Brayton type cycle. If the reaction products are in the gas phase, the liquid reactant would have absorbed a portion of the reaction heat in order to vaporise. However, in gas phase reactions most reactants are gases. If the reactant gas is at a high temperature, pre-cooling will reduce the work of the reactant compressor.

Product specifications such as its state and composition may for example dictate reactor conditions that are not necessarily optimal for power production. Product specifications can however not be compromised.

Process gas properties

Since the process gas becomes the working fluid of a power cycle its physical properties, such as specific heat ratio and lower condensation limit, will influence the power production capacity. Changes in gas composition also makes such a process gas cycle more difficult to model compared to a constant composition working fluid cycle, such as the steam cycle.

Depending on how drastically the physical properties change through the process gas cycle, constant properties may be assumed for a first round qualitative evaluation.

Volume change during chemical reaction

An increase in the number of moles (and hence volume) due to the reaction stoichiometry favours the expansion process. Expansion of larger volumes of gas would increase the work gained from the turbine expander. Many chemical reactions are however limited by chemical equilibrium. High-pressure operation and a decrease of volume during the reaction force the equilibrium in the desired direction.

3.4 Mathematical modelling of flow sheets

Once a flow sheet configuration or base case has been determined a *flow sheet analysis* is needed to find a suitable set of flow sheet conditions. The various flow sheet parameters that impact on a system integrated with a turbine expander are referred to as *design parameters*. In this section mathematical models are developed for typical process gas power cycles. These models will then be used to investigate the key design parameters relevant to the power and chemicals production.

3.4.1 Adiabatic reaction system with an equilibrium-limited reaction

Figure 3.17A shows a reactor system with recycle that is relevant to isothermal and adiabatic reactors. In Figure 3.17B the system is schematically presented as a heat engine where the temperature rise over the exothermic reactor is brought about by heat transfer to the working fluid from an external heat source. Q_{PG} is the heat transferred to the process gas working fluid and is dependent on the conversion and heat of reaction. The net work from the process gas power cycle equals the net heat transfer to the cycle:

$$-W_{PG} = Q_{PG} + Q_{OUT} \quad \dots 3.4$$

The performance of the system undergoing a power cycle is described in terms of the thermal efficiency, η_{PG} , which is the extent to which the energy added to the system, Q_{PG} , is converted to work:

$$-W_{PG} = \eta_{PG} Q_{PG} \quad \dots 3.5$$

It is now assumed that the following equilibrium reaction takes place in an adiabatic reactor:

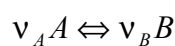

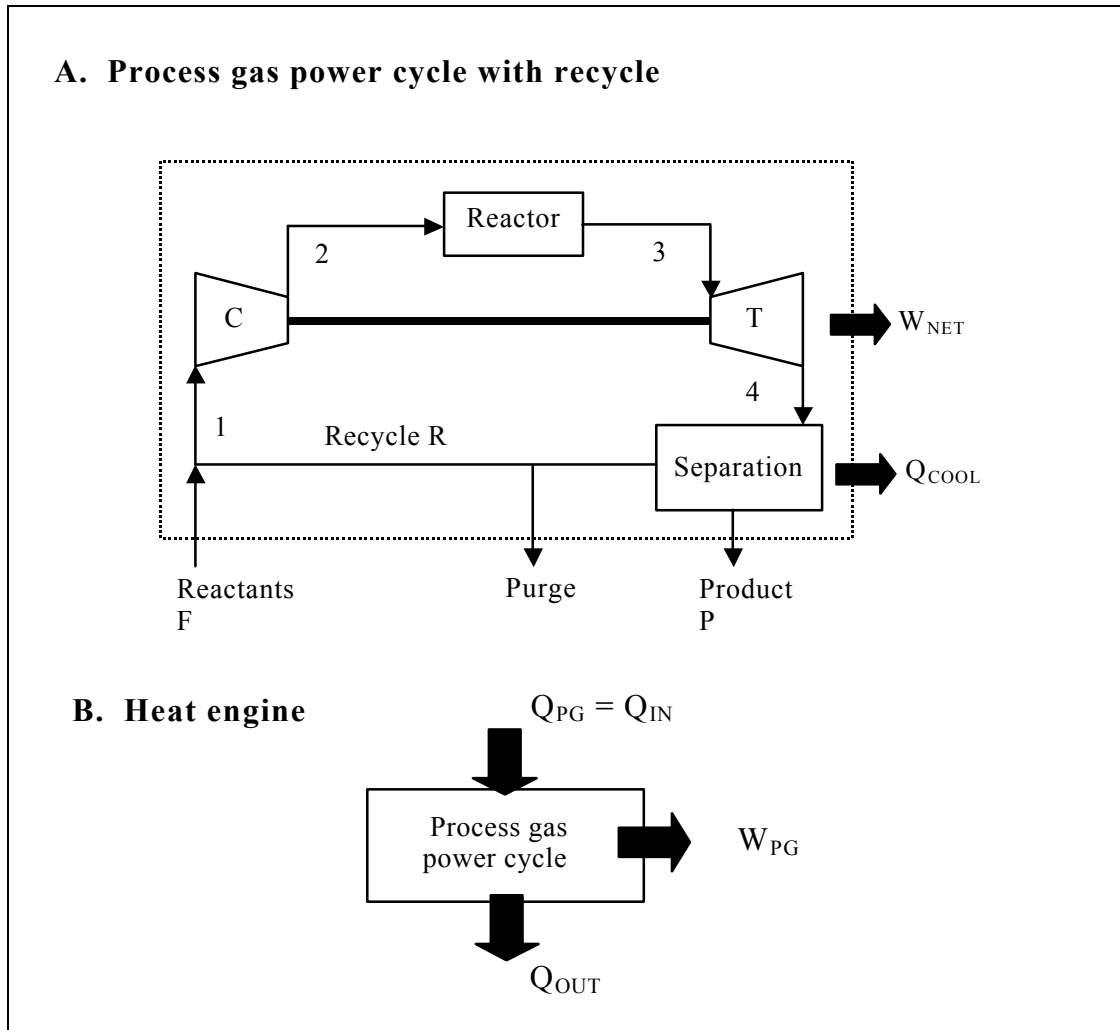

Figure 3.17 Modelling of process gas power cycles.

Air-standard analysis is an idealisation that is often used to study gas turbine cycles. Such analyses are used to deduce qualitative indications of cycle performance. The models developed here uses the same assumptions as for air-standard analysis (Moran and Shapiro, 1995), namely:

- the working fluid behaves as an ideal gas and therefore $C_p = \frac{kR}{k-1}$
- the temperature rise that would be achieved in the reaction (or combustion) process is brought about by heat transfer from an external heat source.

Another assumption is that the specific heats (C_p , C_v and k) of the gas remains constant through the cycle, i.e. at points 1 to 4 in Figure 3.17A. This also means that the reaction heat does not depend on the temperature. The following further assumptions are also made:

- $P_1 = P_F = P_R = P_4$, i.e. the pressure losses between point 4 and 1 in the system is negligible compared to the pressure difference across the compressor/expander

- pressure loss through the reactor is negligible compared to pressure difference over compressor, therefore $P_2 = P_3$
- $T_1 = T_F = T_R$
- all of the product B is removed from the recycle in the separation step
- the purge rate is negligible
- ΔH_R and C_p do not depend on temperature and moreover C_p does not depend on gas composition
- pure A is fed into the system as reactant (stream F)

The following equations are relevant for the various unit operations:

Compressor

Mole balance: $n_1 = n_2 = n_{A2} = n_{A1}$...3.6

Isentropic compression of an ideal gas: $\frac{T_2}{T_1} = \left(\frac{P_2}{P_1}\right)^{\frac{k-1}{k}}$...3.7

$$W_C = \frac{n_1 k R T_1}{k-1} \left[\left(\frac{P_2}{P_1}\right)^{\frac{k-1}{k}} - 1 \right] \quad \dots 3.8$$

Expander

Mole balances: $n_{A4} = n_{A3}$...3.9

$$n_{B4} = n_{B3} \quad \dots 3.10$$

Isentropic expansion of an ideal gas: $\frac{T_4}{T_3} = \left(\frac{P_4}{P_3}\right)^{\frac{k-1}{k}}$...3.11

$$W_T = \frac{n_3 k R T_3}{k-1} \left[\left(\frac{P_4}{P_3}\right)^{\frac{k-1}{k}} - 1 \right] \quad \dots 3.12$$

Recycle mix

Mole balance of component A: $n_{A1} = n_{AF} + n_{AR}$...3.13

Separator

$$\text{Component mole balances:} \quad n_{AR} = n_{A4} \quad \dots 3.14$$

$$n_{BP} = n_{B4} \quad \dots 3.15$$

$$\text{Total energy balance} \quad W_{PG} = W_C + W_T = Q_{PG} - Q_{OUT} \quad \dots 3.16$$

Reactor

$$\text{Component mole balances:} \quad n_{A3} = n_{A2} - n_{A2}x_A \quad \dots 3.17$$

$$n_{B3} = \frac{v_B}{v_A} n_{A2} x_A \quad \dots 3.18$$

$$\text{Energy balance:} \quad Q_{PG} = -x_A n_{A2} \Delta H_R = -n_{A2} C_p (T_2 - T_3) \quad \dots 3.19$$

Equilibrium limited reaction

Many exothermic reactions are carried out at high temperature since this is dictated by kinetics. At such high temperatures the chemical conversion is restricted by reaction equilibrium. Due to low conversion unconverted reactants are recycled back to the reactor inlet. In the case of exothermic reactions the *Van't Hoff equation* shows that the equilibrium constant decreases with an increase in the temperature T_3 :

$$\frac{d \ln K}{dT} = \frac{\Delta H_R}{RT_3^2}$$

Integration of the Van't Hoff equation gives:

$$\ln K = -\frac{\Delta H_R}{RT_3} + C \quad \dots 3.20$$

The equilibrium constant, K , is defined as follows:

$$K = \frac{y_B^{v_B}}{y_A^{v_A}} \left(\frac{P_3}{P_{ref}} \right)^{v_B - v_A}$$

and in terms of the number of moles present at equilibrium:

$$K = \frac{n_{B3}^{v_B}}{n_{A3}^{v_A}} \left(\frac{P_3 / P_{ref}}{n_T} \right)^{v_B - v_A} \quad \dots 3.21$$

where

$$P_{ref} = 1 \text{ bar}$$

$$y_i = \frac{n_i}{n_T}$$

n_i amount of component i in equilibrium mixture

n_T total number of moles in mixture, also including all inert components present
($n_T = n_3$)

Calculation of W_{PG}

Since the process gas power cycle has two products namely power and a chemical, an equation to calculate W_{PG} will be useful. Such an equation can be used to predict the influence of various parameters on W_{PG} .

It is assumed that the following parameters are known:

$n_F, T_F, P_F, k, P_{ref}, v_A, v_B, \Delta H_R$ and P_{ratio}

where P_{ratio} is defined as follows:

$$\frac{P_2}{P_1} = \frac{P_3}{P_4} = P_{ratio} \quad \dots 3.22$$

W_{PG} is obtained from equations 3.8, 3.12 and 3.22 in terms of P_{ratio}, T_1, T_3, n_1 and n_3 as follows:

$$\begin{aligned} W_{PG} &= W_C + W_T \\ &= \frac{n_1 k R T_1}{k-1} \left[\left(\frac{P_2}{P_1} \right)^{\frac{k-1}{k}} - 1 \right] + \frac{n_3 k R T_3}{k-1} \left[\left(\frac{P_4}{P_3} \right)^{\frac{k-1}{k}} - 1 \right] \\ &= \frac{kR}{k-1} \left[n_1 T_1 \left[P_{ratio}^{\frac{k-1}{k}} - 1 \right] + n_3 T_3 \left[P_{ratio}^{\frac{1-k}{k}} - 1 \right] \right] \quad \dots 3.23 \end{aligned}$$

From equations 3.6, 3.7, 3.13, 3.14 and 3.17 the following expression for n_1 is obtained:

$$n_1 = n_{A1} = n_{A2} = \frac{n_{AF}}{x_A} \quad \dots 3.24$$

Previously the following was assumed for T_1 :

$$T_1 = T_F \quad \dots 3.25$$

From equations 3.17, 3.18 and 3.24 the following expression for n_3 is obtained:

$$\begin{aligned} n_3 &= n_{A3} + n_{B3} \\ n_3 &= \frac{n_{AF}}{x_A} \left(1 - x_A + \frac{v_B}{v_A} x_A \right) \end{aligned} \quad \dots 3.26$$

From the energy balance across the reactor (equation 3.19) and equations 3.7 and 3.22 the following expression for T_3 is obtained:

$$T_3 = T_F P_{ratio}^{\frac{k-1}{k}} - \frac{x_A \Delta H_R}{C_p} \quad \dots 3.27$$

Substitution of equations 3.24, 3.25 and 3.26 into equation 3.23 renders:

$$W_{PG} = \frac{kR}{k-1} \frac{n_{AF}}{x_A} \left[T_F \left[P_{ratio}^{\frac{k-1}{k}} - 1 \right] + T_3 \left[1 - x_A \left(1 - \frac{n_B}{n_A} \right) \right] \left[P_{ratio}^{\frac{1-k}{k}} - 1 \right] \right] \quad \dots 3.28$$

T_3 and x_A are still not known and will be determined by simultaneously solving equation 3.27 and an equation describing the relation between T_3 and the equilibrium constant, K . Equations 3.21, 3.17, 3.18 and 3.24 are substituted into equation 3.20 to give:

$$-\frac{\Delta H_R}{RT_3} + C = \ln \left\{ \frac{\left(\frac{v_B}{v_A} n_{AF} \right)^{v_B}}{\left(\frac{n_{AF}}{x_A} - n_{AF} \right)^{v_A}} \left[\frac{P_3}{\frac{n_{AF}}{x_A} - n_{AF} + \frac{v_B}{v_A} n_{AF}} \right]^{v_B - v_A}} \right\} \quad \dots 3.29$$

Equation 3.27 for T_3 is then substituted into equation 3.29 to derive the following equation for calculation of the conversion x_A :

$$x_A = \frac{C_p T_F P_{ratio}^{\frac{k-1}{k}}}{\Delta H_R} - \frac{C_p}{R} \left[C - \ln \left\{ \frac{\left(\frac{v_B}{v_A} n_{AF} \right)^{v_B}}{\left(\frac{n_{AF}}{x_A} - n_{AF} \right)^{v_A}} \left[\frac{P_3}{\frac{n_{AF}}{x_A} - n_{AF} + \frac{v_B}{v_A} n_{AF}} \right]^{v_B - v_A}} \right\} \right]^{-1} \quad \dots 3.30$$

W_{PG} can now be calculated as follows:

- Solve for x_A using equation 3.30.
- Solve for T_3 using equation 3.27.
- Solve for W_{PG} using equation 3.28.

3.4.2 Adiabatic reaction system with reaction kinetics

All assumptions and equations are similar to the previous model except for the van't Hoff equation that is not used in this case.

It is assumed that the reactor is a steady-state flow stirred-tank adiabatic reactor. The mixing is therefore complete so that the properties of the reaction mixture are uniform in all parts of the vessel. The properties of the exit stream are therefore the same as those of the reaction mixture.

It is further assumed that the following irreversible reaction takes place in the reactor:

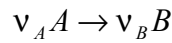

It is also assumed that the rate of disappearance of A is first order with respect to A:

$$r_A = x_A n_{A2} = k_r C_A m_c \quad \dots 3.31$$

where m_c is the mass of catalyst.

For an elementary process the Arrhenius equation describes the dependency of the reaction rate constant, k_r , on the temperature:

$$k_r = k_{r0} e^{-E/RT_3} \quad \dots 3.32$$

The concentration of A in equation 3.31 is now written in terms of the partial pressure of A and the temperature at the reactor outlet:

$$r_A = k_r \frac{P_A}{RT_3} m_c \quad \dots 3.33$$

The partial pressure of A is now written in terms of P_3 :

$$P_A = y_A P_3 = \frac{n_{A3}}{n_T} P_3 \quad \dots 3.34$$

Substitution of equation 3.34 and 3.32 into 3.33 yields:

$$r_A = x_A n_{A2} = k_{r0} e^{-E/RT_3} \frac{n_{A3}}{n_T} \frac{P_3}{RT_3} m_c \quad \dots 3.35$$

Substitution of the mole balances, equations 3.17 and 3.18 into equation 3.35 yields:

$$x_A n_{A2} = k_{r0} e^{-E/RT_3} \frac{P_3}{RT_3} \left[\frac{1 - x_A}{1 - x_A + \frac{v_B}{v_A} x_A} \right] m_c \dots 3.36$$

Substitution of equation 3.24 into 3.36 yields:

$$n_{AF} = k_{r0} e^{-E/RT_3} \frac{P_3}{RT_3} \left[\frac{1 - x_A}{1 - x_A + \frac{v_B}{v_A} x_A} \right] m_c \dots 3.37$$

Equation 3.27 for T_3 is then substituted into 3.37 to derive the following equation for calculation of the conversion x_A :

$$x_A = \frac{C_p T_F P_{ratio}^{\frac{k-1}{k}}}{\Delta H_R} - k_{r0} e^{-E/RT_3} \frac{C_p P_3}{R \Delta H_R n_{AF}} \left[\frac{1 - x_A}{1 - x_A + \frac{v_B}{v_A} x_A} \right] m_c \dots 3.38$$

W_{PG} can now be calculated as follows:

- Solve for x_A using equation 3.38.
- Solve for T_3 using equation 3.27.
- Solve for W_{PG} using equation 3.28.

3.4.3 Adiabatic reaction system with reaction kinetics and no recycle

Figure 3.14 shows this kind of system. The conversion is high enough so that no recycle is needed. It is also not necessary to include the downstream product processing into the power cycle system boundaries, as indicated in Figure 3.14. W_{PG} can be calculated easily by adapting the equations developed previously as follows:

- replace T_F with T_1
- replace n_{AF} with $x_A n_1$ (note $n_{A1} = n_1$)

then

$$x_A = \frac{C_p T_1 P_{ratio}^{\frac{k-1}{k}}}{\Delta H_R} - k_{r0} e^{-E/RT_3} \frac{C_p P_3}{R \Delta H_R x_A n_1} \left[\frac{1 - x_A}{1 - x_A + \frac{v_B}{v_A} x_A} \right] m_c \dots 3.39$$

$$T_3 = T_1 P_{ratio}^{\frac{k-1}{k}} - \frac{x_A \Delta H_R}{C_p} \quad \dots 3.40$$

and

$$W_{PG} = \frac{kR}{k-1} n_1 \left[T_1 \left[P_{ratio}^{\frac{k-1}{k}} - 1 \right] + T_3 \left[1 - x_A \left(1 - \frac{v_B}{v_A} \right) \right] \left[P_{ratio}^{\frac{1-k}{k}} - 1 \right] \right] \quad \dots 3.41$$

3.5 Flow sheet design parameters

In this section the most important flow sheet parameters that impact on a system integrated with a turbine expander are discussed and investigated. These parameters are referred to as *design parameters*. The mathematical models developed in the previous section are used in this investigation. It is therefore important to keep in mind the assumptions that were made in the derivation of these models.

3.5.1 Heat input and thermal efficiency

The heat transferred to the process gas, Q_{PG} , depends on the conversion and the heat of the reaction. Thermal efficiency will determine what portion of this heat is converted to work. For an ideal air-standard Brayton cycle with constant heat capacity (C_p), the thermal efficiency is a function of pressure ratio and specific heat ratio:

$$\eta = 1 - \left(\frac{P_{out}}{P_{in}} \right)^{\frac{1-k}{k}} \quad \dots 3.2$$

Equation 3.2 can be used to give an indication of thermal efficiency provided the mole flow rate through the cycle remains constant and the other assumptions for an air-standard analysis are kept in mind. At least once Q_{PG} is known, one can obtain an estimate of the amount of work that may be obtained and decide whether it is worth it to proceed with further development of a design.

3.5.2 Expander and compressor inlet temperatures

The work of compression or expansion is proportional to the inlet temperature:

$$W = \frac{nkRT_{in}}{k-1} \left[\left(\frac{P_{out}}{P_{in}} \right)^{\frac{k-1}{k}} - 1 \right] \quad \dots 3.3$$

High turbine inlet temperatures and low compressor inlet temperatures are desirable. The potential for improvement of a reaction system by integration with a turbine expander also increases at higher reaction product temperatures. High reaction product temperatures would mean that downstream product cooling is probably done with a higher temperature driving force corresponding to higher thermodynamic losses.

Available turbine expanders for process applications can only achieve inlet temperatures up to 870 °C. Gas turbine blade cooling techniques will have to be used to accommodate higher temperatures. This is discussed in more detail in section 10.5.

3.5.3 Gas flow rate and composition

Flow rate of process gas will determine the size of the power and chemicals production system. Flow rate will not influence thermal efficiency, therefore, once the pressures and temperatures in the system are fixed, flow rate can be adjusted to achieve the desired amount of power and chemical product. Costs of increasing the equipment sizes should be traded off against increased production rates.

Composition of the process gas will determine physical properties such as specific heat ratio, which is important for power production. In a system with reaction, composition will change and therefore accurate modelling of the cycle becomes more difficult.

Properties such as viscosity and density will determine friction pressure loss through piping and equipment. However, in the previously developed models these losses are assumed negligible compared to the pressure ratio over the compressor and expander.

Depending on how drastic the physical properties change through the process gas cycle, constant properties may be assumed for a first round qualitative evaluation, as was done in the development of the mathematical models.

3.5.4 Pressure ratio

Pressure ratio is most important for power production. The thermal efficiency and work of compression and expansion depends on pressure ratio. The pressure ratio will also determine the pressure downstream of the expander where further product processing takes place, especially in systems with recycle where the product is separated from non-converted reactants.

In this investigation a constant-conversion model is first used to investigate the effect of pressure ratio on power production. This kind of model will resemble the conventional air-standard cycle. In a conventional cycle the conversion of reactants is high and a recycle is not

needed. If one assumes that the conversion is constant, only equations 3.40 and 3.41 are needed to model the system. The results of this investigation will be useful in the sense that the models with non-constant conversion can be compared to the constant-conversion ones.

Secondly, the two adiabatic reaction system models are used to show how pressure ratio affects the parameters in a power cycle driven by a chemical reactor. For a chosen reaction system the gas properties (C_p , k) and parameters relevant to the reaction (v_A , v_B , ΔH_R , P_3) are fixed. Inspection of equation 3.28 then reveals that the feed flow rate, n_F , and temperature, T_F , as well as the pressure ratio, P_{ratio} , are the independent variables that can be adjusted to influence W_{PG} and product flow rate. The conversion, x_A , is determined by the reaction temperature, T_3 , and will therefore change as P_{ratio} is adjusted. It was decided to keep n_F and T_F constant. A constant feed flow rate means constant production rate of product and is therefore a realistic scenario.

Note that the results for the reaction system with reaction kinetics are only reported in the next section since the effect of volume change during the chemical reaction is investigated simultaneously to that of pressure ratio.

Constant-conversion model

An analysis was done for the following exothermic reaction:

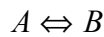

Table 3.3 shows the values that were assumed for the known parameters.

Table 3.3 Data used to illustrate effect of pressure ratio on constant-conversion system with no recycle.

Parameter	Unit	Value
C_p	kJ/kmol.K	29.1
k	-	1.4
ΔH_R	kJ/kmol A	-20 000
n_1	kmol/s	2.07
T_1	°C	20
x_A	-	1.0

The heat transferred to the gas, Q_{PG} , is constant and equal to 41 400 kW. Figure 3.18 shows how T_3 increases with pressure ratio. This will benefit the expansion. Thermal efficiency as well as W_{PG} increases with pressure ratio, as shown in Figure 3.19 and 3.20, however these relations are not linear.

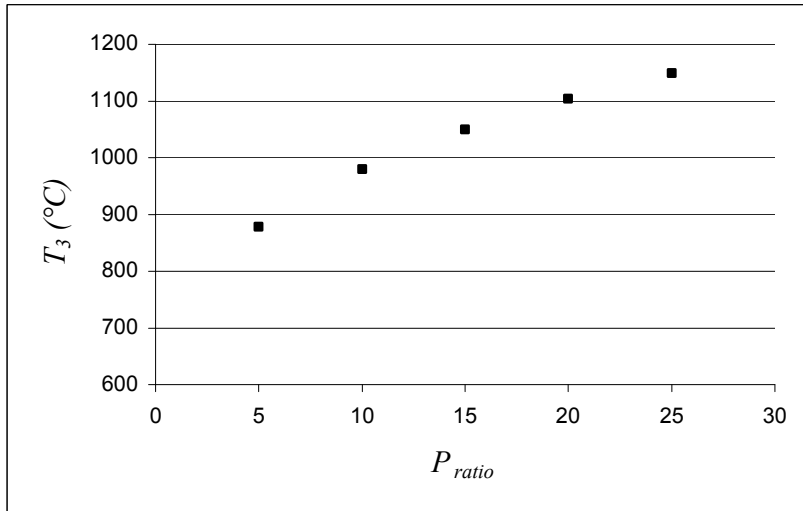

Figure 3.18 T_3 versus P_{ratio} for constant-conversion system.

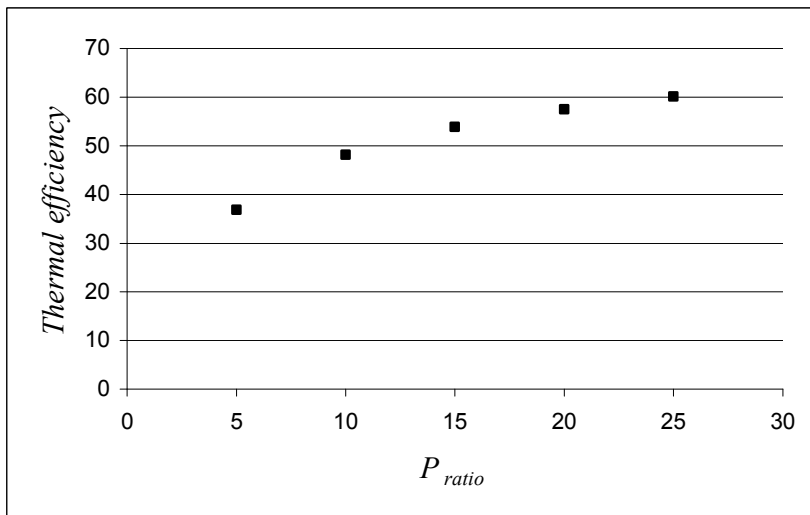

Figure 3.19 Thermal efficiency versus P_{ratio} for constant-conversion system.

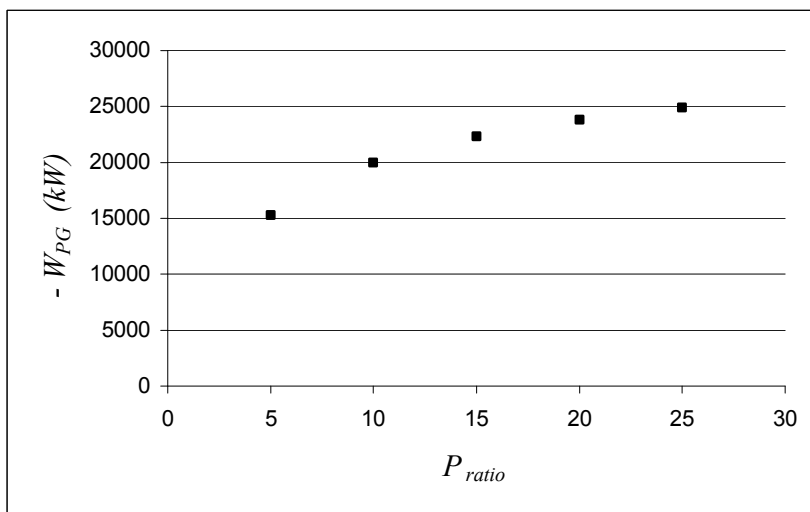

Figure 3.20 W_{PG} versus P_{ratio} for constant-conversion system.

Adiabatic reaction system with an equilibrium-limited reaction

An analysis was done for the following exothermic reaction:

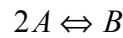

Table 3.4 shows the values that were assumed for the known parameters. Figure 3.21 shows how T_3 increases with P_{ratio} . Associated with the increase in T_3 , is a decrease in x_A , as shown in Figure 3.22. At lower conversion less reaction heat is released to drive the process gas power cycle. However, since the feed rate, n_{AF} , is kept constant, the recycle flow rate increases as shown in Figure 3.23. Subsequently the heat transferred to the process gas, Q_{PG} , is constant and equal to 41 400 kW in this case. It is important to note that when large mass flows occur in the cycle the equipment in the system will be larger and more expensive. *These considerations are important for economic analyses.*

Table 3.4 Data used to illustrate effect of pressure ratio on adiabatic reaction system with equilibrium-limited reaction.

Parameter	Unit	Value
C_p	kJ/kmol.K	29.1
k	-	1.4
ΔH_R	kJ/kmol A	-20 000
n_{AF}	kmol/s	2.07
T_F	°C	40
P_3	bar	213
C	-	-11.8

Figure 3.24 shows W_{PG} versus P_{ratio} . (Note that the negative of W_{PG} is plotted to make the graph easier to read). It is clear that W_{PG} has a maximum value at a certain pressure ratio, this is quite different to what happens in the constant-conversion model. The point of maximum W_{PG} also coincides with the maximum efficiency, shown in Figure 3.25. However, maximum efficiency coincides with a fairly large recycle flow rate and large expensive equipment may be needed to obtain this efficiency. It may be desirable to operate at a pressure ratio that yields the most work per mole flow of the recycle stream. Figure 3.26 shows that W_{PG}/n_R in kJ/(kmol recycle flow) reaches a maximum at a pressure ratio of 5.

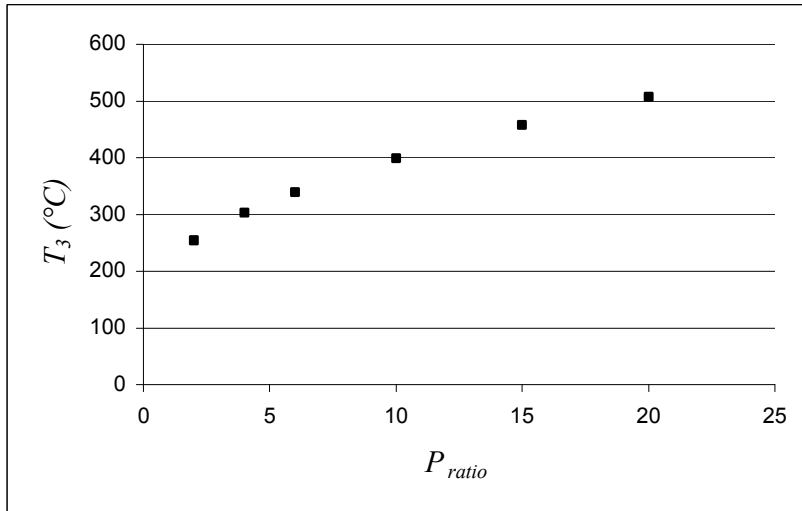

Figure 3.21 T_3 versus P_{ratio} for adiabatic reaction system with equilibrium-limited reaction.

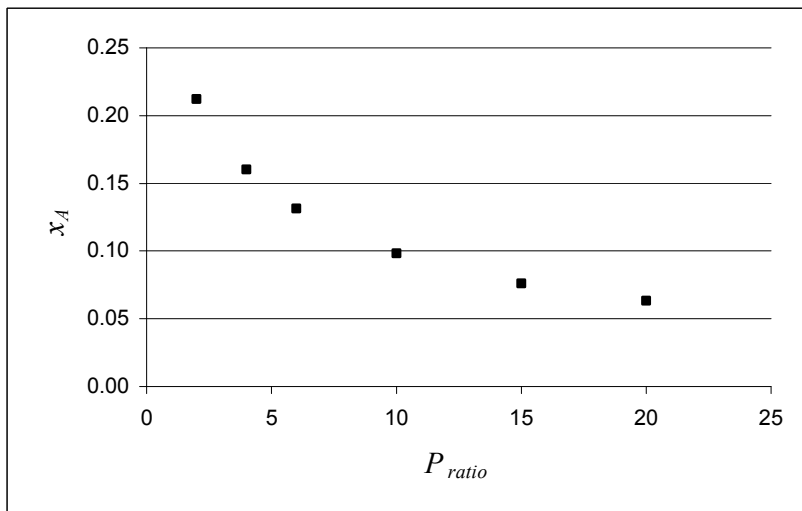

Figure 3.22 x_A versus P_{ratio} for adiabatic reaction system with equilibrium-limited reaction.

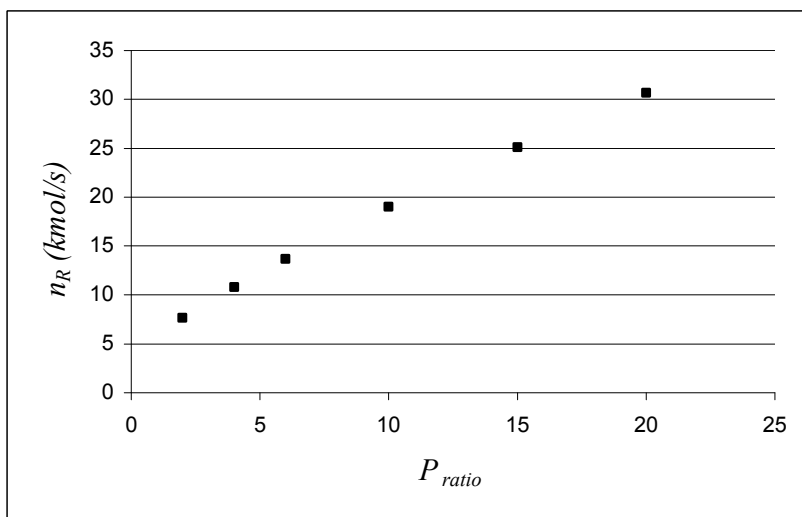

Figure 3.23 n_R versus P_{ratio} for adiabatic reaction system with equilibrium-limited.

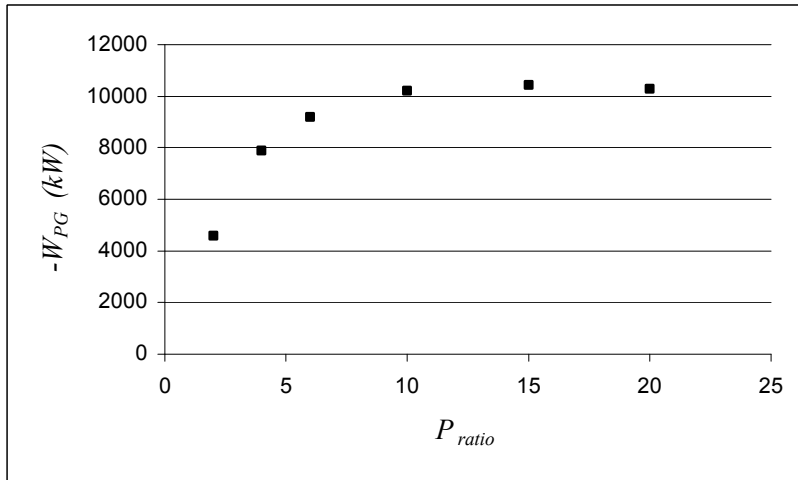

Figure 3.24 W_{PG} versus P_{ratio} for adiabatic reaction system with equilibrium-limited reaction.

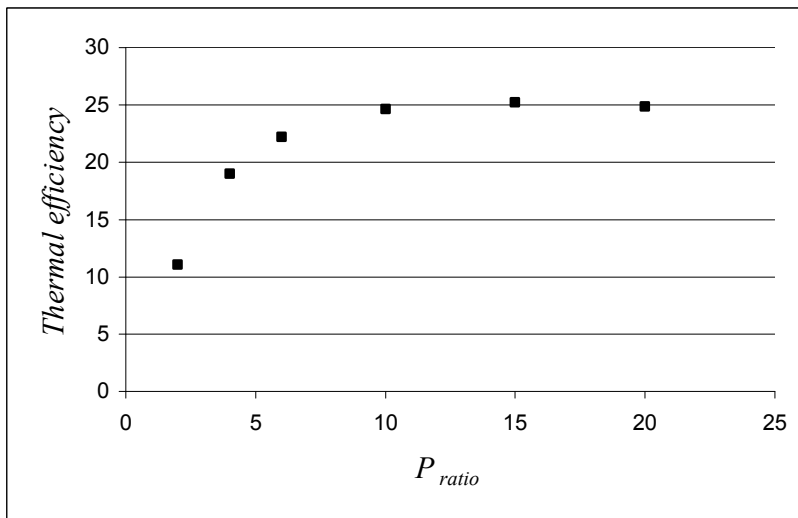

Figure 3.25 Thermal efficiency versus P_{ratio} for adiabatic reaction system with equilibrium-limited reaction.

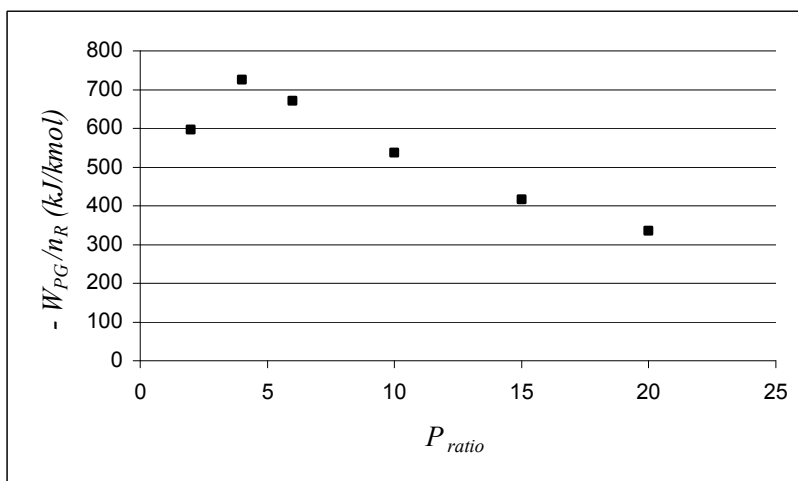

Figure 3.26 W_{PG}/n_R versus P_{ratio} for adiabatic reaction system with equilibrium-limited reaction.

3.5.5 Volume change during chemical reaction

The work of compression or expansion is proportional to the mole flow rate. An increase in the number of moles during the reaction will therefore favour the power production since the mole flow rate for expansion is higher compared to the rate for compression. The effect of volume change is illustrated using the adiabatic reaction system with reaction kinetics.

Adiabatic reaction system with reaction kinetics

The parameters n_F and T_F are kept constant and it is shown how the system is influenced by changes in P_{ratio} as well as volume change during the reaction.

Analyses were done for the following reactions to illustrate the effect of volume change:

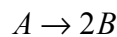
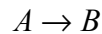
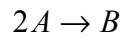

Table 3.5 shows the values that were assumed for the known parameters. Since the heat of reaction and feed mole flow rate are the same as for the previous model analysis, Q_{PG} is also equal to 41 400 kW in this analysis. Results were similar to that obtained for the model with an equilibrium limited reaction, except for T_3 which *decreased* with an increase in pressure ratio. To illustrate the usefulness of the model, the effect of a volume change was studied. Results are reported in Figures 3.27 to 3.32 for the three reactions. Maximum values for W_{PG} and thermal efficiency were not obtained although the values do start to level off with increasing pressure ratio. The results show that an increase in volume has a significant effect on thermal efficiency and the amount of work obtained.

Table 3.5 Data used to illustrate effect of pressure ratio and volume change on adiabatic reaction system with reaction kinetics.

Parameter	Unit	Value
C_p	kJ/(kmol.K)	29.1
k	-	1.4
ΔH_R	kJ/kmol A	-20 000
n_{AF}	kmol/s	2.07
T_F	°C	40
P_3	bar	40
k_{r0}	$m^3/(kg.s)$	1×10^{11}
E	kJ/kmol	180 000
m_c	kg	500

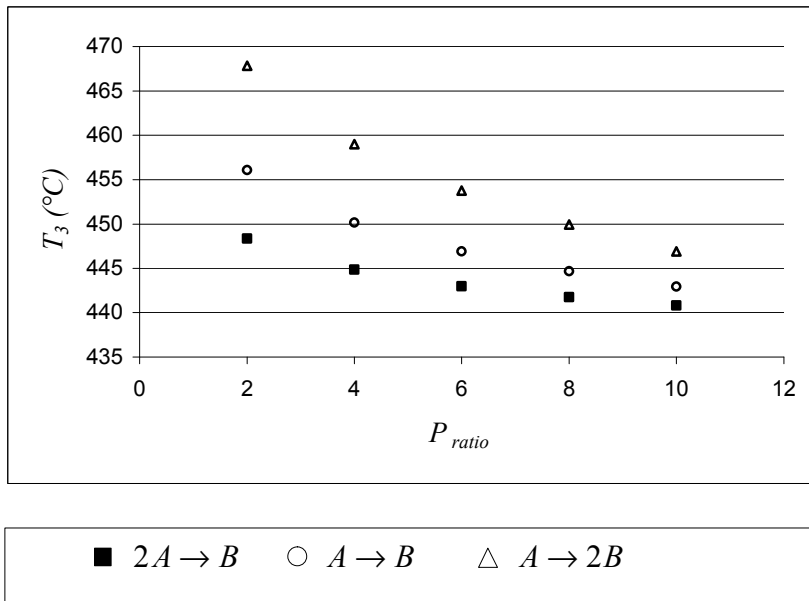

Figure 3.27 T_3 versus P_{ratio} for an adiabatic reaction system with reaction kinetics.

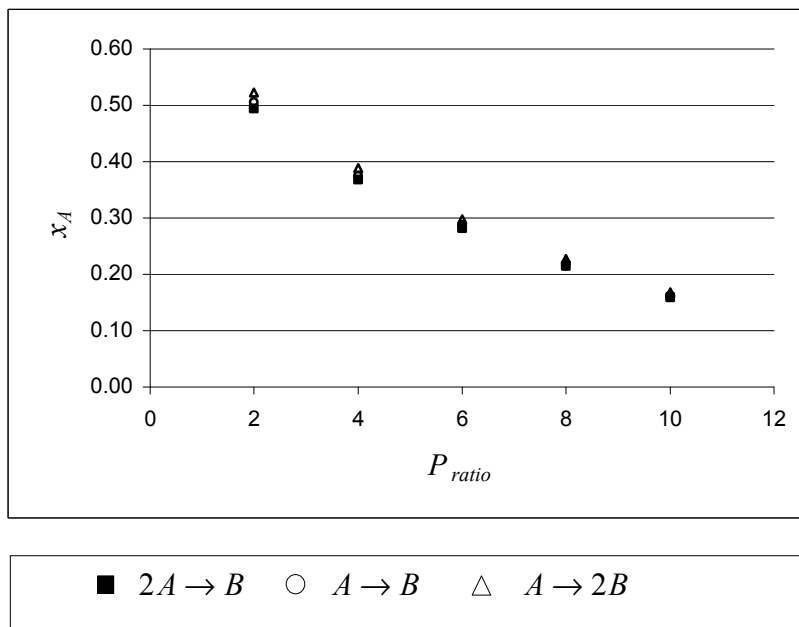

Figure 3.28 x_A versus P_{ratio} for an adiabatic reaction system with reaction kinetics.

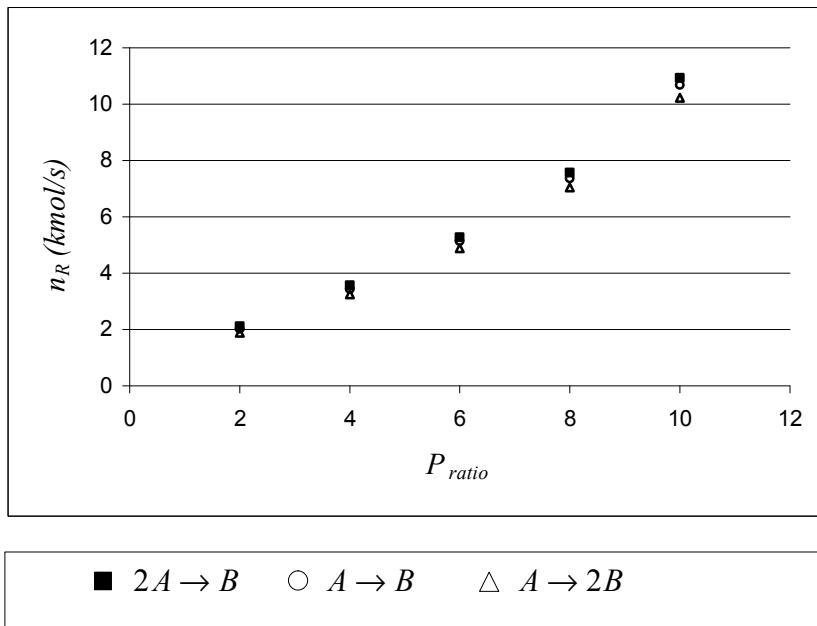

Figure 3.29 n_R versus P_{ratio} for an adiabatic reaction system with reaction kinetics.

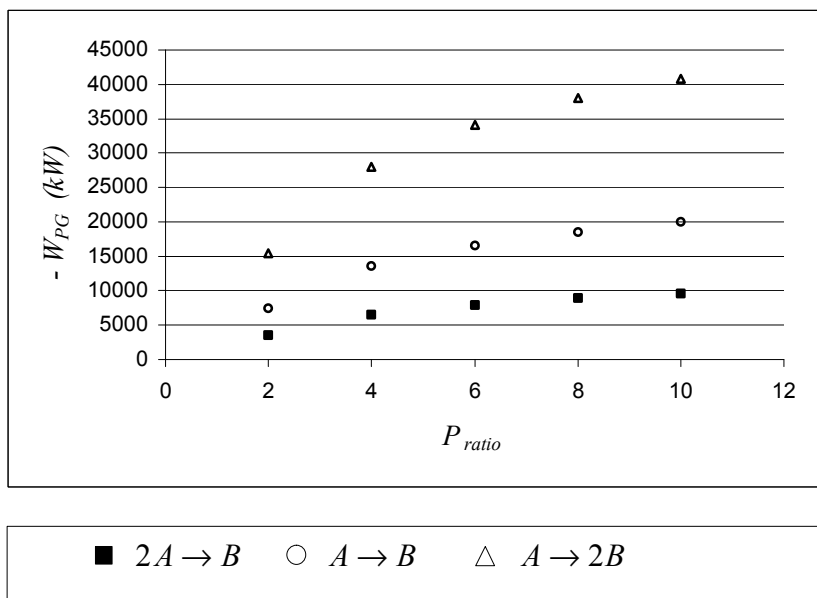

Figure 3.30 W_{PG} versus P_{ratio} for an adiabatic reaction system with reaction kinetics.

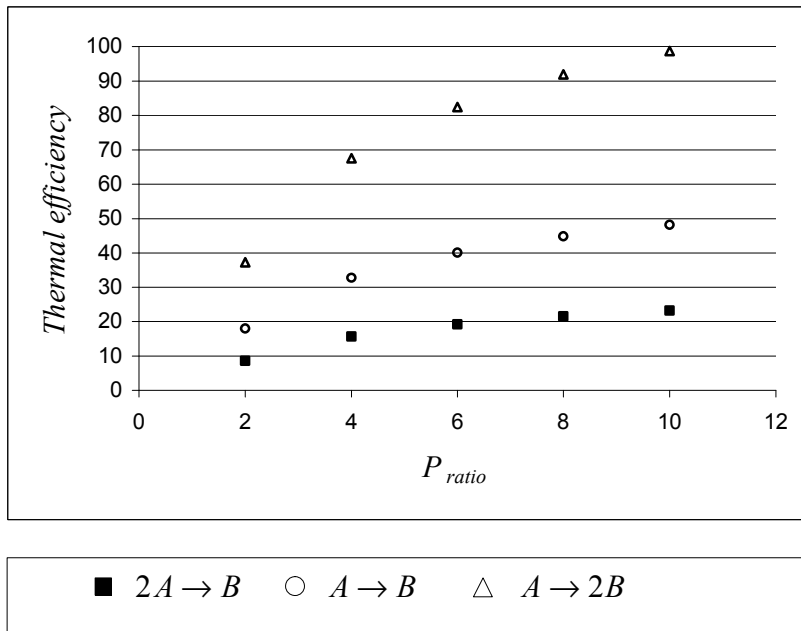

Figure 3.31 Thermal efficiency versus P_{ratio} for an adiabatic reaction system with reaction kinetics.

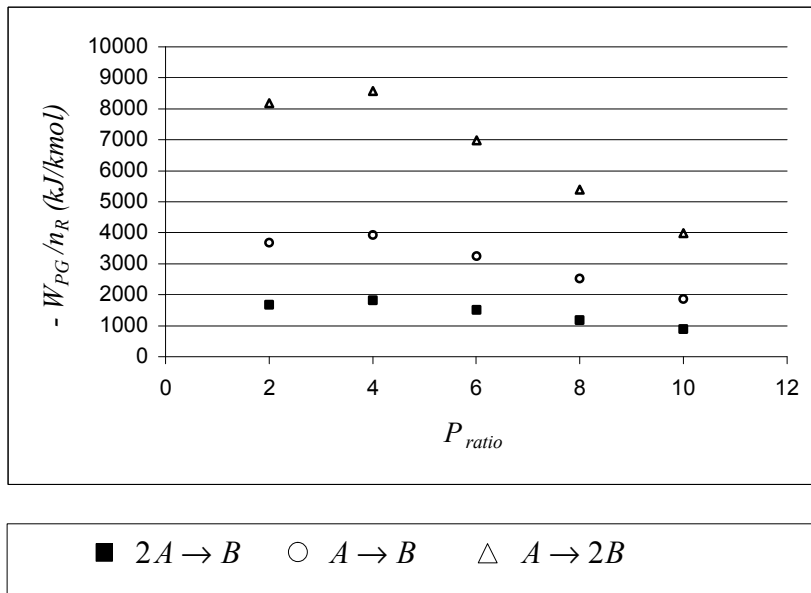

Figure 3.32 W_{PG}/n_R versus P_{ratio} for an adiabatic reaction system with reaction kinetics.

3.5.6 Specific heat ratio of the working fluid

In the mathematical models the ideal gas assumption was made and therefore C_p will change with k according to the following relation:

$$C_p = \frac{kR}{k-1}$$

The constant-conversion model is first used to investigate the effect of k (equations 3.40 and 3.41). Thereafter the effect of k is investigated for the adiabatic reaction system with equilibrium-limited reaction. All parameters relevant to the reaction (v_A , v_B , ΔH_R , P_3) are fixed. Feed flow rate, feed temperature and pressure ratio is also fixed. A constant feed flow rate means constant production rate of product.

Constant-conversion model

An analysis was done for the following exothermic reaction:

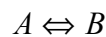

Table 3.6 shows the values that were assumed for the known parameters. The heat transferred to the gas, Q_{PG} , is constant and equal to 41 400 kW. Figures 3.33 through 3.35 show how T_3 , η_{PG} and W_{PG} increase as k is increased. The effect of k on the individual compression and expansion steps are shown in Figure 3.36 and 3.37 respectively. Figure 3.36 shows that lower k values are desirable for compression. In Figure 3.37 the effect of k on expansion is shown for increasing T_3 and a constant T_3 . In reality lower k values is also desirable for the expansion step, however, for the total system higher k values are desirable!

Table 3.6 Data used to illustrate effect of specific heat ratio on constant-conversion system with no recycle.

Parameter	Unit	Value
P_{ratio}	-	10
ΔH_R	kJ/kmol A	-20 000
n_1	kmol/s	2.07
T_1	°C	20
x_A	-	1.0

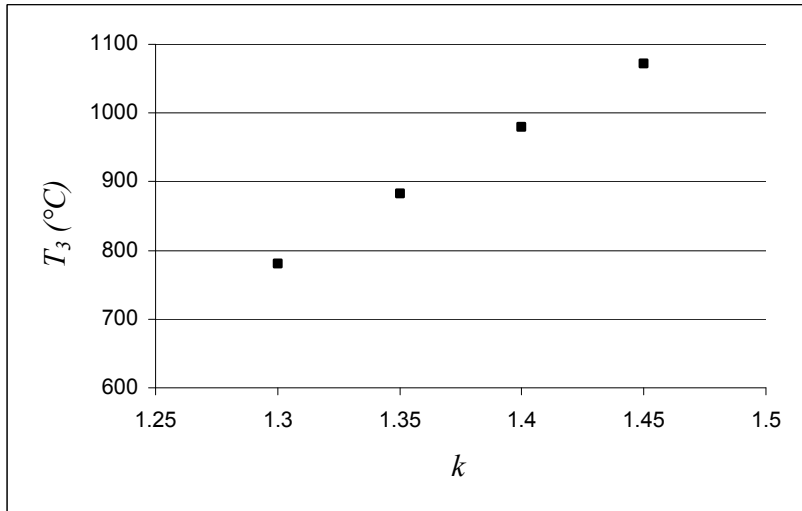

Figure 3.33 T_3 versus k for constant-conversion system.

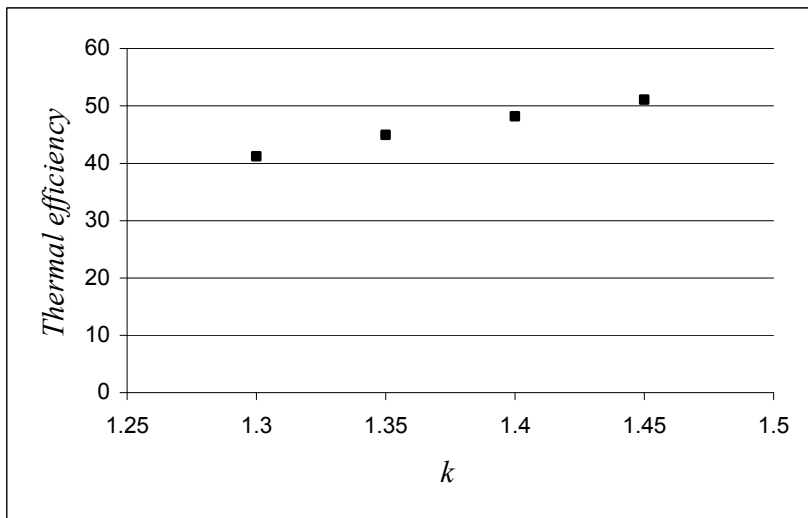

Figure 3.34 Thermal efficiency versus k for constant-conversion system.

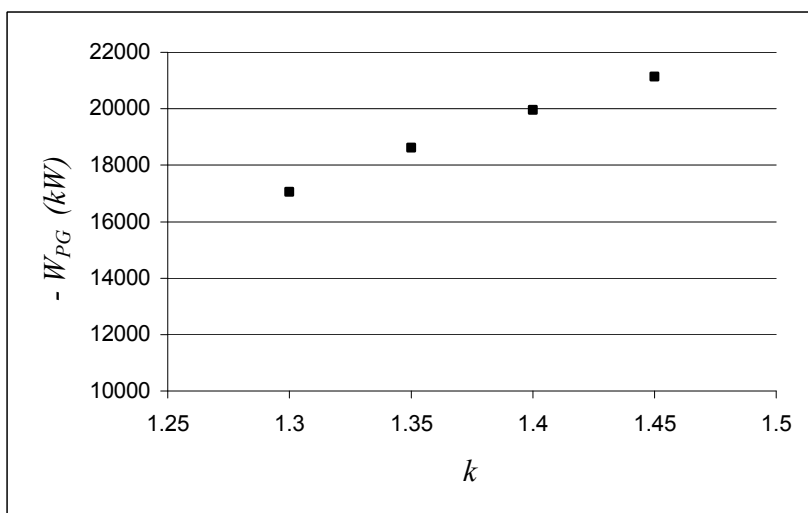

Figure 3.35 W_{PG} versus k for constant-conversion system.

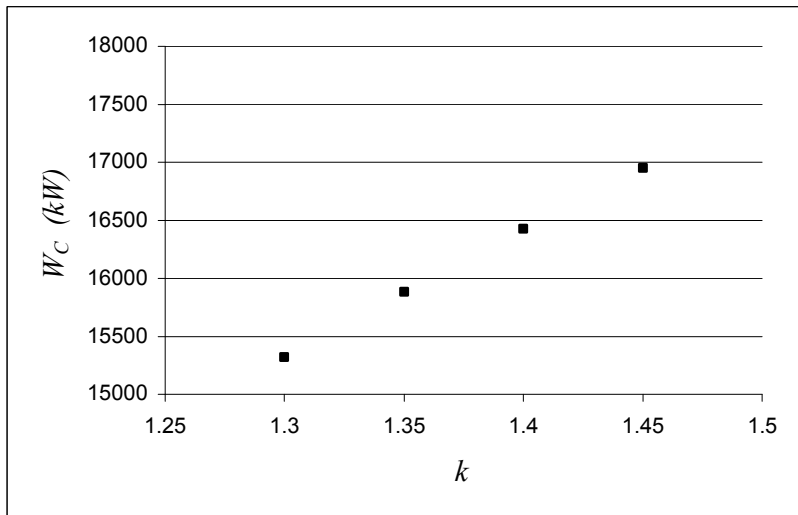

Figure 3.36 W_C versus k for constant-conversion system.

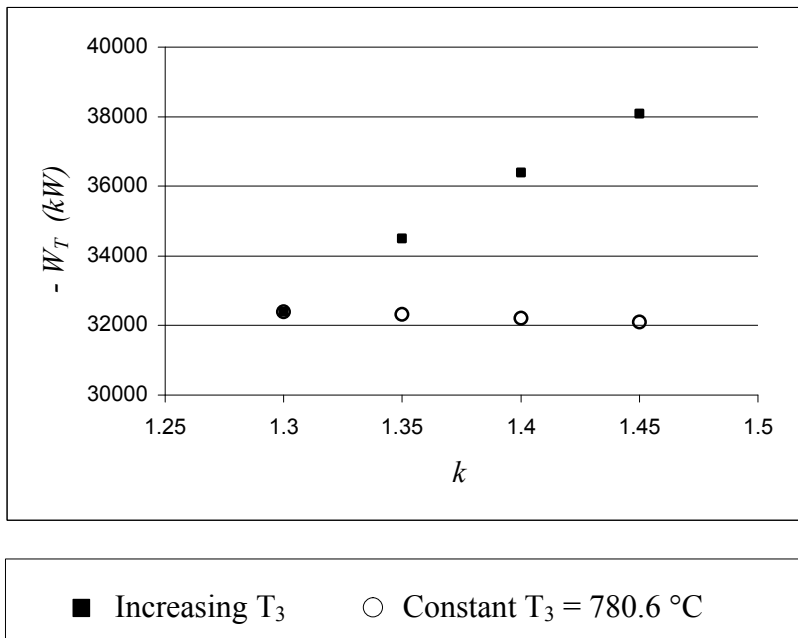

Figure 3.37 W_T versus k for constant-conversion system.

Adiabatic reaction system with an equilibrium-limited reaction

An analysis was done for the following exothermic reaction:

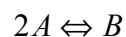

Table 3.7 shows the values that were assumed for the known parameters. Figure 3.38 shows how T_3 increases with k . Associated with the increase in T_3 , is a decrease in x_A , as shown in Figure 3.39. Figure 3.40 and 3.41 show how W_{PG} (in kW) and η_{PG} increase with k , however, W_{PG}/n_R (kJ/kmol) decreases, due to increased recycle, as shown in Figure 3.42. Note that the

same phenomenon of a maximum W_{PG} , as seen for the same system on changing P_{ratio} , is not seen here.

Table 3.7 Data used to illustrate effect of specific heat ratio on adiabatic reaction system with equilibrium-limited reaction

Parameter	Unit	Value
P_{ratio}	-	10
ΔH_R	kJ/kmol A	-20 000
n_{AF}	kmol/s	2.07
T_F	°C	40
P_3	bar	213
C	-	-11.8

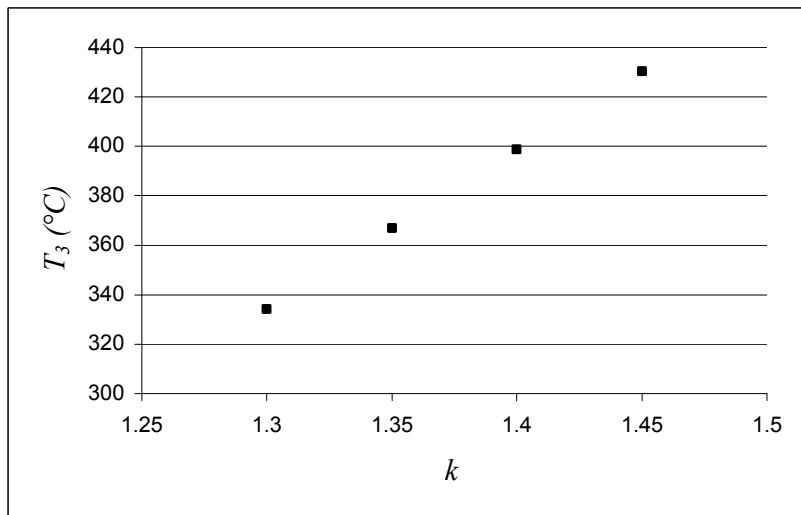

Figure 3.38 T_3 versus k for adiabatic reaction system with equilibrium-limited reaction.

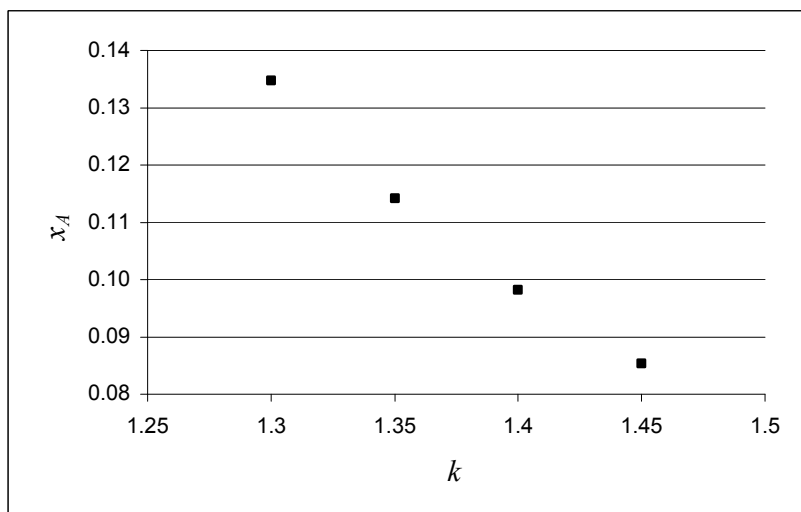

Figure 3.39 x_A versus k for adiabatic reaction system with equilibrium-limited reaction.

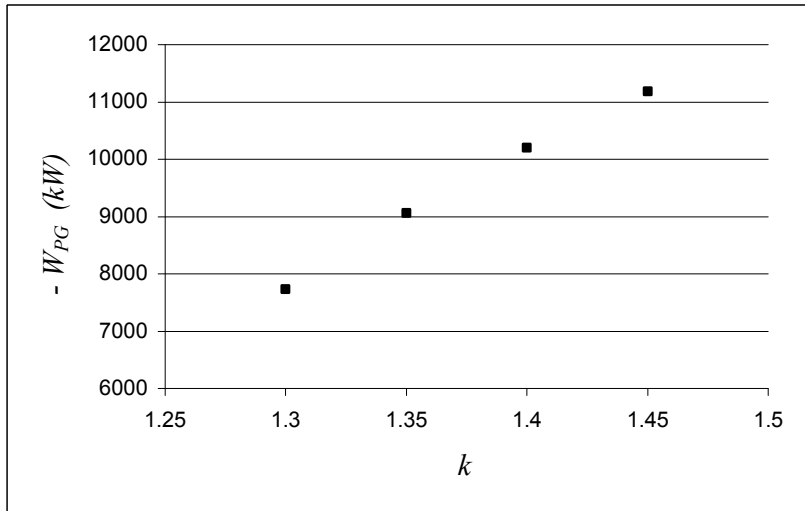

Figure 3.40 W_{PG} versus k for adiabatic reaction system with equilibrium-limited reaction.

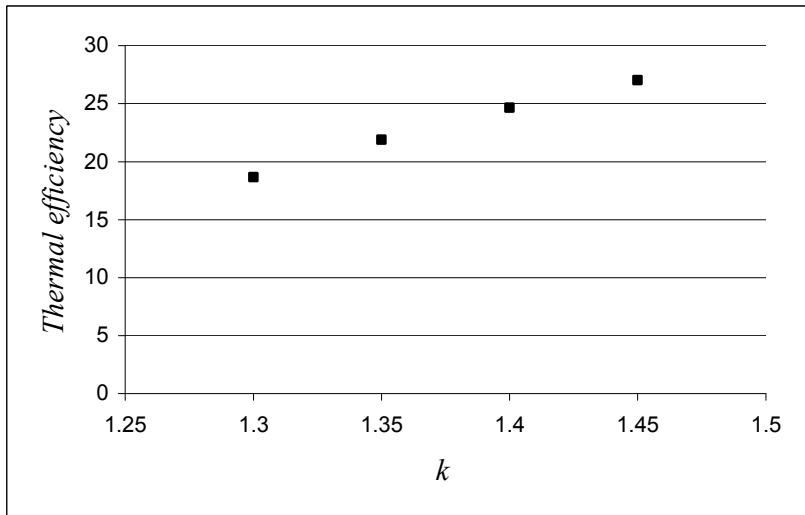

Figure 3.41 Thermal efficiency versus k for adiabatic reaction system with equilibrium-limited reaction.

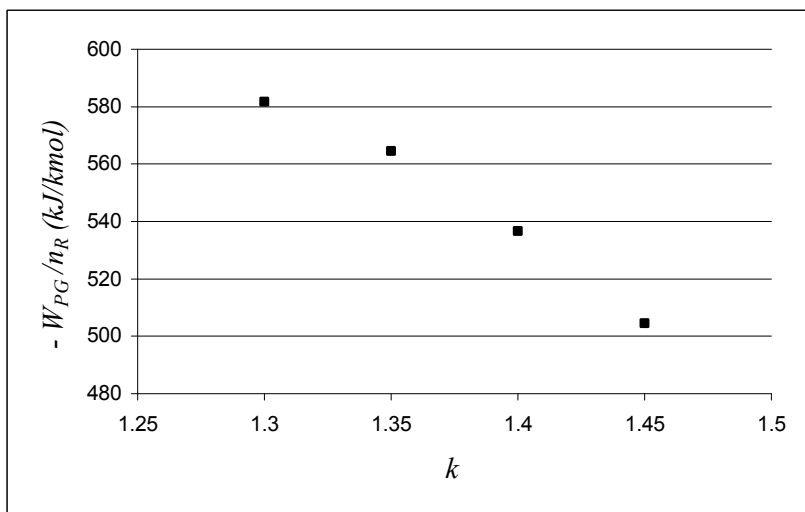

Figure 3.42 W_{PG}/n_R versus k for adiabatic reaction system equilibrium-limited reaction.

3.5.7 Isentropic efficiency

Isentropic efficiency is a characteristic of the compression or expansion machinery chosen for the design. Isentropic efficiency gives an indication of how the real work needed for compression and obtained from expansion deviates from the isentropic work. The isentropic work is for an adiabatic and reversible process, which means that the machine is isolated from the environment to prevent any heat loss and that there are also no friction losses.

3.5.8 Operation window

The previous investigations showed that it is very difficult to put an exact operation window on a reactor coupled to an expander. However, some indications may be given.

Heat of reaction, conversion and thermal efficiency

The heat of reaction and conversion determines the heat transferred to the process gas, Q_{PG} . Thermal efficiency will determine what portion of this heat is converted to work. It is therefore impossible to put individual limits on the heat of reaction, conversion and thermal efficiency, Q_{PG} should be estimated for each case. The work that may be obtained from the system should at least be such that it makes economic sense to produce power using the process gas. A rough first estimate can be done to determine whether it is worth it to proceed further with the design.

Expander inlet temperature / reaction temperature

From practical considerations it is known that the maximum possible turbine inlet temperature is 870 °C (Dresser-Rand, 2001). At higher temperatures blade cooling will have to be used. Modern gas turbines operate at temperatures up to 1500 °C.

Pressure ratio and reaction pressure

Pressure ratio will be determined by the reactor pressure and the minimum required pressure for downstream product processing or separation. The pressure ratio for single stage expansion typically varies from 5 to 15. Therefore, the reaction pressure should be at least 5 bar.

Expander size

Turbine expander sizes vary from 75 kW up to 130 MW (Bloch, 2001a; Dresser-Rand, 2001).

Isentropic efficiency

Typical isentropic efficiencies range from 84 to 86% (Bloch, 2001b).

3.6 Process design criteria for turbine expander integration

The required characteristics of processes that have the potential to be successfully integrated with a turbine expander are briefly discussed. These characteristics are also referred to as *process design criteria*. Note that the chemical processes chosen for the case studies presented in the next chapters in this thesis differs quite significantly in terms of reactor operation, reaction characteristics and separation techniques. In all the case studies successful integration of a turbine expander was however achieved. In Chapter 9 the characteristics of the reactor and reactions of the various cases are compared in Table 9.1 (excluding the case on synthesis gas expansion). Table 9.2 lists information on the various processes against the impact factors. This will give the reader a short overview of the process differences. With this information in mind the following are the required characteristics for turbine expander integration:

Heat source

The reaction should be exothermic to allow for heat to be available to the process gas power cycle, Q_{PG} . Note that the heat of reaction, conversion as well as reaction temperature varies considerably for the different cases in Table 9.1. As mentioned in section 3.5.8, it is impossible to put individual limits on the heat of reaction and conversion, Q_{PG} should be estimated for each case.

Reactor operation

An adiabatic reactor is the most favourable case. Otherwise there should be a temperature increase across the reactor to allow for at least a portion of the reaction heat to be absorbed by the process gas. Q_{PG} should be estimated to determine if enough power may be obtained from the process gas cycle.

Phase of reaction products

Products that leave the reactor should be in the gas phase to enable expansion in a turbine expander.

Reaction pressure

The pressure in the reactor should be at least 5 bar to enable a suitable pressure ratio across the turbine expander. Increasing the reaction pressure can be considered, this was done in the ethylene oxide case study and is discussed in Chapter 7, section 7.2.

Reaction temperature

The higher the temperature of the reaction and reaction products, the more beneficial it is for power production. There will probably also be a greater driving force for heat transfer to cool the reaction products via for example, steam generation. The potential for improving the system is therefore greater. In this regard the production of synthesis gas presents the best opportunity for integration of a turbine expander since the temperatures are substantially higher than those of the other case studies (900-1 400°C).

3.7 Conclusions

This chapter considered the combination of chemical reaction systems with power cycles to create process gas power cycles for the simultaneous production of power and chemicals. The approach and methodology presented here were developed while conducting a number of real case studies on different chemical processes. These case studies are presented in the next chapters. Note that no reference is made to the flow sheet design methodology in the earlier case studies on phthalic anhydride, methanol and ammonia. In the later cases studies on ethylene oxide and synthesis gas production the novel approach to combine a chemical reaction system and power cycle is applied and presented.

The novel approach involves three important aspects, namely the realisation of the analogy between a chemical reaction system with expansion turbine and a conventional power generation cycle. Secondly, synergistic effects are identified and used to improve the flow sheet. Thirdly, appropriate system boundaries are defined to consider systems instead of single unit operations. In this regard two approaches to defining system boundaries for comparison of systems are presented. In the first approach only the section of the flow sheet where differences exist between two processes can be enclosed by a system boundary. In another approach the comparison of systems is done using the concept of *heat engines*. All unit operations needed to complete a power cycle are included into the system boundaries. The second approach is considered best in comparing these kinds of systems.

A methodology was presented to lend structure to the development and analysis of the flow sheets for the mentioned systems. The method involves the consideration of various factors that were identified to impact on the flow sheet design. These factors include e.g. single pass or recycle operation, reaction conditions, reactor operation, conditions for separation of product and the physical properties of the process gas. In Chapter 9 of this thesis the application of the methodology is illustrated with reference to the first four case studies (excluding the synthesis gas production case). A short overview and summary of the results of the cases are given and differences between the cases are also stressed.

To aid in the analysis of the integrated flow sheets, simplified mathematical models were developed for two typical process gas power cycles, namely an adiabatic reactor-separator system with equilibrium-limited reaction and one with reaction kinetics. The following flow sheet parameters were identified as most important in the design of these systems: heat input and thermal efficiency, expander and compressor inlet temperatures, gas flow rate and composition, pressure ratio, volume change during chemical reaction, specific heat ratio of the process gas and the isentropic efficiency of the compression and expansion machines. The pressure ratio, volume change during chemical reaction and the specific heat ratio of the process gas were investigated using the developed mathematical models for an adiabatic equilibrium-limited reaction and a reaction with reaction kinetics. Comparisons were made to

a constant-conversion model, which resembles a conventional gas power cycle. The following conclusions were drawn from these investigations:

- *Variation of pressure ratio*

For a constant-conversion case T_3 , thermal efficiency and W_{PG} increase with pressure ratio. The relation is however not linear. For the model with equilibrium-limited reaction T_3 increases with pressure ratio. Associated with the increase in T_3 , is a decrease in conversion. W_{PG} has a maximum value at a certain pressure ratio, this is quite different to what happens in the constant-conversion model. A high conversion in the reactor is not necessarily the best in terms of power production. The point of maximum W_{PG} coincides with the maximum efficiency, however, maximum efficiency coincides with a fairly large recycle flow rate and large expensive equipment may be needed to obtain this efficiency. It is therefore desirable to operate at a pressure ratio that yields the most work per mole flow of the recycle stream. Results for the model with reaction kinetics were similar to that obtained for the model with an equilibrium-limited reaction, except for T_3 which *decreased* with an increase in pressure ratio. Maximum values for W_{PG} and thermal efficiency were not obtained although the values do start to level off with increasing pressure ratio.

- *Effect of volume change during reaction*

An investigation was done using the adiabatic reaction model with reaction kinetics. Stoichiometry was changed for a simple reaction and it was found that this has a significant effect on the power production.

- *Effect of change in specific heat ratio*

For a constant conversion case more work, W_{PG} in kJ/kmol, is obtained at higher specific heat ratios. However, the real reason for this is that the temperature at the expander inlet also increases with increasing specific heat ratio. For constant expander and compressor inlet temperatures, both compression and expansion benefits from lower specific heat ratios. For the equilibrium-limited reaction model T_3 also increases with specific heat ratio resulting in a decrease in conversion and decrease in the specific work obtained from the system, W_{PG} in kJ/kmol. The opposite effect is therefore obtained for the equilibrium-limited reaction model compared to a system that resembles a conventional gas power cycle.

3.8 References

Atkins PW, *Physical Chemistry*, fourth ed., Oxford University Press, Oxford, 1990.

Bloch HP, "Consider turbo-expanders" (Editorial Comment), *Hydrocarbon Processing*, vol. 80, no. 1, p.1, 2001a.

Dijkema GPJ, Luteijn CP, Weijnen MPC, “Design of trigeneration systems”, *Chemical Engineering Communications*, vol. 168, pp. 111-125, 1998.

Dresser-Rand Products Website, “FCC Power Recovery Expanders”,
<http://www.dresserand.com/turbo/eq/expand.asp>, accessed November 2001.

Greeff IL, Perold J, Visser JA, Ptasinski KJ and Janssen FJJG, “Using turbine expanders to recover exothermic reaction heat – flow sheet development for typical chemical processes”, *Proceedings of ECOS2002*, vol. 2, pp. 1119-1127, July 3-5, Berlin, Germany, 2002.

Kyle BG, *Chemical and Process Thermodynamics*, second ed., Prentice Hall, New Jersey, 1992.

Moran MJ, Shapiro HN, *Fundamentals of Engineering Thermodynamics*, third ed., John Wiley & Sons Inc., New York, 1995.

Smith JM, *Chemical Engineering Kinetics*, third ed., McGraw-Hill International, 1981.

Chapter 4

Using turbine expanders to recover exothermic reaction heat – a case study on a phthalic anhydride process*

Phthalic anhydride (PA) is produced from alkyl-substituted- or multinuclear aromatic compounds such as o-xylene or naphthalene by partial oxidation. With reaction enthalpies as high as -1 793 kJ/mol naphthalene reacted, there are many opportunities for energy recovery making these systems attractive for process integration research.

The production of PA from naphthalene is used to investigate two energy recovery schemes. The first is a Rankine cycle that uses steam, raised during the cooling of the reactor, to produce power. The second also includes a turbine expander at the reactor exit. It expands hot reactor product gases to deliver additional power and reduces the pressure of the reactor product before it enters the separation section.

Simulation results showed that, under certain operating conditions, the steam cycle alone could not supply the feed compression power requirement. However, when a turbine expander is included in the process, all of the power requirements can be fulfilled and excess power can be exported for use elsewhere.

Unlike power generation from fossil fuels, no carbon dioxide is emitted to the atmosphere when an expansion turbine is used. Savings in CO₂ emissions between 4.0 and 6.3 ton/hour are estimated for this unit.

An exergy analysis showed that the thermodynamical losses of the process with the second energy recovery scheme are 4.5% lower than that of the first. The reason being that power can be recovered when expansion takes place in a turbine instead of an isenthalpic expansion valve.

** Published paper: Perold J, Greeff IL, Ptasinski KJ, Janssen FJJG, "Using a turbine expander to recover exothermic reaction heat – a case study on a phthalic anhydride process", South African Journal of Chemical Engineering, vol. 13, pp. 1-14, 2001.*

Symbols used

\dot{E}	Exergy flow (kW)
\dot{i}	Irreversibility rate (kW)
\dot{W}	Exergy associated with work transfer (kW)
Q	Heat (kW)

Greek symbols

h	Efficiency (-)
-----	----------------

Superscripts

Q	Exergy associated with heat transfer
---	--------------------------------------

Subscripts

DOP	Degree of perfection
M	Material
1	Heat removed from reactor
2	Heat from reactor product cooling

Flow sheet abbreviations

PA	Phthalic anhydride
MA	Maleic anhydride
PC	Partial condenser
SC	Switch condenser
DC	Distillation Column

4.1 Introduction

Many exothermic reactions are carried out in the chemical industry. Energy recovery schemes are used to reclaim part of the reaction heat and thereby reduce operating costs. These schemes often include heat transfer from the hot reactor product gas to another medium by heat exchange. Although processes with energy recovery schemes have higher energy efficiencies than processes without them, there are still large thermodynamical losses associated with the temperature driving forces employed in heat exchangers (Kotas, 1995).

Janssen et al. (1997) patented a concept for reaction heat recovery that does not include heat transfer. In their concept, the reaction products, from an exothermic reaction conducted at elevated pressure, are expanded in a turbine whereupon the reaction heat is converted to power.

The integration of such an expansion turbine in a chemical process does however pose new challenges. At times, it requires flow sheet modifications or changes in the operating conditions of the process units. The role of utilities (reactor cooling liquid, electricity and steam etc.) also changes, with the focus on energy recovery and withdrawal now falling on the chemical process fluid itself.

Recently Greeff, Ptasinski and Janssen analysed an ammonia process that includes an expansion turbine (Greeff et al., 2001). Their results showed that, even without process optimisation, enough energy could be recovered from the expansion turbine to drive the compressor and supply part of the required refrigeration work for separation.

It was therefore decided to extend the concept further by evaluating the feasibility of expansion turbine integration with a phthalic anhydride production process. The aim of this paper is to investigate two energy recovery schemes for the production of phthalic anhydride from naphthalene. The first is a Rankine cycle that uses steam to produce power. The second scheme includes a turbine expander at the reactor exit in addition to the steam cycle. The turbine expander supplements power production by the expansion of hot reactor product gases.

Aspen Plus simulation models of a phthalic anhydride process, with the two mentioned energy recovery schemes, are developed from literature data. Energy and exergy analysis parameters are used to compare the simulation results. Exercom, an add-on package to Aspen Plus, is used to calculate the exergy parameters in this investigation. An estimate for the saving in carbon dioxide emission is also calculated as no carbon dioxide is emitted to the atmosphere when the expansion turbine is used for power generation.

4.2 Literature survey

Integration of turbine expanders in chemical processes

Several patents have already been issued on the integration of expansion turbines in chemical processes for energy recovery. Depending on the position of the turbine expander in the process, these patents can be classified in two groups. The turbine is either placed at a point where a suitable pressure ratio exists or, in the case of an exothermic reaction conducted at an elevated pressure, it can be placed directly behind the reactor.

Patents belonging to the first group include a patent granted to Horton (1967). Horton showed how high temperature reaction heat, from a reaction conducted at low pressure, could be transferred to a high-pressure gas stream before the latter is expanded. Barber et al. (1981) patented a process that combines a chemical plant with a semi-closed Brayton cycle. Moderate temperature heat is transferred from the reaction product to the working fluid of the Brayton cycle and, in return, the gas turbine supplies a part of the process' compression power. Linnhoff et al. (1993) patented a concept that increases the amount of power obtainable from an exothermic reaction conducted at high pressure. They suggested that a feed stream, exceeding the full load capacity of the reactor system be compressed. The excess

high-pressure feed gas bypasses the reactor, but is heated with heat removed from the reactor. It is finally mixed and expanded with the reactor products to generate power.

In all three of the mentioned patents, and others belonging to the first group, heat transfer is involved from the hot reactor product to the fluid that undergoes expansion. Large temperature driving forces are used to transfer the heat economically, but it comes at a price. The thermodynamical losses associated with heat transfer increase with increases in the temperature driving force (Kotas, 1995). One alternative to increase the efficiency of reaction heat recovery would be to avoid heat transfer altogether.

When a turbine expander is placed directly behind the reactor, as is the case with patents belonging to the second group, energy recovery can occur without heat transfer. Rao (1991) suggested that an exothermic reactor and a turbine expander be placed before a gas turbine or fuel cell. Feed gases are allowed to react exothermically to produce a gaseous product that can be used for power generation in the downstream gas turbine or fuel cell. The heat given off during the said reaction is recovered as power in the intermediate turbine expander. Janssen et al. (1997) placed a turbine expander directly behind a reactor. The hot reaction product is expanded and the physical energy, stored in the hot product, is converted to power. Ideally the reactor should be under adiabatic operation so that all the reaction heat may be stored as physical energy in the reaction mixture. This would increase the amount of energy available for recovery in the turbine expander.

Exergy analysis

Exergy analysis is a relatively new technique that combines the First and Second laws of Thermodynamics. It enables process engineers to point out the decline in energy quality in energy intensive processes. This leads to a better understanding of the influence of the thermodynamic phenomena on a process. Exergy analysis is thoroughly documented in the textbooks of Kotas (1995) and Szargut et al. (1988).

For a steady state flow system such as a chemical process the exergy balance is (Kotas, 1995: 63):

$$\sum_{in} \dot{E}_m + \dot{E}^Q + \dot{W} = \sum_{out} \dot{E}_m + \dot{I} \quad \dots 4.1$$

The first four terms refer to exergy associated with the three possible types of energy transfer over the system boundaries:

\dot{E}_m exergy associated with material flow

\dot{E}^Q exergy associated with heat transfer

\dot{W} exergy associated with work transfer

The fifth term, \dot{I} , is the irreversibility rate or exergy loss due to the thermodynamic imperfection of the process under consideration. Calculation procedures for each of these terms are described in Kotas (1995: 34-49). The exergy balance is different from the energy balance in that it is based on a law of degradation rather than a law of conservation (Kotas, 1995: 32).

Exergy calculations depend heavily on thermodynamic data and hence an analysis of even a simple process can become too cumbersome to perform by hand. Special software packages, such as Exercom, have therefore been developed to handle the calculation burden (Hinderink et al., 1996). This program is available as an add-on for use with popular flow sheet simulators.

Results of exergy calculations can be reported in several ways. The most commonly used, include second law efficiencies such as the degree of perfection (Szargut et al., 1988: 19):

$$h_{\text{DOP}} = \frac{\text{Exergy of useful products}}{\text{Exergy input}} \quad \dots 4.2$$

Exergy efficiencies should however only be used to compare similar processes operating under similar conditions. Comparison of dissimilar components should be based on the irreversibility rate in each unit (Tsatsaronis, 1999).

Phthalic anhydride production

Phthalic anhydride is produced by the catalytic partial oxidation of naphthalene according to the reaction (Lorz et al., 2001):



The reaction is extremely exothermic with a reaction heat of -1 793 kJ/mol naphthalene reacted at 25°C. Two reactor configurations are used industrially: multi-tubular fixed bed and fluidised bed reactors. Fluidised bed reactors have higher operating pressures, 3.4 to 35 bar (Ryder et al., 1974), which is more beneficial for expansion and is considered further. A

process flow sheet for a plant producing phthalic anhydride via the catalytic oxidation of naphthalene is shown in Figure 4.1.

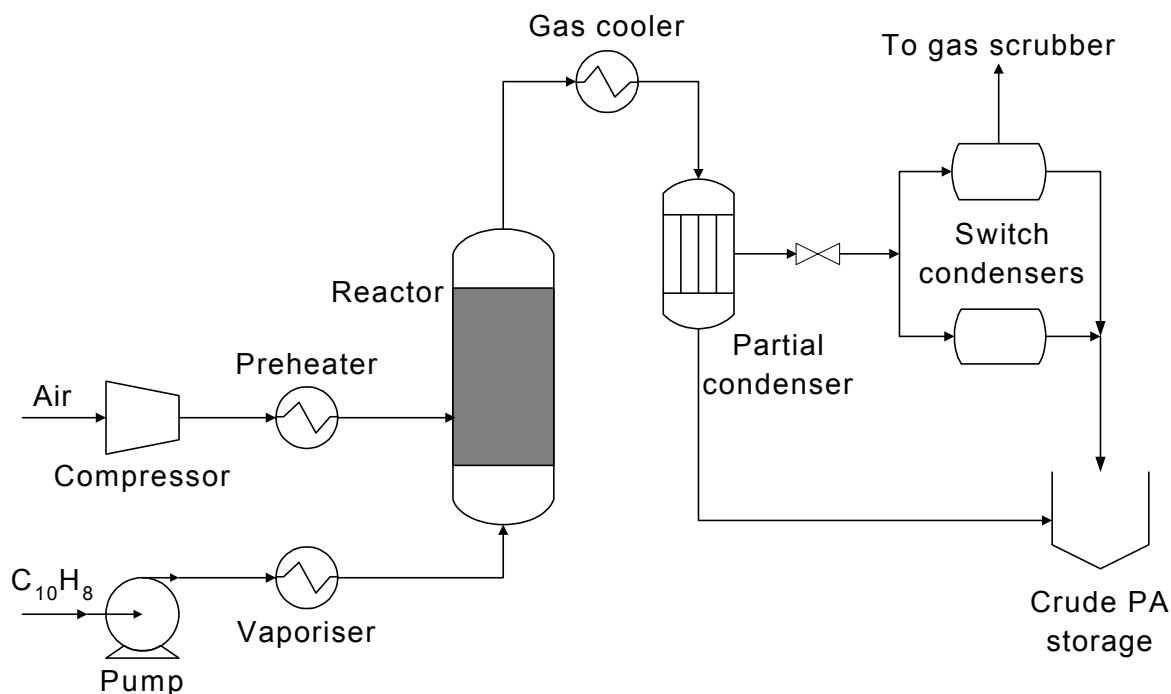

Figure 4.1 Flow sheet for phthalic anhydride production using a fluidised bed reactor (Ryder et al., 1974).

Air and naphthalene are brought to the reactor pressure by a compressor and pump respectively. The air is then preheated and naphthalene vaporised before entering the reactor (Ryder et al., 1974). The fluidised reactor is maintained at a temperature of 320-400°C and a pressure of 3.4 to 35 bar. Yields as high as 90 kg PA/100 kg naphthalene can be achieved (Ryder et al., 1974). The remaining naphthalene reacts via two competing reactions:

the formation of maleic anhydride (MA)



and complete combustion (Lorz et al., 2001)



Heat liberated by the reaction is removed by the direct generation of steam. Steam pressures in the range of 7 to 28 bar (Kunii & Levenspiel, 1991: 28) are typical. Recent advances in PA

production technology include the expansion of the steam in a steam turbine for power generation. The power is used to drive the air compressor (Lorz et al., 2001).

From the reactor, the reaction product proceeds to the separation section where roughly half of the phthalic anhydride can be removed from the reaction mixture by partial condensation (Ryder et al., 1974). The remainder is recovered in switch condensers where the reaction mixture is cooled until the phthalic anhydride solidifies. The combustion products are subsequently removed from the unit and scrubbed with water before being vented to the atmosphere (Ryder et al., 1974). The phthalic anhydride is melted and it flows to a storage tank where it awaits final purification via distillation.

4.3 Process modelling

Process flow sheet

Figure 4.2 shows the flow sheet of the phthalic anhydride process as simulated in Aspen Plus. The process units of the two energy recovery schemes are also shown and are denoted as belonging to Case A and Case B respectively.

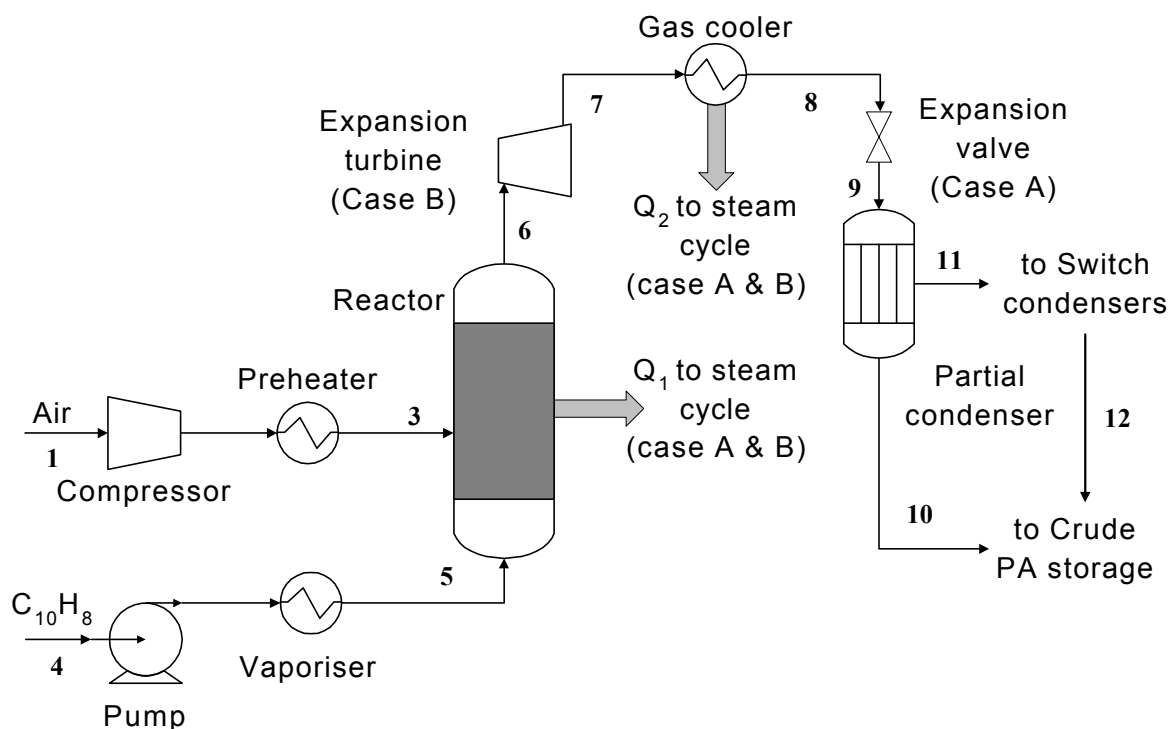

Figure 4.2 Flow sheet of the phthalic anhydride process with the energy recovery schemes as simulated in Aspen Plus.

In Case A, the steam cycle is responsible for energy recovery and the pressure drop to the partial condenser pressure occurs in the expansion valve. In Case B, an expansion turbine is inserted directly behind the reactor. It recovers energy and reduces the pressure.

Assumptions and constraints

Two property methods are used in the simulation models. The Soave-Redlich-Kwong method is used for the hydrocarbon processing section whilst the STEAMNBS method is used for the steam cycle. All process units are well insulated. Pressure drop in reactor, heat exchangers, mixers etc. are assumed to be negligible compared to the pressure changes in the turbines, compressors and expansion valves.

The air compressor is assumed to consist of two stages with intermediate cooling. Both stages operate with isentropic efficiencies of 72% and intercooling to 25°C is assumed. No reaction kinetics are used as there is still disagreement on the naphthalene reaction order (Wainwright & Foster, 1979). A stoichiometric reactor model is used instead. The conversion data, shown in Table 4.1, is used in the simulation model.

Table 4.1 Reaction conversion specifications for the reactor model.

Reaction	Conversion
$C_{10}H_8 + 4.5O_2 \rightarrow C_8H_4O_3 + 2CO_2 + 2H_2O$	78%
$C_{10}H_8 + 6O_2 \rightarrow 2C_4H_2O_3 + 2CO_2 + 2H_2O$	8%
$C_{10}H_8 + 12O_2 \rightarrow 10CO_2 + 4H_2O$	11%
$C_{10}H_8 + 7O_2 \rightarrow 10CO + 4H_2O$	3%

Simulations are carried out with the reactor conditions set at combinations of three temperatures and pressure levels namely 320, 365 and 400°C and 8, 12 and 16 bar. Reactant flow rates are chosen to achieve a phthalic anhydride production rate of 11 ton/hour.

The conditions of the feed entering the partial condenser are fixed at 160°C and 1.8 bar. At these conditions 51% of the phthalic anhydride can be recovered in liquid form. This is in close agreement with literature (Miserlis, 1984). By fixing these conditions, the temperature and pressure drop for the upstream energy recovery operations are also bounded.

Case A: Energy recovery by a steam cycle

The heat removed from the reactor (Q_1) and the heat released upon cooling the reactor product (Q_2) are used to generate power in a Rankine-type steam cycle such as the one shown in Figure 4.3. The reactor product is used to heat cold water whilst the reactor heat is used to

vaporise and superheat the hot water. Cooling water at 15°C and ambient pressure is used to remove heat from the condenser. Other specifications for the steam cycle calculations are shown in Table 4.2.

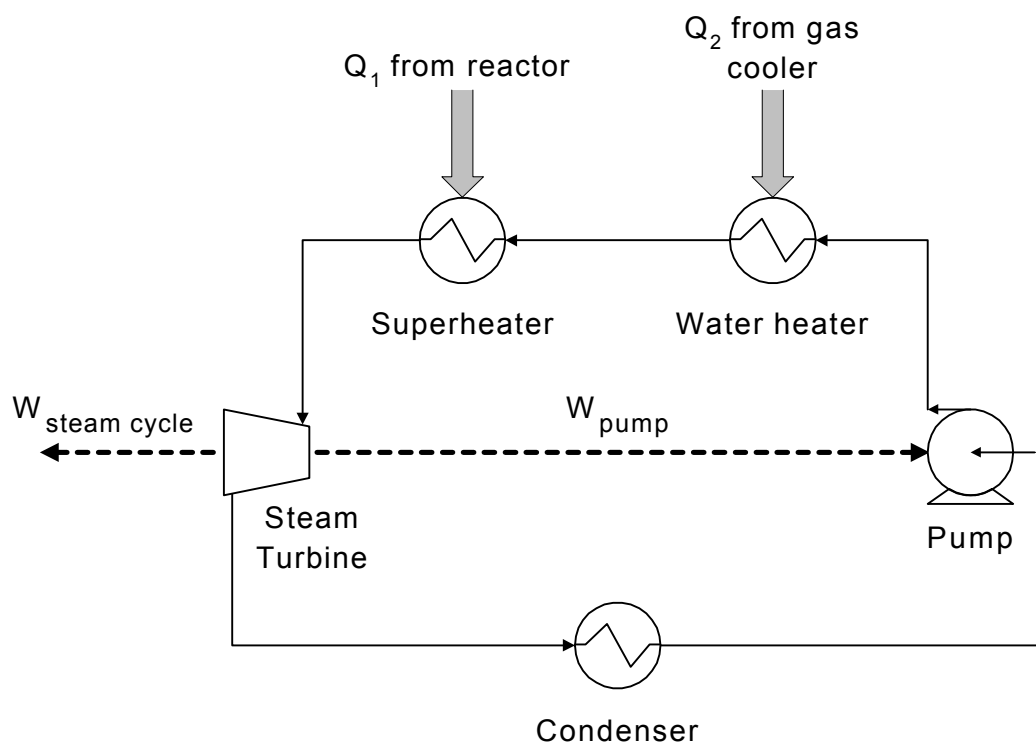

Figure 4.3 Steam cycle used in simulation models.

Table 4.2 Steam cycle specifications.

Parameter	Value	Units
Temperature driving force for vaporiser/superheater	20 ^a -35	°C
Temperature driving force for condenser	20	°C
Steam turbine inlet pressure	28	bar
Steam turbine isentropic efficiency	75	%
Steam turbine outlet pressure	0.15-0.2 ^a	bar
Maximum liquid fraction at turbine outlet ^b	0.1	-
Degrees of subcooling in condenser	5	°C
Pump efficiency	100	%

^a Specification when reaction temperature is 320°C

^b Limit commonly applied in practice (Winnick, 1997: 177)

Three numerical solvers are used to model the Rankine cycle in Aspen Plus. The first ensures that the temperature driving force specification for the superheater is met whilst the second controls the liquid fraction at the steam turbine outlet. The third routine calculates the cooling

water flow rate required to remove the low temperature heat from the condenser. The flow rate of the steam in the cycle is optimised for maximum power generation.

After the reactor product has been cooled, its pressure is reduced to 1.8 bar in an isenthalpic expansion valve. This is the pressure at which the partial condenser operates.

Case B: Energy recovery by a steam cycle and a turbine expander

Case B includes an expansion turbine for energy recovery in addition to the steam cycle. The turbine operates with an isentropic efficiency of 72%. Unlike the steam turbine where a 10% liquid fraction is allowed, no liquid is allowed to form in the expansion turbine. Ideally the outlet pressure of the expansion turbine should coincide with the operating pressure of the partial condenser, thereby eliminating the expansion valve. However, in three simulations where liquid presence was predicted, the turbine's outlet pressure was increased until this was no longer the case. The particular cases where condensation occurred, as well as the adjusted outlet pressure are given in Table 4.3. The remainder of the pressure drop to 1.8 bar occurred via an expansion valve similar to the one used in Case A.

Table 4.3 Adjusted outlet pressure for cases where condensation occurred.

Reactor conditions		Expansion turbine
Temperature	Pressure	outlet pressure
320°C	12 bar	2.5 bar
320°C	16 bar	3.9 bar
365°C	16 bar	1.9 bar

4.4 Results and discussion

Net power generation

The power consumed by the feed compressor and pump are summarised alongside the power generated from the steam cycle and expansion turbine in Table 4.4. According to the sign convention used, power consumption is positive and power generation is negative.

Table 4.4 shows that there are sets of operating conditions for which the steam cycle in Case A cannot supply all of the power required for compression and power has to be imported from an external source. In Case B, there is a net power production for all the conditions

investigated and power can therefore be exported. The results also show that the net power production increases with an increase in reaction temperature. This is expected as both the steam cycle and expansion turbine deliver more power at higher reaction temperatures.

Table 4.4 Comparison of net power generated.

	Case A + B	Case A	Case B				Net power increase - case B over case A
Reaction temp. (°C)	Feed pump and compressor power (kW)	Steam cycle power (kW)	Net power (kW)	Steam cycle power (kW)	Expansion turbine power (kW)	Expansion turbine contribution to total power (%)	Net power (kW)
Reaction pressure = 8 bar							
320	12 176	-14 046	-1 870	-12 646	-6 297	33	-6 767
365	12 176	-14 692	-2 516	-13 098	-6 757	34	-7 679
400	12 176	-14 874	-2 698	-13 164	-7 141	35	-8 129
Reaction pressure = 12 bar							
320	14 679	-14 106	573	-12 613	-6 592	34	-4 526
365	14 679	-14 716	-37	-12 790	-8 253	39	-6 364
400	14 679	-14 928	-250	-12 856	-8 686	40	-6 862
Reaction pressure = 16 bar							
320	16 387	-14 115	2 272	-12 776	-6 038	32	-2 427
365	16 387	-14 751	1 636	-12 622	-9 078	42	-5 313
400	16 387	-14 964	1 423	-12 645	-9 731	43	-5 990

The best case, with the highest net power increase on integration of a turbine expander, is the case with reactor conditions at 400 °C and 16 bar. Table 4.5 shows the mass and energy balance results for case A and B for these reactor conditions.

Savings on carbon dioxide emissions

The carbon dioxide emissions associated with power generation from fossil fuels are also not present when an expansion turbine is used for power generation. By using the values for the net power increase in the last column of Table 4.4, and the fact that 0.85 kg CO₂ is emitted per kilowatt-hour electricity generated from coal (Eskom, 2001: 56), the saving in CO₂ emission is estimated to be between 4.0 and 6.3 ton/hour.

Table 4.5 Mass and energy balance results (stream numbers correspond to Figure 4.2)

Stream		Reaction conditions: 400 °C and 16 bar							
		Case A				Case B			
No.	Name	n kmol/h	m ton/h	P bar	T °C	n kmol/h	m ton/h	P bar	T °C
1	Air feed	5 000	144.3	1	25	5 000	144.3	1	25
2 ^a	Air to 2 nd compressor stage	5 000	144.3	5	25	5 000	144.3	5	25
3	Air to reactor	5 000	144.2	16	187	5 000	144.3	16	187
4	Naphthalene feed	100	12.8	1	25	100	12.8	1	25
5	Naphthalene to reactor	100	12.8	16	387	100	12.8	16	387
6	Reaction product	5 082	157.1	16	400	5 082	157.1	16	400
7	Turbine outlet	-	-	-	-	5 082	157.1	1.8	199
8	Expansion valve inlet	5 082	157.1	16	176	5 082	157.1	1.8	160
9	PC inlet	5 082	157.1	1.8	160	5 082	157.1	1.8	160
10	From PC to storage	41	6.0	1.8	160	41	6.0	1.8	160
11	From PC to SC	5 041	151.1	1.8	160	5 041	151.1	1.8	160
12	From SC to storage	53	7.1	1.4	131	53	7.1	1.4	131
13 ^a	From storage to DC	94	13.1	1.4	144	94	13.1	1.4	144
14 ^a	MA	19	2.0	0.1	142	19	2.0	0.1	142
15 ^a	PA	75	11.1	0.25	233	75	11.1	0.25	233

Parameter	Work and heat streams (kW)	
$W_{\text{COMPRESSOR}}$	16 375	16 375
W_{PUMP}	12	12
W_{TURBINE}	-	- 9 731
$W_{\text{STEAM CYCLE}}$	-14 964	-12 645
Q_1	-51 986	- 51 986
Q_2	-12 382	- 2 650

^a These streams are not shown in Figure 4.2.

Exergy analysis

An exergy analysis was conducted for both cases at the reactor conditions of 400°C and 16 bar because the contribution of the expansion turbine to the total power is the highest (43%) at these conditions. The boundary conditions shown in Figure 4.4 were used in this analysis as this is the only section where differences exist between the two processes.

The degree of perfection for the subsection under consideration is given by:

$$h_{\text{DOP}} = \frac{E_{\text{partial condenser feed}} + W_{\text{chemoturbine}} + W_{\text{steam turbine}}}{E_{\text{reactor air feed}} + E_{\text{reactor naphthalene feed}} + E_{\text{condenser cooling liquid}} + W_{\text{steam cycle pump}}} \quad \dots 4.6$$

The cooling liquid from the condenser is not included in the numerator of equation 6. With a temperature of only 40°C, it has little use for heat transfer applications and hence it is not considered to be of value.

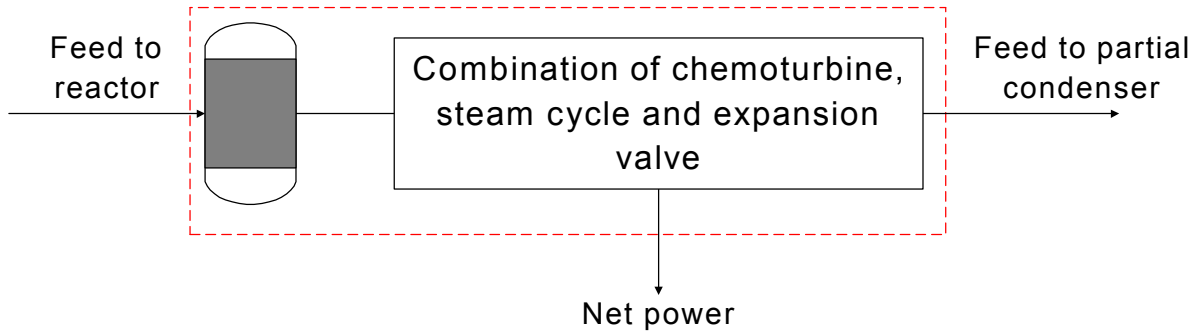

Figure 4.4 System boundaries for exergy analysis

Using equation 6, the degree of perfection was calculated as 58.7% and 63.2% for Case A and B respectively. The irreversibility rates of each of the unit operations, within the boundaries of Figure 4.4, are compared to determine each unit's contribution to the improvement in the degree of perfection. The results are shown in Figure 4.5.

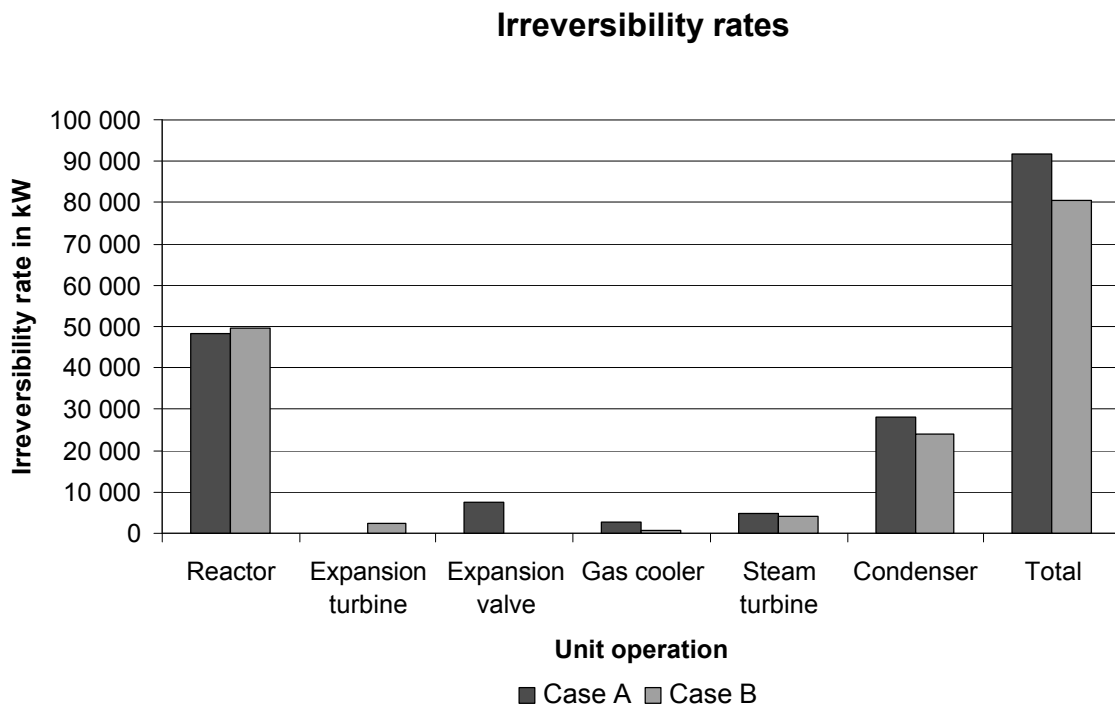

Figure 4.5 Comparison of irreversibility rates per unit operation.

One advantage of exergy analysis over First Law analysis methods comes to light when the irreversibilities of the units responsible for the pressure reduction are compared. An energy balance over the expansion valve will show it to be 100% efficient, but one can now see that losses do occur in this unit. The irreversibility rate is significantly smaller when the pressure is reduced in an expansion turbine as in Case B, because a valuable product, power, is also obtained.

The irreversibility rate in the reactor is slightly higher for Case B. This is due to the lower temperature of the boiler feed water. The boiler feed water temperature is lower for Case B because a temperature decrease occurs in the expansion turbine leaving a lower temperature to heat boiler feed water. In Case A, boiler feed water is heated with heat at the reactor temperature.

The lower temperature of the turbine exhaust gas has a positive aspect too. The irreversibility rate of the gas cooler of Case B is smaller than that of Case A because the temperature difference between the turbine exhaust gas and the cold water is smaller. This means that a smaller amount of exergy is lost in the heat transfer process.

The steam turbine and condenser also have lower irreversibility rates in Case B. This is attributed to the lower steam cycle flow rate used in Case B. The effect is more prominent for the condenser because the amount of low-grade heat to be discarded from the unit is significantly smaller.

Two unit operations have particularly high irreversibility rates: the reactor and the steam cycle's condenser. If the process were to be improved further, it would be best to focus on these units. One should however proceed with care when improving individual units as a reduction in the irreversibility rate of one unit can be offset by an increase in the irreversibility rate of another (Tsatsaronis, 1999). In the current study the irreversibility rate of the expansion process was decreased but it led to an increase in the irreversibility rate of the reactor. Individual unit operations should only be improved when it leads to an improvement in the degree of perfection of the entire system.

4.5 Conclusions

Two energy recovery schemes, used to recover the reaction heat liberated during the production of phthalic anhydride, were investigated. Both included a steam cycle to recover reaction heat in the form of power. This power is used to drive the feed compressor and pump. In the second process, an expansion turbine was included for additional power production.

Results show that, without the presence of the expansion turbine, there are certain operating conditions where the steam cycle alone cannot supply the full amount of feed compression power. Hence, power has to be imported from an external source. Upon inclusion of the expansion turbine this situation changes and power can even be exported for use elsewhere. Depending on the reactor operating conditions, as much as 8.1 MW can be exported from the process.

Unlike power generation from fossil fuels, no carbon dioxide is emitted to the atmosphere when an expansion turbine is used. Given the amount of power the turbine generates, savings in CO₂ emissions are estimated to be between 4.0 and 6.3 ton/hour.

Exergy analysis was used in this work to examine the influence of thermodynamic phenomena on the process and the two energy recovery schemes. It showed that thermodynamic losses occur in isenthalpic expansion valves even though these units have energy efficiencies of 100%. With exergy analysis these losses can be quantified and the impact of a possible improvement can be assessed with ease. In the current study it was showed that the degree of perfection could be improved by 4.5% when the pressure reduction takes place in an expansion turbine instead of an expansion valve.

Exergy analysis is also a helpful tool to identify units that do not operate in a thermodynamically efficient manner. These units should be looked at more carefully to further improve the process. In the present situation, the reactor and condenser have the largest irreversibility rates and should be considered first. Process units should however only be improved if the improvement leads to an increase the degree of perfection of the overall process.

4.6 References

Eskom (2001) *Eskom's environmental policy*,
<http://www.eskom.co.za/enviroreport01/PDF/report.pdf>, accessed 6 December 2001.

Greeff IL, Ptasinski KJ and Janssen FJJG, "Integration of a turbine expander with an exothermic reactor for the combined production of power and ammonia", in *Proceedings of ECOS 2001*, vol. 1, pp. 369-375, Öztürk, A. and Gögüs, Y.A. (editors), Istanbul, Turkey, 2001.

Hinderink AP, Kerkhof FPJ.M, Lie ABK, De Swaan Arons J and van der Kooi HJ, "Exergy analysis with a flowsheeting simulator-I. Theory; calculating exergies of material streams", *Chemical Engineering Science*, vol. 51, no. 20, pp. 4693-4700, 1996.

Janssen FJJG, Verkooijen AHM and Ploumen PJ, "Synthesis of ethene", *European Patent 0753652*, assigned to Kema NV, The Netherlands, 1997.

Kotas TJ, *The Exergy Method of Thermal Plant Analysis*, Krieger Publishing, Malabar, Florida, US, 1995.

Kunii D and Levenspiel O, *Fluidization Engineering, Second Edition*, Butterworth-Heinemann, Boston, 1991.

Lorz PM, Towae FK, Enke W, Jäckh R and Bhargava N, "Phthalic acid and derivatives - Phthalic Anhydride" in *Ullmann's Encyclopedia of Industrial Chemistry Online*, <http://jws-edck.interscience.wiley.com>, Accessed 26 June 2001.

Miserlis CD, "Process for the production of phthalic anhydride", *US Patent 4435581*, assigned to the Badger Company Inc., US, 1984.

Rao AD, "Reactor expander topping cycle", *US Patent 4999993*, assigned to Fluor Corporation, US, 1991.

Ryder RC, Ryan RE and Klapproth WJ, "Process for the production of phthalic anhydride", *US Patent 3852308*, assigned to Koppers Company, US, 1974.

Szargut J, Morris DR, Steward FR, *Exergy Analysis of Thermal, Chemical and Metallurgical Processes*, Hemisphere Publishing, New York, 1988.

Tsatsaronis G, "Strengths and limitations of exergy analysis", in *Thermodynamic optimization of complex energy systems*, Bejan A and Mamut E (editors), pp. 93-100, 1999.

Wainwright MS and Foster NR, "Catalysts, kinetics and reactor design in phthalic anhydride synthesis", *Catalysis Reviews – Science and Engineering*, vol. 19, no. 2, 211-292, 1979.

Winnick J, *Chemical Engineering Thermodynamics*, John Wiley and Sons, New York, 1997.

Chapter 5

Utilisation of reactor heat in methanol synthesis to reduce compressor duty – application of power cycle principles and simulation tools*

The chemical conversion in a methanol reactor is restricted by equilibrium, therefore the synthesis loop is operated at high pressure and unconverted gas is recycled. Such a synthesis loop consumes large amounts of compression work. In this paper a new flow sheet for methanol synthesis is presented. In this flow sheet the high recycle and operating pressure of the reactor is exploited to produce power. A turbine expander and compressor pair is placed in the recycle stream and utilises the reactor heat at the maximum possible temperature in a process gas power cycle. In conventional systems the reaction heat is often transferred to generate steam to drive steam turbines, but the heat is reduced in quality due to the temperature driving forces in the heat exchange equipment.

Simulation models of the new flow sheet and a conventional flow sheet are created to compare the systems based on energy consumed per kg methanol produced. In the conventional flow sheet the reaction heat is used to generate steam for use in steam turbines. In the new flow sheet a portion of the reaction heat is still transferred to a steam cycle to limit the temperature in the reactor. The remaining heat is used to drive the process gas cycle. The simulation results showed that the new flow sheet consumed overall 24% less energy than the conventional flow sheet.

** Published paper: Greeff IL, Visser JA, Ptasiński KJ and Janssen FJJG, “Utilisation of reactor heat in methanol synthesis to reduce compressor duty – application of power cycle principles and simulation tools”, Applied Thermal Engineering, vol. 22, pp.1549-1558, 2002.*

Nomenclature

m	Mass flow rate (kg/h)
n	Molar flow rate (kmol/s)
P	Pressure (bar)
Q_{HX}	Heat exchanger duty (kW)
Q_{IN}	Heat input to a heat engine/power cycle (kW)
Q_{OUT}	Heat removed from a heat engine/power cycle (kW)
Q_{PG}	Portion of reaction heat absorbed by the process gas (kW)
Q_{R}	Heat of reaction (kW)
Q_{ST}	Portion of reaction heat transferred to generate steam (kW)
T	Temperature ($^{\circ}\text{C}$)
W_{NET}	Net power delivered or required by a system (kW)
W_{NETSP}	Net work delivered or required per kg product (kJ/kg)
W_{ST}	Power delivered by a steam cycle (kW)
W_{PG}	Power delivered using process gas (kW)
W_{TC}	Sum of compression and expansion power (kW)

Flow sheet abbreviations

BFW	Boiler Feed Water
C	Compressor
CW	Cold Water
MP	Medium Pressure
HX	Heat Exchanger
HW	Hot Water
LP	Low Pressure
REAC	Reactor
ST	Steam Turbine
SEP	Separator
T	Turbine

5.1 Introduction

Methanol is produced in amounts of 30-40 million ton per year around the world from CO/CO₂/H₂ (Tsibaki et al., 2001). The conversion in a methanol reactor is restricted by chemical equilibrium. Technology overcomes the problem by using high operating pressure and recycling the unconverted synthesis gas after product separation. Several developments have been reported in literature to improve the efficiency of methanol synthesis. Most of these focus on advanced reactor designs to increase conversion. Examples are the multifunctional reactor with in-situ removal of condensed products through a hydraulic seal (Amor et al., 1999) and the membrane reactor with in-situ removal of products using a membrane (Struis et al., 2001). An increase in conversion will lead to a reduction in recycle compressor work as well as a reduction of the size of equipment in the recycle loop.

The aim of this work is to decrease the energy consumption of the conventional methanol process without increasing the conversion per pass and consequently the recycle flow. In fact, the high recycle and high operating pressure of the reactor is exploited to produce power by expanding the hot reactor outlet and compressing it again. By doing so a Brayton power cycle is created within the process that uses process gas as a working fluid. The reaction heat is utilised at the maximum possible temperature. Therefore, more power can be produced to drive the compressor compared to using a steam cycle and downgrading the heat in quality via heat transfer.

Expansion of the hot process gas can be achieved using available turbine expander technology. Turbine expanders are high efficiency turbines that specifically exclude steam and combustion gas turbines. Turbine expanders are mostly used in air-separation to expand down from 5 bar and in hydrocarbon processing plants to expand natural gas from as high as 200 bar. Most of the hydrocarbon gas expanders are designed for power recovery and are directly connected to a process compressor on the same shaft (Bloch, 2001a; Bloch, 2001b).

Power recovery applications are on the increase mainly due to a change in market conditions driven by growing environmental awareness and an increase in power costs (Bloch, 2001a). However, most turbine expanders are placed in tail gas, flue gas or purge gas streams. Direct expansion of reactor product gases to recover reaction heat is a new concept that poses new design challenges. Promising results were already obtained with conceptual studies on turbine expander integration in ammonia synthesis (Greeff et al., 2001a; Greeff et al., 2001b) as well as phthalic anhydride production (Perold et al., 2001).

5.2 Conventional methanol production

Methanol is produced by the catalytic conversion of synthesis gas. The following three overall equilibrium reactions are relevant in the synthesis (Struis et al., 2001):

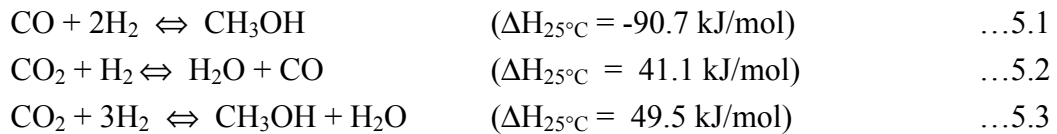

Only two of the three reactions are independent. Methanol formation is favoured by high pressures and low temperatures. The ICI process, introduced in 1966, is used for commercial production (Lunsford, 2000). This process was a major advance since it uses lower pressure than before and is based on more active Cu-ZnO-Al₂O₃ catalysts. Selectivities above 99% are possible and side reactions can therefore be ignored (Fielder et al., 1991). Temperatures above 210°C are required for catalyst activity. Reaction pressures are between 40 and 110 bar. Adiabatic (quench type) and isothermal (steam raising) reactors are used. The isothermal reactor is considered the most efficient system as the heat of reaction is utilised to raise medium pressure steam (Krupp Uhde, 2000).

The flow sheet shown in Figure 5.1 represents a typical conventional methanol synthesis loop. Synthesis gas 5 is compressed and mixed with recycle gas 7 in a multi-stage compressor. The compressor can be driven by an electrical motor, steam turbine or gas turbine. Hot product gas 3 is used to preheat the reactor feed 2 in HX1. Reaction heat is also used to raise steam. Further cooling takes place in HX2 to allow methanol and water to condense. The water and methanol are separated from the mixture in a flash drum and the crude methanol 10 (water-methanol mixture) is then further purified by distillation. Excess inerts (stream 8) are purged from the synthesis loop, taking some hydrogen and methane with them.

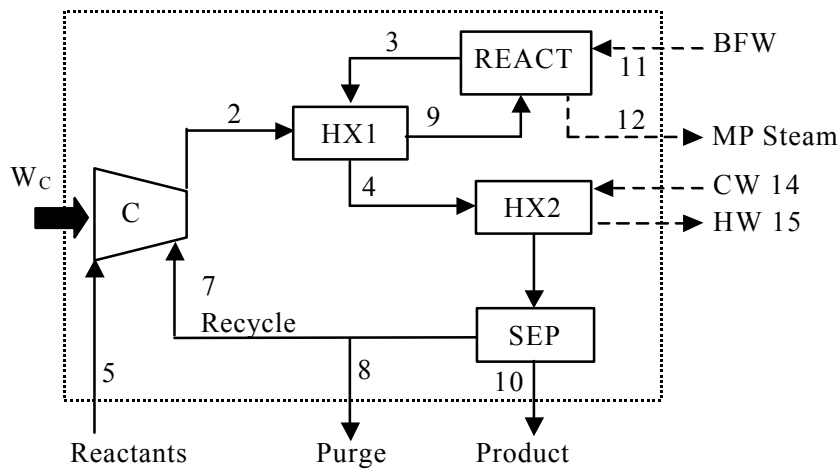

Figure 5.1 Process flow sheet for a methanol synthesis loop with steam raising isothermal reactor.

5.3 Development of a new flow sheet through application of power cycle principles

The power cycle used in the development of the new flow sheet is the Brayton cycle, shown in Figure 5.2. This cycle can be operated as a closed cycle utilising heat transfer processes or as an open cycle utilising an internal-combustion process. Thermal efficiency of the cycle depends on the pressure ratio and specific heat ratio. The work of compression or expansion depends on the pressure ratio, specific heat ratio and inlet temperature of the compressor or turbine. Therefore a low compressor inlet temperature and high turbine inlet temperature are needed to ensure that the net work developed is sufficient.

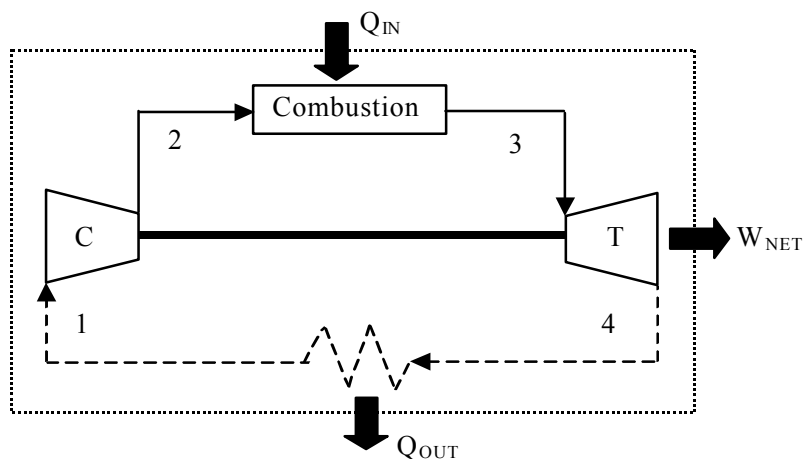

Figure 5.2 Brayton cycle.

The new flow sheet of the methanol plant with integrated power cycle is shown in Figure 5.3. The synthesis reactor replaces the conventional combustion process. The turbine expander T1 is placed directly after the reactor, utilising the high temperature of the process gas 3. The compressor C1 is added to compress the recycle gas 1. The expander T1 and compressor C1 pair comprises the process gas cycle. Note that in Figure 5.1 the recycle had to be compressed in the final stages of a multi-stage compressor due to frictional losses in the equipment. Such losses would be small compared to the pressure increase needed to bring the expanded recycle back to the required reactor pressure.

Separation takes place on the low pressure side of the system. The condensation of water and methanol from the gas mixture is not strongly dependent on pressure, therefore it is possible to condense at the same temperature as in the conventional case, but at lower pressure. This positioning of the separation operation has two advantages. First, the removal of product before recompressing the recycle reduces the compression requirements. Secondly, there is synergy in the sense that cooling is a requirement for the power cycle as well as for the process separation. Placing the separator on the low pressure side of the flow sheet satisfies the power cycle and process separation requirements in terms of cooling.

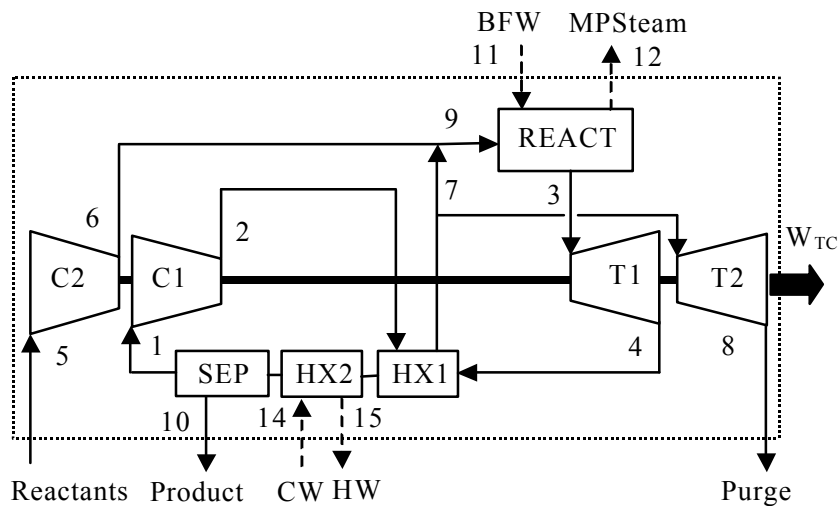

Figure 5.3 Integrated system with regeneration, separation on low pressure side and purge expansion on high pressure side.

The pre-heater HX1 uses the turbine outlet gas 4 to heat the recycle gas 2. It therefore acts as a regenerator which in Brayton power cycles is used to increase efficiency. In order to expand the maximum possible amount of gas, another expander, T2, is added to utilise the high pressure of the purge stream. The purge stream take-off is positioned directly before the reactor to provide the highest possible inlet temperature to the secondary expander.

The system shown in Figure 5.3 is a combination of an open and closed power cycle; it is partially open due to reactants flowing in, and product and purge streams leaving the system. Waste heat is rejected through cooling on the low pressure side, but will also be effected by the enthalpy difference between the material streams flowing across the system boundaries.

If the reactor in Figure 5.3 can be operated as adiabatic, all the reaction heat can be absorbed by the process gas to generate power in the process gas cycle. Whether this is possible or not will depend on the chemical kinetics and thermodynamics of the reactions (1-3), i.e. the effect of the temperature increase on the chemical kinetics and thermodynamics of these reactions. The alternative is to use a portion of the reaction heat to drive the process gas cycle and the remaining part to generate steam. Figure 5.4 shows the options for utilising the available reaction heat.

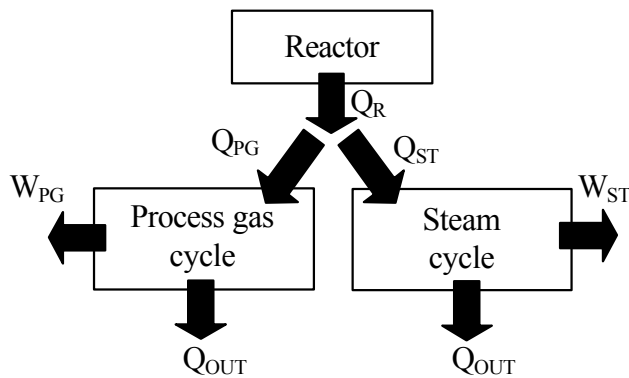

Figure 5.4 Options for the utilisation of reaction heat.

The advantage of using the reaction heat to drive the process gas cycle is that the heat is available at the temperature of the reaction, whereas the heat transferred to the steam cycle is lowered in quality due to the temperature driving force needed to transfer it.

If the reactor in the conventional flow sheet shown in Figure 5.1 is adiabatic (no steam generation), the reaction heat absorbed by the process gas would be wasted by cooling it away. This is why the isothermal steam generating reactor is a more efficient system for the conventional flow sheet from an energy point of view.

5.4 Simulation models

Process simulations of the conventional flow sheet and new flow sheet were created in AspenPlus 10.1 using the Peng Robinson method to calculate thermodynamic properties for

the real gas mixtures. The Peng Robinson method was also used for the vapour-liquid equilibrium calculations in the separator. Steam tables were used for water properties.

The steam generated in both flow sheets is expanded in a steam turbine. The duty of the pump to bring the water to the required pressure is neglected since this is a small fraction (less than 5%) of the compressor duty.

The following parameters are common to both systems and were specified in a similar manner:

- The synthesis reactor pressure is 90 bar.
- An equilibrium reactor is used to model the reactions.
- The temperature in the reactor is limited to 280°C.
- Cold separation is done at 30°C. Cooling water is available at 4 bar and 20°C, process streams are cooled to 30°C before entering the flash drum where the water and methanol are separated from the recycle gas stream.
- Heat exchangers are modelled using a short-cut method.
- 4% of the recycle is purged in order to prevent build-up of inert gases in the system.
- Minimum temperature in the cycle is 30°C.
- Reactants are assumed to be available at 30°C and 30 bar. The pressure of these reactants will depend on the pressure in the reforming section of the plant, which will depend on the type of reforming employed. Pressures are in the order of 14-24 bar for steam reforming and 40 bar for combined and autothermal reforming (Krupp Uhde, 2000).
- Isentropic efficiency of all machines is 80%.
- All machines are single stage.
- Frictional pressure losses through equipment are small compared to the pressure difference over the compression and expansion equipment. Therefore frictional pressure losses are ignored in both systems. Although the recycle stream 7 in Figure 5.1 is shown to pass through the compressor, it is simulated to mix directly with stream 2 after the compressor.
- A temperature difference of 20°C was used for HX1.
- In HX2 the flow rate of the cooling water is adjusted to obtain a hot water temperature 20°C lower than the hot process stream that is cooled.
- Reactants are fed at a rate of 135 ton/h (3240 ton/day).
- It was assumed that medium pressure steam is at 20 bar and low pressure steam at 4 bar, which are typical industrial values. It was further assumed that boiler feed water for steam generation is at 40°C. The flow rate of water is adjusted to render the required temperature for the high pressure steam. The temperature difference between the reactor and the high pressure steam is assumed as 20°C.

- Reactants have the following composition (mole fraction) based on an example of typical plant data :

N ₂	0.018	(inert)
H ₂	0.669	
CH ₄	0.028	(inert)
CO	0.191	
CO ₂	0.092	
CH ₄ O	0.002	

The only parameter that is not common to both systems is the turbine expansion pressure in the integrated flow sheet. Sensitivity analysis revealed that the optimum expansion pressure for power production is 70 bar and therefore this pressure was used. This corresponds to a pressure ratio of 1.3.

5.5 Simulation results and discussion

Simulation stream results are shown in Table 5.1 for comparison of the conventional and integrated flow sheets. The results show a small difference in conversion between the integrated and conventional systems. Sensitivity analysis revealed that the conversion in the integrated system is slightly influenced by the pressure ratio over the expander. Since the conversion dictates the amount of gas to be recycled, there are also slight differences in the flow rates of streams 3, 4 and 7.

The parameter used to judge the systems was the work required per kg of methanol produced. Note that the product stream is a mixture of methanol and water, W_{NETSP} is calculated using the methanol mass fraction of the flow which is 0.83 for both processes.

If the steam generated in the conventional process is not used to drive the feed compressor, 499 kJ/kg of compression work would be required. If a steam turbine is used to deliver some of the required work this value is reduced to 284 kJ/kg, as shown for the conventional process in Table 5.1. This corresponds to a 43% decrease in energy consumption. The integrated system, however, only consumes 215 kJ/kg methanol – a further reduction in energy consumption of 24%. This was achieved by reducing the amount of heat used to generate steam and utilising it more efficiently to drive the process gas cycle.

It is not only the reduction in quality of the available reaction heat that impacts negatively on the power production capacity of the conventional system. Table 5.1 shows that 13% of the reaction heat is absorbed by the process gas in the conventional system. The reactor inlet

stream is only heated to 260°C, 20°C below the reaction temperature of 280°C, due to the driving force needed for heat transfer in HX1. Some of the reaction heat is used to preheat the reactants, and is therefore not available to generate steam. In the integrated system the heat absorbed by the process gas is not lost, but utilised to drive the process gas cycle. An adiabatic reactor, with a high temperature rise, would be the most favourable case since all the reaction heat can be utilised at the maximum possible temperature. Unfortunately too high temperatures impact negatively on the reaction equilibrium.

Table 5.1 Mass and energy balance results (stream numbers correspond to Figure 5.1 for the conventional process and Figure 5.3 for the integrated process)

No.	Stream Name	Integrated Process				Conventional Process			
		n kmol/s	m ton/h	P bar	T °C	n kmol/s	m ton/h	P bar	T °C
1	-	11.74	531	70	30	-	-	-	-
2	-	11.74	531	90	56	14.42	633	90	58
3	Reactor out	12.82	645	90	280	12.78	633	90	280
4	-	12.82	645	70	255	12.78	633	90	103
5	Reactants	3.20	135	30	30	3.20	135	30	30
6	-	3.20	135	90	163	-	-	-	-
7	Recycle	11.27	510	90	235	11.22	497	90	30
8	Purge	0.47	21	30	137	0.47	21	90	30
9	Reactor in	14.47	645	90	220	14.42	633	90	260
10	Product	1.09	114	70	30	1.09	115	90	30
11	BFW	0.86	56	20	40	1.24	80	20	40
12	MP Steam	0.86	56	20	260	1.24	80	20	260
13	LP Steam ^a	0.86	56	4	145	1.24	80	4	145
14	CW	12.24	794	4	20	11.06	717	4	20
15	HW	12.24	794	4	92	11.06	717	4	83

Parameter	Work and heat streams (kW)	
W _{C1}	9 725	-
W _{C2}	13 191	13 191
W _{T1}	-11 749	-
W _{T2}	-1 550	-
W _{ST}	-3 937	-5 691
Q _R	74 255	74 199
Q _{ST}	44 472	64 286
Q _{PG}	29 783 (40%)	9 913 (13%)
Q _{HX2}	71 567	56 892
W _{NET}	5 681	7 500
W _{NETSP} kJ/kg	215	284

Single pass conversion		
CO	0.518	0.526
CO ₂	0.190	0.197

^a Stream no. 13 is not shown in the flow diagrams, it represents the steam flow after expansion in a steam turbine.

In comparing the systems only energy consumption, which forms part of operating costs, have been taken into account. Capital costs also have to be considered in determining the economic attractiveness of the new flow sheet. Economic analysis will of course be case and site specific. However, the additional capital cost of the turbine expander equipment may be offset by two factors. First, a reduction in the size of the steam system and steam turbine is possible in the new flow sheet. Secondly, a number of units operate at a lower pressure in the new flow sheet leading to a reduction in their costs.

5.6 Conclusions

A new methanol synthesis flow sheet that utilises the reaction heat more efficiently to drive the feed compressor was developed. In this flow sheet a portion of the reaction heat is used to drive a steam cycle and the rest of the heat is used to drive a process gas cycle. The process gas cycle consists of a compressor and turbine pair placed in the recycle stream. High pressure purge gas is also expanded to produce work.

The conventional and improved processes were compared based on the work required per kg of methanol produced. Results showed that the energy consumption of the conventional process with isothermal steam raising reactor can be reduced by 43% if a steam turbine is used to provide some of the compressor work. In the flow sheet with integrated turbine expander the energy consumption is reduced by another 24%. This was achieved by reducing the amount of heat used to generate steam and utilising it more efficiently to drive the process gas cycle. The most favourable case from the point of view of energy consumption would be to use an adiabatic reactor wherein all the reaction heat can be used to drive a process gas cycle. However, this leads to a high reactor temperature and reduction of conversion per pass in the reactor, due to the thermodynamic limitations.

5.7 References

Amor HB, Halloin VL, "Methanol synthesis in a multifunctional reactor", *Chemical Engineering Science*, vol. 54, pp. 1419-1423, 1999.

Bloch HP, "Consider turbo-expanders" (Editorial Comment), *Hydrocarbon Processing*, vol. 80, no. 1, p.1, 2001a.

Bloch HP, "Become familiar with turbo-expander applications" (Reliability), *Hydrocarbon Processing*, vol. 80, no.2, pp. 17-18, 2001b.

Fielder E, Grossmann G, Kerseböhm B, Weiss G and Witte C, "Methanol", in: Gerhartz W (Executive Editor), *Ullman's Encyclopaedia of Industrial Chemistry*, vol. 16, pp. 467-475, VCR Vertrieb Publishers, Dusseldorf, Germany, 1991.

Greeff IL, Ptasiński KJ and Janssen FJJG, "Integration of a turbine expander with an exothermic reactor for the combined production of power and ammonia", *Proceedings of ECOS 2001*, vol. 1, pp. 369-375, Öztürk, A. and Gögüs, Y.A. (editors), Istanbul, Turkey 2001a.

Greeff IL, Visser JA, Ptasiński KJ and Janssen FJJG, "Integration of a turbine expander with an exothermic reactor loop – flow sheet development and application to ammonia production", *Energy – The International Journal*, submitted for publication, 2001b.

Krupp Uhde, "Methanol Technology", Information Brochure, 2000.

Lunsford JH, "Catalytic conversion of methane to more useful chemicals and fuels: a challenge for the 21st century", *Catalysis Today*, vol. 63, pp. 165-174, 2000.

Moran MJ, Shapiro HN, *Fundamentals of Engineering Thermodynamics*, third ed., John Wiley & Sons Inc., New York, 1995.

Perold J, Greeff IL, Ptasiński KJ, Janssen FJJG, "Using a turbine expander to recover exothermic reaction heat – a case study on a phthalic anhydride process", *South African Journal of Chemical Engineering*, submitted for publication, 2001.

Struis RPWJ, Stucki S, "Verification of the membrane reactor concept for the methanol synthesis", *Applied Catalysis A: General*, vol. 216, pp. 117-129, 2001.

Tsibaki N, Zeng J, Yoneyama Y, Fujimoto K, "Continuous synthesis of methanol at low temperature from syngas using alcohol promoters", *Catalysis Communications*, vol. 2, pp. 213-217, 2001.

Chapter 6

Integration of a turbine expander with an exothermic reactor loop – flow sheet development and application to ammonia production*

This paper investigates the direct integration of a gas turbine power cycle with an ammonia synthesis loop. Such a loop represents a typical reactor-separator system with a recycle stream and cold separation of the product from the recycle loop. The hot reaction products are expanded directly instead of raising steam in a waste heat boiler to drive a steam turbine. Two new combined power and chemicals production flow sheets are developed for the process. The flow sheets are simulated using the flow sheet simulator Aspen Plus (licensed by Aspen Technology, Inc.) and compared to a simulated conventional ammonia synthesis loop. The comparison is based on energy as well as exergy analysis. It was found that the pressure ratio over the turbine expander plays an important role in optimisation of an integrated system, specifically due to the process comprising an equilibrium reaction. The inlet temperature to the reactor changes with changing pressure ratio, which in turn determines the conversion and consequently the heat of reaction that is available to produce power. In terms of the minimum work requirement per kg of product a 75% improvement over the conventional process could be obtained. The work penalty due to refrigeration needed for separation was also accounted for. Furthermore this integrated flow sheet also resulted in a decrease in exergy loss and the loss was more evenly distributed between the various unit operations. A detailed exergy analysis over the various unit operations proved to be useful in explaining the overall differences in exergy loss between the flow sheets.

* Published paper: Greeff IL, Visser JA, Ptasiński KJ and Janssen FJJG, "Integration of a turbine expander with an exothermic reactor loop – flow sheet development and application to ammonia production", *Energy – The International Journal*, vol. 28, issue 14, pp. 1495-1509, 2003.

Nomenclature

I	Process irreversibility or exergy loss (kW)
I_{SP}	Exergy loss per kg product (kJ/kg)
k	Specific heat ratio (-/-)
m	Flow rate (kg/h)
n	Flow rate (kmol/s)
P	Pressure (bar)
Q_{DUMP}	Heat dumped to the environment by a heat pump (kW)
Q_{HX}	Heat exchanger duty (kW)
Q_{IN}	Heat input to a power cycle (kW)
Q_{OUT}	Heat removed from a power cycle (kW)
Q_{REACT}	Heat of reaction (kW)
Q_{SEP}	Heat removed to cool below environmental temperature in cryogenic separation (kW)
R	Ideal gas constant (= 8.314 kJ/(kmol.K))
T	Temperature (°C or K)
T_C	Temperature of cold reservoir (K)
T_H	Temperature of hot reservoir (K)
W_{NET}	Net work produced by or required by a system (kW)
W_{NETSP}	Net work produced or required per kg product (kJ/kg)
W_T	Total work produced by expanders (kW)
W_C	Total work required by compressors (kW)
W_{SEP}	Minimum work required for separation (kW)
W_{TC}	Sum of compression and expansion work (kW)

Greek Symbols

β	Coefficient of performance of a refrigeration cycle
η	Power cycle efficiency

Flow sheet abbreviations

C	Compressor
CW	Cold Water
HX	Heat Exchanger
HW	Hot Water
ST	Steam Turbine
Sep	Separator
T	Turbine
WHB	Waste Heat Boiler

6.1 Introduction

In the chemical industry many exothermic reactions are carried out. The reaction heat is often transferred by heat exchange to another medium for use at a different location. Steam raising systems are commonly used. The steam may be exported to another process plant, used for process heating or used to generate power in steam turbines, either for export or process requirements. An alternative to generating power in steam turbines is to expand the hot reactor product gases directly to produce work in a turbine expander. From an exergetic viewpoint this is a more efficient way of utilising the heat for power production, mainly as the number of unit operation involved will be reduced.

Turbine expanders that are integrated into chemical processes are mostly placed in tail gas, flue gas or purge gas streams. Examples of such systems are described in the patents by Parmegiani et al. (1971), Horton (1969) and Linnhoff et al. (1993).

Very few examples exist of expansion turbines used for direct expansion of reactor product gas to recover reaction heat. In such systems the turbine expander may impact significantly on downstream operations, optimum process conditions or even the process configuration. The process gas used as a working fluid will often be in an intermediate stage of processing, *en route* to downstream unit operations, for example separation or purification. The patent of Janssen et al. (1997) describes a process for the synthesis of ethene from methane. The exothermic reaction takes place over a catalyst in the combustion chamber of a gas turbine. The reaction products are expanded and the turbine drives the methane and combustion air compressor. The cycle is open with no recycle of reaction products. More recently Agee et al. (2000) patented a synthesis gas production system comprising a gas turbine with an autothermal reformer between the compressor and expander. The reformer uses a combination of partial oxidation and steam reforming. The exothermic heat of the partial oxidation step provides the heat for the endothermic steam reforming reaction. The reformer produces synthesis gas and serves as the combustor for the gas turbine.

In addition to the patent literature two conceptual case studies on the subject have recently been published, namely a study on turbine expander integration in phthalic anhydride production by Perold et al. (2001) and a study on methanol production by Greeff et al. (2002). Both these case studies showed promising results concerning energy saving in the production of typical chemicals in the integrated processes compared to the conventional processes.

The aim of the current paper is to investigate the integration of a turbine expander with an ammonia synthesis loop. Ammonia is a world-class commodity as it is produced in over 80

countries. The main application of ammonia is for nitrogen-based fertilisers. The energy consumption in ammonia production has been significantly reduced in the last decades but it is still 40-50 % above the thermodynamic minimum (Appl, 1999). The majority of ammonia plants use natural gas, naphtha or LPG as a feedstock. Reduction of the energy consumption in ammonia plants will result not only in saving fossil fuels, but also in reduction of environmental impact of emitted carbon dioxide. Ammonia plants are based on a mature technology and further reduction of energy consumption can mainly be expected due to better process integration, in this case improved integration between chemical and energy elements of the plant.

The ammonia synthesis loop represents a typical reactor-separator system with a recycle stream and cold separation of the product from the recycle loop. New combined power and chemicals production flow sheets are presented for the process. These flow sheets are simulated using the flow sheet simulator AspenPlus (licensed by Aspen Technology, Inc.) and are compared to a simulated conventional ammonia synthesis loop. The comparison is based on energy as well as exergy analysis. The exergies of the material streams were calculated using the Exercom subroutines developed to run with AspenPlus (Hinderink et al., 1996). The reference environment suggested by Szargut et al. (1988) is used in these calculations.

6.2 Direct conversion of reaction heat to electrical energy

Different systems can be used for the conversion of reaction heat to power. Figure 6.1 shows an example of a system comprising an adiabatic exothermic reactor, similar to the type of reactor used for ammonia synthesis. System boundaries are indicated using dotted lines. A high-pressure gas-phase chemical reaction takes place in the reactor. Since the reactor is adiabatic the rise in internal energy of the reacting mixture appears as a rise in temperature over the reactor. The reaction product exchanges heat with a pressurised utility fluid to recover the reaction heat. The heated utility fluid is used to generate power by expanding it in a utility turbine. The purpose of the system is therefore to recover reaction heat and use this heat to generate power. The working fluid of the energy system and the process fluid are separated. In cooled chemical reactors the heat exchanger is integrated with a reactor, however, the intermediate utility fluid must still be used.

Power generation using exothermic reaction heat can however also be achieved by direct expansion of the hot, high-pressure product gas in a turbine expander, as shown in Figure 6.2. The advantage of this concept is that no heat exchange to another working fluid is necessary. Additional thermodynamic losses associated with such heat exchange are avoided. The process fluid that is expanded is at a higher temperature compared to the utility fluid in the

conventional system in Figure 6.1. Due to the required temperature driving force for heat exchange the utility fluid will always be at a lower temperature compared to the reactor product gas.

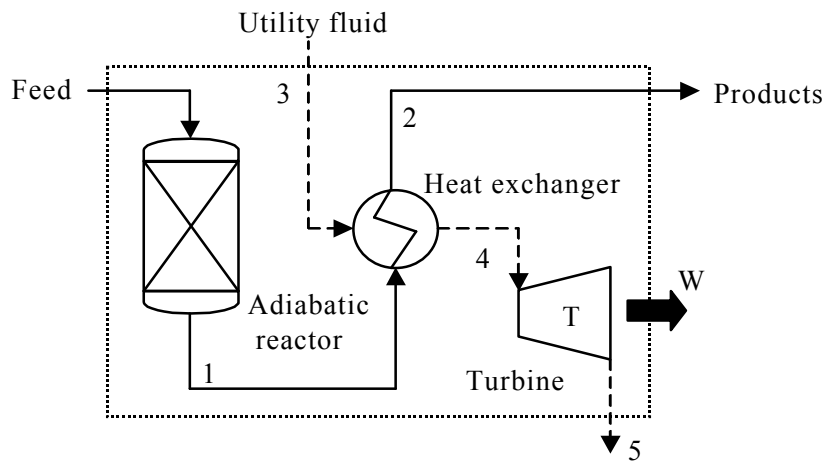

Figure 6.1 Exothermic adiabatic reactor with product heat exchanger and utility turbine.

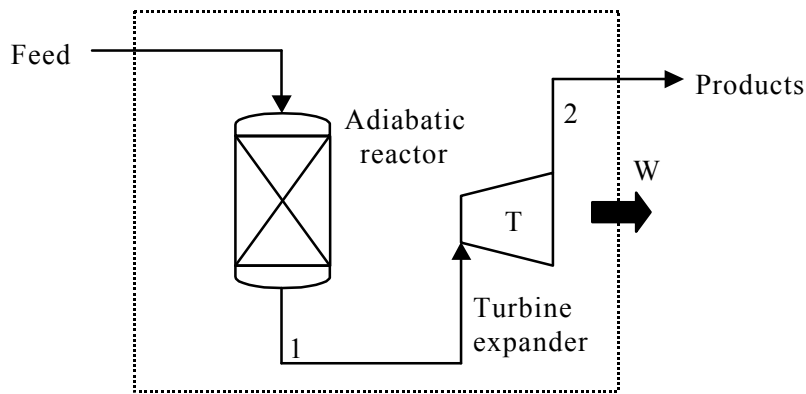

Figure 6.2 Exothermic adiabatic reactor with product turbine expander.

The main difference between the two systems is in the level of process integration. The integration of chemical processes and energy conversion devices in chemical plants can take place at various levels, as demonstrated by Dijkema et al. (1998), who have considered five possible integration levels. The system-integration level in this paper corresponds to level 4 of Dijkema et al., that is the integration of an energy conversion device and a chemical unit operation. The indirect system shown in Figure 6.1 includes five process elements, namely the chemical reactor, heat exchanger, turbine, chemical products and utility streams, whereas

the direct system shown in Figure 6.2 only includes three process elements, namely the chemical reactor, turbine, and chemical products stream. In this paper the proposed concept of direct conversion of reaction heat into power is superimposed onto the classical ammonia production flow sheet. From the conceptual point of view this can be seen as retrofitting an existing ammonia plant.

The heat that is used to generate power is more valuable or of higher quality, since its temperature is further from the ambient. From a Second Law or exergetic viewpoint, it is therefore more efficient to recover reaction heat by direct expansion of the hot, high-pressure product gas in a turbine expander. The reaction heat is utilised at the maximum possible temperature to produce power using the process gas as the working fluid. Table 6.1 summarises and compares the qualitative characteristics of the two reaction heat recovery systems discussed above.

Table 6.1 Qualitative comparison of reaction heat recovery systems.

	Product turbine expander	Product heat exchanger and utility turbine
1	Heat for power generation is available at the maximum temperature of the system at the reactor outlet, T_1 .	Heat for power generation is available at the utility fluid temperature, T_4 . $T_4 = T_1 - \Delta T$ where ΔT is the temperature difference on the hot side of the heat exchanger.
2	Process fluid is used as a working fluid.	Utility fluid is used as a working fluid.
3	Pressure of the products, P_2 , is considerably lower than P_1 due to the expansion.	Pressure of the products, P_2 , is similar to P_1 .
4	One process unit, namely the turbine expander, is needed to convert the reaction heat to power.	Two process units, namely the heat exchanger and utility turbine are needed to convert the reaction heat to power.
5	This system can utilise the pressure and thermal exergy of stream 1 to produce power.	Only the thermal exergy of stream 1 can be used to produce power.

The advantages of the integrated system shown in Figure 6.2 can be demonstrated in different ways. The most common evaluation approaches can be based on thermodynamic efficiency (the Second Law of thermodynamics and exergy analysis), environmental impact and costs. The main purpose of this paper is to demonstrate the system improvement based on exergy analysis as it is commonly accepted for chemical and energy systems (Kotas, 1983; Tsatsaronis, 1999; Sukumaran Nair, 2000; Moran et al., 1995). In the ammonia plant two different components are involved, being chemical products and power, and exergy analysis is the most suitable tool for the plant evaluation. More efficient conversion of the reaction heat to electricity also translates into a benefit to the environment, due to decreased emissions of CO_2 , NO_x and SO_x associated with power generation from fossil fuels. The full cost

analysis should involve not only operational and capital costs, but also the expected costs due to carbon dioxide mitigation, and such analysis is outside the scope of the present paper.

6.3 Conventional ammonia production

Ammonia is produced from its elements using the Haber process. The reaction:

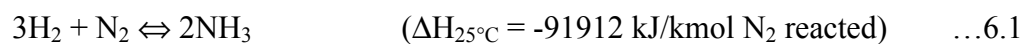

takes place over a catalyst in a quench type reactor for careful control of temperature. The equilibrium conversion of ammonia increases with rising pressure and decreasing temperature. Due to kinetic considerations however, the reactor must be operated at higher temperatures. Plants built in the 70's and 80's operate at a loop pressure of 200-250 bar. In the latest technologies the loop pressure has been decreased to between 80 and 150 bar (Sukumaran Nair, 2000).

The schematic shown in Figure 6.3 is used to represent a typical conventional ammonia synthesis loop with steam generation, referred to in the remaining part of this paper as system A. Reactants 5, consisting of hydrogen and nitrogen, approximately in the stoichiometric ratio of 3:1, are compressed and introduced into a circulatory system where they are combined with the recycle gas 7. Multistage compressors, driven by high pressure steam turbines, are used.

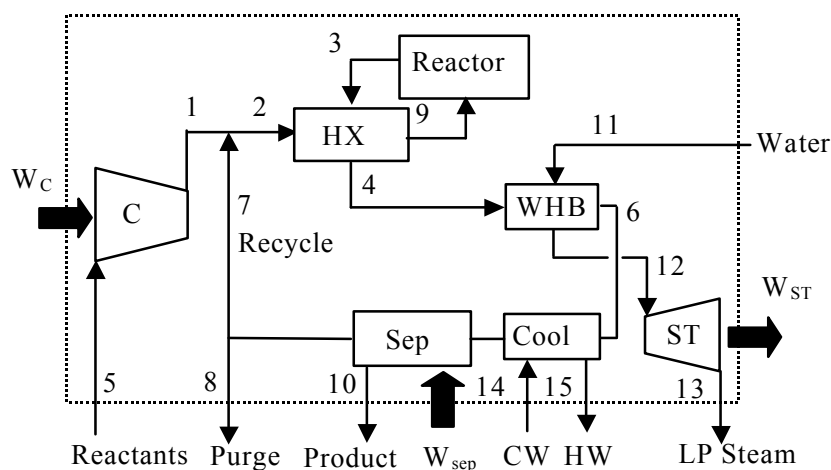

Figure 6.3 Conventional ammonia synthesis loop with steam generation (system A).

Ammonia 10 is recovered from the loop by condensing it from the gas using a combination of cooling water and ammonia chilling, i.e. ammonia refrigerant is used in a compression

refrigeration cycle. The main differences in various synthesis loop arrangements are the points where reactants are introduced and product recovered. Separation of ammonia is carried out at a pressure similar to the reactor pressure. Ammonia and hydrogen from the purge gas 8 is usually recovered and recycled back to the loop. The reactor outlet 3 is used to preheat the inlet 2, where after reaction heat is also recovered in a waste heat boiler, (WHB), to generate high pressure steam 12. The high pressure steam is expanded to produce power in a steam turbine (ST).

6.4 Ammonia synthesis system integrated with a turbine expander

Two ammonia synthesis flow sheets with integrated turbine expanders were developed. The approach followed in the development of the concept is to look at the requirements for power production and chemical production separately before these processes are integrated. It is important to note that it is not just an energy conversion unit operation that is added to an existing chemical process, but a power production cycle that should be combined with the chemical process in such a way that the requirements of both the power cycle and the chemical process are satisfied. The requirements for a reactor-separator scheme with recycle are:

- Continuous feed of reactants and a separation operation for removal of product.
- A purge stream is needed to prevent a high concentration of inert gases accumulating in the recycle loop. The purge take-off should be positioned between the separator and the reactor to prevent unnecessary loss of product.
- A compressor is needed to move the gas and obtain the required reactor pressure.

The power cycle to be used for the integration is the Joule or Brayton cycle (Moran et al., 1995), shown in Figure 6.4. In a real gas turbine plant the heat transfer area for heating is eliminated by burning fuel directly in the working fluid (combustion). The waste heat is rejected into the atmosphere, eliminating the need for separate cooling. The air-standard model equations can provide valuable qualitative indications for what is required to produce power. Thermal efficiency depends on the compressor ratio and the specific heat ratio of the working fluid:

$$h = 1 - \left(\frac{P_{out}}{P_{in}} \right)^{\frac{1-k}{k}} \quad \dots 6.2$$

The work of compression or expansion depends on the pressure ratio as well as the inlet temperature of the compressor or turbine:

$$W = \frac{nkRT_{in}}{k-1} \left[\left(\frac{P_{out}}{P_{in}} \right)^{\frac{k-1}{k}} - 1 \right] \quad \dots 6.3$$

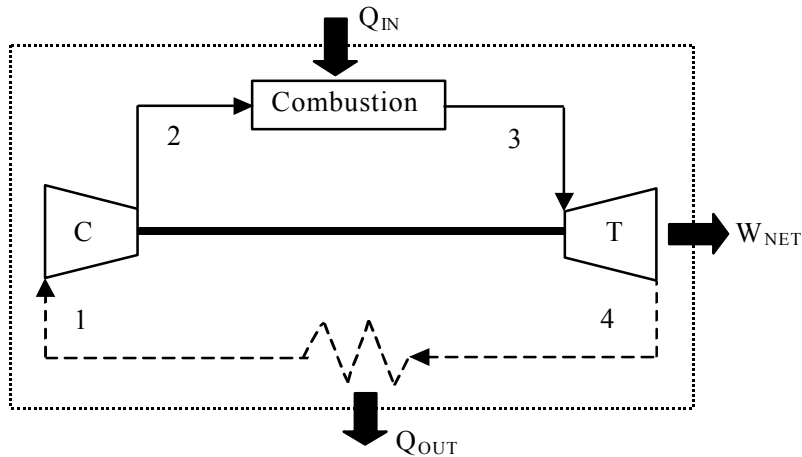

Figure 6.4 Brayton cycle.

The requirements for power production therefore are:

- A relatively high pressure ratio over the compressor in order to obtain a reasonable cycle efficiency.
- A low compressor inlet temperature and a high turbine inlet temperature to ensure that the net work developed are sufficient.
- Minimisation of the amount of gas to be compressed and maximisation of the amount of gas to be expanded.
- A source of heat is needed in order to drive the cycle.

By superimposing the Brayton cycle onto the ammonia reactor-separator system the two flow sheets shown in Figure 6.5 and 6.6 and referred to as systems B and C respectively were obtained. In both flow sheets a turbine expander is placed directly behind the ammonia reactor. The chemical reactor, where heat is produced due to exothermic reaction, replaces the combustion step of Figure 6.4. In system B the cold separation is on the high pressure side of the system whereas in system C the separation is on the low pressure side. It will be shown later how the pressure influences the separation. In both flow sheets purging is done from the high pressure side of the system and the purge streams are also expanded to produce power.

In both systems the requirements for ammonia production and power production are met. The process gas, which is now also the working fluid for a power cycle, undergoes the necessary state changes to complete a Brayton-type cycle, namely compression to the maximum

working pressure, heat addition, expansion to the initial pressure and heat release. The systems are also combinations of open and closed power systems; they are partially open due to reactants flowing in and product and purge streams leaving the system boundaries. Waste heat can be rejected through cooling on the low pressure side, but will also be effected by the enthalpy difference between the material streams flowing across the system boundaries.

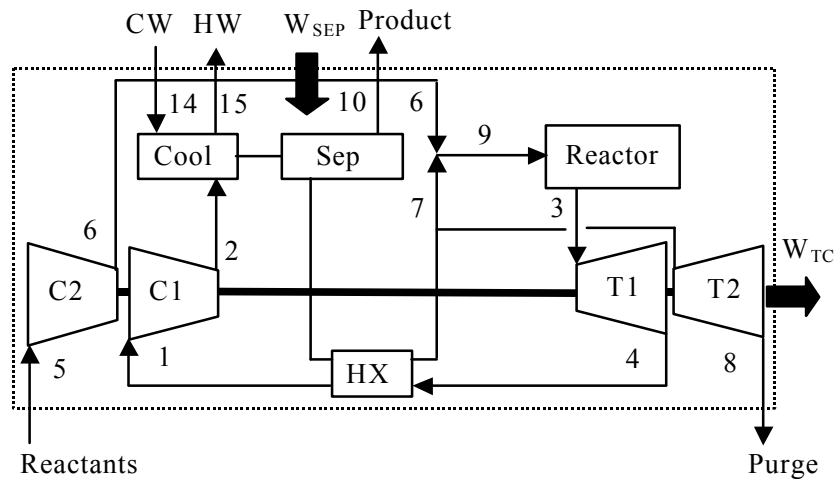

Figure 6.5 Integrated ammonia synthesis flow sheet with separation on high pressure side (system B).

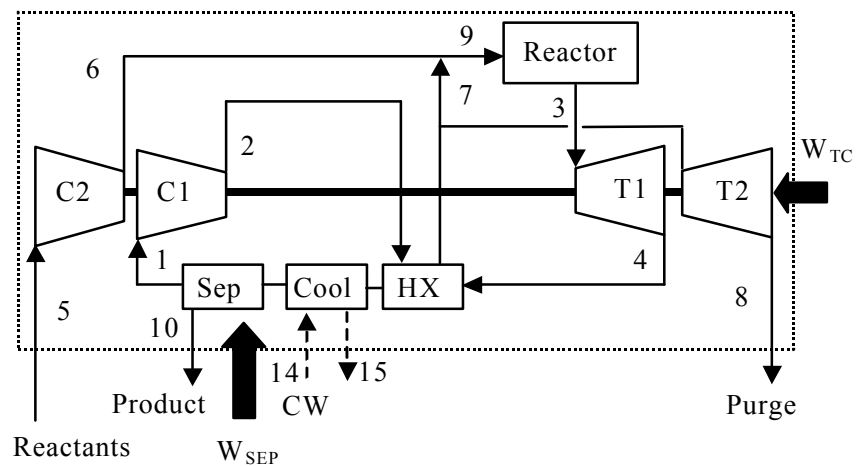

Figure 6.6 Integrated ammonia synthesis flow sheet with separation on low pressure side (system C).

In both cases the thermal efficiency of the system can be increased using the concept of heat regeneration. A heat exchanger, HX, is added to exchange heat between the turbine outlet and a process stream on the high pressure side.

6.5 Simulation models

The conventional and newly integrated processes were simulated in AspenPlus, using the Redlich-Kwong-Soave method to calculate thermodynamic properties for the real gas mixtures. This property method was also used for the vapour-liquid equilibrium calculations in the separator.

Heat exchangers are modelled using a short-cut method in AspenPlus. The hot and cold inlet streams are specified and the user is allowed to choose one of a number of performance specifications. In this case the temperature difference between the streams at the cold stream outlet was chosen to specify the performance. Other performance parameters that may be chosen are the heat exchanger duty, surface heat transfer duty, degree of superheating etc.

The following parameters are common to the systems and are specified in a similar manner with similar assumptions:

- The synthesis reactor pressure is 213 bar.
- An equilibrium reactor is used to model the reaction.
- The reactor is assumed to be adiabatic.
- Cold separation is done at -23 °C. Cooling water is available at 4 bar and 20 °C, process streams are cooled to 25 °C before entering the refrigeration section of the cold separation unit.
- 7% of the recycle is purged in order to prevent build-up of inert gases in the system.
- Minimum temperature in the cycle is -23 °C.
- Reactants are available at 30 °C and 30 bar and are fed at a rate of 65 650 kg/h (1576 ton/day).
- Isentropic efficiency of all machines is 80%.
- All machines are single stage.
- No pressure losses are allowed for through equipment since these losses would be small compared to the pressure difference across the compressors and expanders.
- Reactants have the following composition (mole %) based on an example of typical plant data:

N ₂	24.6
H ₂	73.2
CH ₄	1.8
Argon	0.004

The parameters that are not common to both systems are the steam generation conditions in the conventional process and the choice of pressure (pressure ratio) for the expansion in the integrated systems. The choice of these parameters was given special attention:

Choice of steam generation conditions

It was assumed that high pressure steam is at 40 bar and low pressure steam at 4 bar, which are typical industrial values. It was further assumed that the water is available at 40 °C and 40 bar and that the temperature of stream 6 in the conventional system is 160 °C as per typical plant data. With the assumed hot stream temperature difference for the waste heat boiler (WHB) of 10 °C, the flow rate of water is adjusted to render the required temperature for stream 12, depending on the temperature of stream 4.

Choice of expansion pressure/pressure ratio

Since the ammonia reactor is an equilibrium reactor the inlet temperature to the reactor determines the conversion. The conversion decreases with an increase in temperature, thereby decreasing the heat released by the reaction. Different pressure ratios render different reactor inlet temperatures and sensitivity analyses were done to determine this relationship. Optimum turbine expansion pressures were determined for the two integrated ammonia flow sheets.

Refrigeration work penalty

To estimate the work penalty due to the cold separation, it is assumed that the cooling is done using an ideal refrigeration cycle (heat pump). A schematic of this heat pump in relation to the process is shown in Figure 6.7. The gas is cooled from 25 °C to the separation temperature of -23°C. The minimum work required for cooling is calculated using the maximum coefficient of performance for a refrigeration cycle:

$$\mathbf{b} = \frac{T_C}{T_H - T_C} = \frac{Q_{SEP}}{W_{SEP}} \quad \dots 6.4$$

For a reversible refrigerator operating between 250 K (-23 °C) and 303 K (25 °C) $\beta = 5.2$.

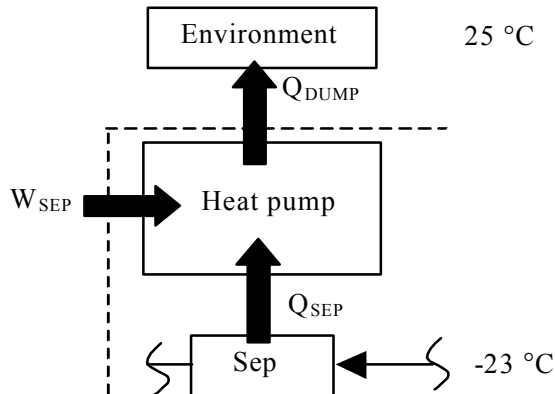

Figure 6.7 Schematic of a heat pump.

6.6 Simulation results and discussion

Simulation runs have shown that all the investigated systems, these are the conventional ammonia synthesis, and both integrated ammonia synthesis systems require net work input. The important variable during the simulation of integrated ammonia systems B and C was the expansion pressure, which has a large influence on the performance of both systems. Sensitivity analyses revealed that the optimum expansion pressure for power production is 110 bar for system B and 80 bar for system C. At these expansion pressures the systems required the minimum amount of work per kg of ammonia produced, a parameter that gives an indication of operating costs. Results of these sensitivity analyses are shown in Figure 6.8 and 6.9.

Simulation stream results for these cases are shown in Table 6.2 for comparison of systems A, B and C. Since the single pass conversions are different, the recycle flows also differ. All the heat and work parameters that depend on the recycle flow rate are therefore different. The systems all require a net work input, as previously stated. However, considering the minimum work required per kg product, the integrated systems are a great improvement over the conventional system A. System A requires a W_{NETSP} of 1269 kJ/kg. System B requires 706 kJ/kg, representing a 44% improvement over system A. System C only consumes 315 kJ/kg, representing a 75% improvement over the conventional system A.

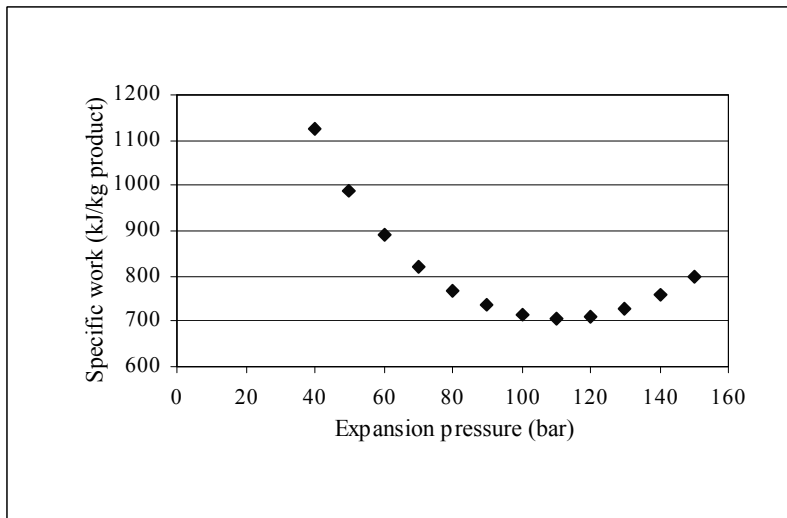

Figure 6.8 W_{NETSP} versus turbine expansion pressure for system B.

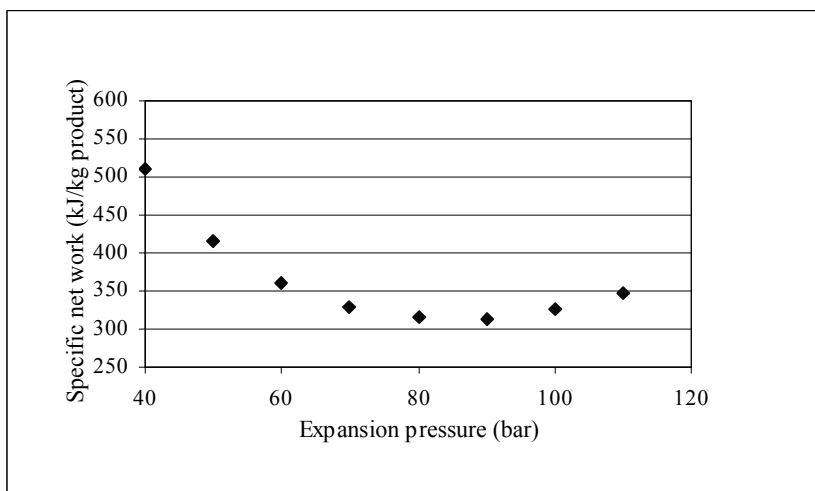

Figure 6.9 W_{NETSP} versus turbine expansion pressure for system C.

Considering the exergy analysis results reported in Table 6.2, the total exergy loss for system B is 11% lower and for system C 22% lower compared to the conventional system A. The specific exergy loss, I_{SP} , is however similar for systems A and B, but 15% lower for system C compared to system A. The specific exergy loss also varies with pressure ratio across the turbine expander. The expansion pressures for minimum I_{SP} do not correspond to those reported for minimum W_{NETSP} . Variation of I_{SP} with turbine expansion pressure is shown in Figure 6.10 and 6.11 for systems B and C respectively. Minimum I_{SP} is obtained at an expansion pressure of 80 bar for system B and at 70 bar for system C.

Table 6.2 Mass, energy and exergy balance results

Stream	System A				System B				System C			
No.	n kmol/s	m kg/h	P bar	T °C	n kmol/s	m kg/h	P bar	T °C	n kmol/s	m kg/h	P bar	T °C
1	2.07	65650	213	311	8.73	319549	110	37	6.90	244190	80	-23
2	6.94	237936	213	72	8.73	319549	213	114	6.90	244188	213	77
3	6.09	237936	213	510	8.73	319547	213	569	7.69	292745	213	535
4	6.09	237936	213	276	8.73	319549	110	469	7.69	292749	80	399
5	2.07	65650	30	30	2.07	65650	30	30	2.07	65650	30	30
6	6.09	237936	213	160	2.07	65650	213	311	2.07	65650	213	311
7	4.87	172286	213	-23	7.41	253897	213	464	6.41	227095	213	394
8	0.37	12968	213	-23	0.56	19110	30	227	0.48	17093	30	180
9	6.94	237936	213	302	9.48	319547	213	432	8.49	292745	213	375
10	0.86	52682	213	-23	0.76	46542	213	-23	0.79	48559	80	-23
11	0.46	30000	40	40	-	-	-	-	-	-	-	-
12	0.46	30000	40	266	-	-	-	-	-	-	-	-
13	0.46	30000	4	145	-	-	-	-	-	-	-	-
14	3.62	235000	4	20	3.76	243633	4	20	2.83	183749	4	20
15	3.62	235000	4	134	3.76	243633	4	109	2.83	183749	4	119
Parameter	System A				System B				System C			
W _{C1}	-				21904				21815			
W _{C2}	-				17948				17948			
W _C	17948				39853				39763			
W _{T1}	-				-31239				-37634			
W _{T2}	-				-4337				-3411			
W _{ST}	-2884				-				-			
W _T	-2884				-35576				-41045			
W _{TC}	15064				4276				-1282			
W _{SEP}	3503				4855				5525			
W _{NET}	18566				9132				4243			
Q _{REACT}	-38962				-34731				-36682			
Q _{SEP}	-18253				-25304				-28793			
Q _{DUMP}	-21756				-30160				-34318			
Q _{WHB}	24224				-				-			
Q _{Cool}	36356				29280				24482			
W _{NETSP}	1269				706				315			
I	26924				23900				21072			
I _{SP}	1840				1849				1562			
Single pass conversion												
H ₂	0.26				0.17				0.20			

In Table 6.3 systems A and C are compared based on a detailed exergy analysis. This gives some insight into the difference in total exergy loss between these systems. In both systems a large exergy loss occurs across the reactor, in system C this loss is lower due to the lower conversion. The exergy loss over the feed product heat exchanger in system A contributes an alarming 39% to the total loss. In system C the exergy loss is not only decreased but is also more evenly distributed between the various unit operations.

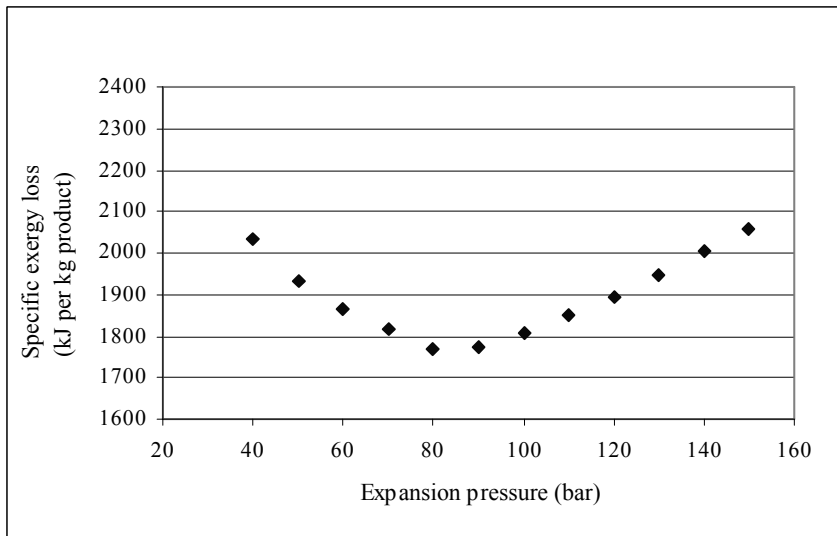

Figure 6.10 I_{SP} versus turbine expansion pressure for system B.

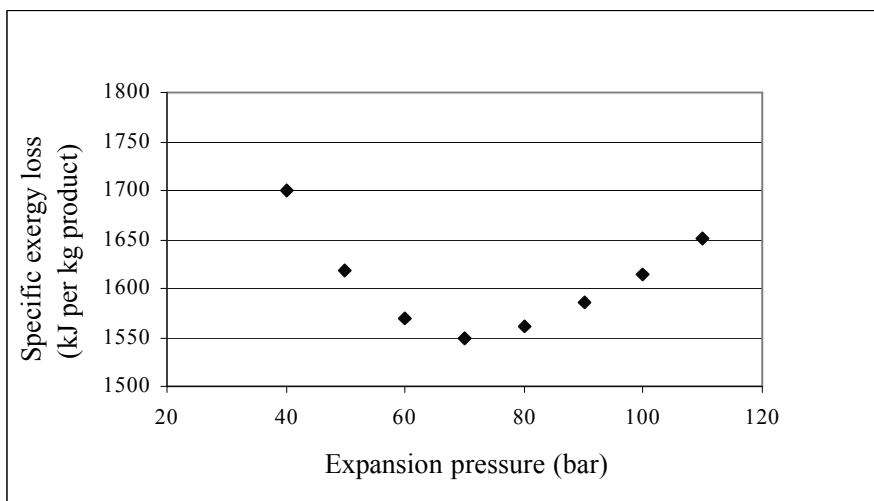

Figure 6.11 I_{SP} versus turbine expansion pressure for system C.

The results obtained here on energy savings in the ammonia process are comparable to the results obtained in the production of other typical chemical products. Results of a methanol synthesis case study showed that a 24% energy saving is possible inserting a turbine expander on the methanol reactor outlet (Greeff et al., 2002). In another case study on phthalic anhydride (Perold et al., 2001) it was demonstrated that the amount of power generated is increased from 2.7 MW to 8.1 MW by using a turbine expander on the reaction outlet in combination with the steam turbine cycle that extracts heat from the reactor.

Table 6.3 Exergy losses over individual unit operations in kW.

Unit operation	System A	System C
		Expansion pressure: 80 bar
C	1928	-
C1	-	3835
C2	-	1928
T1	-	4256
T2	-	601
ST	514	-
Reactor	5880	4260
Sep	1988	2945
HX	10520	2550
WHB	423	-
Cool	117	296
Recycle mix	5553	403
Total	26924	21072

6.7 Conclusions

A turbine expander was successfully integrated with an ammonia synthesis process to produce two alternative improved process flow sheets. The ammonia synthesis process represents a typical reaction-separation system with recycle stream and cold separation of the product. In the integrated flow sheets the reaction heat of the exothermic reaction is used more efficiently to produce power. The hot reaction products are expanded directly instead of raising steam in a waste heat boiler to drive a steam turbine.

It was found that the pressure ratio over the turbine expander plays an important role in optimisation of an integrated system, specifically due to the process comprising an equilibrium reaction. The inlet temperature to the reactor changes with changing pressure ratio. This in turn determines the conversion and consequently the heat of reaction that is available to produce power. Sensitivity analyses were used to determine the pressure ratios for the minimum work requirement per kg product as well as the minimum exergy loss per kg of product.

In terms of the minimum work requirement per kg of product the better of the two integrated flow sheets showed a 75% improvement over the conventional process. The work penalty due to refrigeration needed for separation was also accounted for. Furthermore this integrated flow sheet also resulted in a decrease in exergy loss and the loss was more evenly distributed

between the various unit operations. A detailed exergy analysis over the various unit operations proved to be useful in explaining the overall differences in exergy loss between the flow sheets.

6.8 References

Agee MA, Weick LJ, Agee KL and Trepper EL, "Synthesis gas production system and method", *US Patent 6155039*, assigned to Syntroleum Corp (US), 2000.

Appl M, *Ammonia: principles and industrial practice*, J. Wiley, Weinheim, 1999.

Dijkema GPJ, Luteijn CP and Weijnen MPC, "Design of trigeneration systems", *Chemical Engineering Communications*, vol. 168, pp. 111-125, 1998.

Greeff IL, Visser JA, Ptasinski KJ and Janssen FJJG, "Utilisation of reactor heat in methanol synthesis to reduce compressor duty – application of power cycle principles and simulation tools", *Applied Thermal Engineering*, vol. 22, pp. 549-1558, 2002.

Hinderink AP, Kerkhof FPJM, Lie ABK, De Swaan Arons J and van der Kooi HJ, "Exergy analysis with a flowsheeting simulator – I. Theory; Calculating exergies of material streams", *Chemical Engineering Science*, vol. 51, no. 20, pp. 4693-4700, 1996.

Horton A, "Process and Apparatus for the Manufacture of Nitric acid", *UK Patent GB1146292*, assigned to Humphreys and Glasgow Ltd., 1969.

Janssen FJJG, Verkooijen AHM and Ploumen PJ, "Synthesis of ethane", *European Patent 0753652*, assigned to N.V. Kema, The Netherlands, 1997.

Linnhoff B, Le Leur JE and Pretty BL, "Exothermic chemical reaction processes", *European Patent 0301844B1*, assigned to British Technology Group Ltd., GB, 1993.

Kotas TJ, *The exergy method of thermal plant analysis*, London: Butterworths, 1985.

Moran MJ, Shapiro HN, *Fundamentals of Engineering Thermodynamics*, third ed., John Wiley & Sons Inc., New York, 1995.

Parmegiani M, Milanese SD and Bellofatto O, “Process for the utilization of the exhausted gases from an ethylene oxide synthesis reactor”, *US Patent 3552122*, assigned to Snam Progetti, Milan, Italy, 1971.

Perold J, Greeff IL, Ptasinski KJ, Janssen FJJG, “Using a turbine expander to recover exothermic reaction heat – a case study on a phthalic anhydride process”, *South African Journal of Chemical Engineering*, vol. 13, no. 2, pp. 1-14, 2001.

Sukumaran Nair MP, “Use monitoring programs to improve ammonia plant uptime”, *Hydrocarbon Processing*, vol. 79, no. 2, 2000.

Szargut J, Morris DR and Steward FR, *Exergy analysis of thermal, chemical and metallurgical processes*, Hemisphere Publishing, New York, 1988.

Tsatsaronis G, “Strengths and limitations of exergy analysis”, in: Bejan A, Mamut E (editors), *Thermodynamic optimization of complex energy systems*, pp. 93-100, Kluwer, Dordrecht, 1999.

Chapter 7

Recovering of reaction heat in the oxygen-based synthesis of ethylene oxide

This case study presents a process with large recycle and two separation operations at different pressure levels. A large amount of heat is released by the relevant oxidation reactions making energy recovery and integration a prime concern. The reaction to form CO₂ and water, which are byproducts, has a heat of reaction that is in the order of twelve times that of the reaction to form ethylene oxide. The reaction heat thus originates from an unwanted reaction. The selectivity parameter therefore plays an important role in this case study.

A new flow sheet with integrated turbine expander is developed and simulated. A plug flow reactor model with reaction kinetics is used. Special attention is given to obtaining realistic values for the various flow sheet parameters as reported in literature sources. By integration of a turbine expander it was possible to change the ethylene process from consuming 1 064 kJ/kg product of energy to delivering 688 kJ/kg product.

Nomenclature

C	Concentration (kmol/m ³)
ΔH_R	Heat of reaction (kJ/mol reactant)
P	Pressure (bar)
Q	Heat (kW)
Q_{COOLER}	Heat removed for cooling (kW)
Q_{HEATER}	Heat added for heating (kW)
Q_{PG}	Heat transferred to the process gas working fluid (kW)
Q_R	Reaction heat (kW)
r	Reaction rate (kmol/(s.m ³))
W_{NET}	Net work produced by or required by a system (kW)
W_{NETSP}	Specific net work produced or required by a system (kJ/kg)
W_T	Total work produced by expanders (kW)
W_C	Total work required by compressors (kW)
W_{SEP}	Work required for separation (kW)

Abbreviations

EO	Ethylene oxide
FC	Feed compressor
PG	Process gas
RC	Recycle compressor
ST	Steam turbine
T	Turbine expander

7.1 Conventional ethylene oxide production process

Ethylene oxide is industrially manufactured by vapour phase oxidation of ethylene on a silver catalyst in a fixed-bed multi-tubular reactor. Nowadays plants capacities exceed 250 000 tonnes/year (Dever et al., 1995).

Two reactions take place in parallel, namely the oxidation of ethylene to ethylene oxide and the oxidation of ethylene to form carbon dioxide and water, which are byproducts:

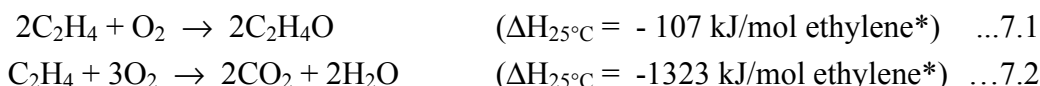

*at 250 °C and 15 bar (Rebsdatt & Mayer, 1991).

A large amount of heat is released by these oxidation reactions. Energy recovery and integration is therefore a prime concern in process design of ethylene oxide plants.

The selectivity increases as conversion decreases. Conversion values are chosen to limit the ethylene oxide concentrations to 1-3 vol% at the reactor outlet (Dever et al., 1995). Typical values of reaction conditions and other variables in the oxygen-based production of ethylene oxide are shown in Table 7.1.

Organic halides, such as ethylene dichloride or vinyl chloride are added to the reactor inlet to inhibit the formation of carbon dioxide. Air or oxygen can be used in the oxidation process. The oxygen process has been shown to be more economical than the process using air (Westerterp & Ptasinski, 1984).

Figure 7.1 shows a flow diagram of a typical production process based on oxygen. Reactants 5 are compressed to the reaction pressure. Methane is added as a diluent gas to raise the flammable limit and reduce the peak temperature difference in the reactor (Dever et al., 1995). The position where methane is introduced to the system varies, it is either added before the feed compressor, as shown in Figure 7.1, or before the recycle compressor (Coombs et al., 1995; Rebsdats & Mayer, 1991). The compressed reactants 6 are delivered to the high pressure recycle loop. The hot reactor product 3 is used to preheat the reactor feed 7.

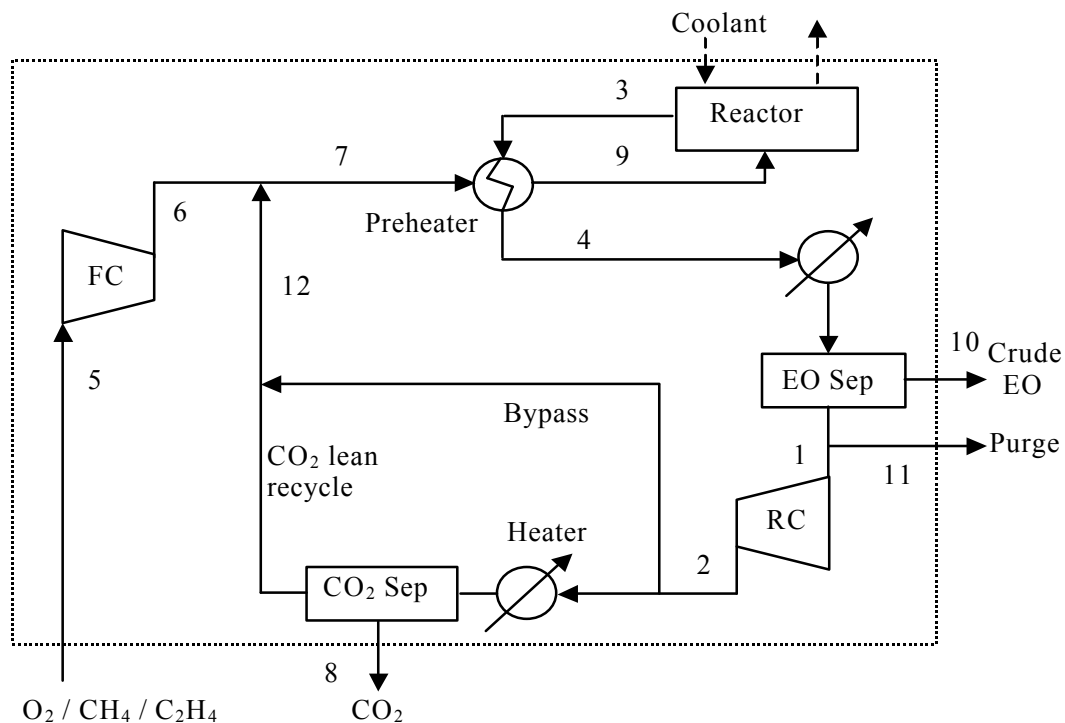

Figure 7.1 Process flow sheet for a conventional ethylene oxide synthesis plant.

Two separation operations are employed within the recycle loop. First, all of the ethylene oxide and small amounts of the other reaction species are absorbed in water (Rebsdats & Mayer, 1991) and removed from the recycle as crude ethylene oxide 10. The final product is recovered from the crude ethylene oxide stream in a desorber and distillation column not

shown in Figure 7.1. In the second separation operation CO₂ is absorbed using a hot potassium carbonate solution. CO₂ absorbers operate at higher pressures compared to the reactor, typically 40 bar and 250°C (Underwood et al., 1997). The recycle is therefore compressed in a recycle compressor before separation of CO₂. A bypass around the CO₂ absorber can be used to limit the size of the unit, as long as the CO₂ concentration in the reactor feed can be kept below 15%. This concentration limit is necessary to avoid the negative influence of high CO₂ concentrations on catalyst activity (Dever et al., 1995).

Table 7.1 Typical values of variables in the oxygen-based production of ethylene oxide.

Variable	Unit	Range / Typical value
Total C ₂ H ₄ conversion (single pass)	%	8-12 ^e 10-12 ^b
Selectivity (mol C ₂ H ₄ O per mol H ₂ O)	mol/mol	75-82 ^e
	%	78-82 ^b
Reaction temperature	°C	200-300 ^a
Reaction pressure	bar	10-30 ^a
Reactor feed gas composition		
C ₂ H ₄	mol %	20-35 ^e
O ₂		4-8 ^e
CO ₂		5-10 (below 15) ^e
CH ₄		1-60 ^a
Ethylene oxide in reactor outlet	mol %	1-3 ^e
Purge rate	%	0.1-0.2 ^a
Reactor geometry		
Number of tubes	-	several thousand ^e
Tube length	m	6-12 ^e
Tube inner diameter	mm	20-50 ^e
Ethylene oxide absorption		
Pressure	bar	7-20 ^c
Temperature	°C	15-50 ^c
CO ₂ absorption		
Pressure	bar	40 ^d
Temperature	°C	250 ^d

a Rebsdatt & Mayer, 1991

b Bingchen et al., 1999

c Cunningham et al., 1971

d Underwood et al., 1997

e Dever et al., 1995

It is well known that ethylene oxide reactors require cooling to prevent reaction runaway and hot spots (Westerterp & Ptasiński, 1984). Cooling can be done using evaporation or circulation of coolant. Heat is extracted more efficiently using evaporation cooling and there are smaller axial temperature differences. The reactor is therefore close to isothermal operation with this type of cooling.

In the case of circulation cooling the axial temperature difference is larger and a temperature increase towards the reactor outlet is obtained. Such a temperature profile compensates for the lower reactant concentrations at the outlet of the reactor that otherwise may lead to uneconomically low conversions (Rebsdatt & Mayer, 1991). Water or a high-boiling hydrocarbon may be used as a coolant.

The reactor typically comprises mild steel or stainless steel tubes with an inside diameter of 20-50 mm and tube lengths of 6-12 m (Dever et al., 1995). The number of tubes are several thousand, Ozero & Landau (1984) for example mentions 10 000 tubes.

7.2 Development of a flow sheet integrated with a turbine expander

The new ethylene oxide flow sheet integrated with a turbine expander is shown in Figure 7.2. This flow sheet was obtained by superimposing the Brayton power cycle onto the conventional flow sheet. The system comprises a high pressure section above the broken line connecting the compressors and turbine, and a low pressure section below this line. The dotted lines are the system boundary and include all of the processing steps that the process gas undergoes to complete a power cycle. The process gas undergoes the processing steps necessary to render a power output, namely compression, heat addition in the reactor, expansion in the turbine expander and heat release in the cooler. The system also includes additional unit operations that are a requirement of the chemical process.

The cooling step preceding separation of crude ethylene oxide satisfies the requirements of the chemical process in terms of separation and the power cycle in terms of heat removal. A synergistic effect is therefore utilised here.

The new flow sheet is now discussed further according to the following flow sheet development impact factors:

Single pass or recycle operation

In the ethylene oxide system with recycle, the integration of a turbine expander results in a semi-closed cycle with a fraction of the working fluid being recycled and reactants and product entering and leaving the system.

Recycle stream separation

Expansion of the reactor product creates two pressure levels within the system. Separation on the lower pressure side, after the expander, has the advantage of decreasing the amount of gas to be recompressed.

Power generation in turbines are favoured by high inlet temperatures and high pressure ratios. The best position in a process for a turbine expander would therefore be at the combination of pressure and temperature that would render the most power when expansion takes place. The pressure and temperature at the outlet of the turbine should also be compatible with the requirements of the downstream unit operations. In the conventional ethylene oxide process, the highest pressure and temperature do not coincide. Conditions at the reactor outlet typically range from 200-300°C and 10-30 bar (see Table 7.1) whilst the carbon dioxide absorber operates at about 250°C and 40 bar. Separation of crude ethylene oxide can be done at 7-20 bar and 15-50°C, as indicated in Table 7.1. It is therefore necessary to increase the operating pressure of the reactor to coincide with that of the carbon dioxide absorber. This modification will make it possible to accommodate the turbine directly behind the reactor and will result in two pressure levels in the recycle loop of the process. The reactor and carbon dioxide absorber units are on the high-pressure side and the ethylene oxide absorber is on the low-pressure side. Such a scheme corresponds more closely to a Brayton power cycle where the pressure ratio for the compressor and turbine are equal. The problem of mixing the high pressure recycle at 40 bar (stream 12 in Figure 7.1) with the low pressure make-up feed at 20 bar (stream 6 in Figure 7.1) is also solved in this way. The pressures and temperatures of the integrated flow sheet are shown in Figure 7.3.

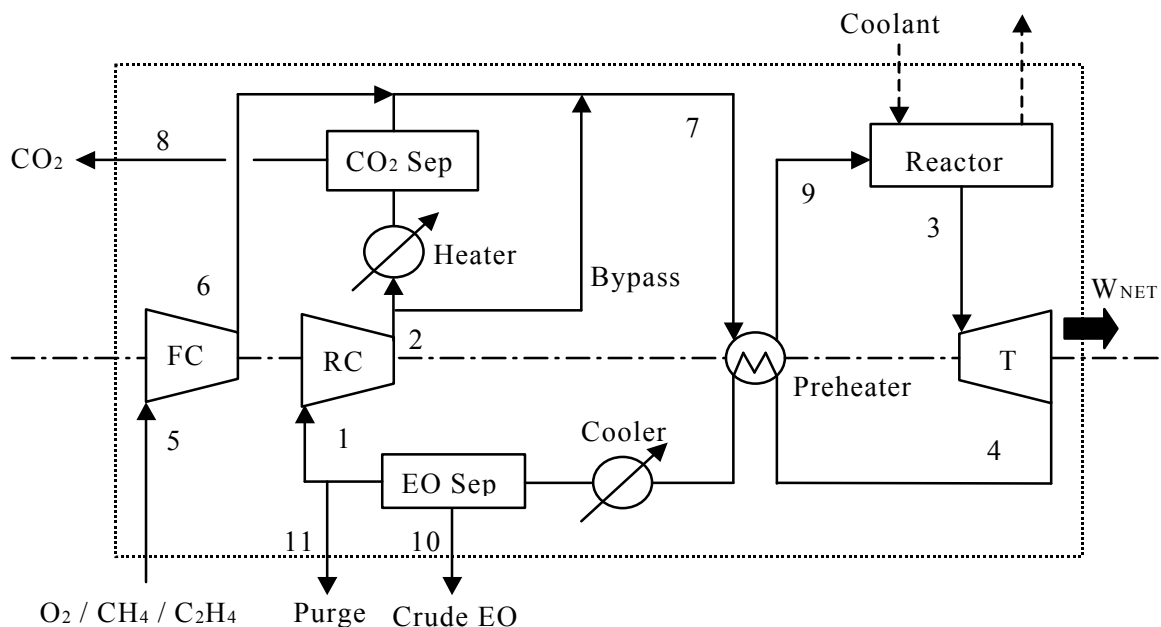

Figure 7.2 Process flow sheet for an ethylene oxide synthesis plant with turbine expander.

Reactor operation

The most favourable case for power production using the process gas would be an adiabatic reactor operation wherein all the reaction heat is absorbed by the process gas to generate power in the process gas cycle. This is however not possible in the case of the ethylene oxide reactor. The alternative is to use a portion of the reaction heat to drive the process gas cycle and the remaining part to generate steam.

The advantage of using the reaction heat to drive the process gas cycle is that the heat is available at the temperature of the reaction, whereas the heat transferred to the steam cycle is lowered in quality due to the temperature driving force.

The ethylene oxide reactor can be allowed to operate with a temperature increase towards the outlet. Such a temperature profile compensates for the lower reactant concentrations at the outlet of the reactor that otherwise may lead to uneconomically low conversions.

The increased reactor pressure of 40 bar is uncommon but there are benefits to it. The increase in pressure will increase the concentrations of the reactants, which in turn increases the reaction rates (Dever et al., 1995). As the reactions take place faster, the reactor length can be shortened to achieve the same conversion. This partially counteracts the increased equipment cost due to the higher pressures.

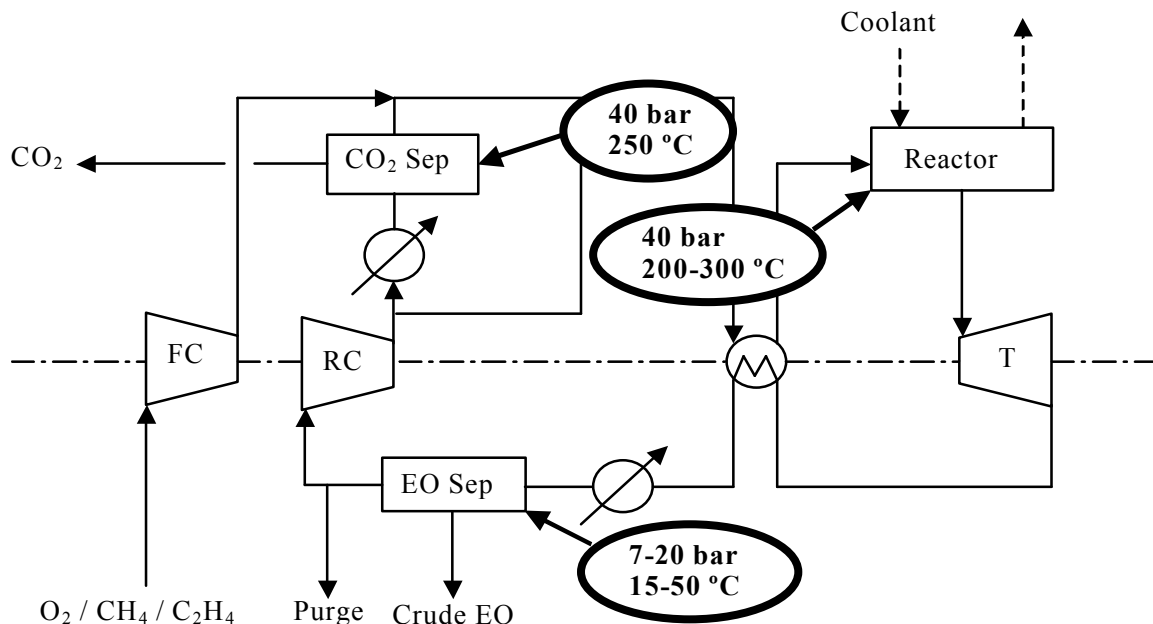

Figure 7.3 Pressure and temperature levels in integrated flow sheet.

Purge gas

Gas is purged from the low pressure side of the system and expansion of the purge gas is therefore not considered.

State of reactants and reactor products

Reactants are in the gas phase and need to be compressed to the higher pressure level of 40 bar before entering the synthesis loop. Products are available at the same conditions as for the conventional process.

Process gas properties

The physical properties of the process gas influence the power production capacity. The methane that is used as a diluent gas also has the function of lowering the temperature and this is negative for power production. However, the added methane also increases the flow rate through the expander, which may benefit the power production.

Volume change during chemical reaction

An increase in volume over the reactor would favour the power production. During the oxidation of ethylene to ethylene oxide 3 moles of gas react to form 2 moles of product causing a decrease in gas volume over the reactor. The extent of the formation of the byproducts and the dilution of the feed gas with methane would determine the real decrease in volume over the reactor.

7.3 Simulation models

Process simulations of the conventional flow sheet and new flow sheet were created in AspenPlus 10.1 using the Soave-Redlich-Kwong method to calculate thermodynamic properties. Steam tables were used for water properties.

The reactor was modelled using a plug flow reactor model. Reaction kinetics was obtained from Westerterp & Ptasiński (1984). These are first-order in oxygen concentration and give the reaction rate per unit mass of catalyst (kmol/s per kg catalyst). For use in the power law kinetic model, the equations were rewritten per unit of reactor volume (kmol/s per m³ reactor volume) using a bulk catalyst density of 850 kg/m³ (Westerterp & Ptasiński, 1984). These equations are:

$$r_{EO} = 59840e^{\frac{-59860.8}{RT}} C_{O_2} \quad ..7.3$$

for the formation of ethylene oxide according to reaction 7.1 and

$$r_{CO_2} = 4.2 \times 10^7 e^{\frac{-89791.2}{RT}} C_{O_2} \quad ..7.4$$

for the complete oxidation of ethylene according to reaction 7.2. The activation energies are in kJ/kmol and the concentrations in kmol/m³.

The reactor was specified to have 10 000 tubes with a 50 mm diameter. This is typical geometry according to the information given in Table 7.1. A design specification was used to vary the tube lengths to obtain an ethylene oxide mole fraction of 1.5±0.5% at the reactor outlet. The tube length needed to satisfy this design specification was 12 m.

In the conventional system a reactor pressure of 25 bar was used and in the new integrated system 40 bar was used, as explained previously.

Detail heat transfer within the reactor was not modelled. A linear temperature increase along the reactor was assumed and specified instead, ranging from 200 to 300°C.

The following information is also relevant to both simulations:

- The steam generated in the reactor is expanded in a steam turbine. The duty of the pump to bring the water to the required pressure is neglected since this is a small fraction (less than 5%) of the compressor duty. Steam at 20 bar is produced and is expanded to 4 bar. The temperature difference between the reactor and the steam is assumed as 20°C in both cases. The flow rate of water is adjusted to render the required temperature for the steam. The water temperature is 40°C.
- Frictional pressure losses through equipment are small compared to the pressure difference over the compression and expansion equipment. Therefore, frictional pressure losses are ignored in both systems.
- Oxidation inhibitors used to retard carbon dioxide formation are omitted from the simulation since they are added in very small amounts.
- An Aspen design specification was used to set the oxygen mole fraction in the reactor feed (see Table 7.1) by adjusting the oxygen flow in the reactant stream 5.
- An Aspen design specification was used to set the methane mole fraction in the reactor feed at 0.5 by adjusting the methane flow in the reactant stream 5.
- The make-up feed or fresh reactants (stream 5) compressor has two stages with intercooling. The intercooling conditions are 10 bar and 50°C in both simulations. An isentropic efficiency of 80% was used for both compressors.
- The recycle compressor is single stage with an isentropic efficiency of 80%.
- A purge rate of 0.2 mol% of the recycle stream was specified.
- CO₂ absorption is done at 40 bar and 250°C. A CO₂ absorber bypass of 60% was specified as to maintain the CO₂ concentration in the reactor feed within acceptable limits (see Table 7.1).

- Ethylene oxide separation is done at 25°C.
- Heat exchangers are modelled using a short-cut method in Aspen Plus whereby any one of a number of parameters may be specified, e.g. cold stream outlet temperature, hot stream outlet temperature or temperature difference on any side.
- Reactants are assumed to be available at 25°C and 1 bar.

The only parameter that is not common to both systems is the turbine expansion pressure in the integrated flow sheet. This pressure also determines the pressure at which the ethylene oxide is separated from the recycle. The expansion pressure may be varied and the amount of power obtained from the system will be dependent on this pressure. However, since the ethylene oxide absorption efficiency would increase with pressure, it will not be acceptable to go below the lower limit 7 bar. The minimum expansion pressure is therefore 7 bar. The turbine expander is modelled using an isentropic efficiency of 80%.

7.4 Results and discussion

It was possible to produce a net amount of work with the integrated flow sheet whereas the conventional flow sheet required external work input. The turbine expansion pressure was varied in the integrated flow sheet to investigate the influence of the expansion pressure on the net work obtained. Figure 7.4 shows the relation between the outlet pressure and the work obtained per kg of pure ethylene oxide product. Note that the product stream is a mixture of ethylene oxide and water, W_{NETSP} is calculated using the ethylene oxide mass fraction of the crude ethylene oxide flow. The maximum work is obtained at an expansion pressure of 18 bar. This corresponds to a pressure ratio of 2.22 across the expander.

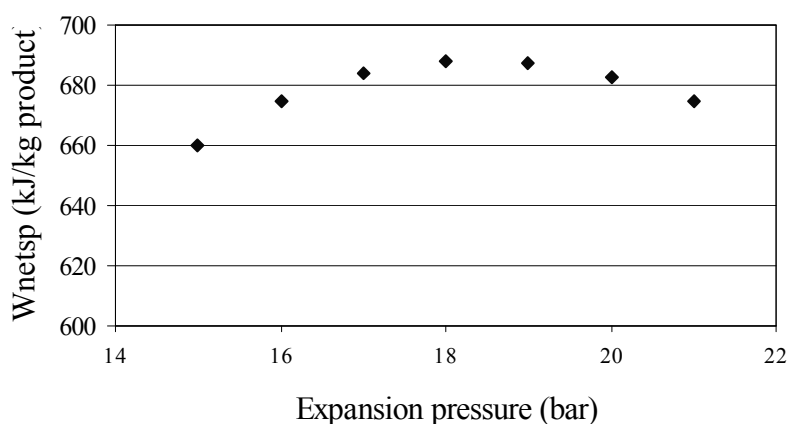

Figure 7.4 W_{NETSP} versus turbine expansion pressure for integrated process.

Except for the duties on the cooler and heater all the parameters in the integrated flow sheet remained constant with change in expansion pressure. It should be remembered that the

temperatures of the CO₂ separation and ethylene oxide separation were kept constant at 250°C and 25°C respectively. The heating and cooling duties varied linearly with expansion pressure, as shown in Figures 7.5 and 7.6. At lower expansion pressures, i.e. at higher pressure ratios across the expander, the temperature at the expander outlet (stream 4) is lower and therefore the cooling duty requirement is also less. At the corresponding higher pressure ratios across the compressor, for a constant inlet temperature, the compressor outlet temperature increases and therefore the heating duty is less. Both the cooling and heating duties are therefore decreased at higher pressure ratios, which has an obvious cost benefit for the heat exchange equipment.

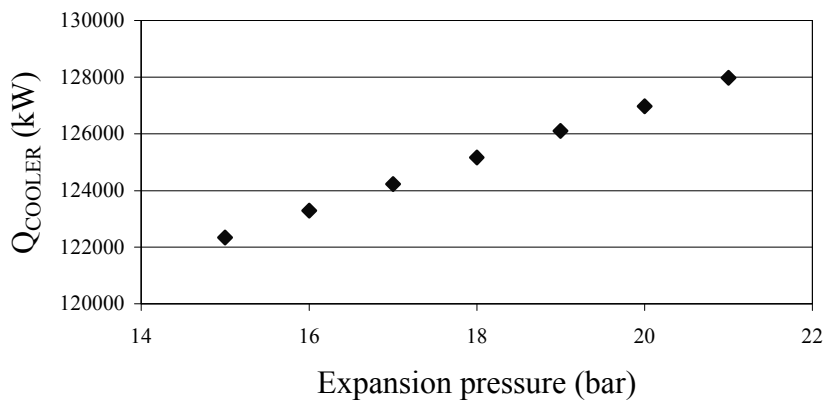

Figure 7.5 Q_{COOLER} versus turbine expansion pressure for integrated process.

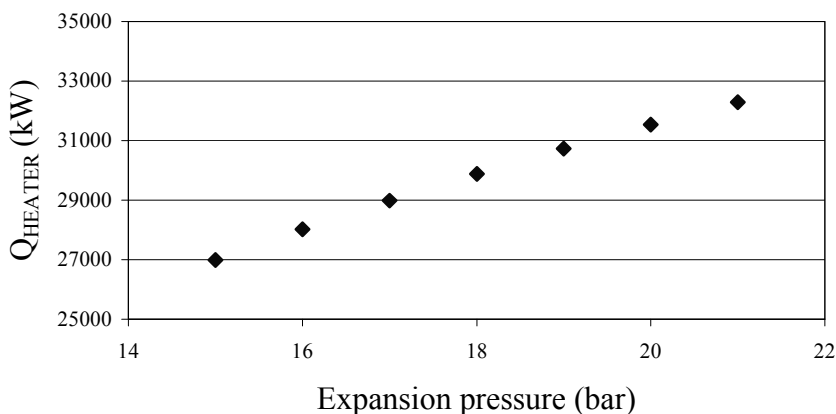

Figure 7.6 Q_{HEATER} versus turbine expansion pressure for integrated process.

Simulation stream results are given in Table 7.2 for the conventional process case and for the integrated process case A, wherein an expansion pressure of 18 bar was specified. Relevant process parameters, heat and work data are given in Table 7.3 for the conventional process and two different integrated processes, A and B. Note that the work and heat terms are expressed per kg of ethylene oxide produced to enable comparison of the cases on the same basis. Integrated process A will first be compared to the conventional process before integrated process B is discussed.

The conversion in integrated process A is higher due to the higher reactor pressure. Corresponding to the higher conversion, an increase in reaction heat and power generated using steam is observed. The lower selectivity also contributes to the increase in reaction heat, due to the formation of CO₂ that is much more exothermic compared to the formation of ethylene oxide.

Table 7.2 Simulation stream results (stream numbers correspond to Figure 7.1 for the conventional process and Figure 7.2 for the integrated process)

No.	Stream Name	Integrated Process A				Conventional Process			
		n kmol/s	m ton/h	P bar	T °C	n kmol/s	m ton/h	P bar	T °C
1	RC in	12.72	1091	18	25	11.13	945	25	25
2	RC out	12.72	1091	40	94	11.13	945	40	66
3	Reactor out	13.68	1186	40	300	11.87	1019	25	280
4		13.68	1186	18	192	11.87	1019	25	205
5	FC in	1.59	170	1	25	1.20	127	1	25
6	FC out	1.59	170	40	191	1.20	127	25	140
7		13.84	1186	40	145	11.99	1019	25	118
8		0.47	327	40	250	0.34	54	40	250
9	Reactor in	13.84	1186	40	200	11.99	1019	25	200
10	Crude EO	0.94	93	18	25	0.71	72	25	25
11	Purge	0.03	2	18	25	0.022	2	25	25

More work is needed to compress the feed gas as well as recycle gas to the higher reactor pressure of 40 bar. However, the turbine expander is able to provide more work than what is required for the recycle compressor. The work required to compress the process gas (W_{PG}) has decreased from 2 803 to 1 197 kJ/kg EO. The integrated process A has a net power output of 688 kJ/kg EO compared to the conventional process that requires 1 064 kJ/kg EO of power.

The integrated case B was simulated to investigate changes in selectivity. Case B has a higher selectivity than case A. The reaction to form CO₂ and water has a heat of reaction that is in the order of twelve times that of the reaction to form ethylene oxide. More reaction heat will

be produced at lower selectivities (mol C₂H₄O per mol H₂O), corresponding to an increase in steam production and power resulting from a steam cycle. The simulation results in Table 7.3 show that W_{PG} are similar for case A and B, however, 13% more work is obtained from steam in case A.

Temperature also influences the reaction rates. In Figure 7.7 the ratio of the reaction rates for ethylene oxide formation and CO₂ and water formation are plotted against temperature. At about 280 °C the rates are equal, above this temperature CO₂ starts to form at a higher rate. In order to increase the selectivity for integrated case B, the reactor linear temperature profile was changed to 200-280 °C, in stead of 200-300 °C. Conversion remained the same as for case A, but selectivity increased from 68.6% to 80%.

Table 7.3 Process parameters, heat and work.

Process	Integrated A	Integrated B	Conventional
Parameter	Process related information		
Total single pass C ₂ H ₄ conversion, %	12.1	12.0	10.4
Selectivity, mol/mol %	68.5	80.0	74.9
Reactor pressure, bar	40	40	25
Linear reactor temperature increase, °C	200-300	200-280	200-300
Reactor feed gas, mol fraction			
C ₂ H ₄	0.337	0.344	0.343
O ₂	0.070	0.070	0.080
CO ₂	0.092	0.084	0.076
CH ₄	0.500	0.500	0.500
EO in reactor outlet, mol fraction	0.025	0.026	0.022
Crude EO flow rate, kg/h	93 262	71 957	71 869
EO in crude EO, mass fraction	0.542	0.576	0.554
Pure EO produced, kg/h	50 576	41 453	39 795
Process	Integrated A	Integrated B	Conventional
Parameter	Heat and Work	kJ/kg EO produced	
W _{FC}	1 663	1 504	1 372
W _{RC}	2 311	2 145	1 430
W _T	-2 777	-2 476	-
W _{PG}	1 197	1 173	2 803
W _{ST}	-1 885	-1 675	-1 738
W _{NET}	-688	-502	1 064
Q _R	-20 217	-18 297	-18 985
Q _{COOLER}	-8 909	-7 242	-10 390
Q _{HEATER}	2 127	1 976	2 757

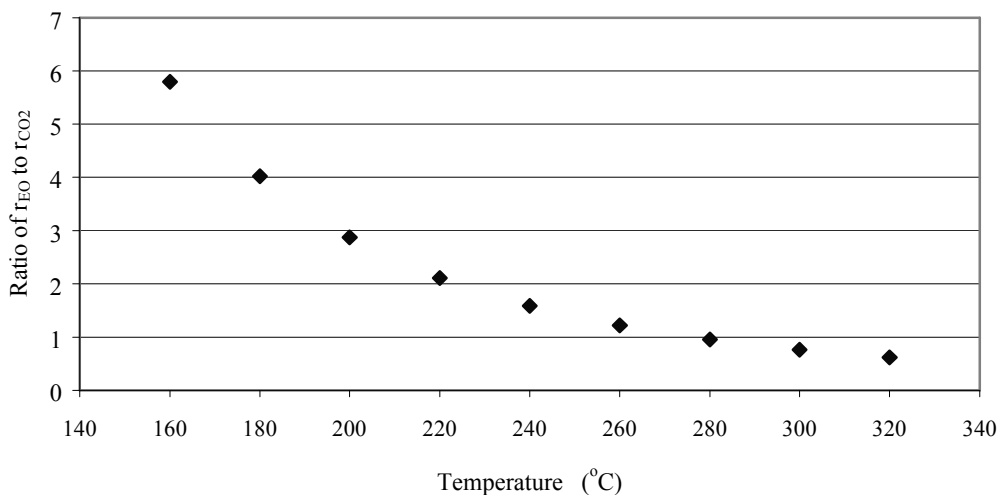

Figure 7.7 Ratio of reaction rates, r_{EO}/r_{CO_2} versus reactor temperature.

7.5 Conclusions

An ethylene oxide synthesis flow sheet was developed that makes use of process gas to produce power together with the conventional steam power production. By increasing the reactor operating pressure, a turbine expander could be accommodated in the existing flow sheet. Since the linear temperature profile across the ethylene oxide reactor was fixed, a decrease in selectivity led to increased steam production due to the highly exothermic nature of the formation of the byproducts CO_2 and water.

By integration of a turbine expander it was possible to change the ethylene process from consuming 1 064 kJ/kg EO of energy to delivering 688 kJ/kg EO. Since there are many parameters that are interdependent in the simulated EO flow sheets, it is most likely impossible to find an optimum set of parameters, there may be more than one set of conditions that will render a good design.

7.6 References

Bingchen Z, Yuanshun W and Hongshi W, “Modelling catalytic reaction-absorption coupling process of ethylene oxide synthesis in slurry reactor”, *Chemical Engineering Science*, vol. 54, pp. 1531-1534, 1999.

Coombs J, Kim D and Palombo L, “Celanese Clearlake ethylene oxide reactor revamp”, 1997, <http://www.owl.net.rice.edu/~ceng403/ethox97.html>, accessed August 2002.

Cunningham JW, Foster EG and Vanderwater RG, "Secondary removal of inerts in ethylene oxide purification", *US Patent 3766714*, assigned to Shell Oil Company, US, 1971.

Dever JP, George KF, Hoffman WC and Soo H, "Ethylene oxide" in: Kroschwitz JI (Executive Editor), *Kirk Othmer Encyclopaedia of Chemical Technology*, 4th Edition, vol. 9, pp. 915-959, John Wiley and Sons, New York, 1995.

Ozero BJ and Landau R, "Ethylene oxide" in: McKetta, J. J. (executive editor), *Encyclopedia of Chemical Processing and Design - 20, Ethanol as fuel; options, advantages and disadvantages to exhaust stacks, cost*, Dekker Publishing, New York, 1984.

Rebsdatt S and Mayer D, "Ethylene oxide" in: Gerhartz, W (Executive Editor), *Ullman's Encyclopaedia of Industrial Chemistry*, A10, pp. 117-126, VCR Vertrieb Publishers, Dusseldorf, Germany, 1991.

Underwood J, Dawson G and Barney C, "Design of a CO₂ absorption system in an ammonia plant", 1997, <http://www.owl.net.rice.edu/~ceng403/co2abs.html>, accessed August 2002.

Westerterp KR and Ptasinski KJ, "Safe design of cooled tubular reactors for exothermic, multiple reactions; parallel reactions-II The design and operation of an ethylene oxide reactor", *Chemical Engineering Science*, vol. 39, no. 2, pp. 245-252, 1984.

Chapter 8

Expansion of synthesis gas to produce power

Synthesis gas production provides an excellent opportunity for integration of a turbine expander since the heat is available at very high temperatures (900-1400 °C). This case study considers the integration of a turbine expander with a conventional synthesis gas production process that uses autothermal reforming. For the purposes of the case study a system similar to one described in a recent patent (Agee et al., 2000), wherein the synthesis gas is fed to a Fischer-Tropsch reactor, is used.

This case study has the following unique features:

- *Heat is available at a considerably higher temperature compared to the previous studies which means that the potential for improved heat recovery is also higher.*
- *Integration of a turbine expander into the conventional process renders a unique combined cycle arrangement comprising a process gas topping cycle and a steam bottoming cycle.*

At an expansion pressure of 5 bar it is possible to produce 41% more work by using a turbine expander compared to the conventional synthesis gas production system where only a steam cycle is utilised.

Nomenclature

Q_C	Heat transferred to a cold reservoir (kW)
$Q_{CONDENSE}$	Heat removed in condenser (kW)
Q_H	Heat received from a hot reservoir (kW)
Q_{IN}	Heat input to a heat engine/power cycle (kW)
Q_{OUT}	Heat removed from a heat engine/power cycle (kW)
Q_{PG}	Portion of reaction heat absorbed by the process gas (kW)
Q_{ST}	Portion of reaction heat transferred to generate steam (kW)
W_C	Compressor power (kW)
W_{NET}	Net power delivered or required by a system (kW)
W_{PG}	Power delivered using process gas (kW)
W_{PUMP}	Work required by a pump (kW)
W_{ST}	Power delivered by a steam cycle (kW)
W_T	Expander power (kW)

Abbreviations

ATR	Autothermal reforming	HP	High pressure
BFW	Boiler feed water	POX	Partial oxidation
C	Compressor	SMR	Steam methane reforming
FT	Fischer -Tropsch	ST	Steam Turbine
GTL	Gas to liquids	T	Turbine
HER	Heat exchange reforming		

8.1 Synthesis gas generation for natural gas conversion

Production of synthesis gas (syngas) is the first step in most commercial technologies for converting natural gas into chemicals and fuels. The syngas production step also accounts for more than 50% of the capital investment for typical gas-to-liquids (GTL) complexes. Therefore, the improvement of syngas production processes and exploration of new production routes are of great interest (Wilhelm et al., 2001; Aasberg-Petersen et al., 2001).

Synthesis gas is produced by either catalytic steam reforming, partial oxidation or some combination of these routes. Steam methane reforming (SMR) is the most common and well-known technology. In SMR the steam and methane are endothermically converted to CO and H₂. Heat for the endothermic reactions is externally supplied by combustion of fuel in a furnace. In partial oxidation methane is exothermically reacted with oxygen to form CO and H₂. Partial oxidation can be carried out in two ways. Non-catalytic partial oxidation (POX) needs high temperatures for complete conversion and soot reduction. Catalytic partial

oxidation (CPO) uses a catalytic reactor without a burner. However, commercial application of CPO has not been realised yet.

SMR and POX produce syngas with very different compositions. SMR produces a syngas with an H₂/CO ratio of 3 whereas in POX the ratio is 1.7-1.8. The required H₂/CO ratio varies with the synthesis in question. The final composition of the syngas from SMR and POX can be manipulated to some extent by altering process conditions or adding some process steps. However, even with manipulation neither SMR nor POX is ideal for GTL applications. Fischer-Tropsch synthesis requires an H₂/CO ratio of about 2. To overcome this problem SMR and POX are used together, either in parallel or combined into one reactor, a technology known as autothermal reforming (ATR). In ATR the heat required for the endothermic steam reactions is supplied by the oxidation of a portion of the feed. The ATR reactor consists of a burner, combustion chamber and catalyst bed placed in a refractory lined pressure vessel. The feed is reacted with a mixture of oxygen and steam in a substoichiometric flame before entering the catalyst bed.

Apart from its compatibility with Fischer-Tropsch synthesis, several other factors, such as compactness, lower capital cost and potential for economies of scale, makes ATR an attractive technology for incorporation into GTL complexes (Wilhelm et al., 2001; Aasberg-Petersen et al., 2001).

8.2 Utilisation of high temperature heat from synthesis gas

Synthesis gas production provides an excellent opportunity for integration of a turbine expander since almost all the technologies involve heat recovery from high temperature product gases. This high temperature heat can be utilised more efficiently by expanding the gas to produce power. The temperature of synthesis gas produced by the different technologies range from about 900 °C for SMR up to 1 400 °C in the case of POX (Hinderink et al., 1996). The synthesis gas needs to be cooled down considerably to separate condensates and accommodate the temperature requirements of downstream processes. Using the hot synthesis gas for generation of steam entails large temperature driving forces associated with large exergy losses. If the temperature of the generated steam is increased by superheating the steam the exergy loss can be decreased to some extent.

In conventional steam reforming a major drawback is that only 50-60% of the fired energy from the reformer furnace is actually transferred to the process. The remaining energy is used to generate high pressure steam or to preheat feed streams (Aasberg-Petersen et al., 2001; Hinderink et al., 1996). One way to improve this situation is by using a *heat exchange reformer* in which process gas that flows through the catalyst bed is heated with flue gas as well as hot product gas leaving the reactor.

Heat exchange reforming (HER) can also be applied in process schemes where the outlet gas from an ATR unit is used as a heat source for a steam reforming unit. The high temperature heat is certainly utilised more efficiently in heat exchange reforming. Temperature driving forces for cooling of the product to generate steam will also be lower. The concept is shown in Figure 8.1.

Hinderink et al. (1996) compared a number of synthesis gas production processes based on exergy analysis for methanol production. One of the systems in this comparison was a convective reformer in combination with partial oxidation. The convective reformer is a heat exchange reformer and the product from the POX is the heat source in this case, similar to the parallel system in Figure 8.1, but with POX replacing ATR. Compared to conventional steam reforming, giving an overall exergy loss of 8.5 GJ/tonne methanol, this option had an exergy loss of only 4.9 GJ/tonne methanol. Among others, the following important conclusions resulted from the exergy analysis:

- Processes in which uncontrolled combustion is reduced, i.e. where furnaces are decreased or eliminated show a large improvement with respect to exergy utilisation.
- Besides losses due to chemical irreversibilities, *heat recovery is the second largest exergy consuming step.*

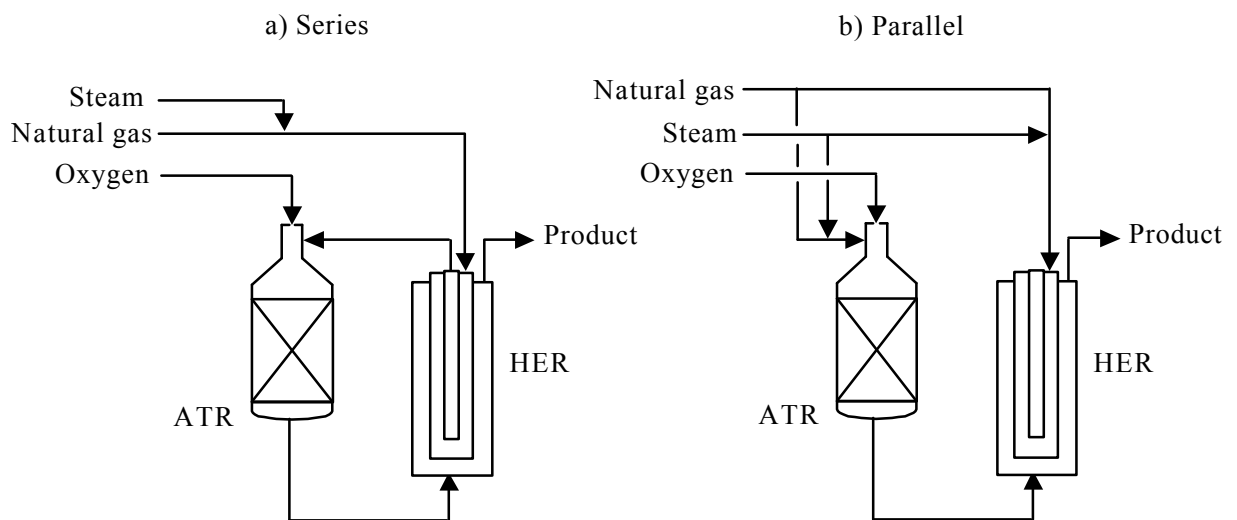

Figure 8.1 Heat exchange reforming using ATR outlet gas as a heat source: a) series b) parallel (Aasberg-Petersen et al., 2001).

Although heat exchange reforming provides a way of reducing exergy losses it is believed that expansion of the hot synthesis gas is another way to reduce these losses. The patent of Agee et al. (2000), referred to in Chapter 2, is an example of an ATR integrated with an expansion turbine. In this patent a system is described wherein the ATR produces synthesis gas and serves as the combustor for the gas turbine. The synthesis gas may be used as a feedstock for a

Fischer-Tropsch (FT) reactor, methanol or ammonia reactor. Figure 8.2 illustrates this concept with a Fischer-Tropsch reactor. The gas turbine referred to in the patent includes an air/O₂ compressor and an expander as a distinct power generation system and run on a single shaft. The power generation system or *heat engine* is indicated by the dotted line. After expansion in the turbine, the gas is cooled and condensate is removed in a separator. Recompression of the synthesis gas will be needed before entering the FT section.

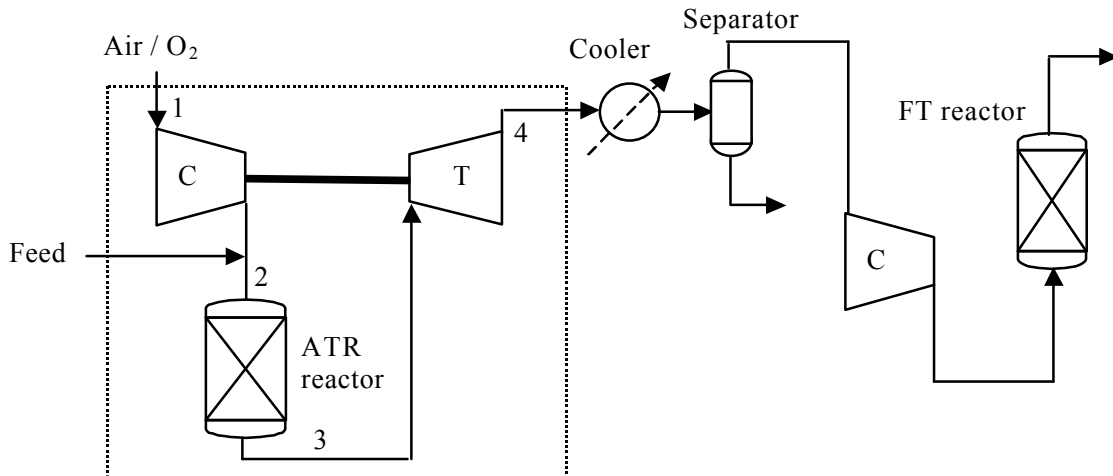

Figure 8.2 System patented by Agee et al. (2000).

A concern with this system proposed by Agee et al. (2000) is that from a safety point of view the placement of an oxygen compressor in close proximity to the ATR reactor may not be desirable. The oxygen will be produced in a separate air separation plant and will be available at the desired pressure from that specific unit. Usually electrical motors or steam turbines will be used to drive the air compressors in the air separation unit.

Although the patent by Agee et al. (2000) only refers to ATR technology, the same scheme can also be applied for POX. In fact, since the POX outlet temperature is higher it should be more beneficial for power generation.

8.3 Retrofitting a conventional ATR process scheme with a turbine expander

For the purposes of this case study it was decided to look at retrofitting an existing design of an ATR process scheme with a turbine expander. This means that no changes are allowed to the ATR reactor or the downstream reactor where the synthesis gas is processed further. A conventional case is defined for comparison to the new case with a turbine expander. A system similar to the one described in the patent by Agee et al. (2000), wherein the synthesis gas is fed to an FT reactor, is used. However, it is assumed that oxygen is available at the

required pressure from an oxygen plant and therefore only the expansion and recompression of the synthesis gas is considered, with the option of running this expander and compressor on one shaft. The conventional flow sheet is shown in Figure 8.3. The hot synthesis gas is first used to generate steam and is then cooled further before condensate is removed. The dry synthesis gas is heated to the required temperature of the FT reactor. The flow sheet with turbine expander and compressor is shown in Figure 8.4.

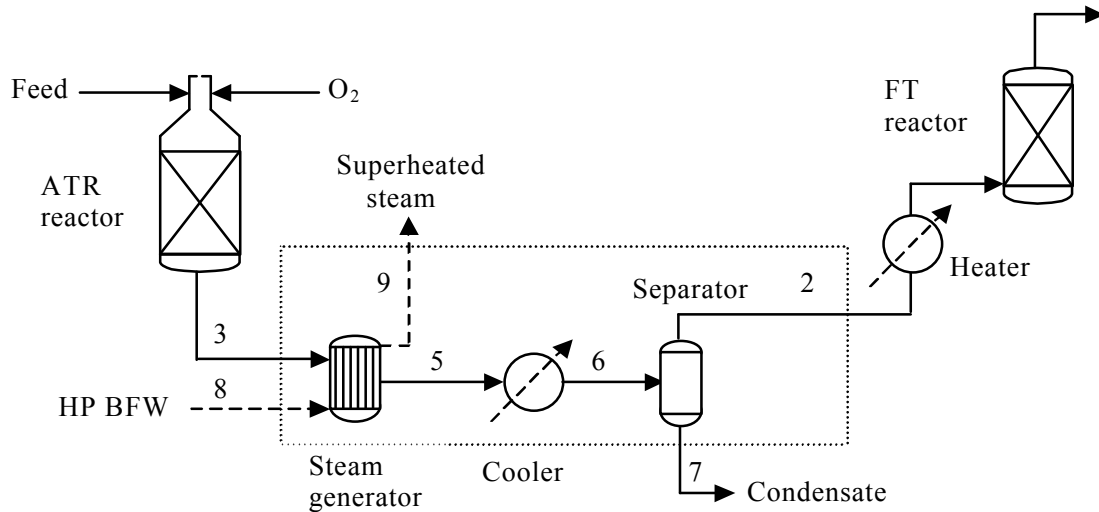

Figure 8.3 Basic ATR process scheme.

Integration of the turbine expander into the conventional flow sheet is based on the novel approach presented in Chapter 3 as follows:

- Analogous power production cycle structure*

The system enclosed by the dotted line boundaries in Figure 8.4 includes all the steps required for power production, but just not in the same order as for a conventional open Brayton cycle. Figure 8.5 shows a closed Brayton cycle. Usually the cycle is open between points 1 and 4. The cycle in the current case is open between points 2 and 3. The same stream numbering have been used in Figure 8.4 to show the states of the working fluid as it proceeds through the different steps in the cycle.
- Utilisation of synergistic effects*

Cooling and condensate separation takes place on the low pressure side of the integrated system in Figure 8.4. This positioning of the separation operation has two advantages. First, the removal of condensate before recompressing the syngas reduces the compression requirements. The condensate is pumped and this requires less energy compared to compressing a gas. Secondly, there is synergy in the sense that cooling is a requirement for the power cycle as well as for the process separation.

- *Definition of appropriate system boundaries*

A system boundary for the Brayton power cycle using syngas is shown using dotted lines in Figure 8.4. The dotted lines in Figure 8.3 show the system boundary for comparison to the conventional process. Note that the heater for preheating the dry synthesis gas is excluded from the systems to simplify the analysis. Either external heat or FT product-feed preheating may be used for this heating step. The steam cycle that uses the superheated steam to produce power is considered as a separate system that receives heat from the syngas power cycle. The two power cycles can be considered together as a special kind of combined cycle that comprises a process gas topping cycle and a steam bottoming cycle. Figure 8.6 gives a heat engine representation of the combined cycles.

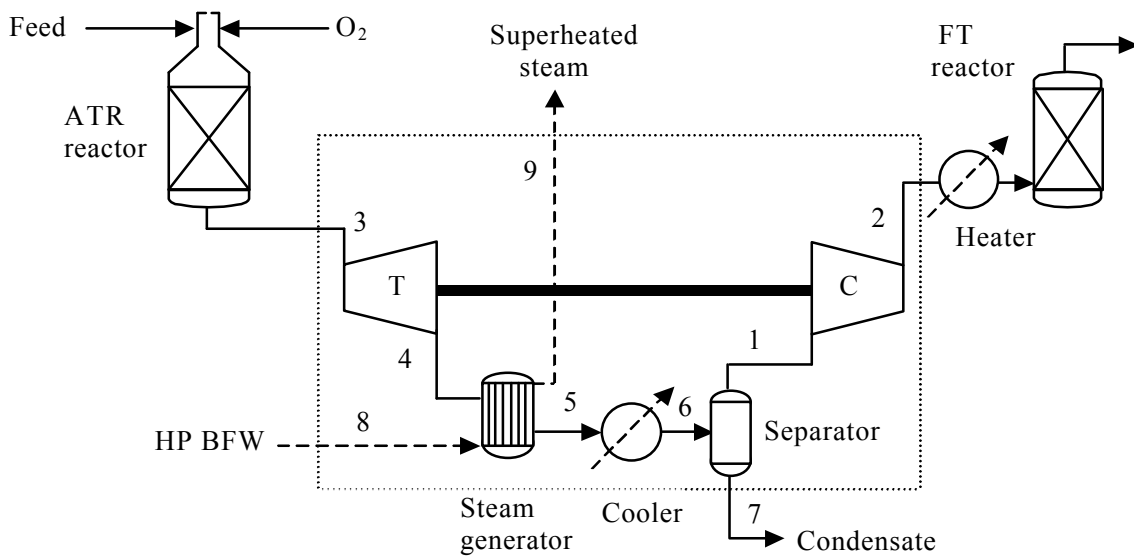

Figure 8.4 ATR process scheme with turbine expander.

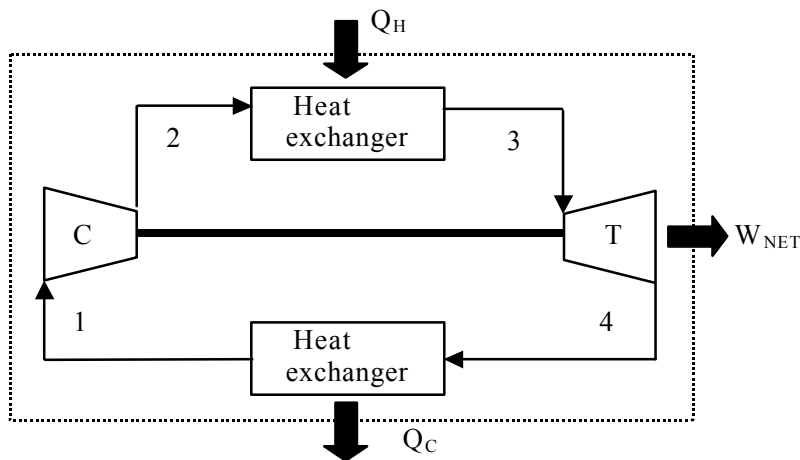

Figure 8.5 Components of a closed Brayton cycle power plant.

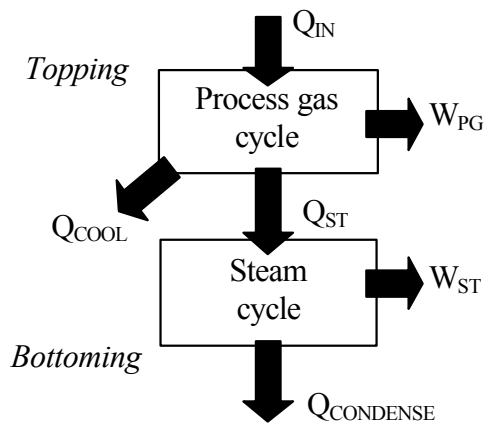

Figure 8.6 Heat engine representation of *combined process gas and steam cycle*.

8.4 Simulation models

Process simulations of the conventional flow sheet and new flow sheet were created in AspenPlus 10.1 using the Soave-Redlich-Kwong method to calculate thermodynamic properties. Steam tables were used for water properties.

Process conditions at the outlet of the ATR are obtained from the work done by Venter (2002). Venter (2002) simulated a gas-to-liquids process including an ATR and a low temperature slurry bed Fischer-Tropsch reactor. The ATR is operated at a pressure of 24 bar and the temperature of the outlet gas is 975 °C. The corresponding synthesis gas composition (mole fraction) obtained from Venter (2000) is as follows:

H ₂ O	0.30
H ₂	0.39
CO	0.18
CO ₂	0.08
N ₂	0.05

The following assumptions are also made:

- HP pressure boiler feed water (HPBFW) is available at 48 bar and 120 °C.
- Superheated steam at 40 bar and 450 °C is generated in the steam generator.
- The synthesis gas is cooled to 50 °C before condensate is separated.
- The condensate is pumped to 48 bar.
- The FT reactor operates at 24 bar and 260 °C (Venter, 2002). The dry synthesis gas is heated to 260 °C before entering the FT reactor.

- The turbine expander and compressor are single stage and have isentropic efficiencies of 80%.
- The pressure loss of the synthesis gas through the cooler and separator is negligible compared to the pressure difference across the expander and compressor.
- The synthesis gas is cooled to 150 °C in the steam generator.
- The superheated steam is expanded to 1 bar in a condensing steam turbine to generate power. Isentropic efficiency of the steam turbine is 80%.

8.5 Simulation results and discussion

The expansion pressure was varied for the integrated flow sheet. Figure 8.7 shows how the net work increases as the expansion pressure is decreased. The solid line shows the net work for the conventional process.

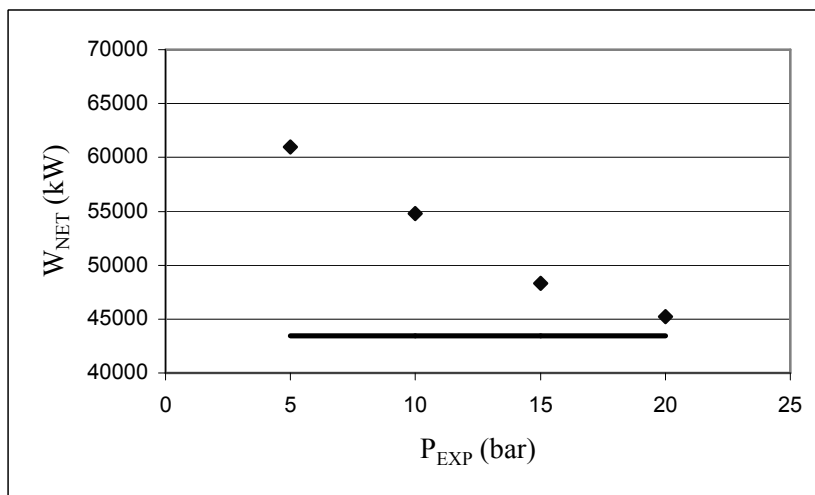

Figure 8.7 W_{NET} versus P_{EXP}

Table 8.1 shows the simulation stream results for comparison of the conventional and integrated flow sheets. The 5 bar expansion pressure case was chosen for comparison. For this case the integrated flow sheet delivers 41% more work compared to the conventional system.

Also note that preheating of the syngas is not needed in the integrated case since the gas leaves the compressor at a temperature of 263 °C, which is suitable for the FT reactor. In the conventional case the syngas is at 50 °C.

Table 8.1 Mass and energy balance results (stream numbers correspond to Figure 8.3 for the conventional process and Figure 8.4 for the integrated process)

Stream		Integrated Process $P_{EXP} = 5 \text{ bar}$			Conventional Process		
No.	Name	m ton/h	P bar	T °C	m ton/h	P bar	T °C
1	Compressor inlet	240	5	50	-	-	-
2	Compressor outlet	240	24	263	235	24	50
3	Hot syngas	350	24	975	350	24	975
4	Expander outlet	350	5	678	-	-	-
5		350	5	150	350	24	150
6		350	5	50	350	24	50
7	Condensate	110	5	50	116	24	50
8	HP BFW	137	48	120	254	48	120
9	Steam	137	40	450	254	40	450
Parameter		Work and heat streams (kW)					
	W_C			28521			-
	W_T			-66202			-
	W_{PUMP}			177			104
	W_{PG}			-37504			-
	Q_{COOL}			-91549			-70391
	Q_{ST}			107803			199243
	W_{ST}			-23493			-43420
	W_{NET}			-60997			-43316

8.6 Conclusions

A turbine expander was integrated into a synthesis gas production process that uses autothermal reforming. The available heat from the hot syngas is used to produce power in a combined cycle comprising a process gas topping cycle and a steam bottoming cycle. The net work available from this integrated system increases with an increase in pressure ratio across the expander. At an expansion pressure of 5 bar it is possible to produce 41% more work compared to the conventional system where only a steam cycle is utilised.

8.7 References

Aasberg-Petersen K, Bak Hansen J-H, Christensen TS and Dybkjaer I, "Technologies for large-scale gas conversion", *Applied Catalysis A: General*, vol. 221, pp.379-387, 2001.

Agee MA, Weick LJ, Agee KL and Trepper EL, “Synthesis gas production system and method”, *US Patent 6155039*, assigned to Syntroleum Corp (US), 2000.

Hinderink AP, Kerkhof FPJM, Lie ABK, De Swaan Arons J and van der Kooi HJ, “Exergy analysis with a flowsheeting simulator – II. Application: Synthesis gas production from natural gas”, *Chemical Engineering Science*, vol. 51, no. 20, pp. 4701-4715, 1996.

Venter JA, “Modelling and exergy analysis of the natural gas to hydrocarbon liquids (GTL) process”, *Master of Engineering Thesis*, University of Pretoria, 2002.

Wilhelm DJ, Simbeck DR, Karp AD and Dickenson RL, “Syngas production for gas-to-liquids applications: technologies, issues and outlook”, *Fuel Processing Technology*, vol. 71, pp. 139-148, 2001.

Chapter 9

Using turbine expanders to recover exothermic reaction heat – flow sheet development for typical chemical processes*

The integration of a turbine expander into different types of high pressure, exothermic chemical synthesis processes is considered. In conventional systems the reaction heat is often transferred to generate steam to drive steam turbines or used for heat integration. The heat is reduced in quality due to the temperature driving forces in the heat exchange equipment. Reaction heat can be utilised at the maximum possible temperature by placing a turbine expander directly after the reactor. The power generated from such combined power and chemical systems can either be exported or used to satisfy the process compressor requirements. A methodology is presented to lend structure to the development and analysis of the flow sheets for the mentioned systems. The methodology involves the consideration of various factors that were identified to impact on the flow sheet development. These factors are discussed and a brief overview of the flow sheet development for four different case studies is given. Process data generated from simulations are used.

* Submitted to: *Energy – The International Journal* in 2002.

Nomenclature

P_{EXP}	Expansion pressure (bar)
Q_{IN}	Heat input to a heat engine (kW)
Q_{OUT}	Waste heat dumped from a heat engine (kW)
Q_{COOL}	Heat removed during cooling (kW)
W_C	Work of compression (kW)
W_{NET}	Net work delivered or required by a system (kW)
W_{NETSP}	Net work delivered or required per kg product (kJ/kg)
W_{REF}	Work required for refrigeration (kW)
W_{TC}	Sum of compression and expansion work for process gas (kW)
W_{ST}	Work obtained from a steam cycle (kW)
x	Single pass conversion (mol %)

Flow sheet abbreviations

BFW	Boiler feed water
C	Compressor
Cool	Cooling
CW	Cooling water
EO	Ethylene oxide
HX	Heat exchanger
Sep	Separation
T	Turbine expander

9.1 Introduction

Turbine expanders are high efficiency turbines that specifically exclude steam and combustion gas turbines. Today turbine expanders are mostly used in air-separation to expand down from 5 bar and in hydrocarbon processing plants to expand natural gas from as high as 200 bar. Most of the hydrocarbon gas expanders are designed for power recovery and are directly connected to a process compressor on the same shaft. Power recovery applications are on the increase mainly due to a change in market conditions driven by growing environmental awareness and an increase in power costs (Bloch, 2001a; Bloch, 2001b).

A wide range of turbine expander models is available, ranging from 75 kW to 10 MW and even up to 130 MW (Bloch, 2001a; Dresser-Rand, 2001). Temperatures up to 870 °C can be accommodated (Dresser-Rand, 2001). Typical isentropic efficiencies range from 84 to 86%

(Bloch, 2001b). Moreover the machines have also demonstrated a high degree of reliability (Bloch, 2001a).

In this work chemical reaction systems wherein turbine expanders are used to recover exothermic reaction heat are considered. Direct expansion of the hot, high pressure product gas is a more efficient way of heat recovery compared to conventional steam raising systems. However, the development of flow sheet configurations for such integrated systems proves to be challenging in the sense that many factors have to be taken into consideration. These factors relate to the requirements for the chemical process and requirements of the power cycle created using the process gas.

9.2 Methodology for developing and analysing the flow sheets of integrated systems

The basis for the flow sheet design methodology is a novel approach to combining chemical reaction and power production systems. This novel approach involves the following aspects:

Realisation of analogies

The analogy between a chemical reaction system with expansion turbine and a conventional power generation cycle is realised. Chemical reaction-power production cycle flow sheets are structured analogous to power production cycles. A power cycle includes a number of crucial processing steps necessary to render a net power output. As a minimum requirement the process working fluid should undergo the same processing steps as the working fluid of a conventional power cycle to make power production possible. The system should however still be able to produce the chemical product.

Utilisation of synergistic effects

Synergistic effects are identified and used to improve the flow sheet. These are process steps that are a requirement for power production and the chemical process and that may be combined to decrease the number of unit operations in the final integrated flow sheet.

Definition of appropriate system boundaries

Systems instead of single unit operations are considered. A system is defined as a number of unit operations that are grouped and operated together and have a common purpose. Unit

operations are grouped to form appropriate and sensible systems for analysis and optimisation.

The methodology comprises the consideration of a number of factors that was identified as typical process characteristics influencing the structure of the combined chemicals and power production flow sheets. These process characteristics are referred to as *impact factors*. Two kinds of impact factors were identified, namely *general impact factors*, or those that were relevant in all the processes, and *specific impact factors* or those that were very specific characteristics of one single process.

The information about the chemical reaction process to be combined with a turbine expander is organised by listing the general impact factors and assigning relevant process information to each factor. Important requirements of the chemical process, that can not be assigned to any of the general factors, are listed separately as specific impact factors.

The development of the integrated flow sheet requires an understanding of the requirements of the chemical and power production process as well as the role of the general impact factors. A discussion of these requirements and general impact factors in the next sections aims to assist in the development of such an understanding.

Once a flow sheet configuration or base case has been determined a *flow sheet analysis* is needed to find a suitable set of flow sheet conditions. Many *flow sheet parameters* may influence the power and chemicals production within the flow sheet, such parameters should be identified and varied within acceptable limits during flow sheet analysis. In the brief overview of the case studies presented here, reference is made to the relevant parameters as a guide. The methodology is summarised in Figure 9.1.

9.3 Gas power cycles and chemical reactions systems

Since the flow sheet of an integrated system has the dual purpose of power and chemicals production, the requirements for producing these products separately is first considered.

The power cycle used in the development of the integrated flow sheets is the Brayton cycle, shown in Figure 9.2. This cycle can be operated as a *closed cycle*, utilising heat transfer processes, or as an *open cycle* utilising an internal-combustion process. Thermal efficiency of the cycle depends on the pressure ratio and specific heat ratio. The work of compression or expansion depends on the pressure ratio, specific heat ratio and inlet temperature of the

compressor or turbine. Therefore a low compressor inlet temperature and high turbine inlet temperature are needed to ensure that the net work developed is sufficient (Moran & Shapiro, 1995). The dotted lines in Figure 9.2 shows the boundaries for presenting the Brayton cycle as a heat engine with heat source, waste heat and net work delivered.

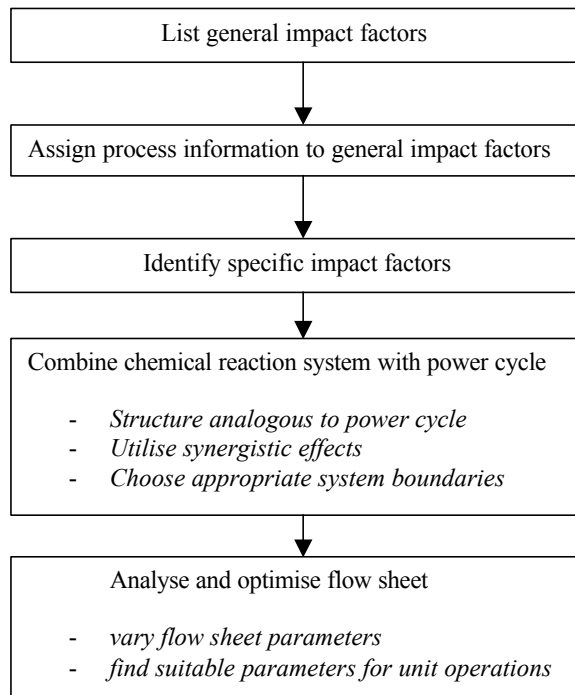

Figure 9.1 Summary of flow sheet design methodology.

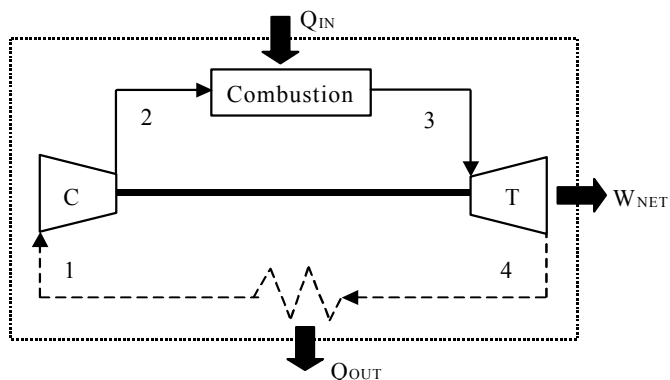

Figure 9.2 Brayton cycle.

Many chemical process systems consist of a reactor and a separation unit. These unit operations are considered to be the core of a chemical process. Energy supply to and withdrawal from the process are labelled as utilities in traditional process design (Dijkema et al., 1998). The utilities include the steam system, process furnaces, electricity generation and supply on the site, the fuel supply system for fired heaters and furnaces, process water and water treatment etc.

Production of chemicals in exothermic, elevated pressure gas-phase reactors requires compression of the reactants. The reaction heat needs to be removed, either in the reactor unit or from the hot product, or by some combination. This will depend on whether the reactor operation is *adiabatic* or *isothermal*. The reaction product is processed further to render the required product quality.

Reactors may also be operated somewhere between the isothermal and adiabatic mode. A portion of the reaction heat is then absorbed by the process gas with a subsequent temperature rise over the reactor. The remaining reaction heat is removed by a heat extraction system. This is often necessary to prevent hot spots and runaway conditions.

Many different chemical reaction systems that combine various kinds of unit operations are possible. A few examples will be described here. Figure 9.3 shows a simple diagram of a once-through adiabatic reactor system wherein cooling of the product takes place before further processing. The reaction heat is cooled away using a utility fluid. A once-through isothermal reactor system is of course also possible. Cooling will then take place by means of coils installed within the reactor shell.

In reactor systems where the conversion is limited by chemical equilibrium it is necessary to recycle the reactants. The product needs to be separated from the recycle stream within the recycle loop. A reactor-separator system with recycle is also referred to as a *chemicals synthesis loop*.

Figure 9.4 shows a system with recycle where cooling of the reactor takes place within the reactor unit, i.e. the reactor is operated isothermally. A purge stream is needed to prevent a high concentration of inert gases accumulating in the recycle loop. Build-up of inert gases may affect the reaction negatively. The purge take-off should be positioned between the separator and the reactor to prevent unnecessary loss of product. Further product processing is not shown here. Note that work is needed to separate the product from the recycle loop. Cold separation is commonly done and the work needed is then the work required for refrigeration. In addition to compressing the reactants, the recycle also needs to be

recompressed due to pressure losses in the synthesis loop. A separate compressor may be used for the recycle or in some cases the recycle is fed into a second or third stage of the existing feed compressor, as shown in the Figure 9.4.

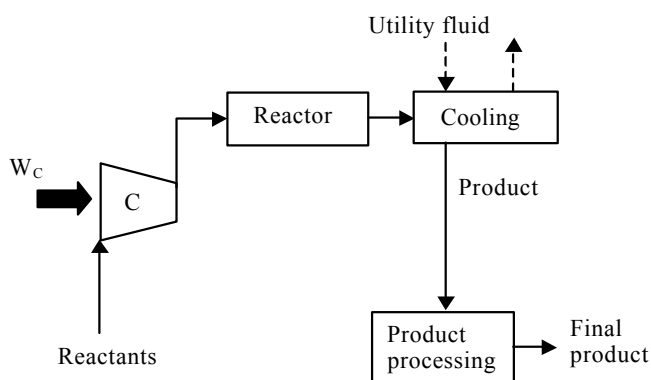

Figure 9.3 Adiabatic reactor system with high conversion and no recycle.

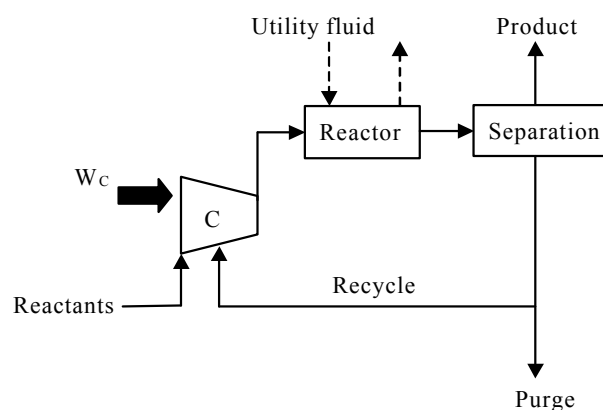

Figure 9.4 Isothermal reactor system with low conversion requiring a recycle.

An additional separation step may be included in recycle streams to remove unwanted byproduct gases that may have a negative effect on the reaction or take up unnecessary space in the loop.

In some reactor systems reactants may be in liquid form and are brought to the required reactor pressure using a pump. The pressurised liquid reactant may first be vapourised by heating it before entering the reactor or it may be injected directly into the reactor where it is vapourised by the reaction heat.

Heat integration in reaction systems are often done via heat exchange between the hot reaction product and reactant feeds.

When a turbine expander is placed downstream of the reactor in these systems, it may be required to change operating conditions or even change the flow sheet configuration to accommodate the expander. The process gas also becomes a working fluid for a power cycle.

9.4 Factors impacting on the flow sheet development

The following general impact factors on the flow sheet development have been identified and are discussed briefly:

Single pass or recycle operation

Placement of a turbine expander in a system without recycle will render an open process power cycle, with reactants flowing in and expanded product leaving the cycle. In a system with recycle, the integration would result in a semi-closed cycle with a fraction of the working fluid being recycled and reactants and product entering and leaving the cycle.

Reactor product processing

Product processing in a system with no recycle may dictate the outlet conditions of the expander placed behind the reactor. If the processing takes place at similar pressure than that of the reactor the following options can be explored to make expansion possible:

- process the product at a lower pressure if technically feasible,
- conduct the reaction at a higher pressure if feasible or
- expand the product gas after processing and exchange heat between the product gas and reactor effluent to utilise the reaction heat.

The last option will not be as attractive due to loss in heat quality with the additional heat exchange.

Recycle stream separation

The options to enable expansion, given above, are also applicable when considering separation of a product from a recycle stream.

Expansion of the reactor product creates two pressure levels within the system. Separation on the lower pressure side, after the expander, will have the advantage of decreasing the amount of gas to be recompressed. A schematic of such an integrated system is shown in Figure 9.5.

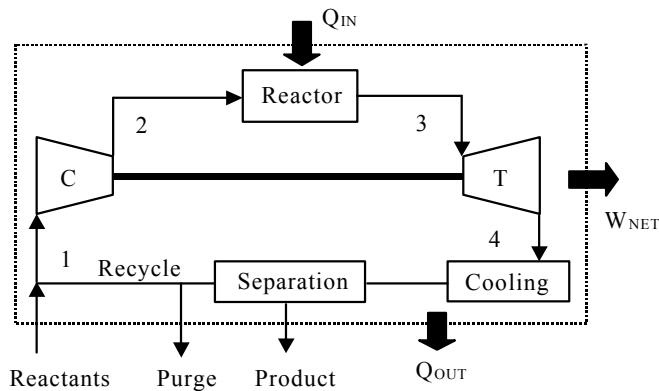

Figure 9.5 Integrated system with recycle and separation on low-pressure side.

This figure shows an adiabatic reactor and a separation operation that needs additional cooling after the gas has been expanded. Heat integration between streams 4 and 2 may be implemented to further improve the system. This will be similar to the concept of regeneration employed in conventional gas turbine cycles. The system can be visualised to be analogous to a heat engine, as shown by the heat and work flows across the dotted line boundaries in Figure 9.5. Q_{IN} represents the heat supplied to the heat engine, in this case the reaction heat. The cooling on the low pressure side of the system is a requirement for the separation as well as for the power production and is therefore a synergistic effect.

The same stream numbers used for the Brayton cycle in Figure 9.2 are used here to assist with visualisation of the power cycle within the integrated flow sheet.

If the separation can only take place at high pressure, the option of conducting the reaction at an even higher pressure to create a pressure difference can be explored. However, due to the recycle loop, it is possible to conduct separation and reaction at the same high pressure if reactants can be compressed and fed to the reactor separate from the recycle gas. Such a system is shown in Figure 9.6.

Cooling may be required for the separation, leading to removal of heat on the high pressure side of the system. Cooling is also required for the purposes of power production on the low pressure side. Heat exchange between stream 4 and a colder process stream, such as the product stream or recycle stream leaving the cold separation, can be used to improve the system further. If cold separation at subambient temperatures is required, a refrigeration work penalty must be accounted for.

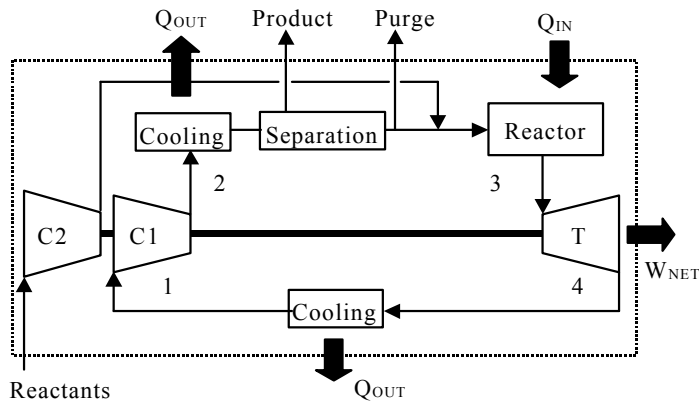

Figure 9.6 Integrated system with recycle and separation on high pressure side.

Reactor operation

The most favourable case for power production using the process gas would be an adiabatic reactor operation wherein all the reaction heat is absorbed by the process gas. This is however not always possible. In many cases the temperature of a reaction needs to be controlled to prevent reactor runaway or the temperature must be limited due to its negative effect on the reaction equilibrium.

Purge gas

Purge gas can also be expanded in a separate expander, especially if the gas is purged from the high pressure side of a system. Combustible purge gas can be utilised as fuel to drive a gas turbine.

State of reactants and reactor products

It is beneficial for compression if reactants are in the liquid form. However, in gas phase reactions most reactants are gases. If the reactant gas is at a high temperature, pre-cooling will reduce the work of the reactant compressor. Product specifications such as its state and composition may for example dictate reactor conditions that are not necessarily optimal for power production. Product specifications can, however, not be compromised.

Process gas properties

Since the process gas becomes the working fluid of a power cycle its physical properties, such as specific heat ratio and lower condensation limit, will influence the power production capacity. Changes in gas composition also makes such a process gas cycle more difficult to model compared to a steam cycle.

Volume change during chemical reaction

An increase in the number of moles (and hence volume) in the reacting mixture favours the expansion process. Expansion of larger volumes of gas would increase the work gained from the turbine expander. Many chemical reactions are however limited by chemical equilibrium. High pressure operation and an increase of volume during the reaction force the equilibrium in the opposite direction.

In all of the case studies presented here, the reactions showed a decrease in volume. However, not all considered reactions were equilibrium limited.

9.5 Case Studies

Four different chemical processes were chosen to use as case studies, namely phthalic anhydride, methanol, ammonia and ethylene oxide. The case studies are presented here to illustrate the methodology for flow sheet development and analysis.

The above-mentioned processes were chosen because they all comprise exothermic, high pressure reactions but otherwise differ significantly in terms of reactor operation, separation techniques, reactant conversion etc. The chemicals are also produced on a global scale using well known processes. This makes realistic modelling of the processes possible.

The characteristics of the chemical reactions and the reactor modelling methods are shown in Table 9.1. The information about each process is listed against the general impact factors in Table 9.2. Specific impact factors for each case are also listed. The development of the flow sheets of the integrated systems and results of flow sheet analysis for each case are briefly discussed here. The reader is referred to the specific literature about each case for more detail.

Table 9.1 Chemical reactions and reactor modelling for the various case studies.

Case	Reactions	Heat of reaction ¹	Typical reaction conditions: temperature, pressure and conversion per pass	Reactor modelling approach
Phthalic anhydride	Catalytic oxidation of naphthalene:		320-400 °C	Stoichiometric reactor using typical conversion data
	$C_{10}H_8 + 4.5O_2 \rightarrow C_8H_4O_3 + 2CO_2 + 2H_2O$	-1 793 kJ/mol $C_{10}H_8$	3.4 – 35 bar 78-88 mol% $C_{10}H_8$ to $C_8H_4O_3$	
	Formation of naphthoquinone, maleic anhydride as well as naphthalene combustion are competing reactions with much lower conversions.			
Methanol	Catalytic conversion of synthesis gas:	-90.7 kJ/mol CO	210-280 °C	Equilibrium reactor using Gibbs free energy minimisation
	$CO + 2H_2 \rightleftharpoons CH_3OH$	-49.5 kJ/mol CO_2	40-110 bar	
	$CO_2 + 3H_2 \rightleftharpoons CH_3OH + H_2O$		50 mol% CO to CH_3OH	
Ammonia	$3H_2 + N_2 \rightleftharpoons 2NH_3$	-91.9 kJ/mol N_2	370-540 °C	Equilibrium reactor using Gibbs free energy minimisation
			200-250 bar or 80-150 bar 25-35 mol% N_2 to NH_3	
Ethylene oxide	Catalytic partial oxidation of ethylene:	-107 kJ/mol C_2H_4	200-300 °C	Plug flow reactor with reaction kinetics
	$2C_2H_4 + O_2 \rightarrow 2C_2H_4O$		10-30 bar	
	Complete combustion of ethylene is a side-reaction:	-1323 kJ/mol C_2H_4	8-12 mol% C_2H_4 to C_2H_4O	
	$C_2H_4 + 3O_2 \rightarrow 2CO_2 + 2H_2O$	(both at 215 °C and 15 bar)		

1 At 25 °C and 1 bar, unless stated otherwise.

Table 9.2 Process information listed against general impact factors and specific impact factors for each case.

Item	Phthalic anhydride	Methanol	Ammonia	Ethylene Oxide
General factors				
Single pass or recycle operation	Single pass	Recycle	Recycle	Recycle
Reactor product processing	Partial condensation at a pressure lower (1.8 bar) than the reactor pressure (8-16 bar)	Crude methanol separated from the recycle is further purified by distillation	Product separated from the recycle is stored under pressure in liquid form	Crude ethylene oxide separated from recycle is further purified via desorbing and distillation
Recycle stream separation	N/A	Flash separation at pressure similar to reactor and temperature around 30 °C	Flash separation at pressure similar to reactor and subzero temperature around -23 °C	- Crude EO absorption at 7-20 bar and 15-15 °C - CO ₂ absorption at 40 bar and 250 °C
Reactor operation	Isothermal	Between isothermal and adiabatic ¹	Adiabatic	Between isothermal and adiabatic ¹
Purge gas	N/A	Typically 4 mol% of recycle	Typically 7 mol% of recycle	Typically 0.1-0.2% of recycle
State of reactants	- Air is compressed - Naphthalene is pumped and vaporised before entering the reactor	- Synthesis gas is compressed	- Synthesis gas is compressed	- Ethylene, oxygen and methane (diluent gas) are compressed
Change in volume	Decrease	Decrease	Decrease	Decrease
Specific factors				
	- Lower condensation limit of reactor product gas prevents expansion to certain pressure levels.	- Selectivities above 99% are possible and side reactions can be ignored.	- Refrigeration work penalty due to separation at subzero temperatures.	- Flammable limits – a diluent gas is used (methane) - CO ₂ formation due to a side reaction – additional separation is needed to remove CO ₂

¹ Fraction of the reaction heat is removed by reactor cooling and the remaining part is absorbed by the process gas.

Phthalic Anhydride (Perold et al., 2001)

This is the only process without recycle. A substantial pressure difference between the reactor and downstream partial condenser presents the ideal opportunity for replacing a conventional isenthalpic expansion valve with a turbine expander. Development of the integrated flow sheet is fairly simple, the expander is placed behind the reactor. Cooling of the product gas is still needed to obtain the required condensation temperature.

A process wherein reaction heat is used to drive a steam cycle was compared with one that included a turbine expander in conjunction with a steam cycle. The product gas was used to heat water and the reactor heat for superheating within the steam cycle.

During flow sheet analysis various combinations of reactor temperature and pressure were put to the test. At 400 °C and 8 bar the process with expander for example delivers a net amount of power of 8.1 MW. This is a marked improvement over the process without expander delivering only 2.7 MW under these conditions.

Methanol (Greeff et al., 2002)

The product yield in methanol synthesis is restricted by equilibrium, the synthesis loop is operated at high pressure and unconverted gas components are recycled. Such a synthesis loop consumes large amounts of compression power.

A conventional methanol process (A), wherein reaction heat is used to raise steam for a steam turbine, was compared to a process comprising a steam turbine in conjunction with a reactor product gas expander (B). Reactor pressure is 90 bar and the temperature is limited to 280°C. The gas is cooled down to 30°C for condensation of the methanol and water from the gas mixture. The conventional flow sheet is shown in Figure 9.7.

First of all, an integrated flow sheet configuration similar to the one shown in Figure 9.6 is considered, since the cold separation is done at a pressure similar to the reactor pressure. However it was found that the separation can also be done at lower pressure. The integrated flow sheet with separation on the low pressure side of the system is shown in Figure 9.8.

The turbine expander outlet is used to preheat the recycle, similar to a regenerator in a conventional Brayton cycle. The purge stream is also expanded.

The flow sheet parameter that had a significant impact during analysis of the flow sheet in Figure 9.8 is the pressure ratio across the turbine expander. Changing the pressure ratio influences the temperatures in the system, which in their turn influences the conversion in the reactor and subsequently the amount of reaction heat released.

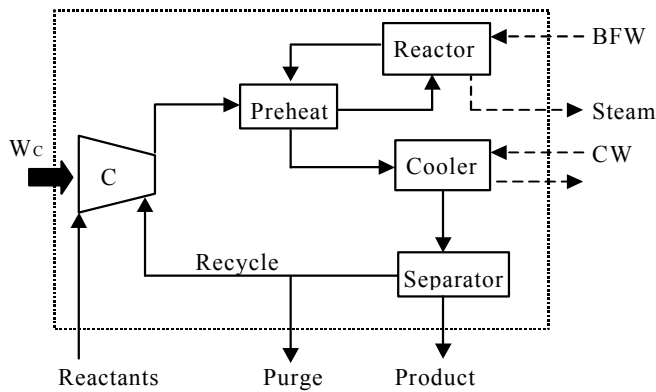

Figure 9.7 Conventional methanol synthesis flow sheet with steam raising reactor.

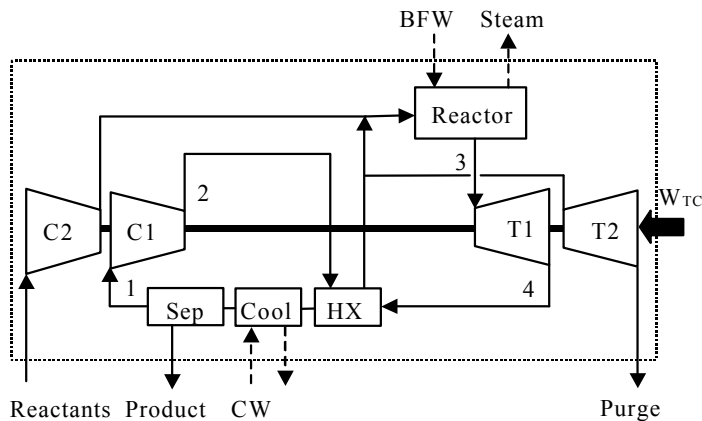

Figure 9.8 Methanol synthesis flow sheet integrated with turbine expander.

Note that the system of process gas compressors and turbines, as shown in Figure 9.8, does not deliver net power. Even after taking the steam turbine into account, it was not possible to export power from the process.

However, after adjusting the pressure ratio, the integrated system (B) consumed 24% less power than the conventional system (A). The results are shown in Table 9.3. The power consumption was expressed as kJ of work required per kg of product to take into account the variations in product flow due to changes in flow sheet parameters.

During flow sheet analysis it was also observed that it is not possible to operate the reactor adiabatically due to the temperature and corresponding conversion decreasing below acceptable levels.

Table 9.3 Methanol case study results.

Variable	A	B
x (mole% CO)	52.6	51.8
P _{EXP} (bar)	-	70
W _{NETSP} (kJ/kg CH ₃ OH)	284	215

Ammonia (Greeff et al., 2001a; Greeff et al., 2001b)

This is the only case wherein an adiabatic reactor operation can be implemented. The conventional system is similar to that shown for methanol in Figure 9.7, but with no cooling of the reactor. The hot reactor product is used to raise steam where after further cooling is required for separation. In the case study the reactor pressure is 213 bar and cold separation takes place at a similar pressure and temperature of -23°C. An additional work penalty due to refrigeration is accounted for.

Three processes were simulated and compared, namely a conventional system with a steam turbine (A) and two expander integrated systems: one with separation on the high pressure side (B), as shown in Figure 9.9, and one with separation on the low pressure side (C), shown in Figure 9.10.

During flow sheet analysis of the integrated systems the expansion pressure was varied. Similar to the methanol case it was found that this influenced the conversion. The minimum net specific work required per kg product was determined for the integrated systems and compared to that of the conventional system. The refrigeration work penalty was accounted for by using a simple heat pump calculation with an ideal coefficient of performance equal to 5.2.

Table 9.4 summarises the most important results for the three cases. The system with separation on the low pressure side (C) was found to be the most favourable with a 75% decrease in W_{NETSP} required over the conventional process without turbine expander.

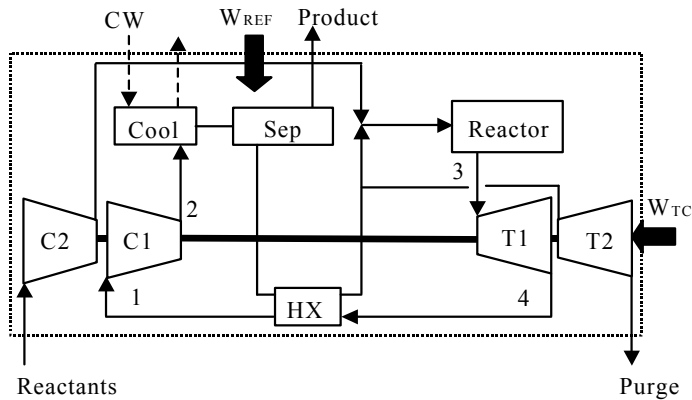

Figure 9.9 Integrated ammonia synthesis flow sheet with separation on high pressure side.

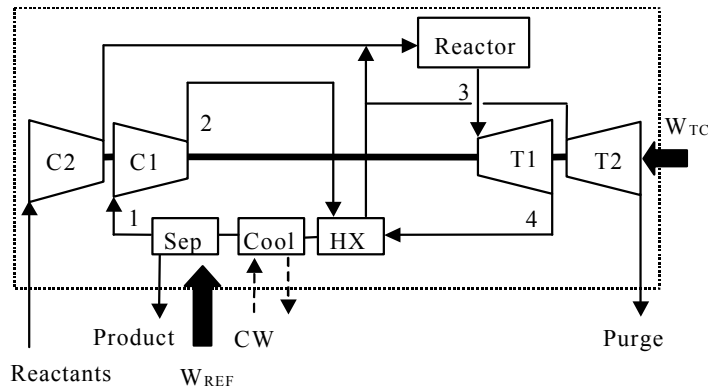

Figure 9.10 Integrated ammonia synthesis flow sheet with separation on low pressure side.

Table 9.4 Ammonia case study results.

Variable	A	B	C
x (mol% N ₂)	26	17	20
P _{EXP} (bar)	-	110	80
W _{NETSP} (kJ/kg NH ₃)	1270	706	315

Ethylene oxide

A typical ethylene oxide process is shown in Figure 9.11. This process requires two recycle separation operations, at different pressures and temperatures. Production of CO₂ is a side reaction with a much higher reaction heat compared to the ethylene oxidation reaction.

The CO₂ absorption is favoured by high pressures and is conducted at pressures higher than reactor pressure. Low conversions per pass of ethylene also make the recycle flow fairly large. The recycle compressor, C2, is therefore a major energy consumer in this process. Methane is added as a diluent gas to raise the flammable limit and reduce the peak temperature difference in the reactor.

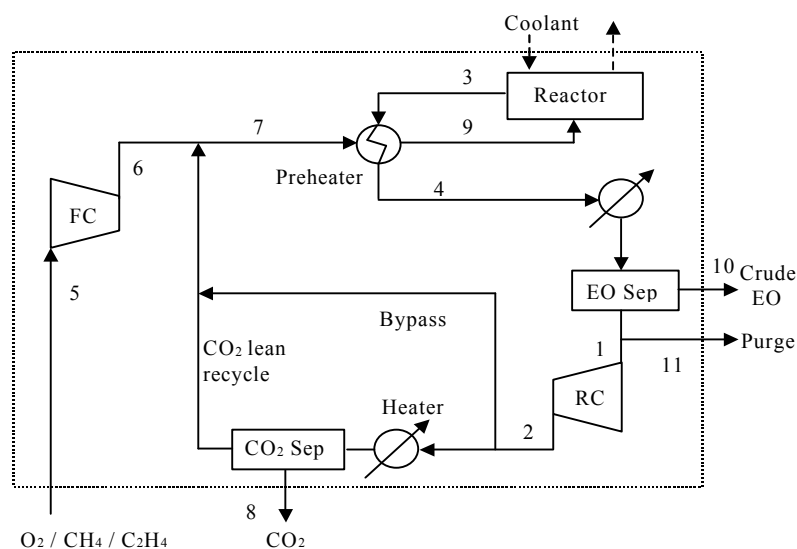

Figure 9.11 Conventional ethylene oxide production flow sheet.

The information in Table 9.2 shows that it would be possible to expand the reactor product down to the lower limit of the acceptable pressure range for ethylene oxide absorption. However, the recycle compressor would then have to compress from a much lower pressure to the required 40 bar for CO₂ separation. Then there is also the problem of mixing this 40 bar stream with the compressed reactants at 20 bar. Therefore it was decided to explore the option of increasing the reaction pressure to 40 bar in order to create a point of highest pressure and temperature within the system and a suitable pressure difference.

The flow sheet with integrated expansion turbine (B), shown in Figure 9.12, was found to be a great improvement over the conventional system (A) in Figure 9.11. The cooling step preceding separation of crude ethylene oxide satisfies the requirements of the chemical process in terms of separation and the power cycle in terms of heat removal. A synergistic effect is therefore utilised here.

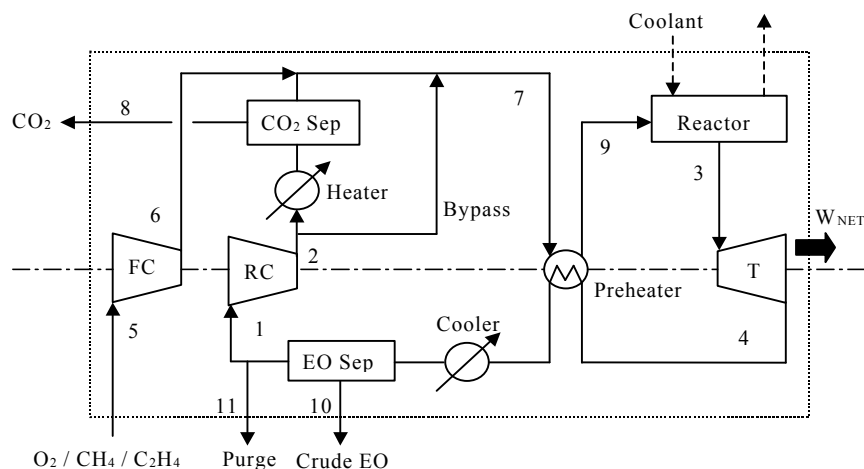

Figure 9.12 Ethylene oxide production flow sheet with integrated turbine expander.

Table 9.5 gives the most important variables for the two cases. It was possible to improve the system from one that consumes 11.8 MW of power to one that delivers 5.8 MW of power. These results are very much dependent on various process parameters in the system, such as the reaction conversion and selectivity towards ethylene oxide.

Table 9.5 Ethylene oxide case study results.

Variable	A	B
Reactor pressure (bar)	20	40
EO absorption pressure (bar)	20	20
CO ₂ absorption pressure (bar)	40	40
W _{ST} (kW)	-19 214	-19 291
W _{NET} (kW)	11 765	-5 786
W _{NETSP} (kJ/kg EO)	1 064	-502

9.6 Conclusions

A methodology was presented for the development and analysis of the flow sheets for reactor systems wherein turbine expanders are used to recover exothermic reaction heat. The basis for the flow sheet design methodology is a novel approach to combining chemical reaction and power production systems that involves the realisation of analogies, utilisation of synergistic effects and definition of appropriate system boundaries.

In the four case studies briefly discussed here, successful integration of a turbine expander was accomplished and meaningful energy savings could be obtained. The methodology was found to be a useful tool to structure the flow sheet development and analysis.

9.7 References

Bloch HP, “Consider turbo-expanders” (Editorial Comment), *Hydrocarbon Processing*, vol. 80, no. 1, p.1, 2001a.

Bloch HP, “Become familiar with turbo-expander applications” (Reliability), *Hydrocarbon Processing*, vol. 80, no.2, pp. 17-18, 2001b.

Dijkema GPJ, Luteijn CP and Weijnen MPC, “Design of trigeneration systems”, *Chemical Engineering Communications*, Vol. 168, pp. 111-125, 1998.

Dresser-Rand Products Website, “FCC Power Recovery Expanders”, <http://www.dresserrand.com/turbo/eq/expand.asp>, accessed November 2001.

Greeff IL, Ptasinski KJ and Janssen FJJG, “Integration of a turbine expander with an exothermic reactor for the combined production of power and ammonia”, *Proceedings of ECOS 2001*, vol. 1, pp. 369-375, Öztürk, A. and Gögüs, Y.A. (editors), Istanbul, Turkey 2001a.

Greeff IL, Visser JA, Ptasinski KJ and Janssen FJJG, “Integration of a turbine expander with an exothermic reactor loop – flow sheet development and application to ammonia production”, *Energy – The International Journal*, submitted for publication, 2001b.

Greeff IL, Visser JA, Ptasinski KJ and Janssen FJJG, “Utilisation of reactor heat in methanol synthesis to reduce compressor duty – application of power cycle principles and simulation tools”, *Applied Thermal Engineering*, vol. 22, pp. 1549-1558, 2002.

Moran MJ, Shapiro HN, *Fundamentals of Engineering Thermodynamics*, third ed., John Wiley & Sons Inc., New York, 1995.

Perold J, Greeff IL, Ptasinski KJ, Janssen FJJG, “Using a turbine expander to recover exothermic reaction heat – a case study on a phthalic anhydride process”, *South African Journal of Chemical Engineering*, vol. 13, pp. 1-14, 2001.

Chapter 10

Practical aspects of turbine expander integration with exothermic reaction systems

In this chapter various practical aspects of turbine expander integration with exothermic reaction systems are considered. The requirements for implementation of the idea are first discussed. Two aspects are addressed namely the implementation of a flow sheet and the implementation of turbine expander technology. Economic evaluation is considered next. A general approach to an economic analysis for a typical scenario relevant to the case studies is discussed. Thereafter the results of simple economic calculations are presented for the various case studies, within the framework of the described scenario. CO₂ emissions that are avoided for the various case studies as well as the associated environmental damage cost savings are also reported. Exergy analysis and its application in the case studies are briefly discussed. Lastly, turbine expander equipment and design considerations are looked at.

10.1 Requirements for implementation of the idea

The case studies presented in Chapters 4 to 8 are used to illustrate an idea and the positive results have proven that the idea has potential. The flow sheets developed for the various processes are by no means in enough detail to enable application. Figure 10.1 shows the steps needed before a new process or idea can be implemented. The work presented in this thesis is obviously in the research and development stage and deals with the assessment of an idea. In order to assess the idea suitable flow sheets had to be developed for different chemical processes and calculations had to be done to show that the conventional processes could be improved. However, a contribution to the technical field of expertise also had to be made. This contribution comprises the following:

- The unique approach to combining a chemical reaction system with a power cycle,
- the subsequent method to lend structure to the development and analysis of the flow sheets and
- an understanding of the behaviour of typical process gas power cycles.

Before implementation can take place for any of the process case studies, a conceptual design should be made, as shown in Figure 10.1. Deliverables of the conceptual design include a process design and specification, process flow diagrams (PFD's), plot layout, initial cost

estimate and economic evaluation. The cost estimate will typically have an accuracy of $\pm 30\%$. Rough equipment sizing needs to be done to cost the design. The basic engineering phase will deliver a piping and instrumentation diagram (P&ID), plot plan, key equipment specifications and the cost estimate will have an accuracy of $\pm 10\%$. Whether the turbine expander integration will be a retrofit or a complete redesign, the steps to enable implementation will be the same.

A very important consideration is that the technology for the unit operations that are used in the process designs is feasible and available. In this regard the turbine expander is the critical unit operation. Although turbine expander technology is available and well known, the application as illustrated by the process case studies is unique. It is possible that some research and development work on the turbine expander design is first required before a flow sheet using this turbine can be implemented. A few specific design issues will be discussed later in this chapter.

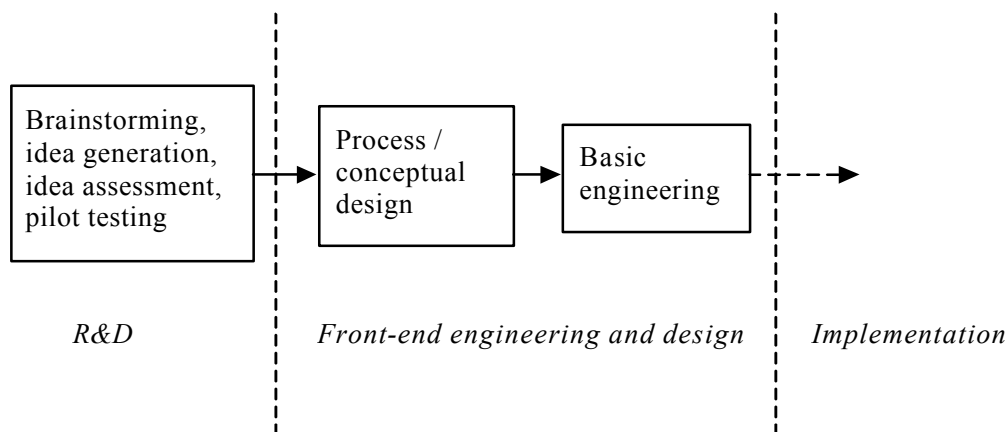

Figure 10.1 Process research, development and implementation.

10.2 Economic evaluation

Schemes with integrated turbine expanders will be evaluated similarly to general energy saving schemes. Not many energy saving schemes are implemented to save natural resources, but rather because they save money. The question to be answered is how much money will be saved and how long will it take to get a return on the investment. The types of costs associated with energy usage and the value of energy savings are:

- capital cost or initial investment,
- cost of fuels (e.g. gas, oil, coal, electricity) and
- operating costs (e.g. maintenance, labour, chemicals etc.).

Economic evaluation is performed to determine the economic potential of various alternatives to enable the selection of the alternative that is financially the most attractive. Various

profitability criteria are available that translate project cost information into a single figure to help select the best alternative. Methods in common use are the accounting rate of return (ARR) or return on investment (ROI), the payback time, net present value (NPV) and internal rate of return (IRR).

The ROI is a simple method that takes no account of the time value of money. The payback time takes little account of the timing of net savings but is useful as a first estimate. It is good for rating projects of short duration. The ROI and payback methods are however easy to apply and can be used as a rough measure to rank alternatives preparatory to using a more detailed technique. These methods are therefore useful at the concept stage of an energy saving idea or project.

The NPV and IRR are based on interest rates and are more complicated to determine. Various factors such as taxation, tax incentives, capital grants, inflation and variation in energy prices are practical considerations that should also be taken into account during project appraisal.

In all the case studies presented steam was raised in the conventional processes for cooling away reaction heat. After integration of a turbine expander the steam production was decreased and power was produced using steam in combination with a process gas cycle. In the ammonia case study steam production using the reaction heat was abandoned, all the reaction heat was transferred into the process gas power cycle.

In most of the case studies the parameter used to judge the systems was *the work required or produced per kg of chemical product*. This parameter only reflects energy consumption, which forms part of operating costs. Capital costs also have to be considered in determining the economic attractiveness of the new flow sheets. Economic analysis is, however, always case and site specific. Furthermore, at least a conceptual design comprising equipment sizes is needed to enable a proper detailed economic analysis. A general approach to an economic analysis for a typical scenario *relevant to the case studies* is discussed next. Thereafter the results of simple economic calculations are presented for the various case studies, within the framework of the scenario described here.

Figure 10.2 shows a diagram of the components of a chemical plant that is based on synthesis gas. Both methanol and ammonia are produced from synthesis gas. In these case studies the focus was on the chemical reaction system, which is only one unit of the chemical plant. Although phthalic anhydride and ethylene oxide are not produced from synthesis gas, it is assumed that these plants are part of a total site with infrastructure described here. For the purposes of this discussion the following assumptions are made regarding the chemical plant:

- the plant produces its own steam using reaction heat as well as steam boilers,
- the plant produces its own power using steam and

- fuel is imported for the steam boilers, for superheating steam and for a number of process fired heaters.

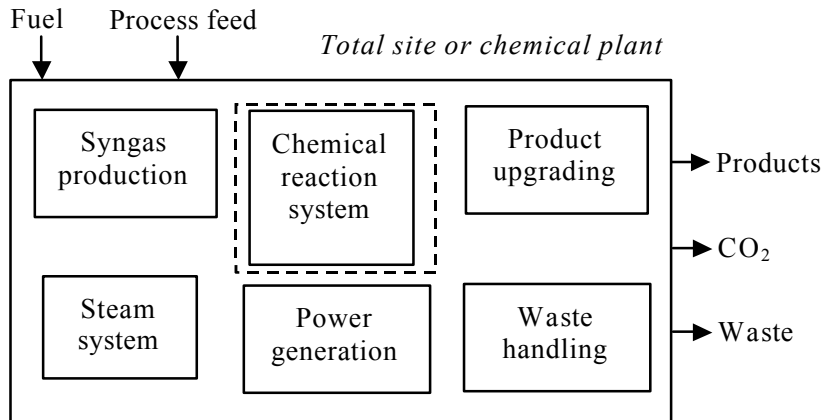

Figure 10.2 Components of a chemical plant based on synthesis gas.

The results of integrating a turbine expander into the chemical reaction system are as follows:

- excess power is available since reaction heat is utilised more efficiently by the process gas power cycle;
- the amount of steam produced by reaction heat is decreased since a portion of the reaction heat is transferred into the process gas power cycle.

The result of the economic analysis will depend on how it is decided to utilise this additional power. In this case there are the following options:

- *Option 1: Export the additional power and sell it across the fence*
The power is a product of the plant and the revenue is increased. Since steam production from reaction heat is decreased the steam handling systems will decrease in size. There will also be a decrease in power produced from steam and an associated decrease in steam turbine size. This will constitute a capital cost saving.

Simple profitability criteria are calculated as follows:

$$\text{ROI} = \text{Annual revenue from power} / \text{Capital investment}$$

or

$$\text{Payback period} = \text{Capital investment} / \text{Annual revenue from power}$$

The capital investment will include the new equipment needed for the process gas power cycle minus the savings in capital due to a decrease in the size of the steam systems.

- *Option 2: Use the additional power internally*

This means that less power needs to be generated using steam resulting in an excess of steam. Since steam is not only produced by reaction heat but also from boilers, the boiler may be turned down resulting in a fuel saving. There will be a decrease in the size of the steam systems and steam turbines as well as the boiler.

Simple profitability criteria are calculated as follows:

$$\text{ROI} = \text{Annual fuel savings} / \text{Capital investment}$$

or

$$\text{Payback period} = \text{Capital investment} / \text{Annual fuel savings}$$

A combination of the above options is also possible by selling a portion of the additional power and using the remaining power internally. The option of exporting power will probably be more attractive since power usually has a much higher value than fuel, especially in remote areas where natural gas fuel is plentiful.

Economic calculations for case studies

The results of simple economic calculations for the various case studies, within the framework of the scenario described here, are now presented.

The values for power for the different cases are shown in Table 10.1. In the ammonia and methanol cases the work required per kg of product was decreased compared to the conventional flow sheets. In the ethylene oxide case the new flow sheet delivered work per kg of product compared to the conventional process wherein work was consumed. In the synthesis gas case study the production of work was increased considerably by using a process gas power cycle instead of only a steam cycle.

Calculations were performed for the two options described previously. Note that power export is not applicable for the ammonia and methanol cases. Also note the assumptions made with regards to the power and fuel gas prices - shown in the last row of Table 10.1. Results for additional revenue for *Option 1* and annual fuel savings for *Option 2* are shown in Table 10.1.

Table 10.1 Annual savings in imported power costs or revenue for exporting power for various case studies.

Case study	Conventional process – power (kJ/kg product)	Integrated process – power (kJ/kg product)	Assumed production rate (ton/h)	Power saved (kJ/kg product)	Option 1 Additional annual revenue for exporting power (\$)	Option 2 Annual savings in imported fuel cost (\$)
Phthalic anhydride ^a	-875	-2636	11	1761	878 400	249 800
Phthalic anhydride ^b	462	-1943	11	2404	1 198 900	340 900
Methanol ^c	284	215	95	69	<i>not applicable</i>	84 100
Ammonia ^d	1269	315	50	954	<i>not applicable</i>	615 000
Ethylene oxide ^e	1064	-688	40	1752	3 176 900	903 400
Synthesis gas	-665	-915	240	250	2 716 100	772 300
Assumptions:	Power price = 20 \$/MWh		Days in operation = 340			
	Fuel gas price = 0.5 \$/million Btu					
	Efficiency of generating power internally = 30% (simple steam cycle)					

a 400 °C, 8 bar case

b 400 °C, 16 bar case

c Integrated process refers to the 70 bar expansion pressure case

d Integrated process refers to the 80 bar expansion pressure case (System C in Chapter 6)

e Integrated process refers to the case with reactor pressure at 40 bar and reactor outlet temperature at 300 °C (Case A in Chapter 7)

Retrofit versus new design

The only case studies where retrofit is a possibility is the phthalic anhydride case and the synthesis gas case. Simple payback calculations were done for these cases; the results are shown in Table 10.2. The calculations in Table 10.2 are just for illustrative purposes, the equipment costs are assumed costs. In the phthalic anhydride case study the major additional process equipment is a turbine expander and steam turbine system. In the synthesis gas case study a turbine expander and syngas compressor are additional equipment. Existing equipment such as the steam generator, cooler and separator (refer to Figure 8.4) may have to

be adjusted to operate at different pressures and temperatures. However, these costs should be low compared to those of the rotating equipment. If it is decided to export the additional power, the system will need a generator. Otherwise, other rotating machines can be connected directly to the turbine expander via a shaft. The most important conclusion drawn from the results in Table 10.2 is that, assuming similar capital investment for both options, it is more attractive to sell the power than to use it internally to save on fuel gas import.

For the other cases the flow sheets changed dramatically and new designs are needed. Capital cost will be determined by the major process units, such as the reactor, compressor, expander and separation equipment.

Table 10.2 Simple payback calculations to illustrate economic evaluation for retrofit of processes with turbine expander equipment.

Case study	Additional equipment	Estimated capital cost (installed) (Million \$)	Payback period	Payback period
			<i>Option 1</i> (years)	<i>Option 2</i> (years)
Phthalic anhydride ^a	Turbine expander	10	11.4	40.0
	Steam turbine			
Phthalic anhydride ^b	Turbine expander	10	8.3	29.3
	Steam turbine			
Synthesis gas	Turbine expander	30	11.0	38.8
	Gas compressor			

a 400 °C, 8 bar case

b 400 °C, 16 bar case

10.3 Exergy analysis

Exergy analysis is a valuable tool to evaluate and compare various process flow sheets. In process synthesis it aids in the decision making step when the best configuration must be chosen. When dealing with retrofitting of existing processes, exergy analysis is useful to identify the location and magnitude of thermodynamic inefficiencies and evaluate and compare proposed changes to increase thermodynamic efficiency.

Exergy analysis was applied in two of the case studies in this work namely, phthalic anhydride and ammonia. In both case studies there was a decrease in the total exergy loss when the new integrated flow sheets were compared to the conventional ones. In both case studies it was useful to apply the exergy analysis to the flow sheets to compare the losses over the individual unit operations. Valuable insight could be obtained into the sources of exergy losses. One should however proceed carefully when improving individual units as a reduction in the exergy loss rate of one unit can be offset by an increase in the exergy loss of another

(Tsatsaronis, 1999). For example, in the phthalic anhydride study the exergy loss of the expansion process was decreased, but it led to an increase in the exergy loss of the reactor (see section 4.4).

There are, however, also other limitations to exergy analysis that should be realized when applying the analysis. One limitation of exergy analysis is that the results will not necessarily indicate what changes should be made to a process configuration or process unit operation to effect a decrease in irreversibility (Tsatsaronis, 1999). In this regard there are some very useful guidelines, presented by Sama (1995), which will aid in detecting Second Law errors and should be used together with exergy analysis. These guidelines are referred to as the “13 common sense Second Law insights”. According to Sama (1995) the big improvements in a process design will come from eliminating Second Law errors, which will often involve changing the structure (configuration) of the process design. This was proven by the case studies in this thesis. Instead of only decreasing the temperature difference in the transfer of reaction heat to a utility fluid, a different unit operation was introduced to utilise the heat. By changing the structure of the design in this way, appreciable improvements were made in all cases.

Another concern with exergy analysis is that in optimisation of process designs it is not always practical to minimise only the exergy destruction or irreversibility. Although this will improve system efficiency, it is desired to use exergy analysis in conjunction with other objectives such as minimisation of costs or pollutant emissions (Tsatsaronis, 1999). Therefore, exergy analysis has been combined with economic analysis in *thermoeconomics* and with environmental assessments in *environomics*.

In the ammonia case study the exergy loss per kg of product was used together with the work required per kg of product as performance criteria. Although it would not make sense to minimise the absolute exergy loss, the specific exergy loss (per kg of product) was shown to have a minimum value at a certain pressure ratio across the turbine expander.

10.4 Environmental benefit

An important result of utilising reaction heat more efficiently to produce power is a reduction in the emission of carbon dioxide. The use of reaction heat to produce power in the first place may be looked upon as an alternative source of energy that does not produce carbon dioxide emissions. On improving the efficiency of utilising the reaction heat, less power needs to be obtained from other sources such as fossil fuels. Carbon dioxide emissions are therefore avoided.

The CO₂ emissions that are avoided for the various case studies are reported in Table 10.3. The calculations were based on power obtained from fossil fuels, i.e. 850 g CO₂ is avoided per

kWh of power from fossil fuels that is saved. This represents the situation in a country like South Africa where 74% of the primary energy is derived from coal (Spalding-Fecher, 2002). In the Netherlands the average CO₂ per kWh is 640 g/kWh (Janssen, 2003). This figure is an average for the whole energy industry, including coal, natural gas and nuclear fuel. The incentive to save power based on abated CO₂ emissions is therefore greater in a country like South Africa.

Various costs associated with CO₂ emissions have already been determined, e.g. costs for elimination of global warming are: Euro 0.0059/kg CO₂ (average cost) and Euro 0.035/kg CO₂ (maximum cost) (Vroonhof, 1996). Cost due to damage by CO₂ to the environment is Euro 5/ton CO₂ (Cifuentes, 1993). In this regard the annual environmental damage cost savings for the various cases are also reported in Table 10.3. These costs are reported in US\$, the exchange rate used is 1 Euro = 1.18 US\$. Note that the annual savings in fuel reported in Table 10.2 is very similar and only slightly higher compared to the savings in environmental costs for the various cases.

Table 10.3 Power saving and associated avoided CO₂ emissions calculated for various case studies.

Case study	Power saved (kJ/kg product)	CO₂ avoided (g CO₂/kg product)	Annual environmental damage cost saving (\$)
Phthalic anhydride ^a	1761	416	222 000
Phthalic anhydride ^b	2404	568	303 000
Methanol ^c	69	16	74 700
Ammonia ^d	954	225	546 600
Ethylene oxide ^e	1752	414	803 000
Synthesis gas	250	59	581 784

a 400 °C, 8 bar case

b 400 °C, 16 bar case

c Integrated process refers to the 70 bar expansion pressure case

d Integrated process refers to the 80 bar expansion pressure case (System C in Chapter 6)

e Integrated process refers to the case with reactor pressure at 40 bar and reactor outlet temperature at 300 °C (Case A in Chapter 7)

Reduction in CO₂ emissions is not only a technical matter, but also a political one. The subject of climate change due to greenhouse gases is surrounded by controversy. Up to date 106 countries have ratified the Kyoto Protocol, however, on a percentage emissions basis the number of 55% (1990 emissions) should be reached and only 37.1% have been yielded so far. In any event, emissions trading of greenhouse gases is likely to become a reality with subsequent economic consequences for businesses.

10.5 Turbine expander equipment and practical design considerations

Existing turbine expander technology

Turbine expanders have been used in air separation processes since the mid-1950's to provide low-temperature refrigeration. The number of power recovery applications is on the increase. Currently turbine expanders are mostly used in air-separation to expand down from 5 bar and in hydrocarbon processing plants to expand natural gas from as high as 200 bar (Bloch, 2001b). Expanders are also used for gas purification, e.g. H₂ or He, by condensing the contaminants (Bloch, 2001b).

A wide range of turbine expander models is available, ranging from 75 kW to 10 MW and even up to 130 MW (Bloch, 2001a; Dresser-Rand, 2001). Temperatures up to 870 °C can be accommodated (Dresser-Rand, 2001). Typical isentropic efficiencies range from 84 to 86% (Bloch, 2001b). Centrifugal (radial inflow) turbine expanders are well designed for energy recovery schemes and have also demonstrated a high degree of reliability (Bloch, 2001a).

Expander power absorption methods

Direct connection to a single stage or two stage centrifugal compressor on a single shaft is the most popular way of absorbing turbine expander power. Compression energy can almost always be used on chemical plants. Turbine expander designs exist where the bearings can also support the compressor impeller, and therefore it is only an impeller, casing and seal that are needed. In most of the case studies presented in this work the direct connection option will be suitable. Power in excess of that required by the compressor can be directed to a gear and generator. Other rotating machinery, such as pumps, can also be used to absorb the energy (Bloch, 2001c).

Turbine expander qualities

Depending on the process gas and operating conditions turbine expander designs may have different requirements. A number of design requirements are discussed next:

- *Toxic, caustic or flammable process gas*
Positive shaft seals or other special seals may be needed to seal off these gases.
- *Gas stream condensation*
In conventional impulse or axial reaction turbines discharge should take place above the dew point of the gas to prevent operation in the condensing range. The condensate can cause erosion problems. The design of radial inflow turbines has solved this problem. The rotor blades are shaped so that their walls are parallel to the vector of the forces acting on the fog droplets preventing these to drift to the walls (Bloch, 2001c). Gas streams can also be heated before entering the expander to prevent condensation on the outlet. The addition of heat will also increase the amount of power that is available.
- *Dust*
Turbine expanders that can handle condensing gas streams can usually handle suspended solid particles of two to three microns in size. Otherwise dust (and condensate droplets) needs to be removed before expansion.
- *Thrust bearing strength*
Thrust load imbalance may be caused by seal erosion, ice particles or off-design operating conditions. At inlet pressures above 10 bar thrust loads need to be balanced carefully against each other. Force measuring meters on the thrust bearings can be used. Thrust can also be controlled by a thrust control valve which manipulates the pressure behind each thrust control drum. Expander inlet pressures are above 10 bar in all the case studies (Bloch, 2001c).
- *Efficiency*
Typical efficiencies range from 84 to 86%. In all the case studies efficiencies of 80% were assumed.
- *Variable flow control*
A desired feature of a turbine expander is that it should have a high efficiency over a range of flow rates. High-quality turbine expanders have variable flow control nozzles that are capable of withstanding the total pressure and controlling the flow of the gas stream through the plant. In order to give a high efficiency over a wide range of flows, the variable nozzle should be matched to a rotor.
- *Expander inlet temperature*
Gas turbines operate at temperatures up to 1 300 °C on the expander inlet. However, blade cooling techniques are used to make this possible. Blade cooling is done by injecting air in an open-loop nozzle or by injecting steam. Available

turbine expanders for process applications can only achieve temperatures up to 870 °C. Gas turbine blade cooling techniques will have to be used to accommodate high temperature cases, such as the expansion of synthesis gas. A specific problem encountered in synthesis gas systems is metal dusting, a severe form of metal corrosion. Metal dusting depends very much on the temperature and synthesis gas composition, but typically takes place between 400 and 850 °C. Considerable work is being done to develop ceramics and other new materials for future use in high-temperature components. Cooled hot-section components in gas turbines can be replaced by ceramic parts that do not need cooling. These materials can also be utilized in turbine expanders.

10.6 References

Bloch HP, “Consider turbo-expanders” (Editorial Comment), *Hydrocarbon Processing*, vol. 80, no. 1, p.1, 2001a.

Bloch HP, “Become familiar with turbo-expander applications” (Reliability), *Hydrocarbon Processing*, vol. 80, no.2, pp. 17-18, 2001b.

Bloch HP, “Expander power absorption methods” (Reliability), *Hydrocarbon Processing*, vol. 80, no.6, 2001c.

Cifuentes LA and Have LB, Economic evaluation of air pollution abatement: benefits from health effects, *Annual review of energy and environment*, vol. 18, pp. 319-342, 1993.

Dresser-Rand Products Website, “FCC Power Recovery Expanders”, <http://www.dresserand.com/turbo/eq/expand.asp>, accessed November 2001.

Janssen FJJG, KEMA, *Personal Communication*, 2003.

Sama DA, “The Use of the Second Law of Thermodynamics in Process Design”, *Journal of Energy Resources Technology*, Transactions of the ASME, vol. 117, pp. 179-185, 1995.

Spalding-Fecher R, “Energy and Sustainable Development in South Africa”, *Sustainable Energy Watch Report*, Helio International, 2002.

Tsatsaronis G, “Strengths and limitations of exergy analysis”, in *Thermodynamic optimization of complex energy systems*, Bejan A, Mamut E (Editors), Dordrecht: Kluwer, pp. 93-100, 1999.

Vroonhof JTW, Sas HJW, Bergsma GC, “Financiele waardering van de milieu-effecten van afvalverbrandingsinstallaties in Nederland”, CEST (Delft), Milieuboek, Amsterdam, 1996.

Chapter 11

Conclusions and outlook

This work considered the integration of expansion turbines with exothermic, high-pressure gas-phase chemical reactor systems for direct conversion of the reaction heat into useful work. In such integrated systems the process gas is used as a working fluid in a power cycle while a chemical is also produced. By realising the analogy between a chemical reaction system with expansion turbine and a conventional power generation cycle, flow sheets for process gas power cycles can be created to generate power by direct expansion of reactor product gas. Reaction heat is utilised more efficiently for power production in such process gas power cycles in comparison to conventional systems wherein utility fluid power cycles are used. The concept of a process gas power cycle versus a utility fluid power cycle is best illustrated by using heat engines.

The literature review identified three types of relevant integrated systems, namely chemical plants combined with energy conversion devices, power systems incorporating chemical unit operations as well as production complexes that use synthesis gas for combined chemicals and power production. The type of system that is the subject of the thesis was considered under chemical plants combined with energy conversion devices. Not many examples of the integration of expansion turbines with chemical process streams were found in conventional literature; most of the process examples reviewed was from patent literature. During a study of the various process examples it was realised that the type of process gas stream that is used for the turbine expander is significant in determining the impact of the expander on the process operation. The various processes incorporating turbine expanders were categorized according to the type of process gas used for the expander, namely flue gas, tail gas, reactor feed or product gas.

In this work a number of case studies was conducted on the following chemical processes: production of phthalic anhydride, ammonia, methanol, ethylene oxide and synthesis gas. These processes all comprise exothermic, high-pressure reactions, but otherwise differ significantly in terms of aspects such as reactor operation, separation techniques, reactant conversion etc. A methodology was developed that lends structure to the development and analysis of the flow sheets for the mentioned systems. It was found that various factors impact on the development of flow sheets for chemical reaction systems with integrated turbine expanders. These factors include single pass or recycle operation, reaction conditions, reactor operation, conditions for separation of product and the physical properties of the process gas. The methodology takes these factors into account. In all case studies that were undertaken successful integration of a turbine expander was accomplished and exergy losses were

reduced resulting in meaningful energy savings. The methodology was therefore proved to be successful thereby reaching the objective of this research.

Simplified mathematical models were also developed for two typical process gas power cycles, namely an adiabatic reactor-separator system with equilibrium-limited reaction and one with reaction kinetics. Since the case studies revealed the importance of pressure ratio across the turbine expander, these models were used to illustrate the influence of the pressure ratio on various parameters in the process gas power cycles. In both models it was found that a high conversion in the reactor is not necessarily the best in terms of power production. The parameter that should be maximised is the work per mole flow of the recycle stream; in both cases this parameter was shown to have a clear maximum value at a certain pressure ratio. These models were useful to give an understanding of the important aspects of these kinds of systems, however, the models are far too simple to use in the design of real systems.

An important result of utilising reaction heat more efficiently to produce power is a reduction in the emission of carbon dioxide. Even though there is controversy around the subject of greenhouse gases being linked to climate change, emissions trading of these gases is likely to become a reality. This will influence future process designs and economic evaluations of projects.

Exergy analysis was also applied in this work, namely in the phthalic anhydride and ammonia case studies. In both cases there was a decrease in the total exergy loss when the new integrated flow sheets were compared to the conventional ones. It was useful to apply the exergy analysis to the flow sheets to compare the losses over the individual unit operations. Valuable insight was obtained into the sources of exergy losses.

Before any of the above-mentioned improved flow sheets can be implemented, a conceptual design is needed. Deliverables of such a conceptual design include a process design and specification, process flow diagrams, plot layout, initial cost estimate and economic evaluation. Rough equipment sizing is also needed to cost the design to enable economic analysis. The result of the economic analysis will depend on how it is decided to utilise the additional power that may be available on utilising the reaction heat more efficiently.

Literature indicates that turbine expander technology is well developed and can be customised to meet the requirements of different operating scenarios. Temperatures up to 870 °C can be accommodated, and equipment sizes range from 75 kW to 10 MW and even up to 130 MW. Designs are available that can handle condensing gas streams and streams containing suspended solid particles. Efficiencies are also good and the machines have demonstrated a high degree of reliability. In the case of very high temperature environments, as in the expansion of hot synthesis gas, gas turbine blade cooling techniques will have to be used. Ceramic materials are also an option for such conditions. The use of turbine expander

technology under the conditions described in the various case studies of this thesis is therefore not considered to be a particular problem.

Outlook

Since the results of the all the case studies in this work were positive it is concluded that the idea of direct reaction heat recovery for power production has potential. It is hoped that the methods, guidelines and examples presented in this work will be useful for future conceptual designs of processes integrated with turbine expanders. It is further hoped that such designs will eventually be implemented in practice. Obviously this will depend on the result of proper economic evaluations. In this regard there is a need to develop the conceptual flow sheets for the processes presented here further to a level of detail that will enable such evaluations.

The concept of a process gas power cycle that uses a process gas as a working fluid should be developed further to promote the combination of chemical processes and power cycles on this integrated level. A structured approach to the design of chemical engineering systems is valuable and also improves the outcome.

Publications

Greeff IL, "Influence of Fluorination on the Pressure Drop Characteristics in HDPE Pipes", *South African Journal of Chemical Engineering*, vol. 11, no. 1, pp. 38-47, 1999.

Greeff IL, "Piping and the energy balance", *Chemical Processing*, vol. 62, no. 9, 1999.

Perold J, Greeff IL, Ptasiński KJ, Janssen FJJG, "Using a turbine expander to recover exothermic reaction heat – a case study on a phthalic anhydride process", *South African Journal of Chemical Engineering*, vol. 13, no. 2, pp. 1-14, 2001.

Greeff IL, Ptasiński KJ and Janssen FJJG, "Integration of a turbine expander with an exothermic reactor for the combined production of power and ammonia", *Proceedings of ECOS 2001*, vol. 1, pp. 369-375, Öztürk, A. and Gögüs, Y.A. (editors), Istanbul, Turkey 2001.

Van Schijndel PPAJ and Greeff IL, "Energy analysis and environmental impact assessment of a cement plant", *Journal of Energy in Southern Africa*, vol. 13, no.1, pp. 14-21, 2002.

Greeff IL, Visser JA, Ptasiński KJ and Janssen FJJG, "Utilisation of reactor heat in methanol synthesis to reduce compressor duty – application of power cycle principles and simulation tools", *Applied Thermal Engineering*, vol. 22, pp. 549-558, 2002.

Greeff IL, Visser JA, Ptasiński KJ and Janssen FJJG, "Integration of a turbine expander with an exothermic reactor loop – flow sheet development and application to ammonia production", *Energy – The International Journal*, vol. 28, no. 14, pp. 1495-1509, 2003.

Greeff IL, Visser JA, Ptasiński KJ and Janssen FJJG, "Using turbine expanders to recover exothermic reaction heat – flow sheet development for typical chemical processes", *Energy – The International Journal*, accepted for publication, 2003.

Greeff IL, Visser JA, Ptasiński KJ and Janssen FJJG, "Mathematical modelling of a process gas power cycle for the direct recovery of exothermic reaction heat", *SAIChE Congress*, 3-5 September 2003, Sun City, South Africa.

Curriculum vitae

Isabella Greeff spent her school years in Pretoria, South Africa, and also obtained her bachelors degree in chemical engineering at the University of Pretoria in 1993. She worked for Rand Water in 1994 whereafter she joined the Council for Scientific and Industrial Research (CSIR) in 1995. Here she worked in the field of environmental engineering. She completed her honours degree in water utilisation engineering during this time. In 1997 she joined the staff of the Department of Chemical Engineering, University of Pretoria. She completed her masters degree in this department. She then proceeded to do her doctorate through the University of Eindhoven on a part-time basis while stationed in South Africa. In 2000 she joined Fluor to obtain detailed process design experience. Currently she is employed by Sasol Technology in Johannesburg where she is part of a team that focuses on the company's gas-to-liquids technology.

She is married to Pierre and has a son, Jacobus.