

Wind data analysis in the center of Eindhoven

Citation for published version (APA):

Wit, de, M. H., Wisse, J. A., & Stathopoulos, T. (2001). Wind data analysis in the center of Eindhoven. In J. Wisse, K. Kleinman, C. Geurts, & M. de Wit (Eds.), *Third European & African Conference on Wind engineering, July 2-6, 2001, Eindhoven. The Netherlands* (pp. 293-300). Technische Universiteit Eindhoven.

Document status and date:

Published: 01/01/2001

Document Version:

Publisher's PDF, also known as Version of Record (includes final page, issue and volume numbers)

Please check the document version of this publication:

- A submitted manuscript is the version of the article upon submission and before peer-review. There can be important differences between the submitted version and the official published version of record. People interested in the research are advised to contact the author for the final version of the publication, or visit the DOI to the publisher's website.
- The final author version and the galley proof are versions of the publication after peer review.
- The final published version features the final layout of the paper including the volume, issue and page numbers.

[Link to publication](#)

General rights

Copyright and moral rights for the publications made accessible in the public portal are retained by the authors and/or other copyright owners and it is a condition of accessing publications that users recognise and abide by the legal requirements associated with these rights.

- Users may download and print one copy of any publication from the public portal for the purpose of private study or research.
- You may not further distribute the material or use it for any profit-making activity or commercial gain
- You may freely distribute the URL identifying the publication in the public portal.

If the publication is distributed under the terms of Article 25fa of the Dutch Copyright Act, indicated by the "Taverne" license above, please follow below link for the End User Agreement:

www.tue.nl/taverne

Take down policy

If you believe that this document breaches copyright please contact us at:

openaccess@tue.nl

providing details and we will investigate your claim.

Wind data analysis in the center of Eindhoven

Martin H. de Wit, PhD¹

Jacob A. Wisse, Prof.¹

Ted Stathopoulos, Prof.²

ABSTRACT

On the basis of measured field data, the paper evaluates the procedure to predict the wind velocity in the urban boundary layer in a town using available airport data. In particular, the accuracy of the prediction of velocity and wind direction and their statistical deviations are dealt with in the present study.

1. INTRODUCTION

In the center of Eindhoven (the Netherlands) on the campus of the University of Technology (TU/e), measurements of the horizontal and vertical components of wind velocity as well as the wind direction at a height of 44.6 m have been performed since January 1996 (Geurts 1997, v. Mook 1998). This site provides an excellent opportunity to investigate the accuracy of models that predict wind velocities in the urban boundary layer of the town from wind data measured at the airport outside the town.

2. SITE DESCRIPTION AND MEASUREMENTS

The city of Eindhoven has about 200,000 inhabitants. The co-ordinates are 51.26 N and 5.30 E. The nearest hills and the North Sea are at least 80 km away. Prevailing wind directions for strong winds are west and southwest.

The Eindhoven Airport is located 7.5 km west from the test site (see Fig.1). The town border is about 4 km from the mast in the west direction, 8 km in the southwest direction and 6 km in the northwest (see Fig.1, left). Outside the town there are some forests and agricultural land. In the westerly directions there are mainly low-rise buildings of about 10 m high and can be classified as 'densely built-up suburbs, towns' with a roughness length of about 1m (Wieringa 1992). In the southwest direction at least 500 m from the test site there are some buildings of about 45 meters high (in Fig.1, right: Rabobank).

¹Eindhoven University of Technology, P.O. Box 513, 5600 MB Eindhoven, The Netherlands

²Concordia University, Montreal, Quebec, Canada H3G 1M8

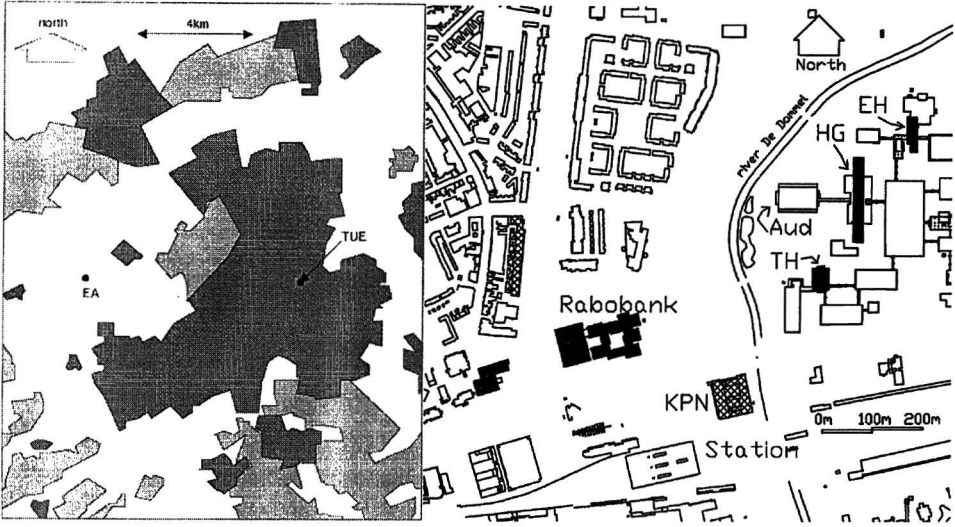

Figure 1 Left: The location of the test site (TUE) and the Eindhoven Airport (EA). The grey area is forest
 Right: The test site; the mast is placed on 'Aud'

A mast with an anemometer and directional vane is placed on the flat roof of a 14m high building (Fig.1 right: Aud, Fig.2). In the vicinity of the mast there are no buildings higher than 15m in the westerly direction. At 127m east of the mast there is the long main building of TU/e, which is 44m high (in Figs. 1, 2: HG) and a smaller building, 45m high, is located on the south (in Fig.1: TH). This building will not have an impact at the anemometer for southerly winds.

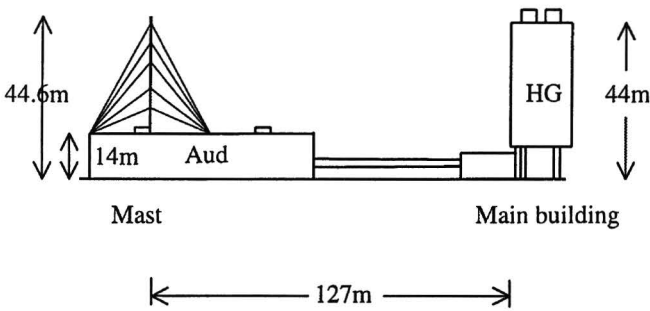

Figure 2 View from the south

At the airport the velocity is measured with a 3-cup anemometer and the direction with a vane at the standard height of 10m. The hourly direction is the average of the last 10 minutes of every hour. The hourly wind velocity provided

by the Royal Netherlands Meteorological Institute (KNMI) is the hourly average of the so-called potential wind velocity i.e. a velocity, on which an exposure correction factor is applied (Verkaik 2000). With this correction the potential wind velocity corresponds to the hypothetical wind that would have blown there from all directions at 10m over unobstructed terrain with a roughness length 0.03m. (Wieringa 1994). The measured velocities at the airport were rounded to +/- 0.5 m/s. The correction is applied on these rounded values, so the decimal digits of a corrected velocity do not imply the suggested accuracy. The accuracy is 0.5 m/s for $U_{\text{airport}} < 5$ m/s and 10% for $U_{\text{airport}} > 5$ m/s (Verkaik 2000). The accuracy of the wind direction is +/- 5°. At the test site in the city the velocity vector is measured with a ultrasonic anemometer (Gill Solent research anemometer) (accuracy 1.5% rms). The horizontal velocity and the direction are calculated from the three components.

In this study, wind data for a two-year period (1-12-1997 to 1-12-1999) is used. The hourly wind direction is 64% of the time between 185° and 355° (counting clockwise from north). If only these hours of westerly winds are selected the correlation coefficient between the hourly mean wind velocity at the airport and in the city will be 0.95.

3. THEORY

We calculate the wind amplification factor γ ($\gamma = U_{\text{city}}/U_{\text{airport}}$) as an engineer might do, i.e. without any knowledge about measured velocities in the city. For this we use two models:

- the power law
- the logarithmic law with the similarity model

Power law (Davenport 1965)

The wind amplification factor γ of the horizontal velocity at height z_c above a terrain with roughness length z_{oc} and the velocity at height z_a above a terrain with roughness length z_{oa} is given by:

$$\gamma = \left(\frac{z_c}{\delta(z_{oc})} \right)^{\alpha(z_{oc})} \left(\frac{\delta(z_{oa})}{z_a} \right)^{\alpha(z_{oa})} \tag{1}$$

The values given in Davenport (1965) of α and δ are:

open terrain: $\alpha=0.16$ and $\delta=275\text{m}$; suburban terrain: $\alpha=0.28$ and $\delta=400\text{m}$

For the potential velocity at the airport: $z_{oa}=0.03\text{m}$ and $z_a=10\text{m}$

An estimation for the roughness length according to the revised Davenport classification (Wieringa 1992) is 1m. Geurts (1997) estimated the roughness length at the TU/e site from the turbulence intensity ($I=1/\ln((z-d)/z_0)$; d is the displacement length). His results are plotted in Fig.3.

At the height $z_c=44.6\text{m}$ of the anemometer at the TU/e the velocity ratio is then according to the power law: $\gamma=0.92$.

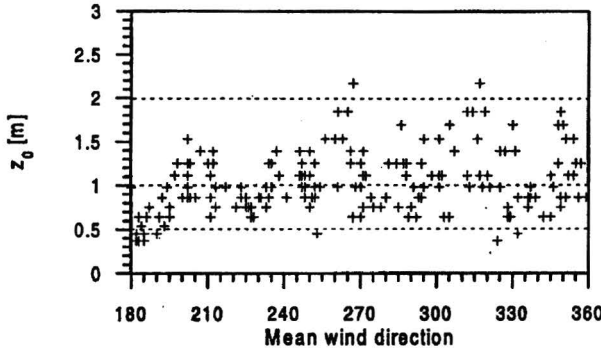

Figure 3 Roughness length in full scale determined from turbulence intensity (Geurts 1997)

Logarithmic law with similarity model

The velocity at the height of the urban boundary layer h_{ibl} is assumed to be equal to the velocity at the same height above the airport. The height of the urban boundary layer is determined with the formula of Wood (1982) with $x=4000\text{m}$ (the distance to the town border):

$$h_{ibl} = 0.28z_{oc} (x/z_{oc})^{0.8} = 213\text{m} \quad (2)$$

Up to $0.2h_{ibl}$ and for $z > 20z_o+d$ the velocity in the city is determined with the similarity formula (Bietry et al 1978).

From the height of buildings in westerly direction the displacement length d is estimated as $7 < d < 10\text{m}$. We shall use the value that Geurts (1997) estimated: $d=10\text{m}$. So: $20z_o+d=30\text{m} < z_c$ (the height of the mast in the city).

Between $z=h_{ibl}$ and $z=0.2h_{ibl}$ the velocity is estimated with a linear interpolation. (Högström et al 1982).

As $z_c > 0.2h_{ibl}$ and $z_c < h_{ibl}$:

$$\gamma = \left(\frac{u_{*c} \ln((0.2h_{ibl} - d)/z_{oc})}{u_{*a} \ln(z_a/z_{oa})} \right) * \frac{h_{ibl} - z_c}{0.8h_{ibl}} + \left(\frac{\ln(h_{ibl}/z_{oa})}{\ln(z_a/z_{oa})} \right) * \frac{z_c - 0.2h_{ibl}}{0.8h_{ibl}} \quad (3)$$

In Simiu and Scanlan (1996) a formula is given that relates the ratio z_{oc}/z_{oa} to the friction velocity ratio u_{*c}/u_{*a} . Bietry et al (1978) found from measurements: $u_{*c}/u_{*a}=1.46$ for a change in roughness length from $z_{oa}=0.07\text{m}$ to $z_{oc}=2.5\text{m}$. As the ratio $z_{oc}/z_{oa}=1/0.03 \approx 2.5/0.07$, we assume $u_{*c}/u_{*a} 1.46$ and find: $\gamma=0.88$.

With different assumptions for roughness length at the airport, displacement length in the city, etc. more different values can be found. For instance, if we assume $d=7.5$ instead of 10m for the displacement length Equation 3 will yield $\gamma=0.90$.

The real roughness change is different since we used the potential wind at the airport with the corresponding roughness length of 0.03m instead of the real velocity with the real roughness length (about 0.25m). In order to carry out a sensitivity analysis, we calculate the velocity at 10m height over a terrain with $z_o=0.25$ m instead of 0.03m from the potential wind using the logarithmic law and estimate the amplification factor for this velocity and a roughness change of $z_{oa}=0.25$ to $z_{oc}=1$ m. For this transformation a 'blending height' (Wieringa 1994) of 60m is used. The change of roughness from $z_{oa}=0.25$ to $z_{oc}=1$ m is about the same as from 0.07m to 0.3m, for which Bietry et al (1978) found: $u_{*c}/u_{*a}=1.15$. The amplification factor turns out to be quite sensitive as we now find $\gamma=1.10$ instead of $\gamma=0.88$.

4. ANALYSIS OF MEASUREMENT RESULTS

In the left diagram of Fig.4 a data selection for westerly direction ($270^\circ \pm 15^\circ$) is plotted with the regression line, the slope of which, i.e. the wind amplification factor γ , is equal to 0.84.

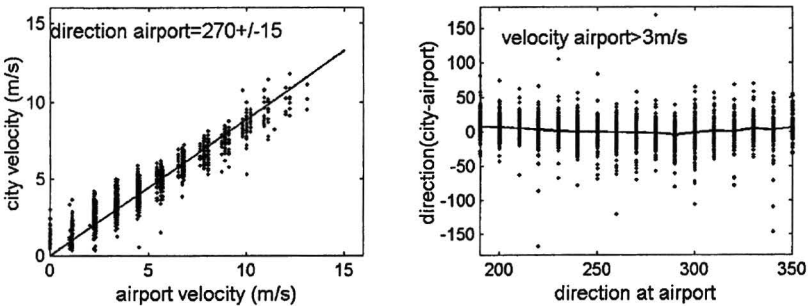

Figure 4 Comparison of local and airport velocity and direction for westerly winds

One can see that the difference $U_{city}-\gamma U_{airport}$ is more or less independent of the wind velocity. We will assume a normal distribution. So within a confidence interval of 68%: $\langle U_{city} \rangle = \gamma U_{airport} \pm \sigma$. More data would be necessary to be more conclusive about the distribution around this line.

The range of velocities used to determine the amplification factor could have an influence on the result. In Table 1 the amplification factors are given for $U_{airport}>1$ m/s, $U_{airport}>3$ m/s and $U_{airport}>5$ m/s and for different wind directions.

Table 1. The amplification factor for different wind directions and for $U_a > U_{\text{threshold}}$

$U_{\text{threshold}}$ (m/s)	Direction $210^\circ \pm 15^\circ$	Direction $240^\circ \pm 15^\circ$	Direction $270^\circ \pm 15^\circ$	Direction $300^\circ \pm 15^\circ$	Direction $330^\circ \pm 15^\circ$	Direction $195^\circ - 345^\circ$
1	0.87	0.86	0.89	0.85	0.82	0.87
3	0.86	0.86	0.88	0.85	0.80	0.86
5	0.84	0.84	0.86	0.82	0.77	0.84

As the number of data is quite high the value of γ in Table 1 is accurate to the second digit. The influence of the threshold can be about 3%. Systematic errors of the anemometers however, are not yet accounted for. A rough estimation of the real accuracy is $\pm 10\%$.

In Table 2 the standard deviation for the difference $U_{\text{city}} - \gamma U_{\text{airport}}$ and the number of data points are shown. Without the rounding of the data (± 0.5 m/s) of the airport this standard deviation could have been somewhat less. The difference between the standard deviation for a threshold of 1m/s and 5m/s turns out to be less than expected. If all data between 195° and 345° is grouped together, the standard deviation becomes 0.7.

It is clear that the prevailing winds are from the south-southwest. This is especially true of the strong winds.

Table 2. The standard deviation of $U_{\text{city}} - \gamma U_{\text{airport}}$ for the different threshold velocities based on the assumption that the difference is normally distributed. In brackets is the number of data.

$U_{\text{threshold}}$ (m/s)	Direction $210^\circ \pm 15^\circ$	Direction $240^\circ \pm 15^\circ$	Direction $270^\circ \pm 15^\circ$	Direction $300^\circ \pm 15^\circ$	Direction $330^\circ \pm 15^\circ$	Direction $195^\circ - 345^\circ$
1	0.7 (3575)	0.7 (2610)	0.7 (1672)	0.7 (871)	0.8 (756)	0.7
3	0.7 (3160)	0.6 (2230)	0.7 (1325)	0.7 (641)	0.6 (506)	0.7
5	0.6 (2018)	0.6 (1392)	0.6 (643)	0.7 (288)	0.5 (213)	0.6

Another way of estimating γ is by calculating the mean value and the standard deviation of the hourly ratio $U_{\text{city}}/U_{\text{airport}}$. So $\langle U_{\text{city}}/U_{\text{airport}} \rangle = \gamma \pm \sigma$. Figure 4 shows that γ and σ are very velocity dependent and for low velocities the regression analysis breaks down. For $U_{\text{airport}} > 5\text{m/s}$ and the same directions as in Table 1 we find slightly higher γ values: 0.85, 0.85, 0.87, 0.83, 0.78, 0.85 with standard deviations σ equal to 0.08, 0.08, 0.09, 0.10, 0.08, 0.08.

The direction of the local wind differs on average slightly from the direction at the airport (see Fig.5 left) and there is a more or less random variation around that value (see Fig.4 right). Both mean and rms values are strongly velocity dependent, see Table 3

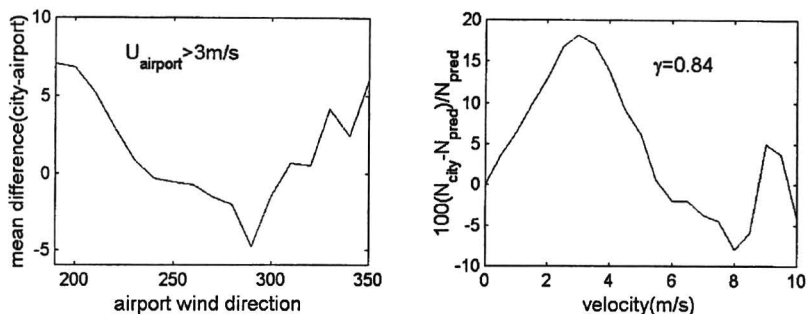

Figure 5 Left: Mean difference between the wind direction in the city and at the airport
 Right: The change in the frequency distribution of the velocity U_{city} if the measured data are exchanged for a predicted value

The right diagram of Fig.5 shows the percentage difference of the number N_{city} of hours the measured velocity in the city exceeds a certain value (the velocity on the x-axis) and the number N_{pred} one would find with a predicted value for this velocity ($U_{pred}=0.84U_{airport}$), for all directions between 195° and 345° at the airport. For velocities exceeding 5m/s the error is about 7% at maximum but below 5m/s a different amplification factor is needed; for instance, for velocities higher than 3m/s the error found is about 18%.

Table 3. The standard deviation (degrees) of the difference between wind direction at the airport and in the city based on the assumption that the difference is normally distributed

$U_{threshold}$ (m/s)	Direction $210^\circ \pm 15^\circ$	Direction $240^\circ \pm 15^\circ$	Direction $270^\circ \pm 15^\circ$	Direction $300^\circ \pm 15^\circ$	Direction $330^\circ \pm 15^\circ$
1	14	17	22	27	26
3	9	11	14	17	18
5	7	8	12	15	17

5. DISCUSSION

The following points can be made:

- The wind amplification factor based on the measured data has been determined to be between 0.8 and 0.9. However, depending on the chosen model and assumptions, values ranging from 0.85 to 1.1 can easily be established. In fact, the ratio of hourly velocity averages U_{city} and $U_{airport}$ changes each hour due to the randomly distributed velocity with a standard

- deviation of about 0.7 m/s that has to be added to the predicted wind velocity.
- In the city there are 7% more hours with $U > 5$ m/s than predicted by the multiplication of the airport data with a constant average amplification factor.
 - The frequency function for the velocity found by multiplying the airport data with a constant factor is different from that measured in the city. The difference between wind directions is less than 6° on average but has a significant random variation. This can only partially be explained from the inaccuracy of the measurement devices.

In conclusion, the data obtained in the measurements reported in this paper offer significant insight in the possible accuracy of wind velocity predictions in the city. Without a measured wind profile in the urban boundary layer the results presented here are not sufficient to suggest which prediction model is the most representative of the real situation. It would be of interest to compare these data with relevant wind tunnel measurements.

REFERENCES

- Biétry, J., C. Sacré, E. Simiu. 1978. Mean wind profiles and change of terrain roughness. *J. of Structural Division, ASCE*, pp. 1585-1593
- Davenport, A.G. 1965. The relationship of wind structure to wind loading. In: Proceedings of the Symposium on Wind Effects on Buildings and Structures Vol. 1 National Physical Laboratory. Teddington, U.K., Her Majesty's Stationery Office pp. 53-102
- Geurts, C.P.W. 1997. *Wind induced pressure fluctuations on building facades*. PhD thesis, Eindhoven University of Technology.
- Högström, U., H. Bergström and H. Alexandersson. 1982. Turbulence characteristics in a near neutrally stratified urban atmosphere. *Boundary Layer Meteorology*, 23, pp. 449-472
- Mook, F.J.R. van. 1998. *Description of the measurements set-up for wind and driving rain at the TUE*. Fago – report 98.04.K.
- Simiu, E. and R.H. Scanlan. 1996. *Wind effects on structures*; third edition, Wiley International
- Verkaik, J. W. 2000. Evaluation of two gustiness models for exposure correction calculations. *Journal of Applied Meteorology*, 39, pp.1613-1626
- Wieringa, J. 1992. Updating the Davenport roughness classification. *J. Wind Eng. Ind. Aerod.*, 41, pp. 357-368
- Wieringa, J. 1994. Does representative wind information exist? East European Conf. on Wind Engineering, Warsaw, Poland.
- Wood, D.H. 1982. Internal boundary-layer growth following a step change in surface roughness. *Boundary Layer Meteorology*, 22, pp. 241-244