

Practical symbolic model checking of the full μ -calculus using compositional abstractions

Citation for published version (APA):

Kelb, P., Dams, D. R., & Gerth, R. T. (1995). *Practical symbolic model checking of the full μ -calculus using compositional abstractions*. (Computing science reports; Vol. 9531). Technische Universiteit Eindhoven.

Document status and date:

Published: 01/01/1995

Document Version:

Publisher's PDF, also known as Version of Record (includes final page, issue and volume numbers)

Please check the document version of this publication:

- A submitted manuscript is the version of the article upon submission and before peer-review. There can be important differences between the submitted version and the official published version of record. People interested in the research are advised to contact the author for the final version of the publication, or visit the DOI to the publisher's website.
- The final author version and the galley proof are versions of the publication after peer review.
- The final published version features the final layout of the paper including the volume, issue and page numbers.

[Link to publication](#)

General rights

Copyright and moral rights for the publications made accessible in the public portal are retained by the authors and/or other copyright owners and it is a condition of accessing publications that users recognise and abide by the legal requirements associated with these rights.

- Users may download and print one copy of any publication from the public portal for the purpose of private study or research.
- You may not further distribute the material or use it for any profit-making activity or commercial gain
- You may freely distribute the URL identifying the publication in the public portal.

If the publication is distributed under the terms of Article 25fa of the Dutch Copyright Act, indicated by the "Taverne" license above, please follow below link for the End User Agreement:

www.tue.nl/taverne

Take down policy

If you believe that this document breaches copyright please contact us at:

openaccess@tue.nl

providing details and we will investigate your claim.

Eindhoven University of Technology
Department of Mathematics and Computing Science

Practical Symbolic Model Checking of the full μ -calculus
using Compositional Abstractions

by

Peter Kelb, Dennis Dams and Rob Gerth

95/31

ISSN 0926-4515

All rights reserved

editors: prof.dr. J.C.M. Baeten

prof.dr. M. Rem

Computing Science Report 95/31
Eindhoven, October 1995

Practical Symbolic Model Checking of the full μ -calculus using Compositional Abstractions

Peter Kelb
OFFIS*

Dennis Dams
Utrecht University[†]

Rob Gerth[‡]
Eindhoven University of Technology[§]

Abstract

We apply abstract interpretation techniques to reduce the time and space requirements for model checking the full μ -calculus over parallel processes. The abstractions can be computed compositionally. The techniques have been implemented in a StateCharts model checker. Experiments show a 17-fold reduction on the average in the size of the BDDs on non-trivial specifications.

1 Introduction

Abstraction techniques [CGL94, LGS⁺95, DGG94, CR94] offer one answer to the so-called state explosion problem that is inherent to verification by model checking. Such techniques allow aspects of a program that are irrelevant to the property being checked to be ignored, thus reducing the model representing the program's (relevant) behaviors.

In symbolic model checking [BCM⁺92], both the state space of a program and its transition relation are encoded as boolean functions which are compactly represented by Binary Decision Diagrams (BDD's) [Bry92]. In this setting, abstractions should aim at the reduction of BDD's. It turns out that the blow-up of a BDD representing the behavior of a concurrent program usually results from the interdependency between individual processes rather than from the large total number of global states.

In this paper, we present an abstraction method which abstracts from such interdependencies in designated parts of processes as indicated by a user. We provide both universal and existential abstractions, suitable for verifying universal and existential properties expressed in the full μ -calculus [Koz83]. Combination of both types allows for verification of arbitrary μ -calculus properties.

The method is fully compositional: the abstraction of a concurrent program is computed from user-specified abstractions of its individual components. Hence, only the BDD's for the transition relations of the (abstracted) components have to be pre-computed.

*Westerstraße 10–12, 26121 Oldenburg, Germany. Peter.Kelb@arbi.informatik.uni-oldenburg.de

[†]Dept. of Philosophy, Heidelberglaan 8, 3584 CS Utrecht, The Netherlands. Dennis.Dams@phil.ruu.nl.

[‡]Currently working in ESPRIT project P6021: "Building Correct Reactive Systems (REACT)".

[§]Dept. of Mathematics and Computing Science, P.O. Box 513, 5600 MB Eindhoven, The Netherlands. robg@win.tue.nl

The duality that exists in theory between the two types of abstraction is in practice often disturbed. The reason is that existential abstractions tend to restrict the behavior of a program to the extent that relatively few existential properties may be verified.

We investigate a solution to this problem by providing conditions under which the universal abstraction may be used for verifying existential properties as well. This results in an optimized definition of the existential abstraction, obtained by combining the original existential abstraction together with the restricted universal abstraction.

This method has been integrated in a symbolic model checker for the language of State-Charts [Har87]. Experimental results display a 17-fold reduction in space on the average for the verification of many non-trivial properties, including universal and existential properties, as well as properties that have both universal and existential aspects. As the time complexity of BDD operations is related to the size of the BDDs they operate on, the time of a symbolic model check substantially decreases as well. Our optimized existential abstractions are essential for obtaining these results. Indeed, without them no useful existential abstractions could be defined.

2 Abstract Interpretation

Many of the results and constructions below are most easily expressed using the language of *Abstract Interpretation* [CC77]; a general framework to define static analyses of programs. The basic tenet is that the operations of a programming language which operate on concrete values can be mimicked by corresponding abstract operations defined over abstract values that describe sets of concrete values.

The starting point is choosing a set of *abstract states*, ${}^\alpha\mathcal{V}$. An abstract state *describes* sets of concrete states. The intention is that the interpretation of μ -calculus formulae is adapted over abstractions of transition systems; such an abstract interpretation of a formula φ then yields an abstract state ${}^\alpha v$. This result should be *safe* in the sense that in every set of concrete states that is described by ${}^\alpha v$, φ holds — i.e., every such described set should be a subset of the concrete (standard) interpretation of φ . Hence, if ${}^\alpha v$ describes some set $V \subseteq \mathcal{V}$ (\mathcal{V} is the set of all concrete states), then it is also a safe description of any superset $V' \supseteq V$. The *concretization function* $\gamma: {}^\alpha\mathcal{V} \rightarrow 2^{\mathcal{V}}$ maps every abstract state to the smallest set of concrete states that it describes. Conversely, also every set of concrete states has a ‘best’, or most precise description. This is formalized via an *abstraction function* $\alpha: 2^{\mathcal{V}} \rightarrow {}^\alpha\mathcal{V}$. For each $V \subseteq \mathcal{V}$, $\alpha(V)$ is the most precise description in the sense that $V \supseteq \gamma(\alpha(V))$ and $V \supseteq \gamma({}^\alpha v)$ imply $\gamma(\alpha(V)) \supseteq \gamma({}^\alpha v)$ for any ${}^\alpha v \in {}^\alpha\mathcal{V}$. Thus, $\alpha(V)$ is the least description of V w.r.t. the *approximation ordering* \sqsubseteq on ${}^\alpha\mathcal{V}$ defined by “ ${}^\alpha v \sqsubseteq {}^\alpha v'$ iff $\gamma({}^\alpha v) \supseteq \gamma({}^\alpha v')$ ”. A given γ uniquely determines an appropriate α (if it exists) by setting $\alpha(V)$ to be the least (w.r.t. \sqsubseteq) ${}^\alpha v$ such that $\gamma({}^\alpha v) \subseteq V$. We mention that, similarly, α determines a unique appropriate γ as well.

These requirements are often captured by saying that (α, γ) is a *Galois insertion* from $(2^{\mathcal{V}}, \supseteq)$ to $({}^\alpha\mathcal{V}, \sqsubseteq)$: (i) α and γ are total and monotonic, (ii) for every $V \in 2^{\mathcal{V}}$ we have $(\gamma \circ \alpha)(V) \subseteq V$, and (iii) for every ${}^\alpha v \in {}^\alpha\mathcal{V}$ we have $(\alpha \circ \gamma)({}^\alpha v) = {}^\alpha v$.

Given such an abstract interpretation of the data, functions $f: \mathcal{V} \rightarrow \mathcal{V}$ can be described by

safe abstract interpretations $\alpha f: \alpha \mathcal{V} \rightarrow \alpha \mathcal{V}$ that satisfy $\alpha(f(\gamma(\alpha v))) \sqsubseteq \alpha f(\alpha v)$.¹ In particular, there is an *optimal* abstract interpretation of f defined by $\overline{\alpha f} = \alpha \circ f \circ \gamma$, and αf is safe just in case $\overline{\alpha f} \sqsubseteq \alpha f$ (pointwise). So, for functions, safeness means that given a description of the parameter, αf yields a description of the result value.

A static analysis can then be viewed as an abstract evaluation of a property φ in which data and operations of the program are abstractly interpreted, yielding a description of any concrete evaluation of φ .

3 μ -calculus and its interpretation

The (propositional) μ -calculus generalizes a number of possibly better-known logics such as CTL, LTL and CTL*, as shown in [Dam94]. For us, its main advantage is its computational nature. The basic modalities of the logic express properties of the successors of states and every constraint on the computations of a system must be explicitly coded in terms of extremal fixed points. Indeed, the basic symbolic model checking procedure can be almost immediately read-off from the satisfaction definition.

Let \mathcal{A} be some set of atomic propositions and \mathcal{X} a set of variables. Moreover, let $a \in \mathcal{A}$ and $x \in \mathcal{X}$. The syntax of the formulae of $\mu L(\mathcal{A})$ is defined by

$$\varphi ::= \varphi_1 \vee \varphi_2 \mid \varphi_1 \wedge \varphi_2 \mid \Box \varphi \mid \Diamond \varphi \mid \mu x. \varphi \mid \nu x. \varphi \mid a \mid \neg a \mid x .$$

A formula $\Box \varphi$ expresses that φ is true for every (immediate) successor while $\Diamond \varphi$ expresses that there is at least one successor for which φ is true. The least and greatest fixed point operators are $\mu x.$ and $\nu x.$.

Note that formulae are in *negation normal form*: negations may only appear in front of propositions. Because of the dualities between the pairs $\vee, \wedge, \Box, \Diamond$ and $\mu x., \nu x.$ ² there is no loss of expressiveness.

As an example, the LTL formulae Fa (on every maximal execution path, eventually the proposition a holds) and Ga (the proposition a holds always) would be translated as $\mu x.(a \vee \Box x)$ ³ and $\nu x.(a \wedge \Box x)$. We use the \Box modality because LTL formulae express properties about all paths.

$\mu L(\mathcal{A})$ is interpreted w.r.t. to a *Kripke structure* $\mathcal{M} = (\mathcal{V}, R, \mathcal{I})$. \mathcal{V} is a set of states, $R \subseteq \mathcal{V} \times \mathcal{V}$ is a total transition relation and $\mathcal{I}: \mathcal{A} \rightarrow 2^{\mathcal{V}}$ is the interpretation of the atomic propositions. The semantics of the μ -calculus maps a formula φ to the set of states for which φ is true, depending on an environment, e , mapping variables to sets of states. The semantics is defined

¹ $f(C) = \{f(c) \mid c \in C\}$.

² $\neg(\varphi \vee \psi) \equiv \neg\varphi \wedge \neg\psi$, $\neg\Box\varphi \equiv \Diamond\neg\varphi$ and $\neg\mu x.\varphi \equiv \nu x.\neg\varphi[\neg x/x]$.

³ Assuming that there are no deadlocked states

as a function, $\llbracket \cdot \rrbracket$, of type:

$$\begin{aligned} \varphi \rightarrow (\mathcal{X} \rightarrow 2^{\mathcal{V}}) &\rightarrow 2^{\mathcal{V}} \text{ such that} \\ \llbracket a \rrbracket e &= \mathcal{I}(a) \\ \llbracket \neg a \rrbracket e &= \mathcal{V} \setminus \mathcal{I}(a) \\ \llbracket x \rrbracket e &= e(x) \\ \llbracket \varphi_1 \vee \varphi_2 \rrbracket e &= \llbracket \varphi_1 \rrbracket e \cup \llbracket \varphi_2 \rrbracket e \\ \llbracket \varphi_1 \wedge \varphi_2 \rrbracket e &= \llbracket \varphi_1 \rrbracket e \cap \llbracket \varphi_2 \rrbracket e \\ \llbracket \diamond \varphi \rrbracket e &= \tau_{\diamond}(\llbracket \varphi \rrbracket e) \\ \llbracket \square \varphi \rrbracket e &= \tau_{\square}(\llbracket \varphi \rrbracket e) \\ \llbracket \mu x. \varphi \rrbracket e &= \bigcap \{V \subseteq \mathcal{V} \mid \llbracket \varphi \rrbracket e[V/x] \subseteq V\} \\ \llbracket \nu x. \varphi \rrbracket e &= \bigcup \{V \subseteq \mathcal{V} \mid V \subseteq \llbracket \varphi \rrbracket e[V/x]\} \end{aligned}$$

with

$$\begin{aligned} \tau_{\diamond}: 2^{\mathcal{V}} &\rightarrow 2^{\mathcal{V}} \\ U &\mapsto \text{pre}_R(U) = \{v \in \mathcal{V} \mid \exists u \in U : R(v, u)\} \\ \tau_{\square}: 2^{\mathcal{V}} &\rightarrow 2^{\mathcal{V}} \\ U &\mapsto \widetilde{\text{pre}}_R(U) = \mathcal{V} \setminus \text{pre}(\mathcal{V} \setminus U) = \{v \in \mathcal{V} \mid \forall u \in \mathcal{V} : R(v, u) \Rightarrow u \in U\} \end{aligned}$$

As every φ is monotonic the greatest ($\nu x. \varphi$) and least ($\mu x. \varphi$) fixed points exists ([Tar55]).

Write $\llbracket \cdot \rrbracket_{\mathcal{M}}$ to make the intended Kripke structure explicit. For closed⁴ φ , we have $\mathcal{M}, v \models \varphi$ just in case $v \in \llbracket \varphi \rrbracket_{\perp}$ where \perp is the environment that maps every $x \in \mathcal{X}$ to \emptyset .

4 Binary decision diagrams

Reduced Ordered Binary Decision Diagrams (BDD's) [Bry86, Bry92] are a way to economically represent boolean functions in a canonical way. Although for most boolean functions the size of their BDD representation is exponentially large, in many practical cases the BDDs are sufficiently small. This, together with the fact that boolean operations, equivalence and tautology checking can be done very efficiently on BDDs, is the reason why BDDs are so popular. BDDs only supply a canonical representation relative to an arbitrary but fixed ordering on the boolean (input) variables and this ordering greatly influences the size of the BDDs.

The use of BDDs in model checking is based on coding transition relations as boolean functions. Given a transition relation $R \subseteq \mathcal{V} \times \mathcal{V}$, take vectors \vec{x}, \vec{x}' of boolean variables long enough to code for all states in \mathcal{V} (e.g., take $|\vec{x}|, |\vec{x}'| \geq \log(|\mathcal{V}|)$). Then, define a boolean function $\ulcorner R \urcorner(\vec{x}, \vec{x}')$ ⁵ by

$$\ulcorner R \urcorner(\vec{x}, \vec{x}') = 1 \iff \exists v, v' \in \mathcal{V} \ R(v, v') \wedge \beta(v) = \vec{x} \wedge \beta(v') = \vec{x}' ,$$

where β is the coding function that maps states to bit strings.

⁴A formula is closed if every variable occurring in it is bound by a fixed point operator.

⁵We usually do not make a distinction between the boolean function $\ulcorner R \urcorner$ and its BDD representation.

4.1 Symbolic model checking

Symbolic model checking is based on such BDD representations [CBM90]. The basic, non-logical operation that needs to be done is computing preconditions, $\text{pre}_R(V)$, which translates into computing *relational products*: $\exists \vec{x}' (\ulcorner R \urcorner(\vec{x}, \vec{x}') \wedge \ulcorner V \urcorner(\vec{x}'))$. Obviously, to represent a set as a BDD we use its characteristic predicate. This is used in representing the interpretation function \mathcal{I} as well.

To symbolically model check a μ -calculus formula φ over a Kripke structure \mathcal{M} , we compute the characteristic predicate of $\llbracket \varphi \rrbracket_{\perp}$. Hence

$$v \in \llbracket \varphi \rrbracket_{\mathcal{M}} \perp \text{ iff } \beta(v) \in \ulcorner \llbracket \varphi \rrbracket_{\mathcal{M}} \urcorner \perp .$$

We follow the definition of $\llbracket \cdot \rrbracket$: Boolean connectives translate to the corresponding boolean operations on the BDDs of the (immediate) subformulae. For formulae of the form $\diamond \varphi$ we compute $\text{pre}_R(\ulcorner \llbracket \varphi \rrbracket \urcorner)$ using a relational product; likewise for $\square \varphi$ formulae. Fixed points are computed iteratively as usual, by successively computing their approximations until they stabilize. E.g., a least fixed point is computed as

$$\begin{aligned} \ulcorner \llbracket \mu x. \varphi \rrbracket \urcorner e &= \ulcorner \llbracket \mu x. \varphi \rrbracket \urcorner^{\infty} e \\ \text{where } \ulcorner \llbracket \mu x. \varphi \rrbracket \urcorner^0 e &= \text{ff} \text{ and} \\ \ulcorner \llbracket \mu x. \varphi \rrbracket \urcorner^{i+1} e &= \ulcorner \llbracket \mu x. \varphi \rrbracket \urcorner^i e \vee \ulcorner \llbracket \varphi \rrbracket \urcorner e [x \mapsto \ulcorner \llbracket \mu x. \varphi \rrbracket \urcorner^i e] \end{aligned}$$

If the Kripke structure \mathcal{M} is finite, this procedure will terminate after at most $|\mathcal{M}|$ iterations. In practice, techniques such as *iterative squaring* are used to (exponentially) speed-up the fixed-point computations (see [BCM⁺92]).

5 Programs

Let \mathcal{S} be the set of *local states*. A program P either has the form $P' \parallel P''$, for programs P' and P'' or is a labeled transition system (lts) $(\mathbf{S}, \ell, \mathbf{I})$ with $\mathbf{S} \subseteq \mathcal{S}$. The latter is also called a *process*. Here, $\ell: \mathbf{S} \times \mathbf{S} \rightarrow \mathcal{L}(\mathcal{S})$, where $\mathcal{L}(\mathcal{S})$ denotes the propositional logic over the set of ‘propositions’ \mathcal{S} . The intuition is that a ‘transition’ (s, s') with label $\ell(s, s')$ in P is enabled if the global starting state (in which P is ‘at’ s) satisfies the constraint expressed by the label. $\mathbf{I} \subseteq \mathbf{S}$ is the set of initial states. Figure 1 gives an example. The lts P on the right-hand-side is equivalent with $\llbracket P^0 \parallel P^1 \rrbracket$ (as will be defined below). Observe that parallel processes execute synchronously.

Although such programs may look unfamiliar, they correspond to simplified Statechart models [Har87] in which no events are broadcast. Indeed, the test $\neg(t_1 \vee t_2)$ in Figure 1 corresponds to the Statechart condition $\llbracket \text{not}(\text{IN}(t_1) \text{ or } \text{IN}(t_2)) \rrbracket$. The verifier that we have implemented deals with full Statecharts.

For convenience we want to view (global) states of parallel processes as *sets* of local states⁶. For this reason, we assume that

⁶Hence, we identify $\{ \{s\} \mid s \in \mathbf{S} \}$ with the local states of an lts $(\mathbf{S}, \ell, \mathbf{I})$.

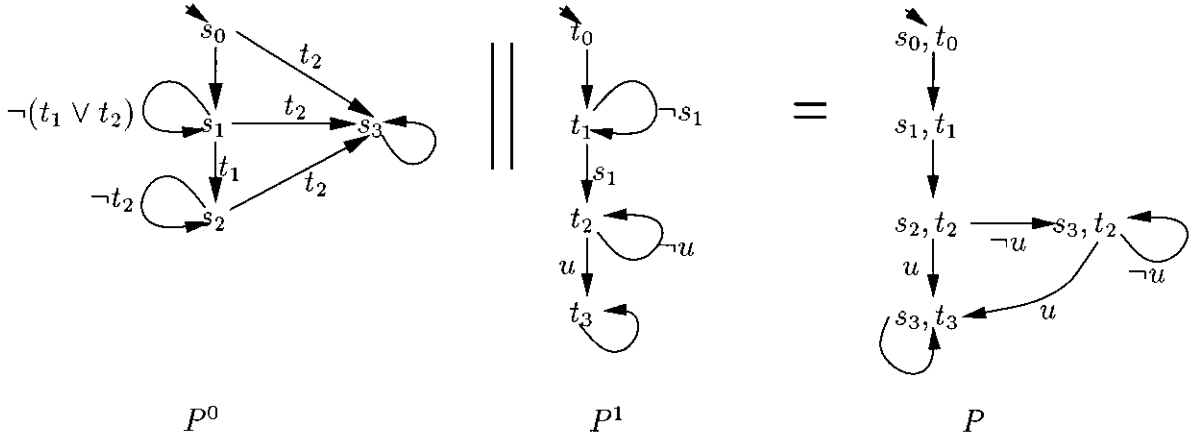

Figure 1: Example program

- If $P = P' \parallel P''$ then $S' \cap S'' = \emptyset$ for every $S' \in \mathcal{S}(P')$ and $S'' \in \mathcal{S}(P'')$; $\mathcal{S}(Q)$ stands for the set of states of Q .

Because of this constraint, program states can be taken from $2^{\mathcal{S}}$; one local state per component. For $S \in 2^{\mathcal{S}}$ and $\varphi \in \mathcal{L}(\mathcal{S})$, $S \models \varphi$ is defined as usual and $S \models s$ iff $s \in S$. If $P^0 = (\mathbf{S}^0, \ell^0, \mathbf{I}^0)$ and $P^1 = (\mathbf{S}^1, \ell^1, \mathbf{I}^1)$ are lts's, then $P^0 \parallel P^1$ determines an lts, $\llbracket P^0 \parallel P^1 \rrbracket = (\mathbf{S}, \ell, \mathbf{I})$, as follows:

- $\mathbf{S} = \{S^0 \cup S^1 \mid S^0 \in \mathbf{S}^0, S^1 \in \mathbf{S}^1\}$ and $\mathbf{I} = \{I^0 \cup I^1 \mid I^0 \in \mathbf{I}^0, I^1 \in \mathbf{I}^1\}$,
- $\ell = \ell^0 \parallel \ell^1$ defined by $(\ell^0 \parallel \ell^1)(S, S') = \ell^0(S^0, S^{0'})[\mathbf{tt}/S^1] \wedge \ell^1(S^1, S^{1'})[\mathbf{tt}/S^0]$, where $[\mathbf{tt}/T]$ substitutes \mathbf{tt} for every state in $T \in 2^{\mathcal{S}}$, $S = S^0 \cup S^1$, $S' = S^{0'} \cup S^{1'}$, $S^0, S^{0'} \subseteq \mathbf{S}^0$ and $S^1, S^{1'} \subseteq \mathbf{S}^1$ (remember that $\forall S^0 \subseteq \mathbf{S}^0, S^1 \subseteq \mathbf{S}^1 : S^0 \cap S^1 = \emptyset$).

As an example, consider Figure 1 again. The label of the $\{s_2, t_2\} - \{s_3, t_3\}$ transition is obtained as $\ell^0(s_2, s_3)[\mathbf{tt}/\{t_2\}] \wedge \ell^1(t_2, t_3)[\mathbf{tt}/\{s_2\}] \equiv t_2[\mathbf{tt}/\{t_2\}] \wedge u[\mathbf{tt}/\{s_2\}] \equiv \mathbf{tt} \wedge u \equiv u$.

An lts $P = (\mathbf{S}, \ell, \mathbf{I})$ induces a ‘standard’ transition relation, R^ℓ , on the global state space, as follows. Let $S, S' \in \mathbf{S}$ be local states of P and consider global states $S \cup T$ and $S' \cup T'$ ($T, T' \in 2^{\mathcal{S}}$), i.e., whose P -components are S and S' resp. Then

$$R^\ell(S \cup T, S' \cup T') \text{ iff } S \cup T \models \ell(S, S').$$

For technical reasons, we also impose the constraint

- For any labeled transition system $(\mathbf{S}, \ell, \mathbf{I})$ the transition relation must be total:

$$\models \bigvee_{S' \in \mathbf{S}} \ell(S, S') \text{ for every } S \in \mathbf{S}.$$

Its consequence is that programs can never deadlock. I.e., in every global state there is at least one (globally) enabled transition in every process of the program.

Lemma 5.1 *With notation as above*

- \parallel is commutative and associative; i.e., $\llbracket P^0 \parallel P^1 \rrbracket = \llbracket P^1 \parallel P^0 \rrbracket$ and $\llbracket P^0 \parallel (P^1 \parallel P^2) \rrbracket = \llbracket (P^0 \parallel P^1) \parallel P^2 \rrbracket$.
- If P is a program then $\llbracket P \rrbracket$ has a total transition relation.
- For lts's P^0 and P^1 , $R^\ell = R^{\ell^0} \cap R^{\ell^1}$

Proof. The first point is a direct consequence of commutativity and associativity of the operators \cup and \wedge in the definition of $\llbracket \cdot \rrbracket$. The second point is easily proven by induction over the structure of programs.

For the third point, let $P^0 = (\mathbf{S}^0, \ell^0, \mathbf{I}^0)$ and $P^1 = (\mathbf{S}^1, \ell^1, \mathbf{I}^1)$, $S^0, S^{0'} \in \mathbf{S}^0$, $S^1, S^{1'} \in \mathbf{S}^1$, and $T, T' \in 2^{\mathcal{S}}$ (such that for each $S \in \mathbf{S}^0 \cup \mathbf{S}^1$, $T \cap S = \emptyset$ and $T' \cap S = \emptyset$). Assume $R^\ell(S^0 \cup S^1 \cup T, S^{0'} \cup S^{1'} \cup T')$. By the definitions of R^ℓ and $\ell^0 \parallel \ell^1$, this is equivalent to $S^0 \cup S^1 \cup T \models \ell^0(S^0, S^{0'})[\mathbf{tt}/S^1] \wedge \ell^1(S^1, S^{1'})[\mathbf{tt}/S^0]$. Because $S^i \models s^i$ for every $s^i \in S^i$ ($i = 0, 1$), this implies $S^0 \cup S^1 \cup T \models \ell^0(S^0, S^{0'})$ and $S^0 \cup S^1 \cup T \models \ell^1(S^1, S^{1'})$. Furthermore, the reverse implication is obvious. By the definitions of R^{ℓ^0} and R^{ℓ^1} , $S^0 \cup S^1 \cup T \models \ell^0(S^0, S^{0'})$ and $S^0 \cup S^1 \cup T \models \ell^1(S^1, S^{1'})$ reduce to $R^{\ell^0}(S^0 \cup S^1 \cup T, S^{0'} \cup S^{1'} \cup T')$ and $R^{\ell^1}(S^0 \cup S^1 \cup T, S^{0'} \cup S^{1'} \cup T')$. \square

Hence, program semantics is well-defined.

Finally, we define when a program satisfies a $\mu L(\mathcal{S})$ -formula:

Definition 5.2 *A program P with $\llbracket P \rrbracket = (\mathbf{S}, \ell, \mathbf{I})$ induces a Kripke structure $\mathcal{M}_P = (2^{\mathcal{S}}, R^\ell, \mathcal{I})$ where $\mathcal{I}(s) = \{S \in 2^{\mathcal{S}} \mid s \in S\}$ for every $s \in \mathcal{S}$. For any $\mu L(\mathcal{S})$ formula φ define $P \models \varphi$ by $\mathbf{I} \subseteq \llbracket \varphi \rrbracket_{\mathcal{M}_P} \perp$.*

So, e.g., the program in Figure 1 would satisfy $P \models \mu x.((s_2 \wedge t_2) \vee \Diamond x)$; i.e., the s_2, t_2 -state is reachable. Indeed, $\llbracket \mu x.((s_2 \wedge t_2) \vee \Diamond x) \rrbracket \perp$ includes the initial state of P .

6 Program abstractions

Although all the ingredients are in place to build a symbolic model checker, experience shows that in practice it would have limited applicability. The main problem is the amount of memory needed to store the BDDs that describe the program's transition relation and that describe the intermediate results during the computation of $\llbracket \varphi \rrbracket_{\mathcal{M}}$. Also, since the time complexity of BDD operations are low order polynomial in the size of the BDDs they operate on, model checking time is affected as well.

The abstract interpretation framework suggests two ways to reduce the time and space requirements. One can replace the set $(2^{\mathcal{S}})$ of concrete states by a smaller set 2^D of abstract states so that fewer BDD variables are needed to represent subsets of D . Also, although

given an abstract domain the concrete functions are often replaced by their optimal abstract interpretations, one can use safe approximations that are easier to compute instead.

Next, observe that a large set does not imply that the BDD representation of its characteristic predicate has a large number of BDD nodes as well. The set of all states is a case in point: it is represented by the 1 node BDD $\ulcorner \text{tt} \urcorner$. Thus our aim should not be to reduce the size of the state sets but to reduce the number of nodes in the BDDs representing these sets.

Now, given a program P (or rather the Kripke structure induced by it), the representations of the semantics of the propositions are very small, although the represented sets can be quite large. Indeed, each proposition describes just a single local state of a process in P . The computation of conjunction and disjunction are of polynomial time and space and the computation of the fixpoints is just an iteration. The point where the BDD representations of the intermediate sets become large is during the computation of the relational product with the transition relation—computing τ_{\diamond} respectively τ_{\square} . From these observations we conclude that the set of abstract states D need not be different (smaller) than S in order to reduce time and space during BDD-based model checking, but that the abstract operators ${}^{\alpha}\tau_{\diamond}$ and ${}^{\alpha}\tau_{\square}$ should lead to sets with smaller BDD-representations than the original ones.

Thus our abstract interpretation, ${}^{\alpha}[\cdot]$, of $\mu L(S)$ takes ${}^{\alpha}\mathcal{V} = 2^{\mathcal{S}}$ as abstract domain and replaces only the τ_{\square} and τ_{\diamond} functions by safe abstract interpretations ${}^{\alpha}\tau_{\square}$ and ${}^{\alpha}\tau_{\diamond}$ in the definition on page 4. Hence, the other operations are ‘replaced’ by their optimal interpretations.

Lemma 6.1 *If ${}^{\alpha}\tau_{\square}$ and ${}^{\alpha}\tau_{\diamond}$ are safe interpretations, i.e., if ${}^{\alpha}\tau_{\square}(S) \subseteq \tau_{\square}(S)$ and ${}^{\alpha}\tau_{\diamond}(S) \subseteq \tau_{\diamond}(S)$ for $S \in 2^{\mathcal{S}}$ then*

$${}^{\alpha}[\varphi]e \subseteq [\varphi]e \quad \text{for any } \varphi \text{ and } e .$$

Proof. Straightforward. The essential point is that all operations in the definition of $[\cdot]$ on page 4 are monotonic (except for the negation—but it is only applied to propositions). \square

Hence, using such abstractions, we may erroneously conclude that $P \not\models \varphi$, but if $\mathbf{I} \subseteq {}^{\alpha}[\varphi]\perp$ then $P \models \varphi$ holds.

In the concrete case τ_{\square} and τ_{\diamond} are computed from the transition relation R as relational products. This is possible for the abstract versions as well, except that two different transition relations are needed:

Lemma 6.2 $\text{pre}_{R'} \subseteq \text{pre}_R$ if $R' \subseteq R$ and $\widetilde{\text{pre}}_{R''} \subseteq \widetilde{\text{pre}}_R$ if $R \subseteq R''$

Write $\ell' \preceq \ell$ in case $R^{\ell'} \subseteq R^{\ell}$.

We can, in fact, compute abstractions compositionally:

Lemma 6.3 *If $\ell'_i \preceq \ell_i$ ($i = 0, 1$) then $\ell'_0 \parallel \ell'_1 \preceq \ell_0 \parallel \ell_1$.*

Proof. Follows from the third point of Lemma 5.1. \square

For, e.g., $P^0 \parallel P^1$, $\lceil \text{pre}_{R^{\ell^0 \parallel \ell^1}}(C) \rceil$ would be computed as the relational product $\exists \bar{x}' (\lceil R^{\ell^0} \rceil(\bar{x}, \bar{x}') \wedge \lceil R^{\ell^1} \rceil(\bar{x}, \bar{x}') \wedge \lceil C \rceil(\bar{x}'))$ and the global transition relation $R^{\ell^0 \parallel \ell^1}$ is not explicitly represented by a BDD.

6.1 Abstraction from interactions

A relational product grows large if there is much interaction between the various processes⁷. Accordingly, the idea behind our abstractions is to reduce such interactions.

So, a universal abstraction replaces the (satisfiable) constraints on some transitions by **tt**, while an existential abstraction removes some edges with non-trivial constraints. As a consequence, the abstracted part is no longer influenced by the other processes. Also, its influence on the non-abstracted processes is ‘simplified’.

Definition 6.4 *Let P be an lts $(\mathbf{S}, \ell, \mathbf{I})$. An abstraction of P is determined by selecting a subset $S_A \subseteq \mathbf{S}$. Define $\alpha \ell_{\square}(S, S') \stackrel{D}{=} \mathbf{tt}$ if $S, S' \in S_A$ and $\not\models \neg \ell(S, S')$; define $\alpha \ell_{\diamond}(S, S') \stackrel{D}{=} \mathbf{ff}$ if $S, S' \in S_A$ and $\not\models \ell(S, S')$. Elsewhere, $\alpha \ell_{\square}$ and $\alpha \ell_{\diamond}$ coincide with ℓ . Then the universal abstraction is $\alpha P_{\square} \stackrel{D}{=} (\mathbf{S}, \alpha \ell_{\square}, \mathbf{I})$; the existential abstraction is $\alpha P_{\diamond} \stackrel{D}{=} (\mathbf{S}, \alpha \ell_{\diamond}, \mathbf{I})$*

The condition $\not\models \neg \ell(S, S')$ in the definition of $\alpha \ell_{\square}$ is included to ensure that no new transition is added between two states S and S' if there was no transition at all (i.e., $\models \neg \ell(S, S')$ would hold for these states) before. Similarly, the condition $\not\models \ell(S, S')$ in the definition of $\alpha \ell_{\diamond}$ prevents from disappearing those transitions which have tautological constraints.

We shall often write $\alpha R_{\square}^{\ell}$ instead of $R^{\alpha \ell_{\square}}$, etc.

Lemma 6.5 *With notation as above, $\alpha \ell_{\diamond} \preceq \ell$ and $\ell \preceq \alpha \ell_{\square}$.*

How good are these abstractions; i.e., can we often find abstractions that both offer substantial reduction and allow many properties to be verified? This is difficult to assess in general but, heuristically, the universal abstraction ($\alpha \ell_{\square}$) is often more usable than the existential one. This is because in the lattice of relations, program relations tend to be closer to the empty relation than they are to the full one. Indeed, a program describes the allowed behavior rather than those behaviors that are disallowed. E.g., a function for computing, say, the square root of its input, is usually not implemented by a program that admits arbitrary behavior only constrained by the requirement that it computes the square root. Quite the opposite: a square root program should only perform those actions that are necessary for its correct functioning. This means that there tends to be ample room to add transitions to a relation—as a universal abstraction does—without hitting the full relation, but less so to remove them. The effect of this is that it tends to be easier to find a universal abstraction that preserves the truth of a universal property (i.e., a property that does not use \diamond -modalities) than it is to find a usable existential abstraction that preserves an existential property. Indeed, from the 13 properties that use \diamond -modalities on page 15 none could be verified using existential abstractions alone.

⁷This observation can be made more precise if we look at the particular way states are encoded.

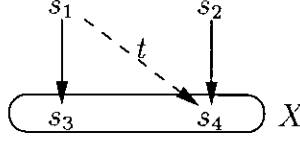

Figure 2: Universal abstraction functioning as an existential one

6.2 A better existential abstraction

Specifically, as we compute $\alpha R_{\square}^{\ell}$ anyway, is it possible to use $\alpha R_{\square}^{\ell}$ for existential abstractions as well? First, observe that on the **unabstracted** part of a process's transition relation $\alpha R_{\diamond}^{\ell} = R = \alpha R_{\square}^{\ell}$; on the abstracted part we have $\alpha R_{\diamond}^{\ell} \subseteq R \subseteq \alpha R_{\square}^{\ell}$. However, as long as $\text{pre}_{\alpha R_{\square}^{\ell}}(S) \subseteq \text{pre}_R(S)$ for sets S that arise as intermediate results, this will cause no problems. That this is possible is illustrated in Figure 2. The label on the dashed transition will be removed by a universal abstraction $\alpha R_{\square}^{\ell}$ (for $S_A = \{s_i \mid i = 1 \dots 4\}$). However, obviously $\text{pre}_{\alpha R_{\square}^{\ell}}(X) \subseteq \text{pre}_R(X) = \{s_1, s_2\}$. Lemma 6.7 below characterizes these situations.

First we need a notion of *independency*. Intuitively, a set of global states X is *independent* of a set of local states S of a process P , if the other processes being in a state in X does not depend on P being in a specific local state in $X \cap S$.

For example, considering Figure 3 on page 12, let \mathbf{S} be the local states of the left-hand-side process, and let $S = \{s_0, s_1, s_2\}$. Then $\{\{s_0, t_0\}, \{s_0, t_1\}, \{s_1, t_1\}, \{s_2, t_1\}\}$ is not independent of S because the local state t_0 only occurs with s_0 (which is in S) but not with the other local states in S . Both $\{\{s_0, t_1\}, \{s_1, t_1\}, \{s_2, t_1\}\}$ and $\{\{s_0, t_0\}, \{s_1, t_0\}, \{s_2, t_0\}, \{s_0, t_1\}, \{s_1, t_1\}, \{s_2, t_1\}\}$ are independent however.

Definition 6.6 Let $\mathbf{S} \subseteq \mathcal{S}$ be the set of local states of a single process and let $S \subseteq \mathbf{S}$.

- For a set $X \subseteq 2^{\mathcal{S}}$ of global states, X is independent of S if for each $x \in X$ with $x \cap \mathbf{S} \in S$ and $x \cap (\mathcal{S} \setminus \mathbf{S}) = t$, we have $\forall s \in S : s \cup t \in X$.
- $\text{Suc}(S) = \{s' \in \mathbf{S} \mid \exists s \in S \not\models \neg \ell(s, s')\}$.

Now, the situations as in Figure 2 can be characterized:

Lemma 6.7 Let S_A determine an abstraction of the lts $(\mathbf{S}, \ell, \mathbf{I})$. For any $X \subseteq 2^{\mathcal{S}}$ which is independent of $S_A \cup \text{Suc}(S_A)$ we have $\text{pre}_{\alpha R_{\square}^{\ell}}(X) \subseteq \text{pre}_R(X)$.

Proof. Let $y \in \text{pre}_{\alpha R_{\square}^{\ell}}(X)$. So, we can choose $x \in X$ such that $\alpha R_{\square}^{\ell}(y, x)$, whence $y \models \alpha \ell_{\square}(y \cap \mathbf{S}, x \cap \mathbf{S})$.

If $x \cap \mathbf{S} \notin S_A$ or $y \cap \mathbf{S} \notin S_A$ then, by definition of $\alpha \ell_{\square}$, $\alpha \ell_{\square}(y, x) = \ell(y, x)$ so that $R^{\ell}(y, x)$, whence $y \in \text{pre}_R(X)$.

Suppose $x \cap \mathbf{S} \in S_A$ and $y \cap \mathbf{S} \in S_A$. If in addition $R^\ell(y, x)$, then we are ready. Suppose $\neg R^\ell(y, x)$. So, $y \models \alpha_{\square}^\ell(y \cap \mathbf{S}, x \cap \mathbf{S})$ but not $y \models \ell(y \cap \mathbf{S}, x \cap \mathbf{S})$. We look for $x' \in X$ such that $y \models \ell(y \cap \mathbf{S}, x' \cap \mathbf{S})$. As X is independent of $S_A \cup \text{Suc}(S_A)$ while $x \cap \mathbf{S} \in S_A \cup \text{Suc}(S_A)$, we can choose $x' \in X$ so that $x' \cap (\mathcal{S} \setminus \mathbf{S}) = x \cap (\mathcal{S} \setminus \mathbf{S})$ and $x' \cap \mathbf{S} \in S_A \cup \text{Suc}(S_A)$. Furthermore, by totality of ℓ , we can choose x' in such a way that $y \models \ell(y \cap \mathbf{S}, x' \cap \mathbf{S})$. So, $R^\ell(y, x')$ holds and, hence, $y \in \text{pre}_{R^\ell}(X)$. \square

For a given S_A as above, define $\Gamma: 2^{2^{\mathcal{S}}} \rightarrow 2^{2^{\mathcal{S}}}$ such that $\Gamma(\mathbf{T})$ is the (unique) largest subset of \mathbf{T} that is independent of $S_A \cup \text{Suc}(S_A)$. So, for the example in Figure 3, $\Gamma(\{\{s_i, t_j\} \mid (i < 3 \wedge j = 0) \vee (i < 4 \wedge j = 1)\}) = \{\{s_i, t_j\} \mid i < 4 \wedge j = 1\}$. We have

Corollary 6.8 *For any $X \subseteq 2^{\mathcal{S}}$, $\text{pre}_{\alpha_{R^\ell}}(\Gamma(X)) \subseteq \text{pre}_{R^\ell}(X)$.*

Hence, $\text{pre}_{\alpha_{R^\ell}} \cup (\text{pre}_{\alpha_{R^\ell}} \circ \Gamma)$ is a safe approximation of τ_{\diamond} .

Figure 3 shows an example in which both existential pre-abstractions are needed. Write $\alpha_{\text{pre}_{\diamond}}$ and $\alpha_{\text{pre}_{\square}}$ for the approximations to pre induced by Definition 6.4; write $\alpha_{\overline{\text{pre}}_{\diamond}}$ for $\alpha_{\text{pre}_{\diamond}} \cup (\alpha_{\text{pre}_{\square}} \circ \Gamma)$. The states within the dashed boundary are abstracted. So, α_{R^ℓ} will remove the t_1 label between s_1 and s_2 and the labels on the self-loops at s_1 and s_2 while α_{R^ℓ} will remove the corresponding transitions. In computing $\alpha[\Phi]$ we use the iterative scheme of page 5. We start with $\alpha[\Phi]^1 \perp = \alpha[t_3] = \{S \subseteq \mathcal{S} \mid t_3 \in S\}$. For the set on the right-hand-side we just write t_3 ; this being its characteristic predicate. As $\alpha_{\text{pre}_{\diamond}}(t_3) = t_2 \vee (t_3 \wedge (s_0 \vee s_3))$, $\alpha_{\text{pre}_{\square}}(t_3) = t_2 \vee t_3$ and $\Gamma(t_3) = t_3$, we obtain $\alpha[\Phi]^2 \perp = t_3 \vee \alpha_{\overline{\text{pre}}_{\diamond}}(t_3) = t_3 \vee \alpha_{\text{pre}_{\diamond}}(t_3) \vee \alpha_{\text{pre}_{\square}}(\Gamma(t_3)) = t_2 \vee t_3$. Next, we compute $\alpha[\Phi]^3 \perp = t_3 \vee \alpha_{\overline{\text{pre}}_{\diamond}}(t_2 \vee t_3)$. Because both $\alpha_{\text{pre}_{\diamond}}$ and Γ distribute over disjunction, this equals $t_3 \vee \alpha_{\text{pre}_{\diamond}}(t_2) \vee \alpha_{\text{pre}_{\diamond}}(t_3) \vee \alpha_{\text{pre}_{\square}}(\Gamma(t_2) \vee \Gamma(t_3))$. As $\alpha_{\text{pre}_{\diamond}}(t_2) = \emptyset$, $\Gamma(t_2) = t_2$ and $\alpha_{\text{pre}_{\square}}(t_2 \vee t_3) = (t_1 \wedge s_1) \vee t_2 \vee t_3$, we get $(t_1 \wedge s_1) \vee t_2 \vee t_3$ as the result. Now, $\Gamma(t_2 \vee t_3 \vee (s_1 \wedge t_1)) = t_2 \vee t_3$ so that for computing $\alpha_{\overline{\text{pre}}_{\diamond}}$ at $t_2 \vee t_3 \vee (s_1 \wedge t_1)$, $\alpha_{\text{pre}_{\square}}$ does not contribute. However, we do have $\{s_0, t_0\} \in \alpha_{\text{pre}_{\diamond}}(\{s_1, t_1\})$ and by this $\{s_0, t_0\} \in \alpha[\Phi]^4 \perp$.

7 Experimental results

We applied the abstraction techniques developed above to verify a production cell [DHKS95]. Figure 4 depicts the system to model.

The task of the production cell is to press metal blanks. The production cell consists of two conveyor belts (the *feed belt* in the front and the *deposit belt* in the back of the picture), a rotary table (right to the feed belt), a press (to the right of the picture), a robot with two independent movable arms (between rotary table and press) and a crane (under the top of the picture). In addition, we assume that there is a user who puts a metal blank on the feed belt.

The controller of the production cell notifies the user when a new metal blank can be put on the feed belt. This will transport it to the rotary table. The table will rotate and lift the blank up, so it can be picked up by the first robot arm. The robot puts the blank into the press. After pressing the blank, the second robot arm fetches the pressed blank and puts it

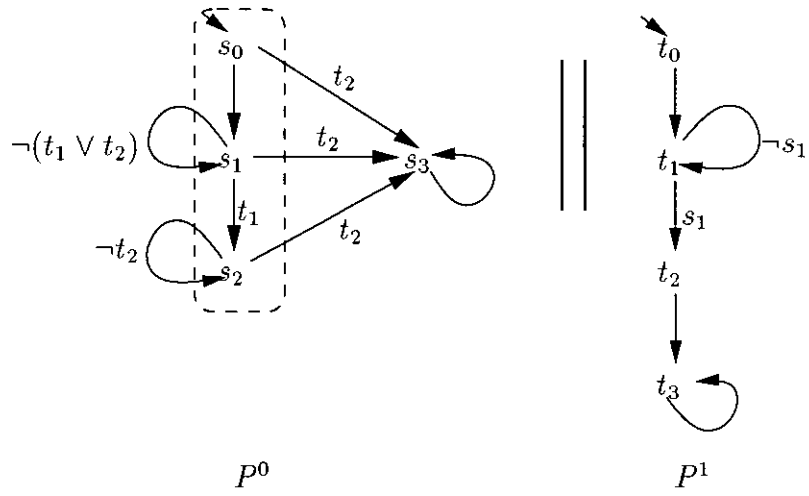

Figure 3: $(\alpha P^0 \parallel P^1) \models \Phi$ with $\Phi \stackrel{D}{=} \mu x.(t_3 \vee \diamond x)$

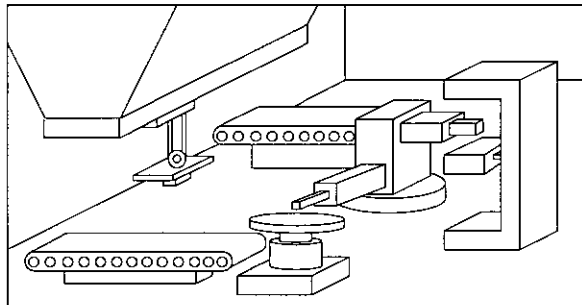

Figure 4: A production cell

on the deposit belt, which will transport the blank to the crane. The crane closes the cycle and moves the blank from the deposit belt to the feed belt in order to press the blank again.

We have modeled the production cell with StateCharts [Har87]. StateCharts is a graphical specification language. It is based on automata that can be composed in parallel and that form a hierarchy. The parallel composition leads to a (synchronous) lock-step semantics, where parallel components have to make a step if they can, otherwise they stutter. Hence, the induced transition relation is total, which is required by our framework. The parallel components of the production cell communicate by identifying states of other components, e.g., a transition from one state to another one is only possible if another process is in a certain state. By this mechanism the parallel components will be synchronized. This fragment of Statecharts corresponds to the programs we introduced in this paper. A detailed description of the translation scheme for full StateCharts into BDDs can be found in [HK94].

Since the production cell contains several physical components which have to be controlled independently, the general structure of the StateChart specification is a parallel decomposition of the controller w.r.t. the physical components. The single sub-controllers for the components are again decomposed for the single task the sub-controller has to satisfy, e.g., the sub-controller for the rotary table has again sub-controllers for the rotation and the vertical movement.

The verification of the production cell distinguishes between safety and liveness properties. Typical safety properties are that the table does not rotate too far in one of the two directions thus avoiding damage. For all controller components these kind of safety properties can be checked in isolation; i.e., the property that the table only rotates in its specified area is independent of the behavior of the robot. An abstraction of all sub-controllers except the controller for the table as described above preserves the necessary information to verify the safety property.

Liveness properties are more complex to verify because they are in general not restricted to the behavior of some few processes. For example the property that along all executions eventually the crane puts a blank on the front belt needs all processes, because this property simulates a complete run through the production cell. Using abstractions one has to split such a specification into several parts which together imply the original property but each of which only needs part of the model. However, we are able to verify the several parts individually.

The verification results are shown in the Tables 2–4 below. The first column gives the property that is checked. It is expressed using the *CTL* operators **G** (“globally”, i.e., for all states along a path), **F** (“eventually”, i.e., there exists a state along a path) as well as the **Unless** operator (also called weak until) defined by $\varphi_1 \text{Unless } \varphi_2 \equiv (\varphi_1 \text{U} \varphi_2) \vee \text{G}\varphi_1$, where **U** is the until operator. **A** and **E** denote the universal resp. existential path quantifiers. These formulae are easily translated into the μ -calculus. For example, $\text{A}(\varphi_1 \text{Unless } \varphi_2) \equiv \nu x.(\varphi_2 \vee (\varphi_1 \wedge \Box x))$. The meanings of the propositions occurring in these formulae are explained in Table 1.

The second column indicates which parts of the system have been abstracted. The entire system consists of a parallel composition of processes modelling the feed belt, rotary table, robot, press, deposit belt, crane and user; in the tables these are identified by their first letters. We always abstract from entire processes. E.g., an entry *rpd* in the second column means that robot, press and deposit belt have been abstracted from. Because of the tight

interaction of the processes this means that the existential abstractions of the processes remove *all* transitions. Indeed, none of these properties could be verified without the optimization from Section 6.2.

The third and fourth columns give the maximal number of BDD nodes that are needed to verify the property without resp. with application of our abstraction technique; the last column is the reduction factor between these numbers.

Table 3 shows that formulae with existential path quantifiers can also be verified while Table 4 gives results for formulae with mixed path quantifiers.

The most notable feature of these tables is that we are able to achieve a 17-fold reduction on the average in the number of BDD nodes needed to verify the specifications.

proposition	meaning
init	the entire system is in its initial state
f-go	the feed belt is running
f-in	there is a metal blank on the right end of the feed belt (near the rotary table)
t-hpos-f	the horizontal position of the rotary table is such that it can accept a metal blank from the feed belt
t-empty	there is no metal blank on the rotary table
t-full	there is a metal blank on the rotary table
t-vpos-bot	the vertical position of the rotary table is at its lowest point
t-vpos-err	the vertical position of the rotary table is such that it may cause damage

Table 1: Meanings of the propositions.

8 Conclusions

We have developed a compositional abstract interpretation scheme for model checking full propositional μ -calculus over parallel processes. The technique shows quite good performance in non-trivial examples, resulting in substantial reductions in the number of BDD nodes. The programming model that we consider is general and underlies many programming languages, hence we expect our results to be generally applicable. We have extended these abstraction techniques to directly apply to a larger subset of the StateChart language; notably event generation and event triggers (including triggering on the absence of events).

Future work includes the refinement of these techniques to cover a larger class of program abstractions.

property	abstract from	without abstraction	with	red. fact.
$\text{init} \Rightarrow \text{AG } \neg \text{t-vpos-err}$	<i>frpdcu</i>	36300	2210	16
$\text{init} \Rightarrow \text{AF } \text{t-full}$	<i>rpd</i>	48700	5720	9
$\text{init} \Rightarrow \text{AF } (\text{f-in} \wedge \text{f-go})$	<i>trpd</i>	43700	2840	15
$\text{init} \Rightarrow \text{AG } (\text{f-in} \Rightarrow \text{A } (\text{f-in} \text{ Unless } (\text{f-in} \wedge \text{t-vpos-bot} \wedge \text{t-hpos-f})))$	<i>rpdc</i>	36900	2840	13
$\text{init} \Rightarrow \text{AG } ((\text{t-vpos-bot} \wedge \text{t-hpos-f} \wedge \text{t-empty}) \Rightarrow \text{A } ((\text{t-vpos-bot} \wedge \text{t-hpos-f}) \text{ Unless } (\text{f-in} \wedge \text{f-go} \wedge \text{t-vpos-bot} \wedge \text{t-hpos-f})))$	<i>rpdcu</i>	84100	3680	23
$\text{init} \Rightarrow \text{AF } (\text{t-vpos-bot} \wedge \text{t-hpos-f} \wedge \text{t-empty})$	<i>frpdcu</i>	38400	2880	13
$\text{init} \Rightarrow \text{AG } ((\text{t-vpos-bot} \wedge \text{t-hpos-f} \wedge \text{f-go} \wedge \text{f-in}) \Rightarrow \text{AF } \text{t-full})$	<i>frpdcu</i>	48700	2590	19

Table 2: Results for universal properties.

property	abstract from	without abstraction	with	red. fact.
$\text{init} \Rightarrow \text{EG } \neg \text{t-vpos-err}$	<i>frpdcu</i>	36500	2220	16
$\text{init} \Rightarrow \text{EF } \text{t-full}$	<i>rpd</i>	52500	9540	6
$\text{init} \Rightarrow \text{EF } (\text{f-in} \wedge \text{f-go})$	<i>trpd</i>	101000	3190	32
$\text{init} \Rightarrow \text{EG } (\text{f-in} \Rightarrow \text{E } (\text{f-in} \text{ Unless } (\text{f-in} \wedge \text{t-vpos-bot} \wedge \text{t-hpos-f})))$	<i>rpdc</i>	39100	4060	10
$\text{init} \Rightarrow \text{EG } ((\text{t-vpos-bot} \wedge \text{t-hpos-f} \wedge \text{t-empty}) \Rightarrow \text{E } ((\text{t-vpos-bot} \wedge \text{t-hpos-f}) \text{ Unless } (\text{f-in} \wedge \text{f-go} \wedge \text{t-vpos-bot} \wedge \text{t-hpos-f})))$	<i>rpdcu</i>	42500	3200	13
$\text{init} \Rightarrow \text{EF } (\text{t-vpos-bot} \wedge \text{t-hpos-f} \wedge \text{t-empty})$	<i>frpdcu</i>	84500	2500	34
$\text{init} \Rightarrow \text{EG } ((\text{t-vpos-bot} \wedge \text{t-hpos-f} \wedge \text{f-go} \wedge \text{f-in}) \Rightarrow \text{EF } \text{t-full})$	<i>frpdcu</i>	53600	2310	23

Table 3: Results for existential properties.

property	abstract from	without abstraction	with	red. fact.
init \Rightarrow AG ((t-vpos-bot \wedge t-hpos-f \wedge t-empty) \Rightarrow E ((t-vpos-bot \wedge t-hpos-f) Unless (f-in \wedge f-go \wedge t-vpos-bot \wedge t-hpos-f)))	<i>rpdcu</i>	42500	3160	13
init \Rightarrow EG ((t-vpos-bot \wedge t-hpos-f \wedge t-empty) \Rightarrow A ((t-vpos-bot \wedge t-hpos-f) Unless (f-in \wedge f-go \wedge t-vpos-bot \wedge t-hpos-f)))	<i>rpdcu</i>	84100	3420	25
init \Rightarrow EG ((t-vpos-bot \wedge t-hpos-f \wedge f-go \wedge f-in) \Rightarrow AF t-full)	<i>frpdcu</i>	50000	2450	20
init \Rightarrow AG ((t-vpos-bot \wedge t-hpos-f \wedge f-go \wedge f-in) \Rightarrow EF t-full)	<i>frpdcu</i>	52500	2210	24

Table 4: Results for mixed properties.

References

- [LGS⁺95] C. Loiseaux, S. Graf, J. Sifakis, A. Bouajjani, and S. Bensalem. Property preserving abstractions for the verification of concurrent systems. *Formal Methods in System Design*, Vol. 6, Iss. 1, Januari 1995.
- [BCM⁺92] J.R. Burch, E.M. Clarke, K.L. McMillan, D.L. Dill, and L.J. Hwang. Symbolic model checking: 10^{20} states and beyond. *Information and Computation*, 98(2):142–171, June 1992. Special Issue: Selections from 1990 IEEE Symposium on Logic in Computer Science.
- [Bry86] R. E. Bryant. Graph-based algorithms for boolean function manipulation. *IEEE Transactions on Computers*, 35(8):677–691, August 1986.
- [Bry92] Randal E. Bryant. Symbolic boolean manipulation with ordered binary-decision diagrams. *ACM Computing Surveys*, 24(3):293–318, September 1992.
- [CBM90] O. Coudert, C. Berthet, and J. C. Madre. Verifying temporal properties of sequential machines without building their state diagrams. In R. P. Kurshan and E. M. Clarke, editors, *Proceedings of the 1990 Workshop on Computer-Aided Verification*, June 1990.
- [CC77] P. Cousot and R. Cousot. Abstract interpretation: A unified lattice model for static analysis of programs by construction or approximation of fixpoints. In *Proceedings 4th ACM Symposium on Principles of Programming Languages (POPL)*, pages 238–252, Los Angeles, California, 1977.
- [CGL94] E. M. Clarke, O. Grumberg, and D. E. Long. Model checking and abstraction. *ACM TOPLAS*, 16(5):1512–1542, September 1994.
- [CR94] R. Cleaveland and J. Riely. A testing-based abstractions for value-passing systems. In B. Jonsson and J. Parrow, editors, *CONCUR'94: Concurrency Theory*, Lecture Notes in Computer Science 836, pages 417–432. Springer-Verlag, August 1994.

- [Dam94] M. Dam. CTL* and ECTL* as fragments of the modal μ -calculus. *Theoretical Computer Science*, 126(1):77–97, 1994.
- [DGG94] D. Dams, O. Grumberg, and R. Gerth. Abstract interpretation of reactive systems: Abstractions preserving \forall CTL*, \exists CTL* and CTL*. In E.-R. Olderog, editor, *Proceedings of the IFIP WG2.1/WG2.2/WG2.3 Working Conference on Programming Concepts, Methods and Calculi (PROCOMET)*, IFIP Transactions, Amsterdam, June 1994. North-Holland/Elsevier. Full version available as Computing Science Note 95/16, Eindhoven University of Technology, Dept. of Math. and Computing Science.
- [DHKS95] W. Damm, H. Hungar, P. Kelb, and R. Schlör. Using graphical specification languages and symbolic model checking in the verification of a production cell. In C. Lewerenz and T. Lindner, editors, *Formal Development of Reactive Systems: Case Study “Production Cell”*, volume 891 of *Lecture Notes in Computer Science*. Springer, 1995.
- [Har87] David Harel. StateCharts: A Visual Formalism for Complex Systems. *Science of Computer Programming* 8, 1987.
- [HK94] J. Helbig and P. Kelb. An OBDD-Representation of StateCharts. In *Proceedings European Design Automation Conference (EDAC)*, 1994.
- [Koz83] D. Kozen. Results on the propositional μ -calculus. *Theoretical Computer Science*, 27:333–354, 1983.
- [Tar55] A. Tarski. A Lattice-Theoretical Fixpoint Theorem and its Applications. In *Pacific Journal of Mathematics* 5, pages 285–309, 1955.

In this series appeared:

93/01	R. van Geldrop	Deriving the Aho-Corasick algorithms: a case study into the synergy of programming methods, p. 36.
93/02	T. Verhoeff	A continuous version of the Prisoner's Dilemma, p. 17
93/03	T. Verhoeff	Quicksort for linked lists, p. 8.
93/04	E.H.L. Aarts J.H.M. Korst P.J. Zwietering	Deterministic and randomized local search, p. 78.
93/05	J.C.M. Baeten C. Verhoef	A congruence theorem for structured operational semantics with predicates, p. 18.
93/06	J.P. Velkamp	On the unavailability of metastable behaviour, p. 29
93/07	P.D. Moerland	Exercises in Multiprogramming, p. 97
93/08	J. Verhoosel	A Formal Deterministic Scheduling Model for Hard Real-Time Executions in DEDOS, p. 32.
93/09	K.M. van Hee	Systems Engineering: a Formal Approach Part I: System Concepts, p. 72.
93/10	K.M. van Hee	Systems Engineering: a Formal Approach Part II: Frameworks, p. 44.
93/11	K.M. van Hee	Systems Engineering: a Formal Approach Part III: Modeling Methods, p. 101.
93/12	K.M. van Hee	Systems Engineering: a Formal Approach Part IV: Analysis Methods, p. 63.
93/13	K.M. van Hee	Systems Engineering: a Formal Approach Part V: Specification Language, p. 89.
93/14	J.C.M. Baeten J.A. Bergstra	On Sequential Composition, Action Prefixes and Process Prefix, p. 21.
93/15	J.C.M. Baeten J.A. Bergstra R.N. Bol	A Real-Time Process Logic, p. 31.
93/16	H. Schepers J. Hooman	A Trace-Based Compositional Proof Theory for Fault Tolerant Distributed Systems, p. 27
93/17	D. Alstein P. van der Stok	Hard Real-Time Reliable Multicast in the DEDOS system, p. 19.
93/18	C. Verhoef	A congruence theorem for structured operational semantics with predicates and negative premises, p. 22.
93/19	G-J. Houben	The Design of an Online Help Facility for ExSpect, p.21.
93/20	F.S. de Boer	A Process Algebra of Concurrent Constraint Programming, p. 15.
93/21	M. Codish D. Dams G. Filé M. Bruynooghe	Freeness Analysis for Logic Programs - And Correctness, p. 24
93/22	E. Poll	A Typechecker for Bijective Pure Type Systems, p. 28.
93/23	E. de Kogel	Relational Algebra and Equational Proofs, p. 23.
93/24	E. Poll and Paula Severi	Pure Type Systems with Definitions, p. 38.
93/25	H. Schepers and R. Gerth	A Compositional Proof Theory for Fault Tolerant Real-Time Distributed Systems, p. 31.
93/26	W.M.P. van der Aalst	Multi-dimensional Petri nets, p. 25.
93/27	T. Kloks and D. Kratsch	Finding all minimal separators of a graph, p. 11.
93/28	F. Kamareddine and R. Nederpelt	A Semantics for a fine λ -calculus with de Bruijn indices, p. 49.
93/29	R. Post and P. De Bra	GOLD, a Graph Oriented Language for Databases, p. 42.
93/30	J. Deogun T. Kloks D. Kratsch H. Müller	On Vertex Ranking for Permutation and Other Graphs, p. 11.

93/31	W. Körver	Derivation of delay insensitive and speed independent CMOS circuits, using directed commands and production rule sets, p. 40.
93/32	H. ten Eikelder and H. van Geldrop	On the Correctness of some Algorithms to generate Finite Automata for Regular Expressions, p. 17.
93/33	L. Loyens and J. Moonen	ILLIAS, a sequential language for parallel matrix computations, p. 20.
93/34	J.C.M. Baeten and J.A. Bergstra	Real Time Process Algebra with Infinitesimals, p.39.
93/35	W. Ferrer and P. Severi	Abstract Reduction and Topology, p. 28.
93/36	J.C.M. Baeten and J.A. Bergstra	Non Interleaving Process Algebra, p. 17.
93/37	J. Brunekreef J.P. Katoen R. Koymans S. Mauw	Design and Analysis of Dynamic Leader Election Protocols in Broadcast Networks, p. 73.
93/38	C. Verhoef	A general conservative extension theorem in process algebra, p. 17.
93/39	W.P.M. Nuijten E.H.L. Aarts D.A.A. van Erp Taalman Kip K.M. van Hee	Job Shop Scheduling by Constraint Satisfaction, p. 22.
93/40	P.D.V. van der Stok M.M.M.P.J. Claessen D. Alstein	A Hierarchical Membership Protocol for Synchronous Distributed Systems, p. 43.
93/41	A. Bijlsma	Temporal operators viewed as predicate transformers, p. 11.
93/42	P.M.P. Rambags	Automatic Verification of Regular Protocols in P/T Nets, p. 23.
93/43	B.W. Watson	A taxonomy of finite automata construction algorithms, p. 87.
93/44	B.W. Watson	A taxonomy of finite automata minimization algorithms, p. 23.
93/45	E.J. Luit J.M.M. Martin	A precise clock synchronization protocol,p.
93/46	T. Kloks D. Kratsch J. Spinrad	Treewidth and Patwidth of Cocomparability graphs of Bounded Dimension, p. 14.
93/47	W. v.d. Aalst P. De Bra G.J. Houben Y. Komatzky	Browsing Semantics in the "Tower" Model, p. 19.
93/48	R. Gerth	Verifying Sequentially Consistent Memory using Interface Refinement, p. 20.
94/01	P. America M. van der Kammen R.P. Nederpelt O.S. van Roosmalen H.C.M. de Swart	The object-oriented paradigm, p. 28.
94/02	F. Kamareddine R.P. Nederpelt	Canonical typing and Π -conversion, p. 51.
94/03	L.B. Hartman K.M. van Hee	Application of Marcov Decision Prozesse to Search Problems, p. 21.
94/04	J.C.M. Baeten J.A. Bergstra	Graph Isomorphism Models for Non Interleaving Process Algebra, p. 18.
94/05	P. Zhou J. Hooman	Formal Specification and Compositional Verification of an Atomic Broadcast Protocol, p. 22.
94/06	T. Basten T. Kunz J. Black M. Coffin D. Taylor	Time and the Order of Abstract Events in Distributed Computations, p. 29.
94/07	K.R. Apt R. Bol	Logic Programming and Negation: A Survey, p. 62.
94/08	O.S. van Roosmalen	A Hierarchical Diagrammatic Representation of Class Structure, p. 22.
94/09	J.C.M. Baeten J.A. Bergstra	Process Algebra with Partial Choice, p. 16.

94/10	T. Verhoeff	The testing Paradigm Applied to Network Structure. p. 31.
94/11	J. Peleska C. Huizing C. Petersohn	A Comparison of Ward & Mellor's Transformation Schema with State- & Activitycharts, p. 30.
94/12	T. Kloks D. Kratsch H. Müller	Dominoes, p. 14.
94/13	R. Seljée	A New Method for Integrity Constraint checking in Deductive Databases, p. 34.
94/14	W. Peremans	Ups and Downs of Type Theory, p. 9.
94/15	R.J.M. Vaessens E.H.L. Aarts J.K. Lenstra	Job Shop Scheduling by Local Search, p. 21.
94/16	R.C. Backhouse H. Doombos	Mathematical Induction Made Computational, p. 36.
94/17	S. Mauw M.A. Reniers	An Algebraic Semantics of Basic Message Sequence Charts, p. 9.
94/18	F. Kamareddine R. Nederpelt	Refining Reduction in the Lambda Calculus, p. 15.
94/19	B.W. Watson	The performance of single-keyword and multiple-keyword pattern matching algorithms, p. 46.
94/20	R. Bloo F. Kamareddine R. Nederpelt	Beyond β -Reduction in Church's $\lambda \rightarrow$, p. 22.
94/21	B.W. Watson	An introduction to the Fire engine: A C++ toolkit for Finite automata and Regular Expressions.
94/22	B.W. Watson	The design and implementation of the FIRE engine: A C++ toolkit for Finite automata and regular Expressions.
94/23	S. Mauw and M.A. Reniers	An algebraic semantics of Message Sequence Charts, p. 43.
94/24	D. Dams O. Grumberg R. Gerth	Abstract Interpretation of Reactive Systems: Abstractions Preserving \forall CTL*, \exists CTL* and CTL*, p. 28.
94/25	T. Kloks	$K_{1,3}$ -free and W_4 -free graphs, p. 10.
94/26	R.R. Hoogerwoord	On the foundations of functional programming: a programmer's point of view, p. 54.
94/27	S. Mauw and H. Mulder	Regularity of BPA-Systems is Decidable, p. 14.
94/28	C.W.A.M. van Overveld M. Verhoeven	Stars or Stripes: a comparative study of finite and transfinite techniques for surface modelling, p. 20.
94/29	J. Hooman	Correctness of Real Time Systems by Construction, p. 22.
94/30	J.C.M. Baeten J.A. Bergstra Gh. Ştefănescu	Process Algebra with Feedback, p. 22.
94/31	B.W. Watson R.E. Watson	A Boyer-Moore type algorithm for regular expression pattern matching, p. 22.
94/32	J.J. Vereijken	Fischer's Protocol in Timed Process Algebra, p. 38.
94/33	T. Laan	A formalization of the Ramified Type Theory, p.40.
94/34	R. Bloo F. Kamareddine R. Nederpelt	The Barendregt Cube with Definitions and Generalised Reduction, p. 37.
94/35	J.C.M. Baeten S. Mauw	Delayed choice: an operator for joining Message Sequence Charts, p. 15.
94/36	F. Kamareddine R. Nederpelt	Canonical typing and Π -conversion in the Barendregt Cube, p. 19.
94/37	T. Basten R. Bol M. Voorhoeve	Simulating and Analyzing Railway Interlockings in ExSpect, p. 30.
94/38	A. Bijlsma C.S. Scholten	Point-free substitution, p. 10.

94/39	A. Blokhuis T. Kloks	On the equivalence covering number of splitgraphs, p. 4.	
94/40	D. Alstein	Distributed Consensus and Hard Real-Time Systems, p. 34.	
94/41	T. Kloks D. Kratsch	Computing a perfect edge without vertex elimination ordering of a chordal bipartite graph, p. 6.	
94/42	J. Engelfriet J.J. Vereijken	Concatenation of Graphs, p. 7.	
94/43	R.C. Backhouse M. Bijsterveld	Category Theory as Coherently Constructive Lattice Theory: An Illustration, p. 35.	
94/44	E. Brinksma R. Gerth W. Janssen S. Katz M. Poel C. Rump	J. Davies S. Graf B. Jonsson G. Lowe A. Pnueli I. Zwiars	Verifying Sequentially Consistent Memory, p. 160
94/45	G.J. Houben	Tutorial voor de ExSpec-bibliotheek voor "Administratieve Logistiek", p. 43.	
94/46	R. Bloo F. Kamareddine R. Nederpelt	The λ -cube with classes of terms modulo conversion, p. 16.	
94/47	R. Bloo F. Kamareddine R. Nederpelt	On Π -conversion in Type Theory, p. 12.	
94/48	Mathematics of Program Construction Group	Fixed-Point Calculus, p. 11.	
94/49	J.C.M. Baeten J.A. Bergstra	Process Algebra with Propositional Signals, p. 25.	
94/50	H. Geuvers	A short and flexible proof of Strong Normalization for the Calculus of Constructions, p. 27.	
94/51	T. Kloks D. Kratsch H. Müller	Listing simplicial vertices and recognizing diamond-free graphs, p. 4.	
94/52	W. Penczek R. Kuiper	Traces and Logic, p. 81	
94/53	R. Gerth R. Kuiper D. Peled W. Penczek	A Partial Order Approach to Branching Time Logic Model Checking, p. 20.	
95/01	J.J. Lukkien	The Construction of a small CommunicationLibrary, p.16.	
95/02	M. Bezem R. Bol J.F. Groote	Formalizing Process Algebraic Verifications in the Calculus of Constructions, p.49.	
95/03	J.C.M. Baeten C. Verhoef	Concrete process algebra, p. 134.	
95/04	J. Hidders	An Isotopic Invariant for Planar Drawings of Connected Planar Graphs, p. 9.	
95/05	P. Severi	A Type Inference Algorithm for Pure Type Systems, p.20.	
95/06	T.W.M. Vossen M.G.A. Verhoeven H.M.M. ten Eikelder E.H.L. Aarts	A Quantitative Analysis of Iterated Local Search, p.23.	
95/07	G.A.M. de Bruyn O.S. van Roosmalen	Drawing Execution Graphs by Parsing, p. 10.	
95/08	R. Bloo	Preservation of Strong Normalisation for Explicit Substitution, p. 12.	
95/09	J.C.M. Baeten J.A. Bergstra	Discrete Time Process Algebra, p. 20	
95/10	R.C. Backhouse R. Verhoeven O. Weber	Math _{pad} : A System for On-Line Preparation of Mathematical Documents, p. 15	

95/11	R. Seljée	Deductive Database Systems and integrity constraint checking, p. 36.
95/12	S. Mauw and M. Reniers	Empty Interworkings and Refinement Semantics of Interworkings Revised, p. 19.
95/13	B.W. Watson and G. Zwaan	A taxonomy of sublinear multiple keyword pattern matching algorithms, p. 26.
95/14	A. Ponse, C. Verhoef, S.F.M. Vlijmen (eds.)	De proceedings: ACP'95, p.
95/15	P. Niebert and W. Penczek	On the Connection of Partial Order Logics and Partial Order Reduction Methods, p. 12.
95/16	D. Dams, O. Grumberg, R. Gerth	Abstract Interpretation of Reactive Systems: Preservation of CTL*, p. 27.
95/17	S. Mauw and E.A. van der Meulen	Specification of tools for Message Sequence Charts, p. 36.
95/18	F. Kamareddine and T. Laan	A Reflection on Russell's Ramified Types and Kripke's Hierarchy of Truths, p. 14.
95/19	J.C.M. Baeten and J.A. Bergstra	Discrete Time Process Algebra with Abstraction, p. 15.
95/20	F. van Raamsdonk and P. Severi	On Normalisation, p. 33.
95/21	A. van Deursen	Axiomatizing Early and Late Input by Variable Elimination, p. 44.
95/22	B. Arnold, A. v. Deursen, M. Res	An Algebraic Specification of a Language for Describing Financial Products, p. 11.
95/23	W.M.P. van der Aalst	Petri net based scheduling, p. 20.
95/24	F.P.M. Dignum, W.P.M. Nuijten, L.M.A. Janssen	Solving a Time Tabling Problem by Constraint Satisfaction, p. 14.
95/25	L. Feijs	Synchronous Sequence Charts In Action, p. 36.
95/26	W.M.P. van der Aalst	A Class of Petri nets for modeling and analyzing business processes, p. 24.
95/27	P.D.V. van der Stok, J. van der Wal	Proceedings of the Real-Time Database Workshop, p. 106.
95/28	W. Fokkink, C. Verhoef	A Conservative Look at term Deduction Systems with Variable Binding, p. 29.
95/29	H. Jurjus	On Nesting of a Nonmonotonic Conditional, p. 14
95/30	J. Hidders, C. Hoskens, J. Paredaens	The Formal Model of a Pattern Browsing Technique, p.24.