

Mach numbers for gases and plasmas in a convergent-divergent cascaded arc

Citation for published version (APA):

Burm, K. T. A. L., Goedheer, W. J., & Schram, D. C. (1999). Mach numbers for gases and plasmas in a convergent-divergent cascaded arc. *Physics of Plasmas*, 6(6), 2628-2635. <https://doi.org/10.1063/1.873536>

DOI:

[10.1063/1.873536](https://doi.org/10.1063/1.873536)

Document status and date:

Published: 01/01/1999

Document Version:

Publisher's PDF, also known as Version of Record (includes final page, issue and volume numbers)

Please check the document version of this publication:

- A submitted manuscript is the version of the article upon submission and before peer-review. There can be important differences between the submitted version and the official published version of record. People interested in the research are advised to contact the author for the final version of the publication, or visit the DOI to the publisher's website.
- The final author version and the galley proof are versions of the publication after peer review.
- The final published version features the final layout of the paper including the volume, issue and page numbers.

[Link to publication](#)

General rights

Copyright and moral rights for the publications made accessible in the public portal are retained by the authors and/or other copyright owners and it is a condition of accessing publications that users recognise and abide by the legal requirements associated with these rights.

- Users may download and print one copy of any publication from the public portal for the purpose of private study or research.
- You may not further distribute the material or use it for any profit-making activity or commercial gain
- You may freely distribute the URL identifying the publication in the public portal.

If the publication is distributed under the terms of Article 25fa of the Dutch Copyright Act, indicated by the "Taverne" license above, please follow below link for the End User Agreement:

www.tue.nl/taverne

Take down policy

If you believe that this document breaches copyright please contact us at:

openaccess@tue.nl

providing details and we will investigate your claim.

Mach numbers for gases and plasmas in a convergent-divergent cascaded arc

K. T. A. L. Burm

Department of Applied Physics, Eindhoven University of Technology, P.O. Box 513, 5600 MB Eindhoven, The Netherlands

W. J. Goedheer

F.O.M. Institute for Plasma Physics "Rijnhuizen," partner to the trilateral Euregio Cluster, P.O. Box 1207, 3430 BE Nieuwegein, The Netherlands

D. C. Schram

Department of Applied Physics, Eindhoven University of Technology, P.O. Box 513, 5600 MB Eindhoven, The Netherlands

(Received 22 December 1998; accepted 1 March 1999)

For a plasma, flowing through a cascaded arc channel with a varying cross-section, and flowing from a subsonic to a supersonic state, the sonic condition moves downstream and the plasma Mach number at the smallest cross section is less than one, although in case of a transonic isentropic gas flow the sonic condition is found at the smallest cross section. This shift in sonic condition is due to the lack of isentropic behavior of the plasma flow. Sources causing the anisentropy are viscosity, heat and ionization, of which ionization is vital for a plasma. It is found that the plasma Mach number is always lower than the corresponding gas Mach number. A quasi one-dimensional analysis and simulations with a two-dimensional plasma model, which support the analysis, are presented.

© 1999 American Institute of Physics. [S1070-664X(99)01906-0]

I. INTRODUCTION

The study of the cascaded arc plasma source¹⁻⁴ is of interest for remote deposition⁵ and etching.⁶ Cascaded arcs are used as particle sources in such plasma process systems. The arc creates wall stabilized flowing thermal plasmas.

For fast deposition a high ion flux is preferable. The cascaded arc has proven to be an efficient ion source.^{4,7-9} Ionization degrees over 50% can be reached when the arc channel is geometrically pinched (i.e., has a convergent-divergent geometry).⁷ Besides an increase in the ionization efficiency, an increase in the arc exit velocity increases the ion flux coming out of the arc. To optimize the cascaded arc as an ion source, besides ion production efficiency, knowledge of the flow behavior (i.e., Mach numbers) and the transonic position (i.e., where the Mach number equals one) are therefore, of interest. In this paper we will focus on the Mach numbers inside the arc channel to describe the flow behavior. For a discussion of the arc efficiency we refer to Burm *et al.*⁷

Compressible fluid flow through channels of which the cross section varies will be considered. It is assumed that the flow can be adequately modeled by a quasi one-dimensional flow model. The flow is assumed to be one-dimensional at all cross sections of the channel. Therefore, the rate of change in cross-sectional area with distance along the channel may not be very large.

We will show that the effects of area changes on a plasma flow differ from those on an isentropic gas flow. A plasma is never isentropic due to inelastic collisions which can ionize the plasma, due to viscosity and due to Ohmic heating of the plasma. We will show that the isentropic gas case is a special case, and that, in a convergent-divergent

channel, ionization, viscosity, and heating shift the sonic condition from the throat towards the arc outlet. Plasma Mach numbers are shown to be lower than gas Mach numbers.

Simulations with a two-dimensional model supporting the results of the quasi one-dimensional model will be presented.

II. THE CASCADED ARC

The flow channel considered is a cylinder symmetric cascaded arc configuration as shown in Fig. 1. The arc¹⁻⁴ consists of three cathodes at the cathode housing and a stack of electrically isolated copper plates, forming the arc channel together with the anode at the arc outlet. The gas inlet flow, which is injected between the three cathode tips, is controlled by a mass flow controller. The plasma expands supersonically into a vacuum chamber located at the arc outlet (not shown in Fig. 1).

The arc depicted in Fig. 1 has a convergent-divergent channel, but a cascaded arc with a straight plasma channel has also been used. The cascaded arcs used typically have a channel length of 34 mm and an outlet diameter of 4 mm.

III. THE PLASMA MACH NUMBER

We will consider the influence of a changing flow cross-sectional area, the influence of shear stress at the wall, as well as the influence of heat exchange on the Mach number in the cascaded arc channel. The Mach number, M , is defined¹⁰⁻¹⁶ as the ratio of the local velocity, w , and the local speed of sound, c

$$M = \frac{w}{c}. \quad (1)$$

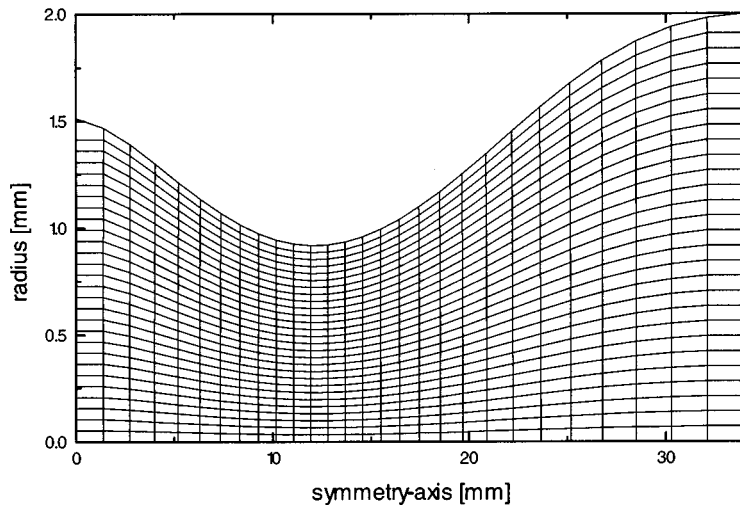
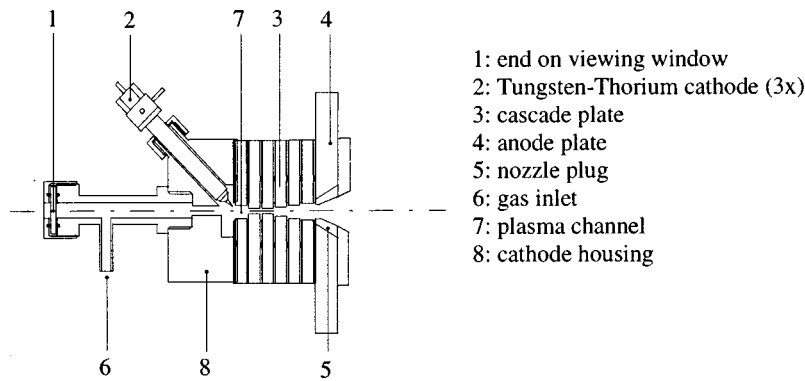

FIG. 1. The cascaded arc (top), and the grid and channel geometry as used in the simulations (bottom).

The speed of sound depends on the type of fluid under consideration, and is defined as

$$c^2 = \left(\frac{\partial p}{\partial \rho} \right)_s, \tag{2}$$

where p is the pressure, ρ the mass density, and s the entropy. In case of an isentropic gas

$$\frac{p}{\rho^\gamma} = C \tag{2a}$$

and

$$p = \rho RT, \tag{3a}$$

which means that

$$c = \sqrt{\gamma RT}, \tag{4a}$$

where γ the isentropic exponent for a specific gas, C is a constant, T is the gas temperature, and R the mass specific gas constant.

In case of a plasma, the isentropic exponent in Expression (2a) and the temperature in Expression (3a) are different. The isentropic exponent, which equals the ratio of the heat capacities at constant pressure, c_p , and at constant volume, c_v , is lower in a plasma than in a gas.¹⁰ A plasma is never isentropic, which is due to inelastic collisions that ion-

ize the plasma, due to viscosity, and due to Ohmic heating of the plasma. This nonisentropic behavior requires a more accurate specification of the plasma temperature and the isentropic exponent.

Considering its thermodynamics, we found that due to ionization, the isentropic exponent for a two-temperature argon plasma of around 1.2–1.3 eV equals 1.2 for almost the whole ionization range (5%–80%). An analysis of how γ depends on the ionization degree and temperature can be found in Ref. 10. It should be noted that to create a plasma, heat is supplied to ionize. A chemical energy term (ionization) appears in the specific enthalpy and in the internal energy expressions, which term is quite dominant in both cases. Consequently, both heat capacities c_p and c_v increase such that the ratio c_p/c_v becomes smaller.

From these results we get, in the case of a plasma,

$$\frac{p}{\rho^{\gamma_p}} = C_p \tag{2b}$$

and

$$p = \rho R(T_h + \alpha T_e) \tag{3b}$$

which means that

$$c = \sqrt{\gamma_p R(T_h + \alpha T_e)}, \tag{4b}$$

in which γ_p is the isentropic exponent for a plasma, C_p is a constant, and the plasma temperature is defined as the weighted sum of the heavy particle (i.e., atoms and ions) temperature, T_h , and the electron temperature, T_e , in which the ionization degree α is defined as

$$\alpha = \frac{n_i}{n_i + n_a}, \quad (5)$$

where n_i is the ion number density and n_a is the atom number density.

The isentropic exponent is lower and the temperature is defined differently (i.e., more generally) for a plasma than for a gas, which leads to a change of the definition of the velocity of sound. Again, this important difference between a plasma and a gas is due to ionization.

The local plasma Mach number, Expression (1), becomes

$$M = \frac{\varphi}{\rho A \sqrt{\gamma_p R(T_h + \alpha T_e)}} = \frac{\varphi}{\rho A} \sqrt{\frac{R(T_h + \alpha T_e)}{\gamma_p}}, \quad (6)$$

making use of the inlet mass flow φ , equal to $\rho w A$, with A the cross-sectional area πr^2 . According to Expression (6), the plasma Mach number in a subsonic plasma flow can be increased (*ceteris paribus*) 1) by increasing the inlet flow, 2) by decreasing the plasma temperature, 3) by decreasing the ionization degree, α , 4) by decreasing the isentropic exponent, γ , 5) by decreasing the arc channel cross-section, A , and 6) by increasing mass (via R).

IV. RESULTS FROM THE QUASI ONE-DIMENSIONAL MODEL

Let us next consider the flow behavior of a fluid flowing through the cascaded arc while taking into account that the Mach number is fluid dependent. The flow behavior can be found by solving the equations for conservation of mass, momentum, and energy.

Mass conservation in differential form gives

$$\frac{dw}{w} + \frac{dp}{\rho} + \frac{dA}{A} = 0. \quad (7)$$

Since the wall shear stress force is equal to the shear stress, τ_w , times the surface area $S \cos \vartheta$, where S is the wall surface and ϑ the wall inclination angle, the momentum balance for a small control volume reads

$$\begin{aligned} pA + (p + dp/2)dA - \tau_w S \cos \vartheta \\ = (p + dp)(A + dA) + \rho w A dw, \end{aligned} \quad (8)$$

since the average pressure on the curved wall surface, which has a projected area of dA , is $(p + dp/2)$. The term $A \rho w dw$ is deduced from the increase in velocity over the control volume $\rho w A[(w + dw) - w]$. This yields in first order

$$\rho w dw + dp = -\tau_w \frac{2}{r} dz = -\frac{\rho w^2}{2} f \frac{2}{r} dz, \quad (9)$$

where z is the symmetry axis, and f the dimensionless Fanning friction factor.^{2,11-14} The Fanning friction factor is a function of the Reynolds number, Re

$$Re = \frac{2\rho w r}{\mu}, \quad (10)$$

where μ is the dynamic viscosity. For laminar gas flows (i.e., $Re < 2300$) the dimensionless Fanning friction factor is equal to^{2,11-14}

$$f = \frac{2\tau_w}{\rho w^2} = \frac{16}{Re}, \quad (11)$$

and is valid for any wall roughness, as the heat loss in laminar flow is independent of wall roughness.¹⁵

According to Expressions (10) and (11) the geometry of the arc channel, density gradients, and temperature gradients (because μ is a function of the temperature) influence the friction factor. The quasi one-dimensional model assumption that the flow is one-dimensional at all cross sections of the channel, however, denies the fact that radial gradients may influence the friction factor. We will discuss radial profiles in Sec. V B.

Note further that, in case of a plasma, the Fanning friction factor, f , is also partly determined by the ions inside the plasma.

Conservation of energy yields

$$c_p dT + w dw = dQ, \quad (12)$$

where dQ is the rate of heating, and T the (gas mixture or plasma) temperature. Heating (cooling) can occur by, e.g., Ohmic heating, from heating (cooling) the flow channels, and by chemical reactions in the plasma. All three types of heating occur in the cascaded arc plasma source.^{1-4,6-9}

Equations (7), (9), and (12) are ‘‘global’’ equations in the sense that they do not consider the particle types in the fluid individually. The expressions take the total fluid (mixture) into account integrated over the cross section, and no radial dependencies are assumed.

Using Mach’s number, M , together with the equation of state in derivative form, and using the isentropic temperature expression, we derived from the expressions of mass, momentum, and energy conservation, that¹¹

$$\begin{aligned} (1 - M^2) \frac{dM}{M} = \left(1 + \frac{\gamma - 1}{2} M^2\right) \left(\gamma M^2 \frac{f}{r} dz - \frac{dA}{A}\right) \\ + \left(\frac{1 + \gamma M^2}{2}\right) \frac{dQ}{c_p T}. \end{aligned} \quad (13)$$

This equation shows the flow behavior of the considered fluid. At the sonic point, i.e., at the position where the Mach number equals one, Equation (13) reads

$$\frac{dA}{A} = \frac{f}{r} dz + \frac{dQ}{c_p T}. \quad (14)$$

Hence, the cross-sectional area must increase as long as the Mach number has to stay constant and equal to one.

Equation (13) shows two sources, viscosity and heat exchange, which shift the sonic position downstream from the minimum of the cross-sectional area (i.e., at $dA = 0$) for a transonic flow in a convergent-divergent nozzle. If the flow is not transonic, the flow remains subsonic or supersonic,

and, according to Eq. (13), the optimum in the Mach number will *not* be at the minimum of the cross-sectional area due to the already mentioned friction and heating.

A third source that shifts the sonic position are the plasma temperature T and the thermodynamic properties of the fluid, expressed by the isentropic exponent γ and the specific heat c_p in Eqs. (13) and (14). Remember that ionization (essentially important for plasmas) influences the plasma temperature and the thermodynamic properties c_v , c_p and γ , and therefore, shifts the sonic position indirectly.

A. Special cases: The isentropic gas case

In an isentropic gas there is no heat addition and the influence of viscosity is neglected.^{11-14,16,17} In the Eqs. (9) and (12), f and dQ equal zero. The equation for the flow behavior (13) becomes

$$\frac{dA}{A} = \frac{M^2 - 1}{1 + (\gamma - 1)/2M^2} \frac{dM}{M}. \tag{15}$$

From this equation it follows that when the isentropic gas flow is subsonic ($M < 1$) dM is positive (since $\gamma > 1$) in the convergent part of the channel, i.e., as dA is negative. When the flow is supersonic ($M > 1$) dM is negative in the convergent part of the channel. At the minimum cross-section ($dA = 0$), the sonic condition ($M = 1$), or an optimum in the Mach number ($dM = 0$) will be found.

These results show the well-known behavior that if a subsonic isentropic flow is to be accelerated to a supersonic flow we may use a convergent-divergent nozzle. The convergent part accelerates the flow up to a Mach number equal to one, and the divergent part then accelerates the flow to supersonic speed. At the throat ($dA = 0$) the Mach number must be equal to one.

In such a nozzle the pressure will fall continuously. If the pressure at the end is not low enough, the flow will remain subsonic throughout. In this latter situation, the Mach number and the velocity reach their maximum at the throat.

Similarly, two possibilities exist for a supersonic isentropic flow. Either the Mach number will decrease to $M = 1$ at the throat and then continue to decrease to subsonic velocity in the divergent part of the nozzle, or the flow remains supersonic throughout the nozzle. In this latter case, the Mach number and the velocity reach their minimum at the throat, although these values are still supersonic.

B. Special cases: The static Fanno flow

In the discussion of an isentropic gas flow through a convergent-divergent nozzle, given in Sec. IV A, the effect of viscosity, heating, and ionization have been neglected. This is often an adequate assumption for gas flows through straight nozzles, although for small and long nozzles the effects of viscosity, i.e., the effects of fluid friction at the walls, can be important.

We will discuss here the influence of friction on the Mach number in a straight nozzle. A straight channel reduces complexity and draws our attention to how viscosity influences the Mach number. A compressible adiabatic flow in a constant cross-sectional area channel including frictional ef-

fects is called a Fanno flow.^{11,12} Note that in compressible fluids friction changes all of the flow variables, because changes in pressure causes changes in density which leads to changes in velocity. Combining the conservation equations of mass, momentum and energy with the equation of state as in Sec. IV, while setting $dA = 0$ and $dQ = 0$, yields

$$(1 - M^2) \frac{dM}{M} = \gamma M^2 \left(1 + \frac{\gamma - 1}{2} M^2 \right) \frac{\tau_w}{\rho w^2} \frac{2}{r} dz. \tag{16}$$

Note that from Eq. (16) it follows that the sign of dM is prescribed by the sign of $(1 - M^2)$, because, since $\gamma > 1$, the right hand side is always positive. This equation shows that for subsonic flow ($M < 1$), wall shear stress causes the Mach number to rise, and for supersonic flow ($M > 1$) wall friction causes the Mach number to fall. Therefore, viscosity causes the Mach number to tend towards one.

Once the Mach number of one is attained in case of transonic flows, upstream conditions cannot be affected by downstream conditions any longer. Therefore, so-called choking can occur as a result of wall shear stress. The mass flow rate is now limited due to wall friction. The Mach number of one is attained at the channel exit.^{11-14,16-18}

In a similar way as in Eq. (16) the next equations show how viscosity influences the other flow variables.

$$\frac{dp}{p} = - \frac{\gamma M^2 [1 + (\gamma - 1)M^2]}{1 - M^2} \frac{\tau_w}{\rho w^2} \frac{2}{r} dz, \tag{17}$$

$$\frac{dT}{T} = - \frac{\gamma(\gamma - 1)M^4}{1 - M^2} \frac{\tau_w}{\rho w^2} \frac{2}{r} dz, \tag{18}$$

$$ds = (\gamma - 1)M^2 \frac{\tau_w}{\rho w^2} \frac{2}{r} dz, \tag{19}$$

where ds is the enthalpy change. Note that $ds > 0$ since $\gamma > 1$, and that dp and dT are negative for subsonic flows ($M < 1$) and positive for supersonic flows ($M > 1$).

C. Special cases: Balancing viscosity effects with cooling

In a plasma flowing through the cascaded arc, Ohmic heating heats the plasma mainly near the arc inlet. This heat is transported by the plasma and lost by cooling at the wall and at the arc channel outlet.^{1-4,7,19} Cooling at the walls can be influenced by changing the wall temperature, which in fact changes the temperature gradient near the wall and, therefore, changes the heat conduction towards the wall. Note that by choosing the cooling at the wall ($-dQ$) equal to

$$-dQ = \gamma \frac{f}{r} c_p T dz, \tag{20}$$

the sonic position is again located at the minimum of the cross-sectional area of the convergent-divergent nozzle (i.e., at $dA = 0$). We find that the sonic condition occurs at the throat of the arc channel as in the case of the transonic isentropic gas flow.

Note that if the flow is not transonic the optimum in the Mach number is shifted back upstream towards the

Influence of viscosity (Argon case)

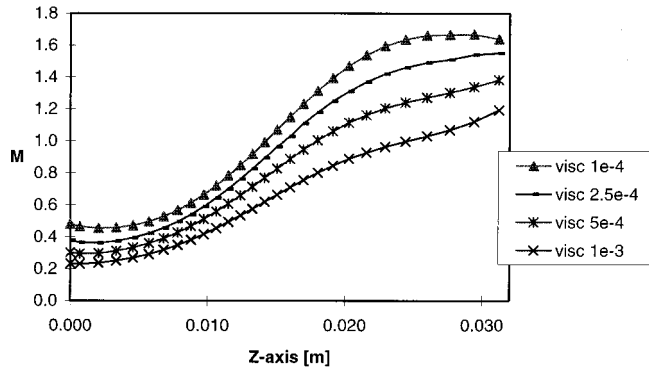

FIG. 2. An increase in viscosity [μ (m^2/s) increases] lowers the Mach number inside the argon gas nozzle.

minimum of the cross-sectional area of the convergent-divergent nozzle according to an expression similar to Expression (20).

V. SIMULATIONS USING THE PLASMA SIMULATION MODEL PLASIMO

From the previous discussion it can be concluded that Mach numbers in a convergent-divergent plasma differ from Mach numbers in a perfect isentropic gas due to the nonisentropic effects, i.e., viscosity and heat sources, and due to the occurrence of ionization. To verify this statement, we will model gases and plasmas flowing through a convergent-divergent cascaded arc plasma source with a two-dimensional model called PLASIMO.¹⁹ The PLASIMO simulation model uses the control volume concept with conservation of fluxes to make the transport equations discrete. In the quasi one-dimensional model, as used in previous sections, the volumes cover the whole cross section. We will compare the quasi one-dimensional plasma flow model with the results of the two-dimensional PLASIMO model. PLASIMO can indicate how well the quasi one-dimensional assumption is, a subject which we will discuss in Sec. V B.

The simulation program PLASIMO is a hydrodynamic numerical model with which bulk flow variables, such as velocity, pressure, densities, and temperatures, can be calculated. PLASIMO is used to study stationary cylinder symmetric plasmas. For a full discussion of the PLASIMO model see Janssen *et al.*¹⁹

A. PLASIMO simulation results

To study the values of the Mach number inside the cascaded arc channel three different fluids were considered: A mono-atomic gas (argon), a molecular gas (hydrogen), and a mono-atomic plasma (argon).

A gas flow is prescribed at the arc inlet. The imposed fluxes are varied but inflow occurs always at low velocities. The gas inlet flow is subsonic. A plasma can be created inside the arc channel via ionization by Ohmic heating. To simulate the gas flows through the arc, the Ohmic energy input is set equal to zero. At the arc outlet the gas or plasma

Influence of viscosity (Hydrogen case)

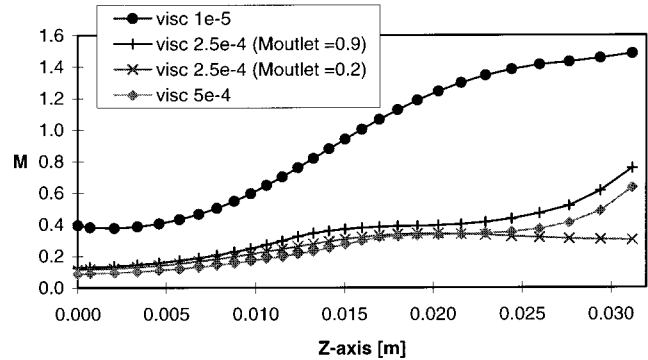

FIG. 3. An increase in viscosity [μ (m^2/s) increases] lowers the Mach number inside the hydrogen gas nozzle.

expands into a ‘‘low pressure vessel’’ where a shock occurs (background pressure ± 50 Pa). Our case is that of an under expanded fluid.¹¹ The Mach numbers in the pre-expansion (the expansion before the shock) must be larger than one. Therefore, the fluid must pass the sonic condition. As shown before, isentropic gas theory pinpoints the location at which the sonic condition occurs at the smallest cross section (i.e., the channel outlet in case of straight channels). As discussed, plasmas never fulfil the isentropic condition.

We will show that the sonic condition will move downstream in the two-dimensional flow case conform the quasi one-dimensional model results, when viscosity and heating (i.e., anisotropy), and more specific ionization and the creation of a plasma, are introduced. In the next figures, obtained with PLASIMO, we will show the decrease of the Mach number along the symmetry axis (z axis) due to an increase in the dynamic viscosity coefficient, μ , and due to an increase in heat addition by increasing the wall temperature, T_{wall} , for the cases of an argon gas and a hydrogen gas, respectively. We will find differences in flow behavior when comparing the Ar gas case with the H_2 gas case. Afterwards, the influence of ionization will be discussed for straight arc flows when we compare Mach number values in an argon plasma with an argon gas. For an argon plasma we will show the influence on the Mach number of a decrease in the smallest cross section, A .

In Figs. 2 and 3 the influence of viscosity on the Mach number inside the channel is shown for argon and hydrogen

Sonic position as function of viscosity

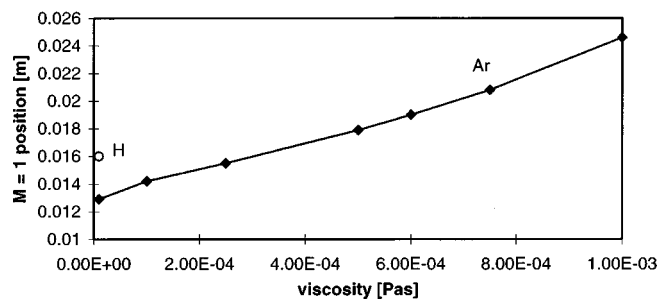

FIG. 4. The influence of viscosity on the sonic position.

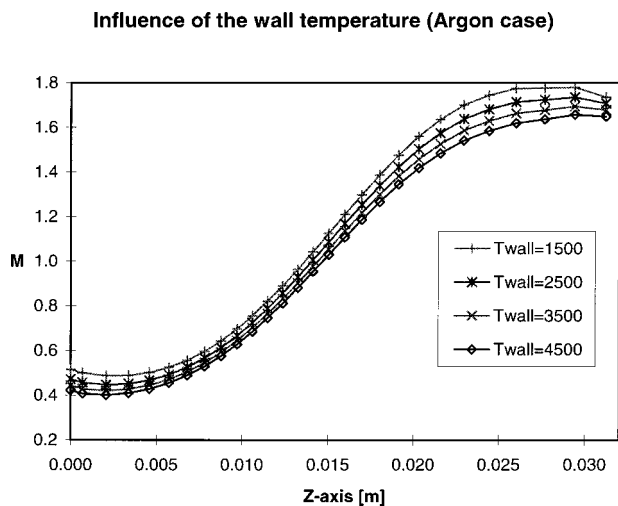

FIG. 5. An increase in the wall temperature [T_{wall} (K) increases] lowers the Mach number inside the argon gas nozzle.

gases. To get these results, the viscosity coefficient, μ , has been changed to a certain value inside the PLASIMO program (flow 100 scc/s, no current). As is shown in both figures, an increase in the viscosity (coefficient) decreases the Mach number at every position inside the arc. Therefore, the position where the Mach number equals one, or where the Mach number reaches its maximum moves downstream.

The transonic flows in Figs. 2 and 3 are a result of the low background pressure in the vacuum vessel in which the flow expands. However, because PLASIMO¹⁹ requires a specification of the outflow Mach number, we modeled transonic flows by use of the condition that the Mach number is larger than one at the outlet. The precise outlet Mach number depends on the arc configuration and ranges from $M=1$ until $M=2$. However, we did not have to state the outlet Mach condition very accurately, since for supersonic outlet flows the outlet Mach number does not influence the upstream flow.^{7,19}

For subsonic flows an outlet Mach number of 0.9 has been used at first, as in case of straight arcs.¹⁹ Unfortunately, the outlet Mach number had to be chosen more precisely for subsonic flows, as demonstrated by taking the outlet Mach

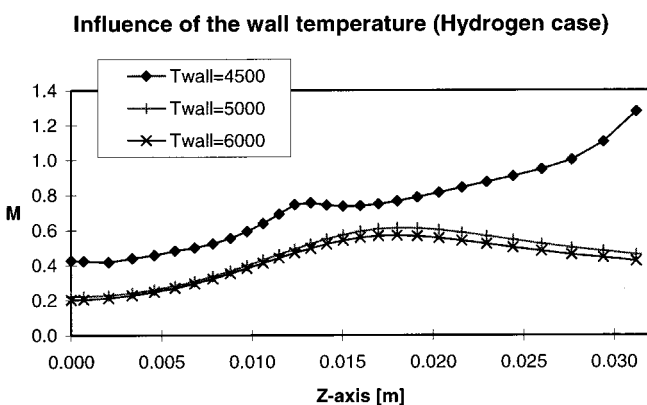

FIG. 6. An increase in the wall temperature [T_{wall} (K) increases] lowers the Mach number inside the hydrogen gas nozzle.

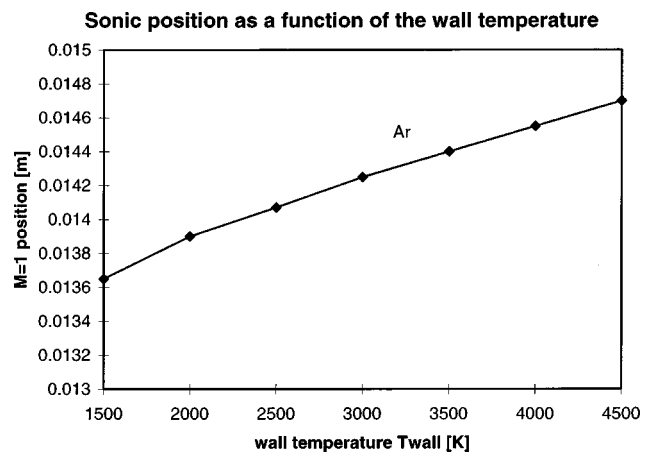

FIG. 7. The influence of the wall temperature T_{wall} on the sonic position.

number equal to 0.2 in Fig. 3. Note that the optimum in the Mach number is slightly influenced by the chosen outlet Mach number.

Figure 4 shows that the sonic position depends almost linearly on the viscosity coefficient and is gas dependent (via its mass, the isentropic coefficient γ and the friction factor f), as reflected by Expressions (10), (11), and (14).

In Figs. 5 and 6 we show the influence of the wall temperature on the Mach number inside the cascaded arc (flow 100 scc/s, no current). The chosen wall temperatures are an input of the PLASIMO program. Both figures show a decrease in the Mach number at every position inside the arc as function of the wall temperature. Therefore, the transonic position must move downstream.

In case of hydrogen, the flows we simulate remain subsonic. For the subsonic flows we find a maximum Mach number instead of a sonic transition. This maximum moves downstream, like the sonic position in transonic flows, when the wall temperature increases, i.e., when less heat is transported towards the arc wall (see Sec. IV C). Therefore, an increase in wall temperature moves the sonic position or the Mach number optimum downstream.

According to Fig. 7 the sonic position is a degressive increasing function of the amount of ‘‘heating’’ (increase in wall temperature), as already indicated by Expression (14).

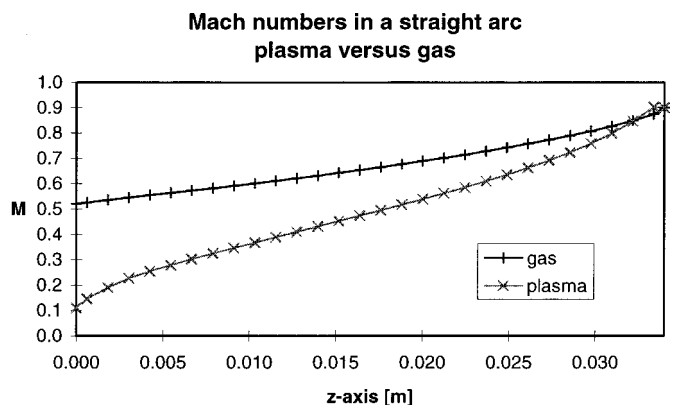

FIG. 8. A comparison of plasma flow Mach numbers with gas flow Mach numbers.

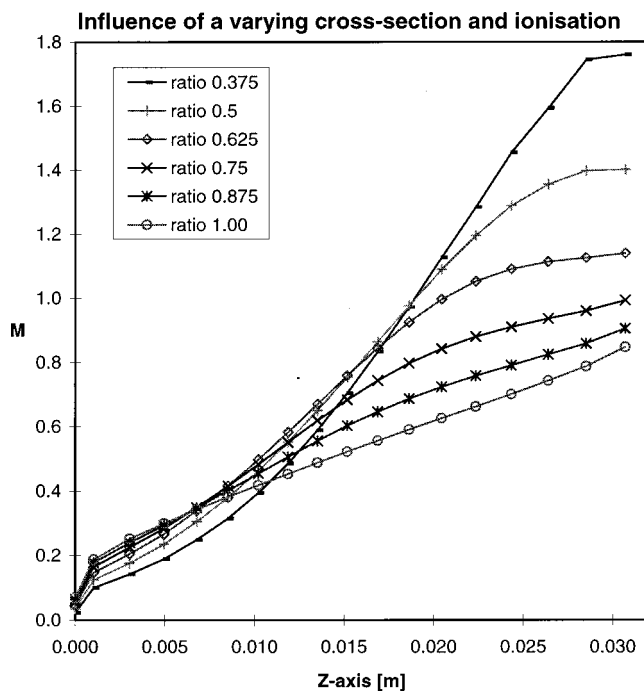

FIG. 9. Increasing the smallest cross section lowers the Mach number inside the arc nozzle.

In Figs. 2–7 Mach numbers for gases were considered. Next we will discuss the Mach number for *plasma* flows. For the creation of plasmas, ionization is essential. As noted before, ionization influences the plasma temperature and the thermodynamic properties of the plasma. The differences in Mach numbers between gases and plasmas are mainly due to ionization. In Fig. 8 Mach numbers for an argon plasma (flow 100 scc/s, current 50 A) flowing through a straight channel are compared with Mach numbers for an argon gas flow (flow 100 scc/s, no current). Relatively large differences in Mach number values can be found near the arc inlet, where ionization is most effective.⁷

In Fig. 9 an argon plasma flow (flow 100 scc/s, current 50 A) is used to show the influence of a change in cross section on the Mach number. The ratio indicates the ratio of the smallest diameter divided by the outlet diameter. Figure 9 shows that the flows through the 0.375, 0.5, and 0.625 arcs are transonic. When the diameter ratio is smaller, the derivative of the wall shape is already large closer to the smallest cross section. Therefore, the sonic position moves upstream.

Arcs with small diameter ratios produce higher ionization degrees than arcs with ratios close to one, as ionization occurs mainly near the arc inlet.⁷ Figures 8 and 9 indicate that high ionization degrees near the arc inlet lowers the Mach number there. This is in agreement with the general idea that ionization is an extra degree of freedom influencing the plasma temperature, the heat capacity c_p , and the heat capacity ratio γ . The Mach number and the sonic position are a function of c_p and γ according to Expressions (13) and (14).

B. Form factors

So far we have analyzed the Mach number in the cascaded arc with a quasi one-dimensional model and simulated

the Mach number with a two-dimensional plasma simulation model named PLASIMO. The results from the two-dimensional plasma simulation model confirm the quasi one-dimensional analysis, although the two models differ theoretically with respect to form factors (or radial profiles). While PLASIMO allows for all type of profiles to exist (e.g., concave, convex, and flat), the quasi one-dimensional model allows for only flat profiles.

To investigate the difference in approach, we examined the profiles as reported by PLASIMO. We find a flat radial profile for the pressure, slightly convex radial profiles for the velocity, the electron and heavy particles temperatures, and a slightly concave profile for the mass density. The radial velocity and the temperature gradients are mainly generated near the walls. The same holds for the only concave radial profile, i.e., the mass density increases severely near the walls, but the profile is almost flat in the center of the arc channel. Further, PLASIMO shows that the mass flux ρw and the dynamic pressure $\rho w^2 + p$ are constant over the radial axis, with only discrepancies at the walls. Therefore, flat profiles seem to be preferred. The no-slip condition (in PLASIMO: The velocity at the walls is set equal to zero) and the relatively low wall temperatures seem to prohibit flat profiles for the velocity and for the temperatures.

This analysis of the profiles obtained with PLASIMO shows that the quasi one-dimensional approach is sufficiently accurate.

VI. CONCLUSIONS

For transonic isentropic gases in convergent-divergent nozzles the sonic condition is situated at the smallest cross section. Using a quasi one-dimensional model, whose statements about Mach numbers were verified by the two-dimensional plasma simulation model PLASIMO, it has been shown that due to anisotropy (viscosity, heat addition, and ionization) Mach number values change and the sonic condition moves downstream. Expressions have been given to find at which location the Mach number equals unity.

ACKNOWLEDGMENTS

The simulation results of this work are part of a collaborative effort with G.M. Janssen on the plasma simulation program PLASIMO at the Eindhoven University of Technology. This investigation is sponsored by Euratom-F.O.M. and the Eindhoven University of Technology (TUE). The program is also supported by a F.O.M. Rolling Grant, “Stichting Technische Wetenschappen” (STW), and The Netherlands Organization for Scientific Research (NWO).

¹G. M. W. Kroesen, D. C. Schram, and J. C. M. de Haas, *Plasma Chem. Plasma Process.* **10**, 531 (1990).

²J. C. M. de Haas, *Non-equilibrium in flowing atmospheric plasmas*, thesis (Eindhoven University of Technology, 1986).

³R. F. G. Meulenbroeks, A. J. van beek, A. J. G. van Helvoort, M. C. M. van de Sanden, and D. C. Schram, *Phys. Rev. E* **49**, 4397 (1994).

⁴M. J. de Graaf, R. P. Dahiya, F. J. de Hoog, M. J. F. van de Sande, and D. C. Schram, *J. Phys. (Paris), Colloq.* **51**, C5 (1990).

⁵Edited by M. J. Thompson, Y. Hamakawa, and P. G. LeComber, *Amorphous Silicon Technology, Materials Research Society Symposium Proceedings*, Vol. 258 (Materials Research Society, Pittsburgh, 1992).

- ⁶J. J. Beulens, A. T. M. Wilbers, M. Haverlag, G. S. Oehrlein, G. M. W. Kroesen, and D. C. Schram, *J. Vac. Sci. Technol. A* **10**, 2387 (1992).
- ⁷K. T. A. L. Burm, W. J. Goedheer, J. A. M. van der Mullen, G. M. Janssen, and D. C. Schram, *Plasma Sources Sci. Technol.* **7**, 395 (1998).
- ⁸M. J. de Graaf, R. Severens, R. P. Dahiya, M. C. M. van de Sanden, and D. C. Schram, *Phys. Rev. E* **48**, 2098 (1993).
- ⁹R. F. G. Meulenbroeks, D. C. Schram, L. J. M. Jaegers, and M. C. M. van de Sanden, *Phys. Rev. Lett.* **69**, 1379 (1992).
- ¹⁰K. T. A. L. Burm, W. J. Goedheer, and D. C. Schram, The isentropic exponent in plasmas, *Phys. Plasmas* **6**, 2622 (1999).
- ¹¹P. H. Oosthuizen and W. E. Carscallen, *Compressible Fluid Flow* (McGraw-Hill, London, 1997).
- ¹²R. P. Benedict, *Fundamentals of Gas Dynamics* (Wiley, New York, 1983).
- ¹³J. A. Owczarek, *Fundamentals of Gas Dynamics* (International Textbook Company, Scranton, Pennsylvania, 1964).
- ¹⁴W. Bober and R. A. Kenyon, *Fluid Mechanics* (Wiley, Chichester, 1980).
- ¹⁵V. L. Streeter, E. B. Wylie, and K. W. Bedford, *Fluid Mechanics* (McGraw-Hill, New York, 1998).
- ¹⁶E. Becker, *Gasdynamik* (B. G. Teubner Verlagsgesellschaft, Stuttgart, 1965).
- ¹⁷S. Schreier, *Compressible Flow* (Wiley, New York, 1982).
- ¹⁸M. Mitchner and C. H. Kruger, *Partially Ionized Gases* (Wiley, Chichester, 1973).
- ¹⁹G. M. Janssen, J. van Dijk, D. A. Benoy, M. A. Tas, K. T. A. L. Burm, J. A. M. van der Mullen, W. J. Goedheer, and D. C. Schram, *Plasma Sources Sci. Technol.* **8**, 1 (1999); J. J. Beulens, D. Milojevic, D. C. Schram, and P. M. Vallinga, *Phys. Fluids B* **3**, 2548 (1991).