

Determination of specific cake resistance with a new capillary suction time (CST) apparatus

Citation for published version (APA):

Herwijn, A. J. M., Heij, la, E. J., Ijzermans, J. J., Coumans, W. J., & Kerkhof, P. J. A. M. (1995). Determination of specific cake resistance with a new capillary suction time (CST) apparatus. *Industrial and Engineering Chemistry Research*, 34(4), 1310-1319. <https://doi.org/10.1021/ie00043a036>

DOI:

[10.1021/ie00043a036](https://doi.org/10.1021/ie00043a036)

Document status and date:

Published: 01/01/1995

Document Version:

Publisher's PDF, also known as Version of Record (includes final page, issue and volume numbers)

Please check the document version of this publication:

- A submitted manuscript is the version of the article upon submission and before peer-review. There can be important differences between the submitted version and the official published version of record. People interested in the research are advised to contact the author for the final version of the publication, or visit the DOI to the publisher's website.
- The final author version and the galley proof are versions of the publication after peer review.
- The final published version features the final layout of the paper including the volume, issue and page numbers.

[Link to publication](#)

General rights

Copyright and moral rights for the publications made accessible in the public portal are retained by the authors and/or other copyright owners and it is a condition of accessing publications that users recognise and abide by the legal requirements associated with these rights.

- Users may download and print one copy of any publication from the public portal for the purpose of private study or research.
- You may not further distribute the material or use it for any profit-making activity or commercial gain
- You may freely distribute the URL identifying the publication in the public portal.

If the publication is distributed under the terms of Article 25fa of the Dutch Copyright Act, indicated by the "Taverne" license above, please follow below link for the End User Agreement:

www.tue.nl/taverne

Take down policy

If you believe that this document breaches copyright please contact us at:

openaccess@tue.nl

providing details and we will investigate your claim.

Determination of Specific Cake Resistance with a New Capillary Suction Time Apparatus

Arend J. M. Herwijn, Eric J. La Heij, Juul J. IJzermans, W. Jan Coumans, and Piet J. A. M. Kerkhof*

Department of Chemical Engineering, Laboratory of Separation Technology, FT-hall, P.O. Box 513, Eindhoven University of Technology, 5600 MB Eindhoven, The Netherlands

The capillary suction time (CST) apparatus has been studied both theoretically and experimentally. First, a theoretical model is presented for the description of the liquid flow in a capillary suction time apparatus. Second, to obtain reliable reproducible experimental data, a new CST apparatus has been developed. The filter paper, used as a capillary medium in the conventional CST apparatus, is replaced by ceramics, and the position of the liquid front is determined continuously by measuring the electrical resistance of (the wetted) ceramics as a function of time. As a consequence the theoretical model can be checked far better with the experimental results than with the conventional CST apparatus, which determines the position of the liquid front at only two fixed positions. Specific cake resistances can be determined by use of the presented model and the new equipment, using the right properties (permeability and porosity) and dimensions of the ceramic slab (thickness). The dewatering behavior of unflocculated and flocculated sludge and the effect of slurry concentrations can be investigated.

Introduction

Since it is very likely that in the near future the production of sewage sludge will increase and the possibilities of disposing sewage sludge will decrease, it is very important to find a way to reduce the mass and volume of sewage sludge. For this it is necessary to investigate the fundamental aspects of mechanical dewatering of sewage sludge. The capillary suction time (CST) apparatus is usually used to determine the dewaterability of sewage sludge in a rapid manner.

CST was presented for the first time by Baskerville and Gale (1968). Since the proposal of Baskerville and Gale (1968), several investigators discussed CST problems (Leu, 1981; Unno et al., 1981; Vesilind, 1988; Vesilind et al., 1988; Dohányos et al., 1988; Tiller et al., 1990; Lee and Hsu, 1992, 1993). A theoretical model describing liquid flow in a CST apparatus and some experimental results were presented in all of these papers.

The purpose of the research presented in this paper can be subdivided into three subjects: (1) to deduce a theoretical model that describes the position of the liquid front in a CST apparatus. With the model an average specific cake resistance can be calculated from experimental data; (2) to develop a continuous CST apparatus with which reliable reproducible data can be obtained; (3) to carry out experiments to verify the model calculations and to determine the average specific cake resistance of flocculated and unflocculated sewage sludges. The advantage of a specific cake resistance is that it is an intrinsic value, while the conventional CST values change, e.g., with the slurry concentration. CST values reported without the slurry concentration could therefore be misinterpreted.

The Principle of CST Measurement

The conventional CST apparatus (Baskerville and Gale, 1968) is an instrument with which one gets a

quick impression of the dewaterability of sewage sludge. A cylindrical tube is placed on a circular piece of filter paper, which is positioned between two perspex plates. When sludge, or any other suspension, is poured into the tube, liquid will be sucked into the paper under the influence of the capillary suction pressure and the sludge head. The liquid front will move in a radial direction, forming more or less an ellipse due to the grain of the paper (Schleicher & Schuell ref no. 382455). At two different positions ($r = 6$ and 13 mm) two electrodes are fixed in the perspex plates surrounding the filter paper. When the liquid front arrives at the first electrode, an electrical signal will be given to a chronometer whereupon time measurement will start. When the liquid front arrives at the second electrode, the time measurement will end. The time needed to move the liquid front from the first to the second electrode is called the "capillary suction time", abbreviated CST. From this CST the dewaterability of the suspension can be estimated; a small CST implies a good dewaterability.

A Theoretical Model Describing the Liquid Flow in a CST Apparatus

The dewatering process in a CST apparatus is in fact a filtration process in which the capillary pressure of the filter paper is the main driving force. The dewatering in a CST apparatus consists of two consecutive processes, namely the filtration of sludge in the cylindrical tube and the penetration of filtrate into the filter medium. It is assumed that the structure of the filter medium is isotropic so that the shape of the liquid front will be circular.

The model is based on four equations. Two equations describe the pressure difference across the sludge layer, and two equations describe the pressure difference across the filter medium.

1. According to Darcy's law the following equation is obtained for the pressure difference across the sludge cake.

* Author to whom correspondence should be addressed.

$$\Delta P_s = \frac{1}{A} \frac{\eta L}{K_s} \frac{dV}{dt} = \frac{\eta \alpha_{av} C_{av}}{2A^2} \frac{dV^2}{dt} \quad (1)$$

$$\alpha_{av} = \frac{1}{C_{av} K_s}$$

where ΔP_s is the pressure difference across the sludge cake, A the area of the cross section of the inner CST tube, η the viscosity of the filtrate, L the thickness of the sludge cake, K_s the average permeability of the sludge cake, V the filtrate volume, C_{av} the cake mass deposited per unit filtrate volume, and α_{av} the average specific cake resistance. The initial condition is: $t = 0$; $V = 0$.

2. The pressure difference across the sludge cake is the sum of the head exerted by the sludge layer and the suction pressure exerted by the filter medium.

$$\Delta P_s = \rho_s g H + \frac{F'}{A} \quad (2)$$

where ρ_s is the sludge density, g the gravitational acceleration, H the height of the sludge layer, and F' the suction force exerted by the filter medium under the CST tube.

3. As in a CST apparatus liquid flows in radial direction, Darcy's law must be expressed in the following manner:

$$\frac{dP}{dr} = - \frac{\eta}{2\pi r h K_F} \frac{dV}{dt} \quad r = r_0 \quad P = P_0 \quad (3)$$

where P is the hydraulic pressure, P_0 the hydraulic pressure at position r_0 , r the position of the liquid front at time t , r_0 the position of the liquid front at time $t = 0$ (i.e., the internal radius of CST tube), h the thickness of the filter medium, and K_F the permeability of the filter medium.

Solving this differential equation gives

$$P_0 - P = \Delta P_F = \frac{\eta}{2\pi h K_F} \ln\left(\frac{r}{r_0}\right) \frac{dV}{dt} \quad (4)$$

In this equation ΔP_F expresses the pressure difference across the filter medium.

4. The last of the four equations is analogous to eq 2.

$$2\pi r h \Delta P_F = 2\pi r h \beta \gamma \cos \theta - F' \quad (5)$$

where γ is the interfacial tension of the filtrate and β the reciprocal hydraulic radius. The product $\beta \gamma \cos \theta$ is equal to the capillary suction pressure P_{cap} . The reciprocal hydraulic radius β is introduced since the driving force for the flow of liquid in a capillary medium depends on the measure of wetting of the surface by the liquid. Combination of eqs 1, 3, 6, and 7, and where the area of the cross section of the CST tube is introduced as πr_0^2 , leads to

$$\rho_s g H \pi r_0^2 = \frac{\eta \alpha_{av} C_{av}}{2\pi r_0^2} \frac{dV^2}{dt} + \frac{2\pi \eta h r \ln(r/r_0)}{2\pi h K_F} \frac{dV}{dt} - 2\pi r h \beta \gamma \cos \theta \quad (6)$$

The liquid flow in the capillary medium is treated as a displacement process. The liquid volume in the capil-

lary medium is equal to the porosity times the wetted ceramic volume. This is equal to

$$V = \epsilon h \pi (r^2 - r_0^2) \quad (7)$$

Equation 6 can now be written as

$$\rho_s g H r_0^2 = \frac{\eta \alpha_{av} C_{av} \epsilon^2 h^2}{2r_0^2} \frac{d(r^2 - r_0^2)^2}{dt} + \frac{r \ln(r/r_0) \eta \epsilon h}{K_F} \frac{d(r^2 - r_0^2)}{dt} - 2r h \beta \gamma \cos \theta \quad (8)$$

with the initial condition $t = 0$, $r = r_0$.

If eq 8 is rewritten, the basic equation, describing the movement of liquid in a CST apparatus, is obtained

$$\rho_s g H r_0^2 + 2r h \beta \gamma \cos \theta = \left(\frac{2r^3 \eta \alpha_{av} C_{av} \epsilon^2 h^2}{r_0^2} - 2\eta \alpha_{av} C_{av} \epsilon^2 h^2 r + \frac{2r^2 \ln(r) \eta \epsilon h}{K_F} - \frac{2r^2 \ln(r_0) \eta \epsilon h}{K_F} \right) \frac{dr}{dt} \quad (9)$$

with the initial condition $t = 0$, $r = r_0$.

Equation 9 can only be solved numerically. A result of this numerical solution is presented in Figure 1.

The constants in this numerical solution were chosen to be physically reasonable for sludge and ceramics used in the newly developed CST apparatus (see Experimental Results and Discussion section), i.e., $\rho_s = 1030 \text{ kg m}^{-3}$, $\eta = 10^{-3} \text{ N s m}^{-2}$, $\epsilon = 0.46$, $H = 0.06 \text{ m}$, $\alpha_{av} = 10^{13} \text{ m kg}^{-1}$, $P_{cap} = 50 \text{ kPa}$, $C_{av} = 18 \text{ kg m}^{-3}$, $h = 0.001 \text{ m}$, $K_F = 9.6 \times 10^{-15} \text{ m}^2$, $r_0 = 0.006 \text{ m}$.

The models presented by Unno et al. (1983) and Leu (1981) are based on the same basic equations. However, Unno et al. failed to give the right solution of the model and Leu never solved his model showing the position of the liquid front as a function of time.

Parameter Studies

The influence of the capillary pressure P_{cap} , the filter medium porosity ϵ , and the average specific cake resistance α_{av} on the model calculations has been investigated with the presented CST model. The constants used in these parameter studies were given in the previous section.

The Influence of the Capillary Pressure. The capillary pressure is a driving force for liquid flow in the capillary medium. Therefore one should expect an increase of the liquid front velocity with an increasing capillary pressure. This is shown in Figure 2.

The capillary pressure was varied from 10 to 100 kPa. The calculated radial position of the liquid front at a time t increases, as is expected, with an increasing capillary pressure.

The Influence of the Porosity of the Filter Medium. The consequences of a variation of the porosity of the filter medium ϵ for the calculated radial position of the liquid front as a function of time are not evident, because the capillary pressure P_{cap} and the filter medium permeability K_F both depend on the porosity ϵ . The capillary pressure depends on the reciprocal hydraulic radius β , the interfacial tension of the filtrate γ , and the contact angle θ capillary medium/filtrate according to the following formula:

$$P_{cap} = \beta \gamma \cos \theta \quad (10)$$

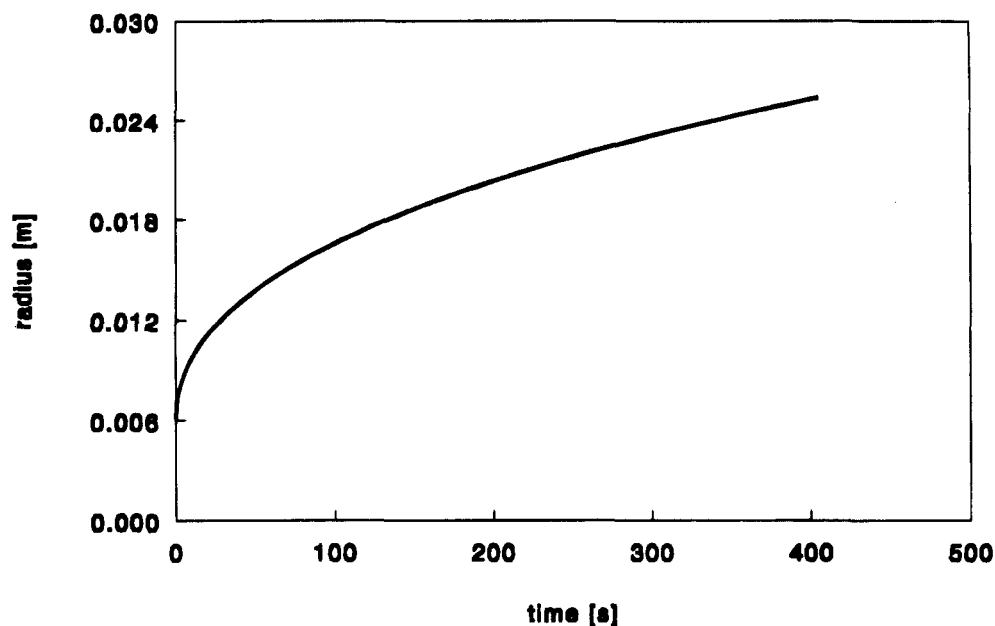

Figure 1. Result of the numerical solution of the CST model.

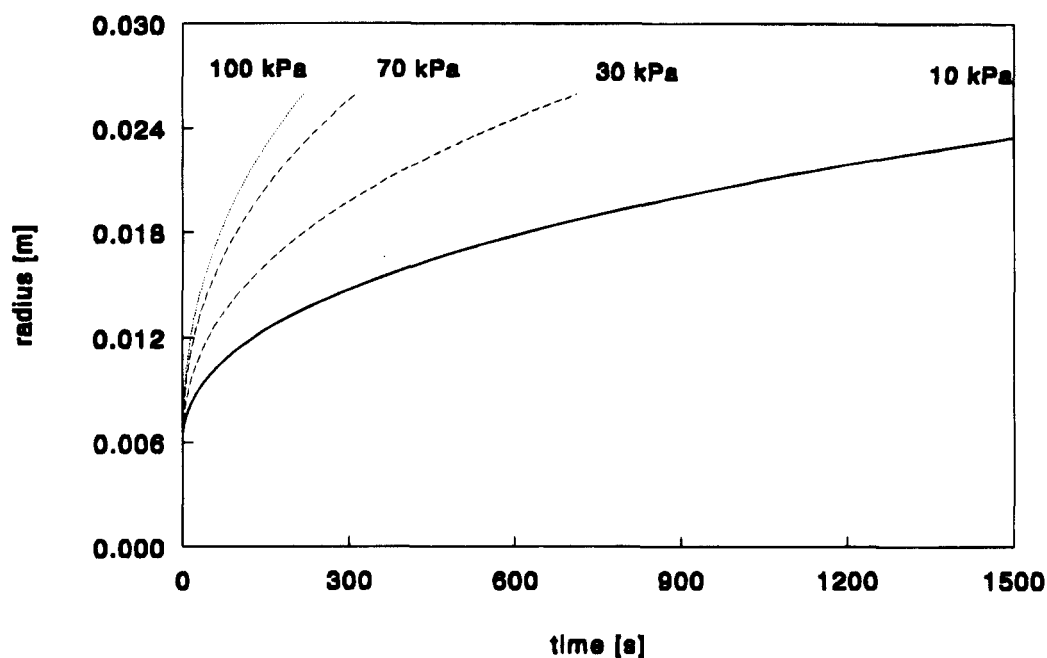

Figure 2. The influence of the capillary pressure.

The reciprocal hydraulic radius β is given by

$$\beta = \frac{a_v(1 - \epsilon)}{\epsilon} \quad (11)$$

where a_v represents the specific surface area of the ceramics. Substitution of eq 11 into eq 10 yields the dependence of the capillary suction pressure on the porosity:

$$P_{\text{cap}} = \frac{a_v(1 - \epsilon)}{\epsilon} \gamma \cos \theta \quad (12)$$

The permeability can be calculated with the Kozeny–Carman equation. This equation has been proved valid experimentally for the capillary medium used in the newly developed CST apparatus (IJzermans, 1992). Results of calculations are shown in Figure 3.

The porosity was varied from 0.3 to 0.8. The liquid front velocity is a maximum for a capillary medium porosity of 0.5, when it is taken into account that the variation of the porosity has consequences for the values of the capillary pressure and the filter medium permeability.

In the newly developed CST apparatus ceramics is used as a capillary medium (see New CST Apparatus section). The ceramic slab is characterized by the structure parameters of porosity, permeability, and capillary suction pressure. The porosity can be determined with mercury porosimetry, permeability with a permeability cell, and the capillary suction pressure by conducting a CST experiment with demineralized water (see Experimental Results and Discussion section).

The Influence of the Average Specific Cake Resistance α_{av} . The cake resistance α_{av} represents the liquid flow resistance in the CST tube, since there has been a buildup of a sludge cake. Therefore one should

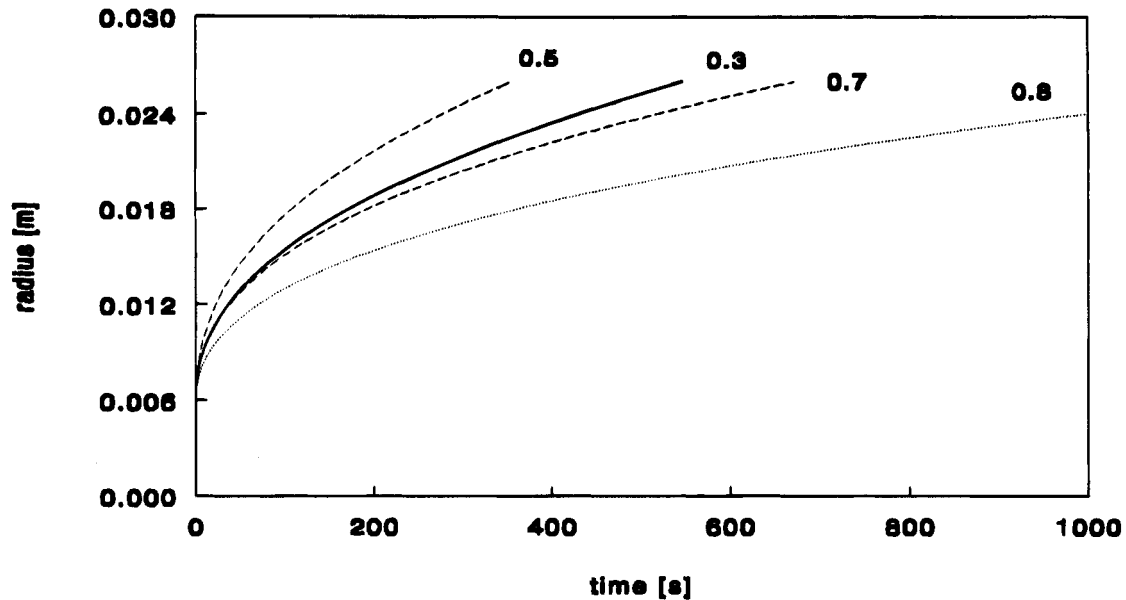

Figure 3. The influence of the porosity ϵ of the filter medium.

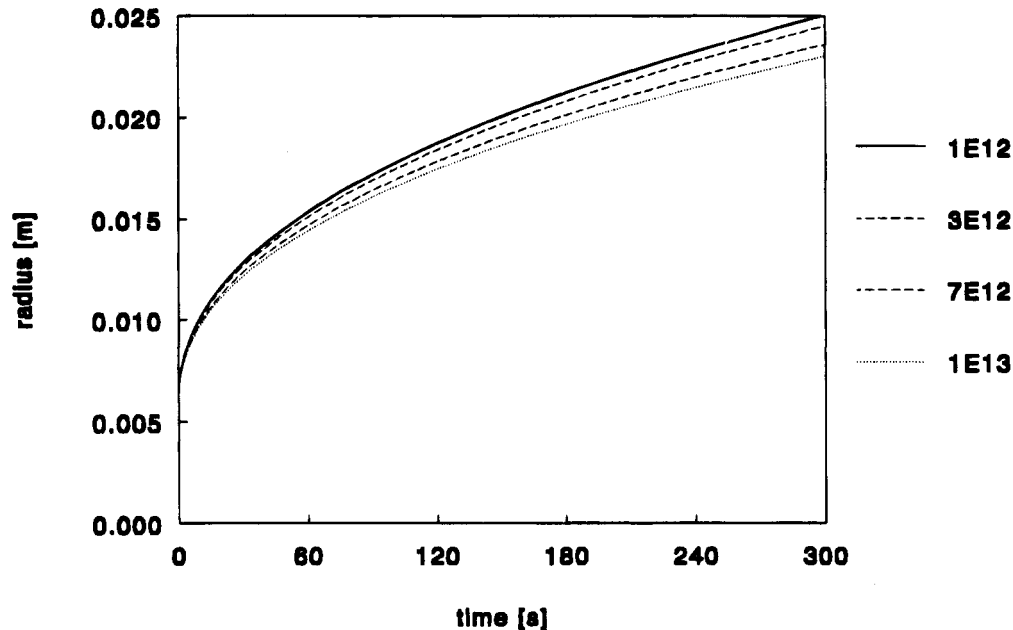

Figure 4. The influence of the specific cake resistance α_{av} .

expect a decrease of the distance covered at a certain time by the liquid front with an increase of the average specific cake resistance α_{av} . Results of calculations shown in Figure 4 confirm this expectation.

The specific cake resistance α_{av} was varied from 10^{12} to 10^{13} m kg^{-1} . The calculated radial position of the liquid front at a time t decreases with an increasing cake resistance α_{av} . The value of K_F used in this parameter study is 9.6×10^{-15} m^2 . As can be seen in Figure 4, the differences between the curves are relatively small. To increase this difference a filter medium with a higher permeability should be used. The consequence of a smaller permeability of the filter medium is that the influence of the specific cake resistance on the radial liquid front position as a function of time is negligible.

From these parameter examinations several conclusions can be drawn. First, in order to calculate an average specific cake resistance, the permeability of the sludge cake must be small in comparison with the permeability of the filter medium. Second, it is obvious that the capillary pressure is an important driving force

for the liquid flow in a capillary medium. The hydrostatic driving force induced by the sludge head is negligibly small (± 600 Pa) in comparison with the capillary driving pressure ($\pm 10^5$ Pa; see Experimental Results and Discussion section). Finally, it can be concluded that the porosity of the capillary medium has great influence on the results of the model calculations and experiments, because the porosity influences the reciprocal hydraulic radius β and therefore the capillary pressure P_{cap} and at the same time the permeability of the filter medium K_F .

New CST Apparatus

Several apparatuses to measure the CST are described in the literature. The first apparatus, developed by Baskerville and Gale (1968), has been commercialized by Triton Electronics. Alternative CST apparatuses are known with which, for example, the CST must be determined visually by a radial scale drawn on the capillary medium (Leu, 1981) or by use of several

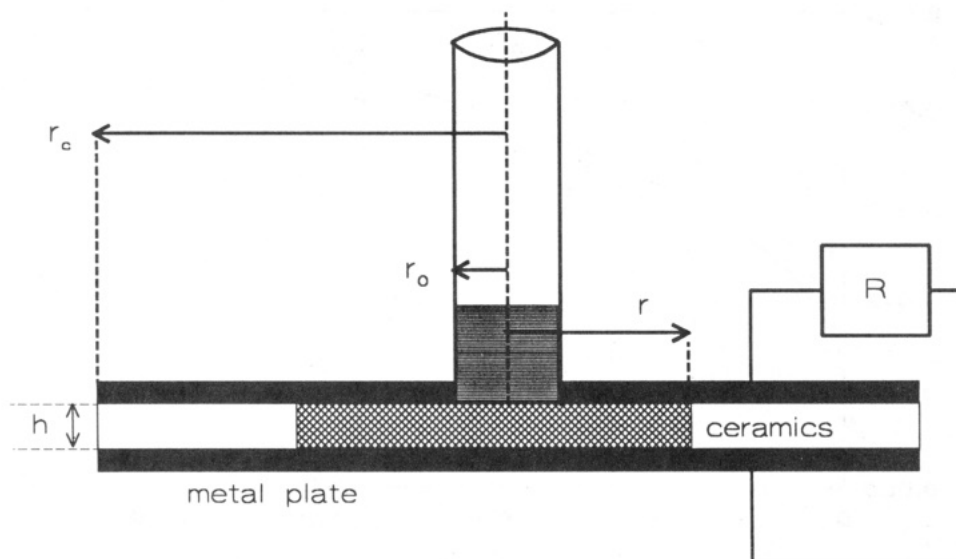

Figure 5. Schematic diagram of liquid movement in ceramics.

electrodes (Lee and Hsu, 1992, Unno et al., 1983). These instruments have two important properties in common. First, filter paper is used as a capillary medium. Second, the position of the liquid front is only measured discontinuously. Both properties imply several problems.

Filter paper is an anisotropic material, which implies that the liquid front will move with different velocities in different directions. As a result no circular liquid front, on which the model is based, will develop. Further, the reproducibility of the measurement will be small, because of the differences between the filter papers.

To check the presented CST model on the physical reality, more than two data points are required. A continuous method of measurement is the best option.

Two typical differences between the conventional and the new CST apparatus can be distinguished.

Filter Medium. Instead of filter paper, ceramics will be used as a capillary medium (pressed Al_2O_3 , initial particle size $\pm 50 \mu\text{m}$, pressing pressure 3000 bar, sintering temperature 1500°C). Since this capillary medium is isotropic, a circular liquid front will develop during a CST experiment. One can also expect the experiments to be reproducible. The required thickness of the ceramic slab is 1–2 mm; this thickness avoids slow saturation of the ceramic slab in the axial direction. The ceramic slab should be calibrated by determining its porosity and specific surface area with mercury porosimetry. To reproduce the results presented, ceramic media having a porosity equal to 0.46 and a specific surface area a_v of $7 \times 10^6 \text{ m}^2 \text{ m}^{-3}$ should be used.

Method of Measurement. The new continuous method of measurement is based on the fact that the electrical resistance of ceramics will decrease when the pores are filled up with water or any other liquid. The new CST apparatus is shown schematically in Figure 5. The ceramic slab is tightened between two copper plates. The copper plates act as electrodes. A multimeter (measuring frequency 10 kHz), connected to the electrodes, continuously measures the electrical resistance of the ceramic slice. The experimental data are transferred to a computer. The sampling time of the computer is 1 s. When liquid is sucked into the ceramic slab, a decrease of electrical resistance of the capillary medium will be measured. At the end of the experiment

a constant resistance is reached, which depends on the type of ceramics and ionic strength of the liquid. From the measured resistance as a function of time the radial position of the liquid front as a function of time can be calculated. The situation at a certain moment during a CST experiment is also shown in Figure 5. The shaded area represents the part of the ceramic slice that has been filled up with water, and the white area represents dry ceramics. r_0 equals the position of the liquid front at time $t = 0$, r equals the position at time t , and r_c represents the radius of the ceramic slab. This situation at a time t can be interpreted as a parallel connection of the electrical resistances of the dry part of the slice R_d and the wetted part of the ceramic slice R_w , respectively. The total resistance of this system R_{tot} can therefore be represented as

$$R_{\text{tot}} = \frac{R_d R_w}{R_w + R_d} \quad (13)$$

The position of the liquid front at an arbitrary time t can now be calculated from the measured resistance R_{tot} according to the following equation:

$$r(t) = \sqrt{\frac{\rho_w}{\rho_d - \rho_w} \left[\frac{\rho_d h}{R_{\text{tot}}(t) \pi} - r_c^2 \right]} \quad (14)$$

where ρ_d and ρ_w represent the specific electrical resistance of dry and wetted ceramics, respectively. It is essential that the whole experimental setup is tightened in a clamping-screw, see Figure 6. This setup assures good contact both between the wetted ceramics and the copper plates and between the tube and the ceramics (no leakage). To avoid pollution of the ceramics with small sludge particles, a small filter paper (6 mm) is placed between the tube and the ceramic slab.

Experimental Results and Discussion

Determination of Capillary Suction Pressure.

The capillary suction pressure P_{cap} of the circular ceramic slab ($r_c = 29 \text{ mm}$, $h = 1 \text{ mm}$, $\epsilon = 0.46$, $K_F = 9.589 \times 10^{-15} \text{ m}^2$) used in the experiments is an important system parameter. The capillary suction pressure is assumed to be uniform in all directions of

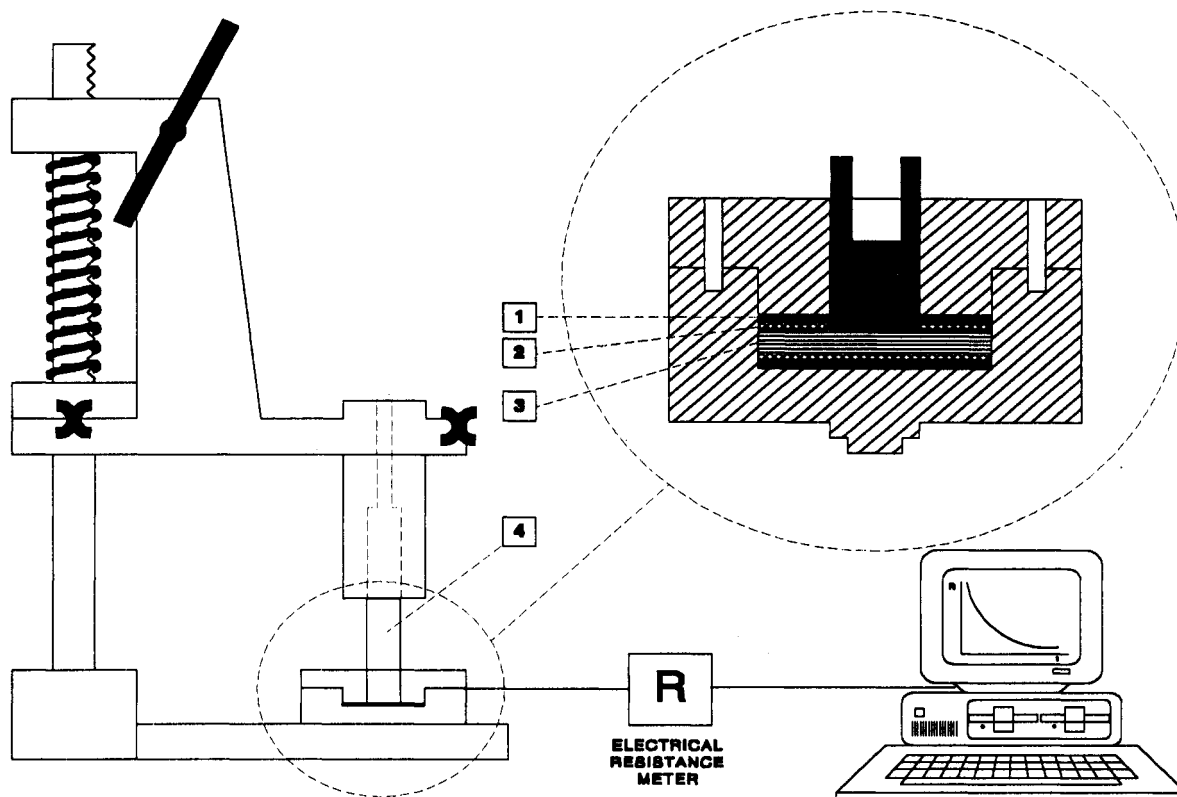

Figure 6. Whole experimental setup for new CST apparatus. (1) rubber, (2) copper electrode, (3) ceramic slab, and (4) CST tube.

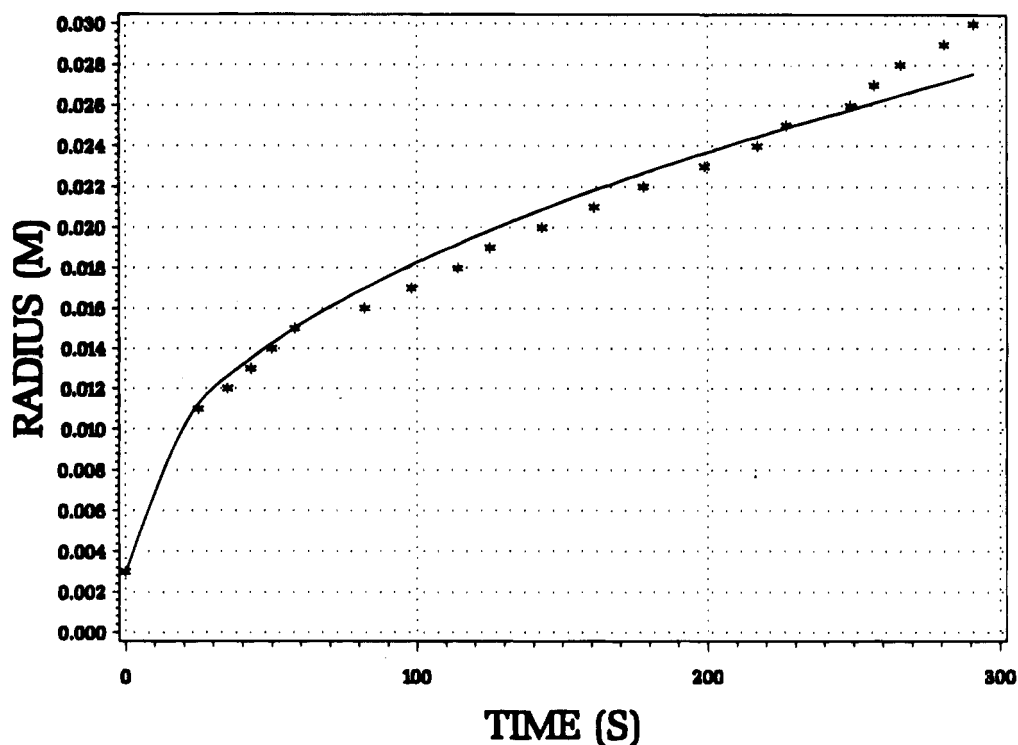

Figure 7. CST experiment with water to determine capillary suction pressure; position of liquid front was measured visually.

the ceramic slab and independent of time. In an experiment a colored water solution is poured into the CST tube and the position of the wet front radius is measured by reading the position with a scale. In this way, the position of the wet front is recorded directly. If only pure liquid is used in the CST experiment (i.e., there is no sludge cake formation), the first two terms on the right-hand side of eq 9 can be deleted. The

mathematical model is then used to obtain the capillary pressure. The result of this experiment is shown in Figure 7.

A model calculation yields a value for the capillary suction pressure of $1.08 \times 10^5 \text{ N m}^{-2}$.

Another way to determine the capillary pressure is to carry out CST experiments with demineralized water. The radial position of the liquid front as a function of time

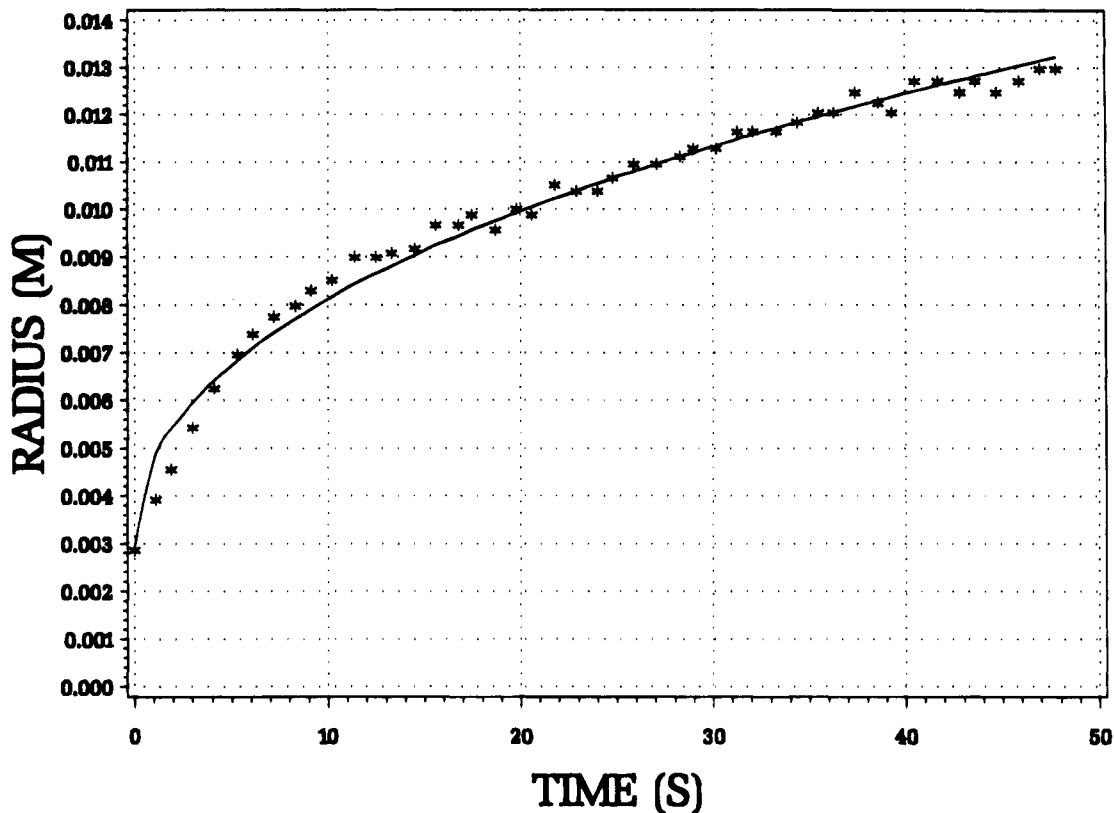

Figure 8. CST experiment with water to determine capillary pressure; position of liquid front was determined indirectly by use of electrical resistance of ceramics.

is determined indirectly by measuring the electrical resistance of the ceramic slab as a function of time according to eq 14. The specific electrical resistance of dry ceramics ρ_d equals $10^{11} \Omega \text{ m}$. The specific electrical resistance of wetted ceramics is calculated from the measured resistance at the end of the experiment, which depends on the electrical conductivity of the filtrate and the geometry of the slab. It is assumed that the ceramic slab is fully saturated. The experimental result is fitted with the theoretical model to calculate the capillary suction pressure (Figure 8). The result of the calculation is $P_{\text{cap}} = 0.884 \times 10^5 \text{ N m}^{-2}$. It can be concluded that both experiments showed satisfactory agreement. Henceforth in model calculations a value of the capillary suction pressure of 10^5 N m^{-2} is assumed.

Reproducibility. In Figure 9 three CST experiments carried out under the same process conditions with unflocculated sludge are shown. In these experiments the same ceramic slab was used. It can be seen that the reproducibility is reasonable. Model calculations yield values of the specific cake resistance of 4.39×10^{15} , 3.64×10^{15} , and $3.01 \times 10^{15} \text{ m kg}^{-1}$. One should take notice that sewage sludges used in the experiments are biological in nature. Due to microbial activity the sludge composition may change with time and negatively influence the reproducibility. One should expect a better reproducibility for nonbiological sludges. However, CST tests with nonbiological sludges have not been conducted.

Determination of Specific Cake Resistance. CST experiments have been carried out with sewage sludge originating from the Eindhoven waste water treatment plant. In these experiments a cylindrical perspex column with an inner radius of 3 mm was used. A larger column radius increases the filtration area and therefore also the liquid flow through the cake and the capillary medium. The sampling time in that case must

be smaller than 1 s in order to get a reliable fit of the measured curve. At the start of an experiment 3.5 mL of a sewage sludge sample (dry solids content 1.9 wt %) is poured into the tube. The experiment ends when the ceramic slab has been fully saturated. In Figure 10 two experimental results are shown. The stars represent the result of an experiment carried out with a sample flocculated with 10 wt % FeCl_3 and 20 wt % Ca(OH)_2 on a dry solids base. The dots represent the result of an experiment carried out with unflocculated sludge. It is clear that flocculation of a sludge sample accomplishes a decrease of the time needed for the liquid front to move a certain distance. The lines in the graph represent the results of the model calculations. A specific cake resistance is determined from fitting the experimental results with the theoretical model. Results of model calculations are

$$\alpha_{\text{av,unfloculated}} = 1.24 \times 10^{15} \text{ m kg}^{-1}$$

$$\alpha_{\text{av,floculated}} = 2.56 \times 10^{13} \text{ m kg}^{-1}$$

As expected, the specific cake resistance of unflocculated sludge is much higher than the cake resistance of a flocculated sample. At the beginning of the experiment, the model overestimates the velocity with respect to the experiment. This is possibly caused by the resistance of the small filter paper positioned under the perspex column. The new CST device provides the possibility to determine a specific cake resistance of flocculated as well as unflocculated sludges. Unflocculated sludges are hard-to-filter suspensions in a batch filtration experiment.

Effect of Slurry Concentration. In Figure 11 the movement of the liquid front as a function of time for two different slurry concentrations is shown. The

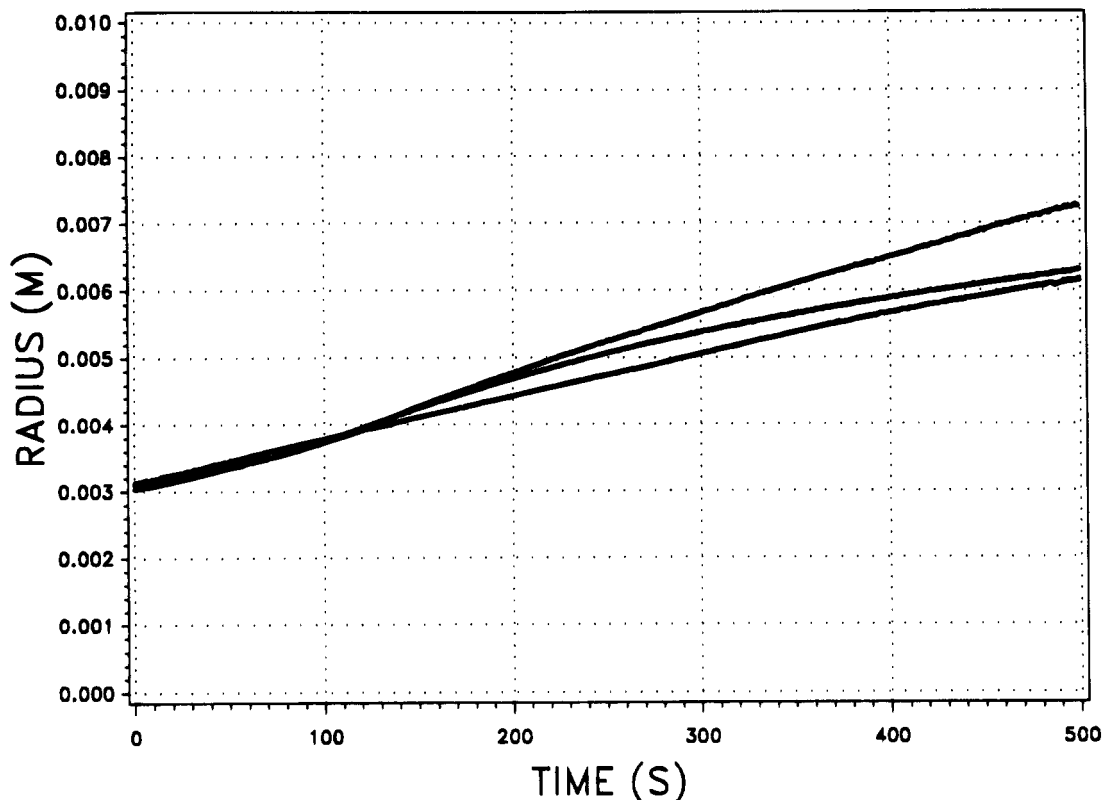

Figure 9. Results of three identical experiments carried out with unflocculated Eindhoven sludge.

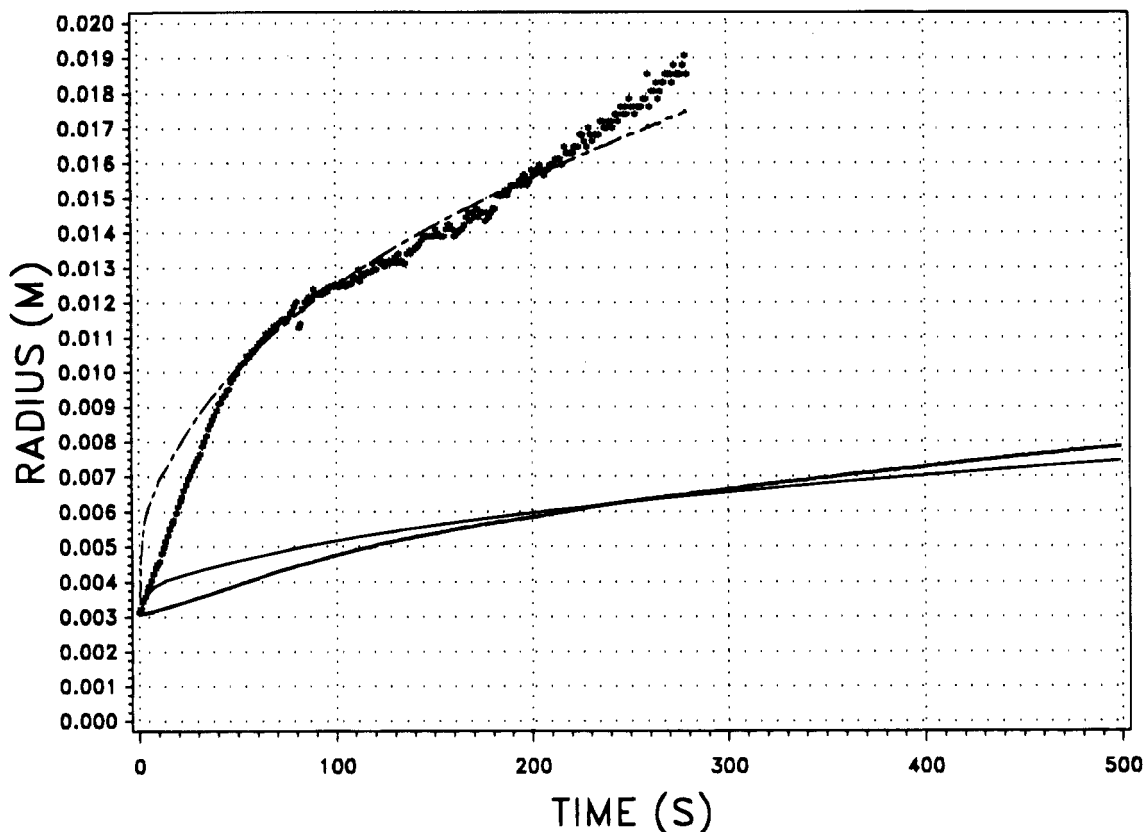

Figure 10. Experimental results of CST experiments. Dots, unflocculated Eindhoven sludge; stars, flocculated 10 wt % FeCl_3 /20 wt % $\text{Ca}(\text{OH})_2$; lines, results of model calculations.

movement of the liquid front is slower when the slurry concentration increases. The calculated average specific cake resistance was in both cases $2.7 \times 10^{-15} \text{ m kg}^{-1}$. If only conventional CST values were reported, a large difference would be found. However, since for the calculations of the specific cake resistance the slurry

concentration is needed, the cake resistance is equal for both slurry concentrations. The intrinsic dewatering property is not changed. It may be concluded that effects of slurry concentrations also can be investigated with the new CST apparatus.

To correlate the calculated specific cake resistance

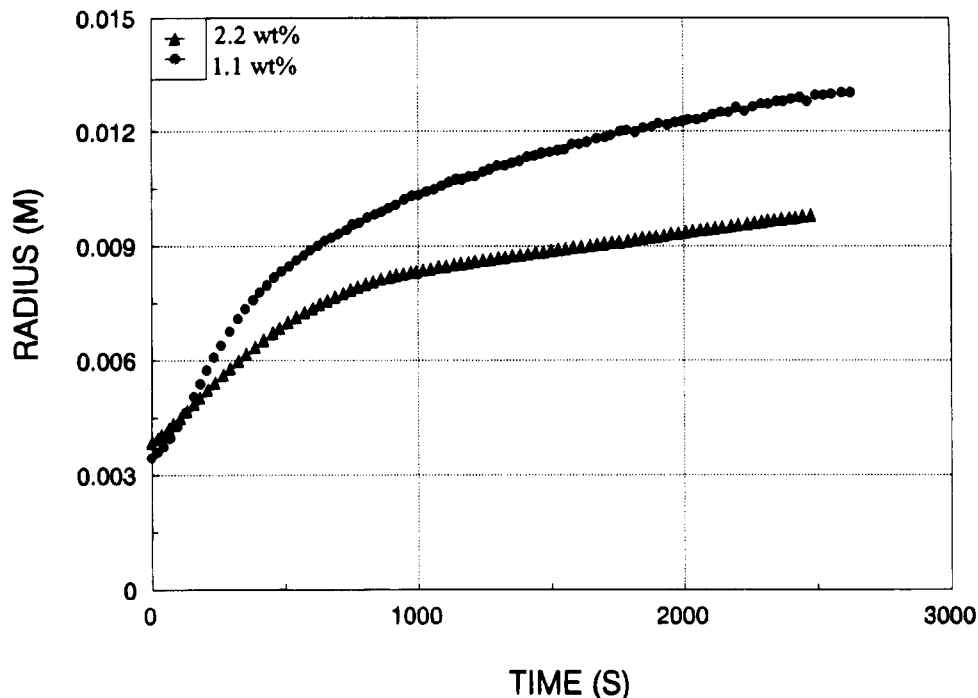

Figure 11. Wetted radius versus time for two different slurry concentrations. Unfloculated sludge.

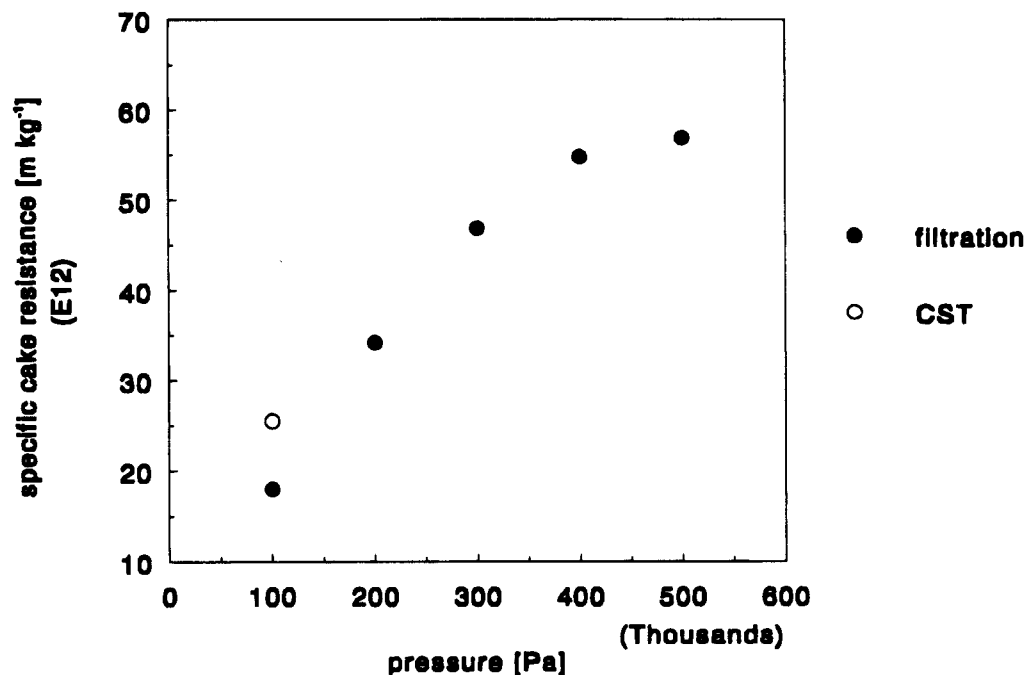

Figure 12. Average specific cake resistance versus pressure for normal filtration experiments and the new CST experiment.

from a CST experiment with normal batch filtration cake resistances, it is useful to carry out filtration experiments not only at 100 kPa (capillary suction pressure of used ceramics) but also at other pressures. As sludge is very compressible the average specific cake resistance depends on the pressure drop over the sludge cake. In Figure 12 results of normal filtration and CST experiments are shown. From Figure 12 it can be concluded that there is an acceptable correlation between normal filtration and CST experiments. The difference can be caused by possible sedimentation effects or wall friction effects which have more influence on a CST experiment than on normal filtration experiments, because of the smaller dimensions of the CST tube.

Conclusions

With the model presented and the new type of CST apparatus average specific cake resistances can be obtained for unfloculated as well as flocculated sludges. The newly developed CST instrument is based on continuously measuring the electrical resistance of a ceramic slab during filtrate penetration. The measured electrical resistance as a function of time is converted to a radial position of the liquid front as a function of time. Before any calculations can be made, several parameters of the ceramic porous medium have to be known. This implies the permeability, the capillary pressure, and the specific electrical resistance of the ceramics. It is of great importance that the permeability of the ceramics is high enough (10^{-14} – 10^{-15} m²) in

comparison with the permeability of the sludge cake ($10^{-15} - 10^{-17} \text{ m}^2$) in order to calculate a correct average specific resistance. The required thickness of the ceramic slab must be equal to 1–2 mm to avoid slow saturation in the axial direction. The slurry concentration does not influence the average specific resistance of the cake formed in the CST tube because of the low compressibility of the sludge at low applied pressures. However, the conventional CST value depends on the initial solids concentration of the sludge suspension.

Acknowledgment

The authors wish to thank P. M. H. Janssen for his indispensable help in carrying out many experiments and discussing problems and J. A. M. Denissen of TNO for his assistance in producing the ceramics. This work is financially supported by the Institute of Inland Water Management and Waste Water Treatment (DBW/RIZA) and the Foundation for Applied Waste Water Research (STOWA).

Nomenclature

α_v = specific surface area ($\text{m}^2 \text{ m}^{-3}$)
 A = area of the cross section of the inner CST tube (m^2)
 C_{av} = cake mass deposited per unit filtrate volume (kg m^{-3})
 F = suction force exerted by filter medium under CST tube (N)
 g = gravitational acceleration (m s^{-2})
 H = height of sludge layer (m)
 h = thickness of the filter medium (m)
 K_F = permeability of filter medium (m^2)
 K_s = permeability of sludge cake (m^2)
 L = thickness of the sludge layer (m)
 P = pressure (N m^{-2})
 P_{cap} = capillary suction pressure (N m^{-2})
 P_0 = pressure at position r_0 (N m^{-2})
 ΔP_F = pressure difference across the filter medium (N m^{-2})
 ΔP_s = pressure difference across the sludge cake (N m^{-2})
 r_0 = position liquid front at time $t = 0$ (i.e., internal radius CST tube) (m)
 r = position of the liquid front at time t (m)
 r_c = radius of ceramic slab (m)
 R = electrical resistance (Ω)
 R_d = electrical resistance of dry part of ceramic slab (Ω)
 R_{tot} = total electrical resistance of ceramic slab (Ω)

R_w = electrical resistance of wetted part of ceramic slab (Ω)

t = time (s)

V = filtrate volume (m^3)

Greek Symbols

α_{av} = average specific cake resistance (m kg^{-1})

β = reciprocal hydraulic radius (m^{-1})

γ = interfacial tension of filtrate (N m^{-1})

ϵ = porosity of the filter medium

η = viscosity of filtrate (N s m^{-2})

θ = contact angle filter medium / filtrate (N m^{-1})

ρ_d = specific electrical resistance of dry ceramics ($\Omega \text{ m}$)

ρ_n = specific electrical resistance of wetted ceramics ($\Omega \text{ m}$)

ρ_s = sludge density (kg m^{-3})

Literature Cited

- Baskerville, R. C.; Gale, R. S. A simple automatic instrument for determining the filterability of sewage sludge. *Water Pollut. Control* **1968**, *67*, 233–241.
- Dohányos, M.; Grau, P.; Sedláček, M. Interpretation of dewaterability measurements by capillary suction time (CST). *Water Sci. Technol.* **1988**, *20*, 265–267.
- IJzermans, J. J. Capillary suction time: Theorie & Praktijk. Ir. Dissertation (in Dutch), Eindhoven University of Technology, The Netherlands.
- Lee, D. J.; Hsu, Y. H. Fluid flow in capillary suction apparatus. *Ind. Eng. Chem. Res.* **1992**, *31*, 2379–2385.
- Lee, D. J.; Hsu, Y. H. Cake formation in capillary suction apparatus. *Ind. Eng. Chem. Res.* **1993**, *32*, 1180–1185.
- Leu, W. F. Capillary suction apparatus in cake filtration. Ph.D. Dissertation, University of Houston, 1981.
- Tiller, F. M.; Shen, Y. L.; Adin, A. Capillary suction theory for rectangular cells. *J. Water Pollut. Control Fed.* **1990**, *62*, 130–136.
- Unno, H.; Muraiso, H.; Akehata, T. Theoretical and experimental study of factors affecting Capillary Suction Time. *Water Res.* **1983**, *17*, 149–156.
- Vesilind P. A. Capillary suction time as a fundamental measure of sludge dewaterability. *J. Water Pollut. Control Fed.* **1988**, *60*, 215–220.
- Vesilind, P. A.; Davis, H. A. Using the capillary suction time device for characterizing sludge dewaterability. *Water Sci. Technol.* **1988**, *20*, 203–205.

Received for review May 31, 1994

Accepted January 4, 1995

IE940344W

Abstract published in *Advance ACS Abstracts*, March 1, 1995.