

WDM monitoring technique using adaptive blind signal separation

Citation for published version (APA):

Tangdionga, E., Calabretta, N., Sommen, P. C. W., & Dorren, H. J. S. (2001). WDM monitoring technique using adaptive blind signal separation. *IEEE Photonics Technology Letters*, 13(3), 248-250.
<https://doi.org/10.1109/68.914336>

DOI:

[10.1109/68.914336](https://doi.org/10.1109/68.914336)

Document status and date:

Published: 01/01/2001

Document Version:

Publisher's PDF, also known as Version of Record (includes final page, issue and volume numbers)

Please check the document version of this publication:

- A submitted manuscript is the version of the article upon submission and before peer-review. There can be important differences between the submitted version and the official published version of record. People interested in the research are advised to contact the author for the final version of the publication, or visit the DOI to the publisher's website.
- The final author version and the galley proof are versions of the publication after peer review.
- The final published version features the final layout of the paper including the volume, issue and page numbers.

[Link to publication](#)

General rights

Copyright and moral rights for the publications made accessible in the public portal are retained by the authors and/or other copyright owners and it is a condition of accessing publications that users recognise and abide by the legal requirements associated with these rights.

- Users may download and print one copy of any publication from the public portal for the purpose of private study or research.
- You may not further distribute the material or use it for any profit-making activity or commercial gain
- You may freely distribute the URL identifying the publication in the public portal.

If the publication is distributed under the terms of Article 25fa of the Dutch Copyright Act, indicated by the "Taverne" license above, please follow below link for the End User Agreement:

www.tue.nl/taverne

Take down policy

If you believe that this document breaches copyright please contact us at:

openaccess@tue.nl

providing details and we will investigate your claim.

WDM Monitoring Technique Using Adaptive Blind Signal Separation

E. Tangdionga, *Student Member, IEEE*, N. Calabretta, *Student Member, IEEE*, P. C. W. Sommen, and H. J. S. Dorren

Abstract—We present a cost-effective method to monitor the performance of wavelength-division-multiplexed (WDM) channels. The method is based on simple optical signal processing in a combination with electronic signal processing. The photocurrent of a detected (multichannel) optical signal is analyzed using an adaptive blind signal separation method. A maximum data decorrelation criterion is used to separate the WDM channels. We show experimentally that four WDM channels can be reconstructed accurately by this numerical method.

Index Terms—Cross-connects, monitoring, wavelength-division multiplexing.

I. INTRODUCTION

IT IS WELL known that transparent optical networks require sufficient monitoring of the wavelength-division-multiplexed (WDM) channels to provide the network management with adequate information about the quality of the transported signal [1]. Preferably, this information is obtained without affecting the transparency of the network. Moreover, it is important that the monitoring method can be implemented at the network node itself and that the monitoring method is independent of the number of wavelength channels.

Several methods for monitoring the signal based on, for example, tunable filters [2], phased array with diffraction gratings [3], [4], and pilot tones [5] have been investigated. In [6], a signal monitoring method is presented that is based on a combination of simple optical processing and complicated electronic processing. It is shown in [6] that a probability density function (PDF) related to the eye pattern of a WDM signal can be used to obtain information of the optical power and the noise levels of optical channels. A disadvantage of the method is that only a limited number of WDM channels can be analyzed with an accurate estimation of the noise of the distinct WDM channels.

In this letter, we improve the electronic signal processing of [6] in such a way that complete bit patterns of the WDM channels can be reconstructed by analyzing the photocurrents with a symmetric adaptive decorrelation (SAD) scheme [7]. The algorithm separates the signals through a maximum data decorre-

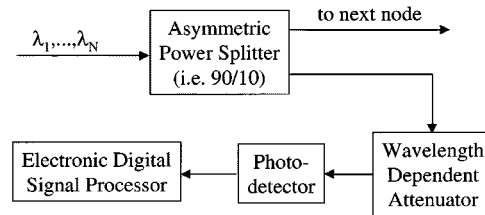

Fig. 1. Optical monitoring for a WDM system.

lation, similar to the analysis presented in [3]. The concepts of our method are described theoretically and experimentally verified for four WDM channels. Theoretical analysis shows that the method also works for a larger number of channels.

II. SYSTEM DESCRIPTION

Fig. 1 shows a diagram of the proposed optical monitoring scheme. A small fraction of the WDM signal, which is transmitted from a distant node, is extracted by an asymmetric optical power splitter for monitoring purposes. The optical signal then passes through an optical signal processor and is converted into an electrical signal by a photodetector. Electronic digital signal processing is used to separate the WDM channels. A unique reconstruction of the WDM channels in the electrical domain requires that the lost wavelength information (the conversion to the electrical domain makes the wavelength information lost) is compensated by a form of nonlinear optical signal processing. An example of an optical signal processor could be a wavelength-dependent attenuator (WDA), in which the optical length of one of the branches is adjustable [6], but in principle, any device that has a nonlinear relation between the wavelength and the output power can be used. As we will see later, it is not necessary to know the details of the nonlinear signal processing (e.g., the WDA). Digital signal processing (DSP) methods are used to analyze the measured photocurrents. In the next section, we show that a symmetric adaptive decorrelation (SAD) scheme, as described in [7] can be used to separate the WDM channels.

III. ADAPTIVE SIGNAL PROCESSING

As a starting point, we assume that each WDM channel has a nonreturn-to-zero (NRZ) data format with an ideal extinction ratio. This implies that only binary 1's contain a square optical pulse of amplitude $\sqrt{P_n(t)}$, where P_n is the time-dependent optical power in the n th channel. The input signal to the photodetector $E_p(t)$ is composed by a summation of the instantaneous discrete wavelength channels $E_n(t)$. The photocurrent

Manuscript received August 23, 2000; revised November 10, 2000. This work was supported in part by the Netherlands Organization for Scientific Research (NWO) under the "NRC Photonics" grant.

E. Tangdionga, N. Calabretta, and H. J. S. Dorren are with the Department of Telecommunications and Electromagnetism (TTE), Electro-Optical Communication, Eindhoven University of Technology, 5600 MB Eindhoven, The Netherlands.

P. C. W. Sommen is with the Department of Measurement and Control Systems (MBS), Signal Processing Systems, Eindhoven University of Technology, 5600 MB Eindhoven, The Netherlands.

Publisher Item Identifier S 1041-1135(01)01979-6.

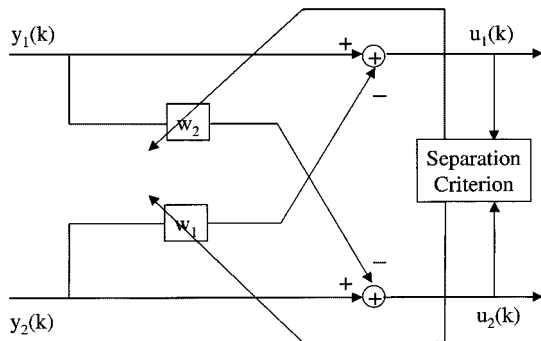

Fig. 2. Schematic of symmetric adaptive decorrelator for signal separation.

$y_p(t)$, which is the input for the signal processing, is proportional to the squared magnitude of the optical signals and it can be mathematically expressed as

$$y_p(t) = \mathcal{R} |E_p(t)|^2 + y_{th}(t) \quad (1)$$

where \mathcal{R} is the photodetector responsivity, and $E_p(t) = \sum_n E_n(t)$. The detector thermal noise $y_{th}(t)$ is modeled as an additive white Gaussian stochastic process with zero mean. It has to be remarked that the photodetector response is linear if the optical phase of the wavelength channels $E_n(t)$ is uniformly distributed with zero average (within the sampling time). We use for the signal processing in the electrical domain, a symmetric adaptive decorrelator as described in [7]. For reasons of clarity, we focus on the description for the case where two WDM channels are present. The derivation for an arbitrary number of channels can be performed in a similar manner. To describe the electronic digital signal processing, we use time discretization $t = t_0 + k\Delta t$, $k \in \{0, 1, \dots\}$ where t_0 is the initial sampling time and Δt is the sampling interval. We assume that the signals $y_1(k)$ and $y_2(k)$ can be written in the following forms:

$$\begin{aligned} y_1(k) &= s_1(k) + h_1 s_2(k) + y_{1,th}(k) \\ y_2(k) &= s_2(k) + h_2 s_1(k) + y_{2,th}(k). \end{aligned} \quad (2)$$

In (2), $s_j(k)$, $j \in \{1, 2\}$ represents the independent WDM channels. The attenuation coefficients of the WDA are given by h_j , which can be determined by processing the signals y_j according to the SAD, as presented in Fig. 2. The output signals u_j are given by

$$\begin{aligned} u_1(k) &= y_1(k) - w_1(k)y_2(k) \\ u_2(k) &= y_2(k) - w_2(k)y_1(k). \end{aligned} \quad (3)$$

The performance criterion is to minimize the cross-correlation of $u_1(k)$ and $u_2(k)$, i.e., $E[s_1(k)s_2(k-l)] = 0 \forall l$. $E[\cdot]$ indicates the estimated value. A stochastic gradient algorithm (type steepest descent) can be used to find the minimum. This leads to the following iteration series for the weight $w_j(k)$:

$$\begin{aligned} w_j^{(k+1)} &= w_j^{(k)} - \mu \frac{\delta f}{\delta w_j} \quad \text{with} \quad f = \sum_{l=0}^L [E_{u_1 u_2}^{(k)}(l)]^2 \\ E_{u_1 u_2}^{(k)}(l) &= \left(1 + w_1^{(k)} w_2^{(k)}\right) E_{y_1 y_2}^{(k)}(l) - w_1^{(k)} E_{y_2 y_2}^{(k)}(l) \\ &\quad - w_2^{(k)} E_{y_1 y_1}^{(k)}(l) \end{aligned} \quad (4)$$

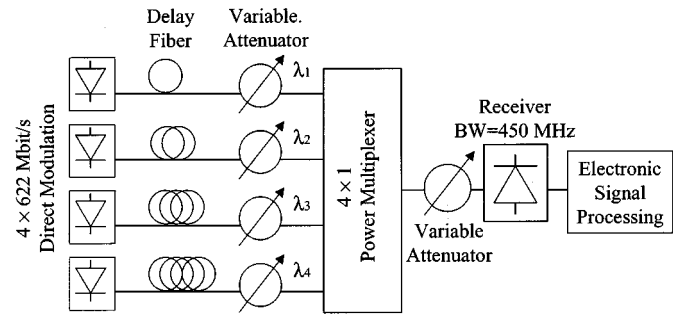

Fig. 3. Experimental setup.

where L is the number of photocurrent samples and μ is the adaptation constant ($0 < \mu < 1$). In our DSP, we have replaced the estimates of the cross-correlation $E_{u_1 u_2}^{(k)}$ with their instantaneous sampled value $u_1(k)u_2(k)$. Issues related to the convergence and stability of this algorithm are discussed in [7]. If (4) converges, the signals $u_1(k)$ and $u_2(k)$ in (3) are decorrelated. Adequate signal separation is obtained when the weights w_j in the adaptive scheme are equal to the WDA values, i.e., $w_j(\infty) = W_j = h_j$. The original signals $s_j(k)$ can then be reconstructed by an additional postprocessing step, which consists of applying a filter with a transfer function $1/[1 - W_1 W_2]$ on the output channels $u_j(k)$. By using a similar strategy as performed in [7], expressions for an arbitrary number of WDM channels can be obtained. Finally, we want to remark that the adaptive nature of the signal processing means that it is not necessary to know the details of the WDA since the attenuation coefficients are determined by the SAD. The fact that the WDM signals are recovered by inversion of (3) means that an accurate reconstruction of WDM channels requires that the inverse problem is sufficiently well posed.

IV. EXPERIMENT

Channel monitoring using the signal separation scheme is demonstrated in a four-channel WDM setup, as shown in Fig. 3. The channel wavelengths that are used are at 1551.0, 1554.2, 1557.4, and 1560.6 nm respectively. The laser sources are modulated directly by NRZ data from a pseudorandom binary sequence of length $2^{23} - 1$ at 622-Mb/s bit rate. With the channel spacing of 3.2 nm, the interchannel beating terms will lie outside the 450-MHz receiver bandwidth. Optical delay lines with different lengths are used to ensure that the channels are uncorrelated for a finite time span. The channels are coupled to the variable attenuators, which perform the WDA functions. The signals are detected by a p-i-n photodetector and further processed electronically to obtain the signal separation. As an initial step for the DSP, we set all weights to zero and use a 3-GHz bandwidth digital oscilloscope to obtain the sampled photocurrents. Each set of photocurrents is obtained by sequentially attenuating channels 1–4. Fig. 4 shows the four sampled photocurrents. These photocurrents are processed electronically and the results can be displayed on a monitor. As a typical result of the signal reconstruction, Fig. 5 shows the original channel 2 and the output of the DSP. Compared to the original signal, the signal separation scheme shows in general an excellent reconstruction result with a small deviation at 1's. The deviation is

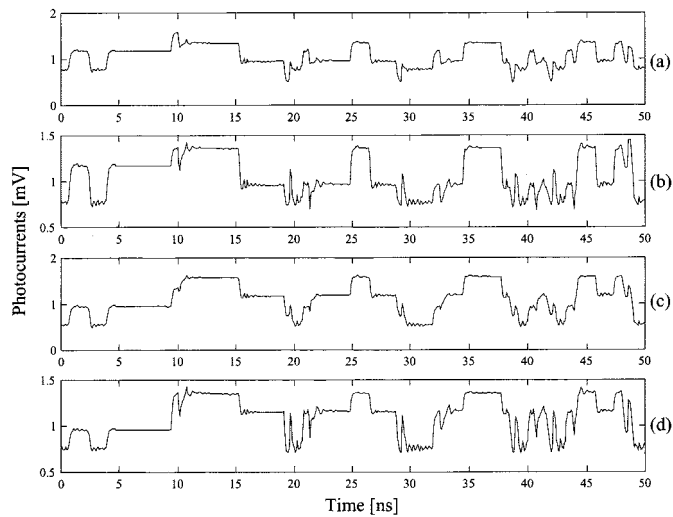

Fig. 4. Four-channel WDM photocurrents after 3-dB attenuation of (a) first, (b) second, (c) third, and (d) fourth channel.

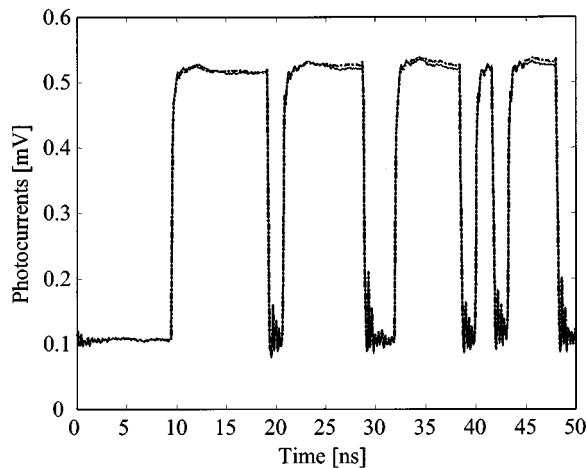

Fig. 5. Original (solid line) and reconstructed (dotted line) channel 2 using the blind signal separation and maximum data decorrelation.

merely caused by the variation in the signal levels due to the beating power of the thermal and shot noise to the signal, which is larger for 1's than that for 0's. The power level per channel before the attenuators was approximately -3 dBm and the extinction ratio was 15 dB. The optical signal-to-noise ratio was better than 30 dB (in a 0.1-nm resolution bandwidth). The performance of the signal reconstruction is largely dependent on the input signal levels to the photodetector. Lower input powers result in a large deviation of the signal reconstruction compared to the original signal. We observed that the power penalty is larger than approximately 2 dB [for bit error rate (BER) = 10^{-9}] in the receiver sensitivity if the power level decreases further than -22 dBm. The scheme apparently needs sufficient input powers mainly to suppress the influence of the noise. The absolute minimum input power for this setup is -25 dBm/channel before a significant deviation occurs. Given the receiver sensi-

tivity of -32 dBm for a BER = 10^{-9} , the minimum power can further be decreased when a combination of an optical preamplifier and a low-noise RF postdetection amplifier is employed. By doing so, an improved sensitivity of -28 dBm/channel is attained. Finally, the technique is evaluated to be polarization insensitive since the attenuators and photodetector were polarization insensitive.

V. CONCLUSION

We have proposed and demonstrated an optical monitoring technique that utilizes a signal separation scheme based on adaptive signal separation techniques. In order to reconstruct the signals uniquely, a form of nonlinear optical signal processing has to be implemented. The adaptive nature of the reconstruction method means that it is not necessary to know the details of the nonlinear optical signal processing. The method has been demonstrated for four channels at 622-Mb/s bit rate. If we assume that we have N channels, each containing L sample points, then for each iteration the computation of the weights is proportional to $L^2N!$ operations. In the experiment described in this letter, it was used that $N = 4$ and $L = 800$ (this corresponds to 30 samples/bit). In cases of more channels, it follows that the computation of the weights requires a rapidly increasing number of operations (due to the permutations that have to be taken over all the channels). On the other hand, monitoring of the channels is not required in the bit time, but rather on the timescale that the network is reconfigured. Since this algorithm is sensitive for amplitude fluctuations, we believe that this monitoring concept can also be applied to other amplitude-modulated data formats.

ACKNOWLEDGMENT

The authors would like to thank Dr. M. T. Hill for his valuable comments.

REFERENCES

- [1] T. Durhuus, B. Mikkelsen, C. Joergensen, S. L. Danielsen, and K. E. Stubkjaer, "All-optical wavelength conversion by semiconductor optical amplifiers," *J. Lightwave Technol.*, vol. 14, pp. 942–954, June 1996.
- [2] S. Schmid, S. Morasca, D. Scarano, and H. Herrmann, "High-performance integrated acousto-optic channel analyzer," in *Conf. Optical Fiber Communication OFC'97*, 1997, pp. 7–8.
- [3] L. E. Nelson, S. T. Cundiff, and C. R. Giles, "Optical monitoring using data correlation for WDM systems," *IEEE Photon. Technol. Lett.*, vol. 10, pp. 1030–1032, July 1998.
- [4] K. Otsuka, T. Maki, Y. Sampei, Y. Tachikawa, N. Fukushima, and T. Chikama, "A high performance optical spectrum monitor with high-speed measuring time for WDM optical networks," in *IOOC-ECO97, Inst. Elect. Eng. Conf.*, vol. 2, 1997, Paper 448, pp. 147–150.
- [5] Y. Hamazumi and M. Koga, "Transmission capacity of optical path overhead transfer scheme using pilot tones for optical path network," *J. Lightwave Technol.*, vol. 15, pp. 2197–2205, Dec. 1997.
- [6] M. P. H. van de Bergh, J. J. G. M. van der Tol, and H. J. S. Dorren, "A novel WDM monitoring method," *Photon. Netw. Commun.*, vol. 1, no. 4, pp. 323–329, 1999.
- [7] S. van Gerven and D. van Compernelle, "Signal separation by symmetric adaptive decorrelation: Stability, convergence, and uniqueness," *IEEE Trans. Signal Processing*, vol. 43, no. 7, pp. 1602–1612, 1995.