

2 x 10 Gbit/s WDM 1310-nm optical transmission over 63.5-km standard single-mode fiber using optical preamplifiers

Citation for published version (APA):

Waardt, de, H., Tiemeijer, L. F., & Verbeek, B. H. (1995). 2 x 10 Gbit/s WDM 1310-nm optical transmission over 63.5-km standard single-mode fiber using optical preamplifiers. *IEEE Photonics Technology Letters*, 7(1), 104-107. <https://doi.org/10.1109/68.363361>

DOI:

[10.1109/68.363361](https://doi.org/10.1109/68.363361)

Document status and date:

Published: 01/01/1995

Document Version:

Publisher's PDF, also known as Version of Record (includes final page, issue and volume numbers)

Please check the document version of this publication:

- A submitted manuscript is the version of the article upon submission and before peer-review. There can be important differences between the submitted version and the official published version of record. People interested in the research are advised to contact the author for the final version of the publication, or visit the DOI to the publisher's website.
- The final author version and the galley proof are versions of the publication after peer review.
- The final published version features the final layout of the paper including the volume, issue and page numbers.

[Link to publication](#)

General rights

Copyright and moral rights for the publications made accessible in the public portal are retained by the authors and/or other copyright owners and it is a condition of accessing publications that users recognise and abide by the legal requirements associated with these rights.

- Users may download and print one copy of any publication from the public portal for the purpose of private study or research.
- You may not further distribute the material or use it for any profit-making activity or commercial gain
- You may freely distribute the URL identifying the publication in the public portal.

If the publication is distributed under the terms of Article 25fa of the Dutch Copyright Act, indicated by the "Taverne" license above, please follow below link for the End User Agreement:

www.tue.nl/taverne

Take down policy

If you believe that this document breaches copyright please contact us at:

openaccess@tue.nl

providing details and we will investigate your claim.

2 × 10 Gbit/s WDM 1310-nm Optical Transmission over 63.5-km Standard Single-Mode Fiber Using Optical Preamplifiers

H. de Waardt, L. F. Tiemeijer, and B. H. Verbeek

Abstract—20 Gbit/s transmission over 63.5 km SMF at 1310 nm is reported by using two channel 10 Gbit/s wavelength (de)multiplexing ($\Delta\lambda = 1.5$ nm). Two 1310 nm SL-MQW semiconductor optical amplifiers are utilized for loss compensation and sensitivity improvement. For the 1310 nm wavelength domain, a record bitrate \times distance product of 1.27 Tbit/s.km has been obtained. Crosstalk penalties are identified, and the feasibility of an extension up to at least four, 10 Gbit/s channels is discussed.

I. INTRODUCTION

At present, 10 Gbit/s transmission systems are on the verge of commercial introduction and a growing demand emerges for 20 Gbit/s or more to meet the future requirements for broadband integrated services digital networks (B-ISDN). Many different approaches have shown very impressive results such as single channel 20 Gbit/s transmission employing external modulation [1], 20 Gbit/s PDM transmission [2], 160 Gbit/s WDM transmission [3] and 100 Gbit/s OTDM transmission [4]. All these experiments have been carried out in the 1550 nm wavelength domain and have been made possible by the availability of highly efficient 1550 nm fiber amplifiers (EDFA's). Very little attention has been paid to transmission in the 10–100 Gbit/s area, in the 1310 nm wavelength domain [5], [6], a natural choice for high bitrate transmission considering the near absence of dispersion-related problems at this wavelength. This restricted attention is mainly due to the lack of a suitable 1310 nm amplifier to compensate for losses introduced by the fiber attenuation and the (de)multiplex processes. Recently we have published 89 km transmission in the 1310 nm wavelength domain [7] applying low noise low polarization sensitivity strained layer MQW semiconductor optical amplifiers (SOA's) [8]. Using these amplifiers we have examined the potential of multichannel transmission of 10 Gbit/s channels in the 1310 nm wavelength domain. In this paper we demonstrate 20 Gbit/s WDM transmission over 63.5 km SMF employing the excellent properties of 1310 nm SL-MQW SOA's and investigate the limitations on the number of channels that can be accommodated.

Manuscript received June 16, 1994; revised September 2, 1994.

H. de Waardt is with the Royal PTT Nederland N.V., PTT Research, P.O. Box 421, 2260 AK Leidschendam, The Netherlands.

L. Tiemeijer and B. Verbeek are with Philips Optoelectronics Centre, Prof Holstlaan 4, 5656 AA Eindhoven, The Netherlands.

IEEE Log Number 9407093.

II. EXPERIMENTAL SETUP

As sources for the transmission experiments SL-MQW DFB laser diodes (CH A and CH B) are used which are directly modulated with 10 Gbit/s $2^7 - 1$ PRBS data patterns. Two channels are joined together by a 3 dB coupler as shown in Fig. 1. Bulk active layer DFB-LD's modulated with 3 Gbit/s $2^{15} - 1$ PRBS are employed as additional interfering channels during the crosstalk measurements (CH C and CH D). The receiver consists of two cascaded optical preamplifiers followed by a 50 Ohm optical front end [7]. Both SOA's are operated with 200 mA drive currents resulting in 25.7 dB to 27.5 dB fiber-coupled gain depending on the channel number and the polarization sensitivity is 2 dB for SOA1 and 1.4 dB for SOA2. A 0.2 nm fiber Fabry-Perot (Micron-Optics FFP-100, insertion loss 3 dB, FSR 20 nm) is used for channel selection and for reduction of the spontaneous-spontaneous beat noise. Our simple AC-coupled receiver restricts our system experiments to a relatively short 10 Gbit/s $2^7 - 1$ PRBS data pattern. However, sensitivity measurements with longer test patterns reveal a similar sensitivity degradation (0.7 dB for $2^{11} - 1$ PRBS) for the receiver alone and the preamplified receiver, indicating that the SOA cascade itself does not contribute to the observed sensitivity degradation. Transmitter parameters and receiver sensitivities are summarized in Table I.

III. CROSSTALK AND CHANNEL SPACING

In a wavelength multiplexed transmission system channel crosstalk results in signal degradation. In our experimental setup, penalties may arise from filter crosstalk and from crosstalk in the SOA cascade.

The filter crosstalk determines the minimum channel spacing. To determine the filter crosstalk penalty a measurement was carried out without the optical amplifiers. A transmitter channel spacing of 0.5 nm between the two 10 Gbit/s channels was established with equal source powers. This yields a channel rejection of 11.9 dB for CH A and 11.3 dB for CH B. In this situation a crosstalk penalty of 0.6 dB was measured for CH A and 0.4 dB for CH B. In order to further suppress the filter crosstalk the channel spacing of 0.5 nm was increased to 1.5 nm resulting in a channel rejection by the optical bandpass filter (OBPF) of well over 20 dB and no detectable crosstalk penalty. The output spectrum of the SOA cascade showing the two 10 Gbit/s channels ($\Delta\lambda = 1.5$ nm) is given in Fig. 2.

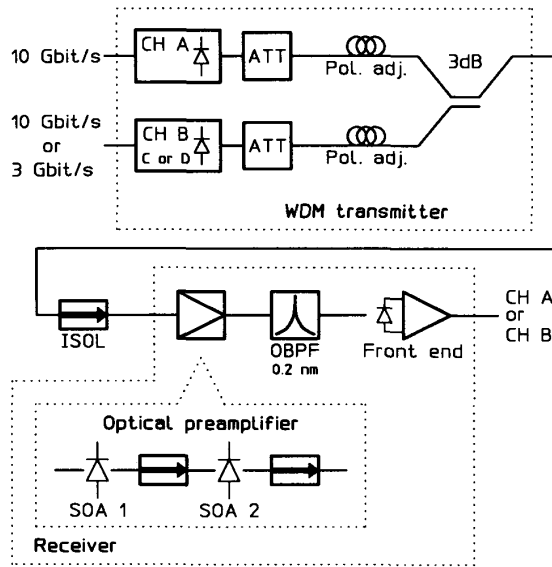

Fig. 1. Experimental set-up for the 2-channel 10 Gbit/s WDM system. CH A is modulated with a 10 Gbit/s data pattern, CH B is modulated with a time delayed inverted 10 Gbit/s data pattern. To simulate a true WDM system a 3 dB coupler can be inserted between the optical preamplifier and the optical bandpass filter.

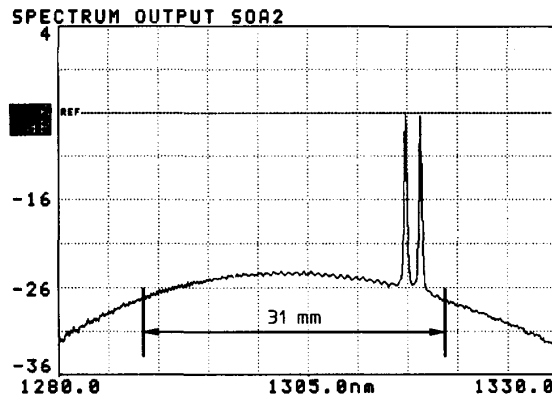

Fig. 2. Output spectrum of the SOA cascade. Channel $\Delta\lambda = 1.5$ nm, injected powers are -28 dBm for both channels.

The sensitivity degradation due to crosstalk in the SOA cascade was investigated by using the channels B, C, and D. The crosstalk introduced in the 10 Gbit/s channel A has been evaluated by monitoring the change in the bit error rate of this channel, starting with equal channel powers of -29 dBm and followed by a stepwise increase of the power of the interfering channel B, C, or D (Fig. 3). We observe that channels C and D which have a larger channel gain than channel B also introduce a larger crosstalk penalty, due to a combined influence of the increased channel gain and a reduced saturation output power at shorter wavelengths [8]. By inspecting the received bit frames of channel A we could identify the crosstalk predominantly as cross gain modulation. The influence of gain saturation in the SOA cascade on channel

TABLE I
TRANSMITTER PARAMETERS AND RECEIVER SENSITIVITIES.

	channel A	channel B	channel C	channel D
wavelength	1314.8 nm	1316.3 nm	1310.3 nm	1305.5 nm
chirped bandwidth (20 dB down)	0.45 nm	0.39 nm	0.33 nm	0.34 nm
extinction ratio	6:1	6:1	6:1	6:1
bitrate	10 Gbit/s	10 Gbit/s	3 Gbit/s	3 Gbit/s
channel gain	25.7 dB	25.7 dB	26.8 dB	27.5 dB
receiver sensitivity (BER = 10^{-9})	-13.5 dBm	-13.9 dBm	n.a.	n.a.
sensitivity with SOA cascade	-29.4 dBm	-29.9 dBm	n.a.	n.a.

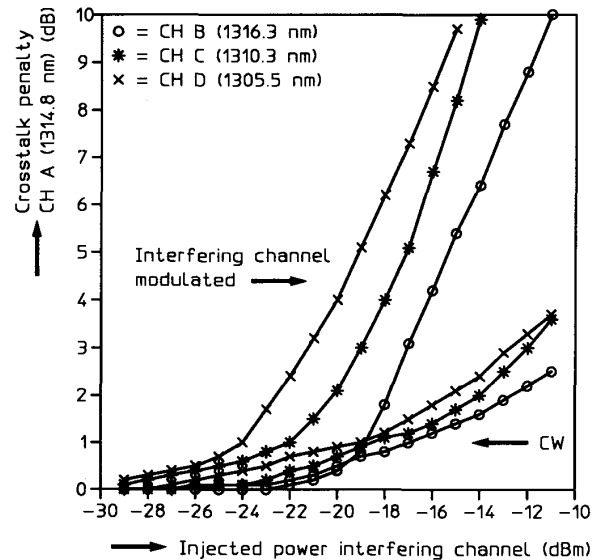

Fig. 3. Crosstalk penalty of CH A with an interfering channel (CH B, C, or D).

A is examined by injecting channel B, C, or D without modulation.

IV. 20 Gbit/s TRANSMISSION

A full WDM 20 Gbit/s transmission experiment has been realized by replacing the two attenuators (Fig. 1) by one attenuator after the 3 dB coupler (mux) and by inserting a second 3 dB coupler between the SOA cascade and the OBPF. By moving our filter/front-end combination from one coupler branch to the other, we can separately demultiplex and detect CH A and CH B, thereby realizing the full 20 Gbit/s system throughput. A 63.5 km SMF link with a total loss of 24 dB and a zero dispersion at 1305 nm terminated with a fiber optical isolator (1.3 dB loss) was inserted after the attenuator. The channel powers after the multiplexer are $+1$ dBm for CH A and $+0.5$ dBm for CH B. The receiver sensitivity at the input of the SOA cascade was first measured back-to-back after polarization optimization and yields -28.2 dBm for CH A and -28.4 dBm for CH B (Fig. 4). No evidence of channel crosstalk was found. After installation of the 63.5 km fiber link

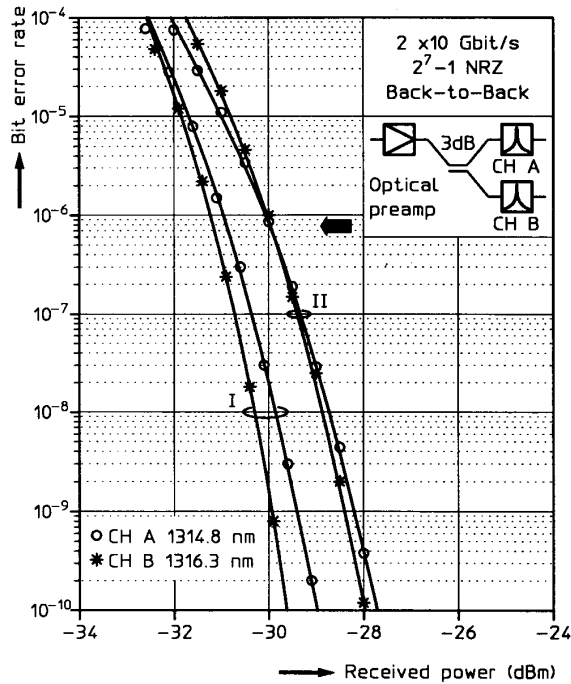

Fig. 4. BER-curves; the 2 channel 10 Gbit/s WDM measured Back-to-Back. BER curves (I) without 3 dB coupler, BER curves (II) with 3 dB coupler.

a sensitivity of -27.8 dBm (CH A) resp. -28.0 dBm (CH B) has been measured (Fig. 5). From the observed penalty of 0.4 dB for each channel we can assign 0.2 dB to dispersion as confirmed in separate single channel measurements over the 63.5 km link. The remaining penalty of 0.2 dB we attribute to crosstalk due to cross phase modulation [9] of the two copropagating channels over the 63.5 km fiber link. To confirm the feasibility of 20 Gbit/s transmission in a real practical environment, we replaced the attenuator and the 63.5 km link by 48 km field-installed standard SMF, embedded in ducts crossing an urban area, with a total span loss of 25 dB (including 12 connectors). A BER performance $<5 \times 10^{-11}$ could be maintained for both 10 Gbit/s channels.

V. DISCUSSION AND SUMMARY

Practical high bit rate, dense WDM systems do not only require optical amplifiers but also low loss wavelength division multiplexers and demultiplexers to avoid the need for excessive amplification. In our 20 Gbit/s transmission experiment the total demultiplex losses were 8 dB and 8.3 dB respectively which can be tolerated because of the large gain of the amplifier cascade. The inclusion of additional 3 dB couplers to increase the number of channels further is unrealistic because it will make the (de)multiplexing losses significantly higher. Therefore an extension with additional channels demands an advanced (de)multiplexer. A promising candidate is the polarization, independent compact 8-channel PHASAR demultiplexer/filter which has demonstrated on-chip losses of 4–5 dB/ch [10]. As a next step care should be taken that the crosstalk in the SOA is minimized. This crosstalk

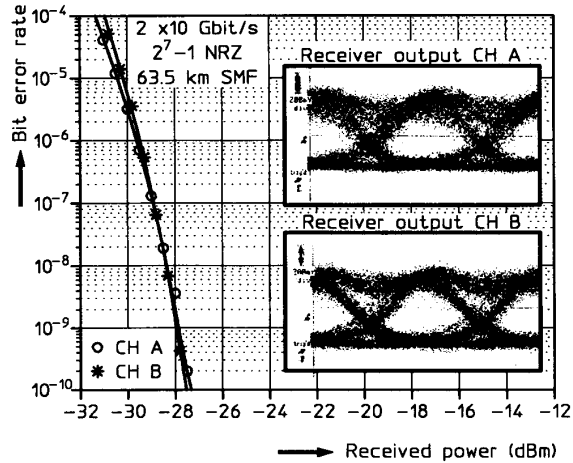

Fig. 5. BER curves (with 3 dB coupler) of the 2 channel 10Gbit/s WDM transmission experiment over 63.5 km SMF. The insets show the receiver eye diagrams of CH A ($P_i = -27.5$ dBm @ BER 2×10^{-10}) and of CH B ($P_i = -27.8$ dBm @ BER 4.2×10^{-10}).

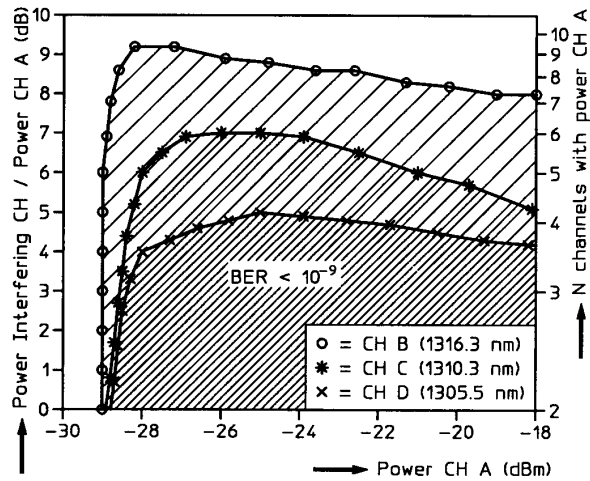

Fig. 6. Power ratio of the interfering channel and the signal channel versus the power of the signal channel. Right handscale: allowed number of channels to maintain BER $< 10^{-9}$ for three different channel spacings of the interfering channel with respect to main channel A. In the shaded area confined by respectively curve (*), (+) or (o), a BER $< 10^{-9}$ is obtained.

critically depends on the number of channels, their wavelength allocation and the channel input power. This is illustrated in Fig. 6 where we represent our crosstalk data (Fig. 3) as the ratio of the interfering power and the signal power versus the signal power. Taking for instance the curve (*) obtained for channel C (1310.3 nm) and neglecting a possible asymmetry in crosstalk between CH A and C, we can conclude that our preamplified receiver should be able to operate with 4 channels ($\Delta\lambda = 1.5$ nm) located between 1310 and 1315 nm simultaneously for an input power range of -28 dBm to -18 dBm per channel still maintaining a BER better than 10^{-9} per channel. It should be noted that Fig. 6 represents a worst case estimate because all interfering channels are in phase [11].

Regarding the results reported in [12] we demonstrate a better receiver sensitivity (-28 dBm versus -22 dBm) and a closer channel spacing, employing a less complicated receiver with only one SOA cascade. We do not need a separate demux filter in front of the SOA cascade due to the higher fiber-coupled saturation output powers ($> +9$ dBm) of our SL-MQW SOA's, resulting in lower crosstalk in our amplifier cascade.

In summary, a two channel, 10 Gbit/s WDM system at 1310 nm is described and analyzed. Crosstalk penalties are identified and a 20 Gbit/s transmission experiment is carried out over 63.5 km standard single mode fiber, yielding a record bitrate \times distance product of 1.27 Tbit/s.km for the 1310 nm wavelength domain. The feasibility for 20 Gbit/s WDM transmission over 48 km field installed fiber is also shown. Provided a low loss (de)multiplexer is used, an extension up to at least four 10-Gbit/s channels (aggregated capacity 40 Gbit/s) is considered feasible with this scheme.

REFERENCES

- [1] K. Hagimoto, T. Kataoka, and Y. Miyamoto, "Ultra-high-speed modulation technology for IM-DD systems," in *Proc. ECOC*, paper Mo C1.4, 1993.
- [2] F. Heismann, P. B. Hansen, S. K. Korotky, G. Raybon, J. J. Veselka, and M. S. Whalen, "Automatic polarisation demultiplexer for polarisation multiplexed transmission systems," *Electron. Lett.*, vol. 29, pp. 1965–1966, 1993.
- [3] A. R. Chraplyvy, A. H. Gnauck, R. W. Tkach, and R. M. Derosier, "160 Gb/s (8×20 Gb/s WDM) 300-km transmission with 50-km amplifier spacing and span-by-span dispersion reversal," in *Proc. OFC*, post deadline paper 19, 1994.
- [4] S. Kawanishi, T. Morioka, O. Kamatani, H. Takara, and M. Sarutari, "Time-division-multiplexed 100 Gbit/s, 200 km optical transmission experiment using PLL timing extraction and all-optical demultiplexing based on polarization insensitive four-wave-mixing," in *Proc. OFC*, post deadline paper 23, 1994.
- [5] A. H. Gnauck, R. M. Jopson, C. A. Burrus, S.-J. Wang, and N. K. Dutta, "16 Gbit/s transmission experiments using a directly modulated 1.3 μ m DFB laser," *IEEE Photon. Technol. Lett.*, vol. 1, pp. 337–339, 1989.
- [6] A. H. Gnauck, R. M. Jopson, J. D. Evankow, C. A. Burrus, S. J. Wang, N. K. Dutta, and H. M. Presby, "1 Tbit/s km transmission experiment at 16 Gbit/s using conventional fiber," *Electron. Lett.*, vol. 25, pp. 1695–1696, 1989.
- [7] H. de Waardt, L. F. Tiemeijer, and B. H. Verbeek, "89 km 10 Gbit/s 1310 nm repeaterless transmission experiments using direct laser modulation and two SL-MQW laser preamplifiers with low polarization sensitivity," *IEEE Photon. Technol. Lett.*, vol. 6, pp. 645–647, 1994.
- [8] L. F. Tiemeijer, P. J. A. Thijs, T. van Dongen, R. W. M. Slootweg, J. J. M. van der Heijden, J. J. M. Binsma, and M. P. C. M. Krijn, "Polarization Insensitive multiple quantum well laser amplifiers for the 1300 nm window," *Appl. Phys. Lett.*, vol. 62, pp. 826–828, 1993.
- [9] G. P. Agrawal, *Nonlinear Fiber-Optics*. New York: Academic Press, 1989, pp. 213–214.
- [10] B. H. Verbeek, A. A. M. Staring, E. J. Jansen, R. van Roijen, J. J. M. Binsma, T. van Dongen, M. R. van Amersfoort, C. van Dam, and M. K. Smit, "Large bandwidth polarisation independent and compact 8 channel PHASAR demultiplexer/filter," in *Proc. OFC*, 1994, post deadline paper 13.
- [11] L. Eskildsen, B. Mikkelsen, T. Durhuus, C. G. Joergensen, and K. Stubkjaer, "High-performance polarization independent semiconductor optical preamplifier," in *Proc. ECOC*, 1992, paper WeB8.6.
- [12] H. Nakano, S. Tsuji, S. Sasaki, K. Uomi, and K. Yamashita, "10 Gb/s, 4-channel wavelength division multiplexing fiber transmission using semiconductor optical amplifier modules," *IEEE J. Lightwave Technol.*, vol. 11, pp. 612–618, 1993.