

## ID39 LOW COST GREENHOUSE GAS SENSOR: GIDA-GEI

PABLO JUAN CAZALLA<sup>152</sup>, IVÁN IBÁÑEZ-FELIP<sup>126</sup>, ROSARIO VIDAL<sup>127</sup>

### ABSTRACT

This paper presents a low-cost compact Bluetooth sensor designed to periodically measure both in and out of water the concentration of greenhouse gases such as CO<sub>2</sub>, CH<sub>4</sub> and N<sub>2</sub>O. For this purpose, it has several sensors and modules connected and controlled by an Arduino Nano Every.

**Keywords** – Greenhouse, Low-Cost, Arduino, Underwater, Wireless

### LOW COST GREENHOUSE GAS SENSOR

GIDA-GEI is a low-cost compact Bluetooth sensor designed to periodically measure both in and out of water the concentration of greenhouse gases such as CO<sub>2</sub>, CH<sub>4</sub> and N<sub>2</sub>O. For this purpose, it has several sensors and modules connected and controlled by an Arduino Nano Every.

Once the system is turned on, it can be operated completely wirelessly from any device capable of running a Bluetooth serial. It does not require constant communication, only the connection is necessary to start and stop the value recording process.

All readings from the gas, pressure, temperature and global positioning sensors are transmitted via Bluetooth and recorded in the system's internal memory. The values can be tracked during the measurement process or downloaded after the end of the sampling period.

The system uses a 3000 mAh battery at 7.4V, which provides a life service of 10 hours with periodic recordings of all sensors every minute. However, the battery life can be extended depending on the application in which GIDA-GEI will be used, for example, underwater surveys where the GPS signal will not be recorded and constant Bluetooth communication is not feasible, the use of these modules can be turned off or reduced. Another option to extend the operating time of the sensor is to mount a larger battery, the system can support up to 12.6V batteries.

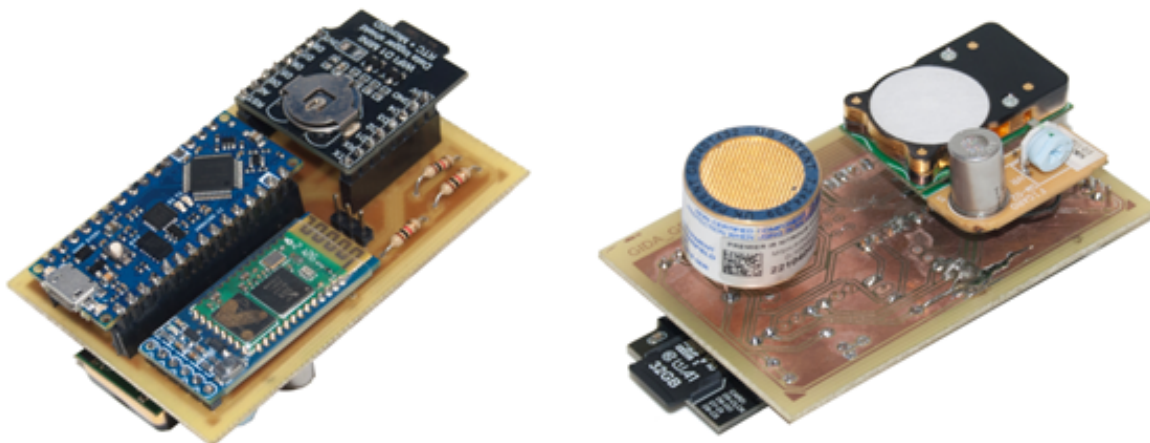

Figure 1: GIDA-GEI front and rear

### COMPONENTS

The GIDA-GEI system is composed of seven electronic modules connected to an Arduino Nano Every through a printed circuit board. Four of them are sensors to record different properties of the environment, while the other three are a RTC - Micro SD module (Wemos d1 mini data logger shield), in charge of keeping the date and storing the values recorded by the sensors, a Bluetooth module (HC-05) that allows wireless communication with the system and a GPS module (Air 530). With all these components GIDA-GEI dimensions are 8 x 4 x 3 cm, figure 1.

These are the sensors incorporated in GIDA-GEI:

- Figaro NGM2611-E13 is a pre-calibrated module for natural gas, in this case it is used to measure the CH<sub>4</sub> concentration.

The module uses TGS2611-E00 which incorporates a filter to eliminate the influence of interference gases. The measurement range of the sensor is 300 - 10000 ppm.

- COZIR-LP 500 is a low power NDIR CO<sub>2</sub> sensor that uses a solid-state LED optical technology. The measurement range of the sensor is 0 - 5000 ppm.
- DYNAMENT N2O is an infrared gas sensor for Nitrous Oxide gas over the range 0 - 1000 ppm.
- BPM 280 is a low power environmental sensor with thermometer and barometer.

Figure 2 shows the electrical connection of the modules with the Arduino.

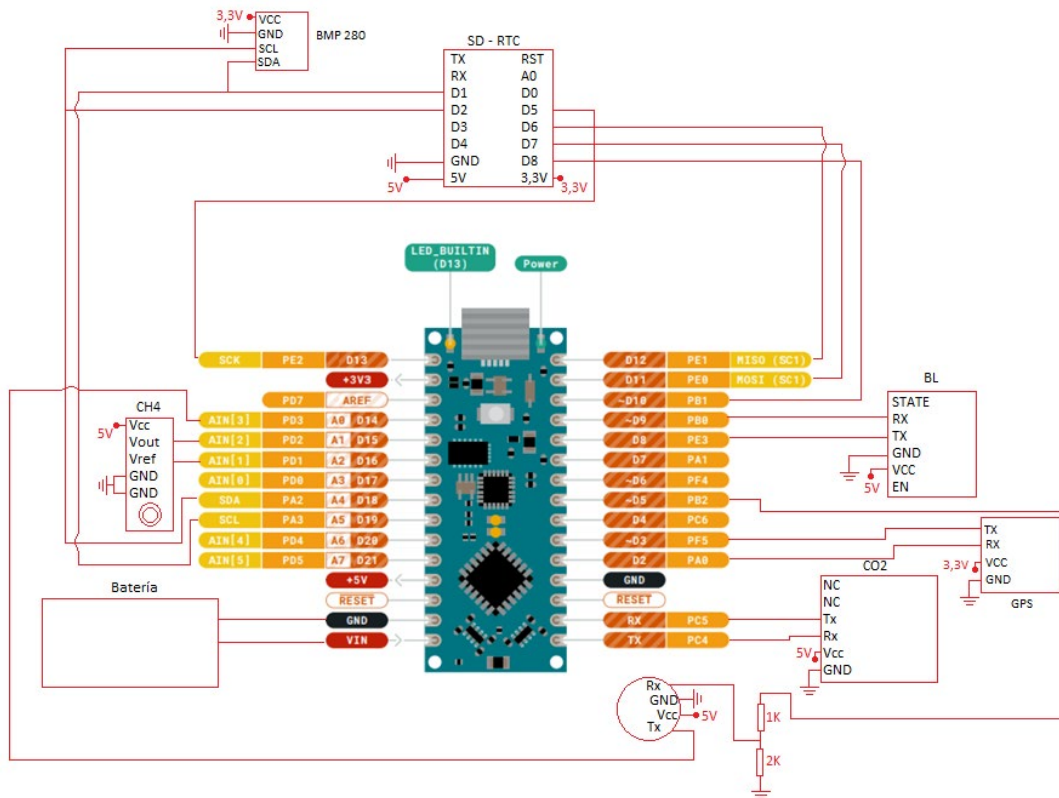

Figure 2: Electric scheme.

## CONCLUSIONS

GIDA-GEI is a prototype for the underwater measurement of greenhouse gases with great potential and very low cost. Future work will proceed to design the printed wiring board with the aim of reducing power consumption and dimensions, resulting in greater sampling autonomy.

## ACKNOWLEDGEMENT

This study forms part of the projects GEIROV, funded by Universitat Jaume I (UJI-B2021-61, and JELLYFISH-towards a sustainable precision aquaculture based on robotics, AI and low-cost sensors", included in the Aquaculture programme supported by MICINN with funding from European Union NextGenerationEU (PRTR-C17.11) and by Generalitat Valenciana (ThinkInAzul/2021/037, 2021-25).

## REFERENCES

- [1] David Bastviken, "The application of low-cost sensors in estimates of greenhouse gases", 2022.