

IDO7 MODULAR ACOUSTIC PLATFORM TO DEVELOP UNDERWATER BIDIRECTIONAL TAGS

G. BATET¹⁵, D. SARRIÀ¹⁶, M. NOGUERAS¹⁷, S. GOMARIZ¹⁸, J. DEL RIO¹⁹, I. MASMITJA²⁰

ABSTRACT

Miniaturised acoustic tags are key to conducting spatial behaviour studies on marine organisms (e.g., Norwegian Lobster). Nonetheless, the current technology has its limitations, specifically in acquiring high-resolution 3D movements. Engineering and developing new bidirectional acoustic tags will help improve the tracking and monitoring capabilities of the tagged species. To accomplish this milestone, a testbed needs to be established to validate and iterate over every tag's system. In this paper, the construction and capabilities of the first testbed's keystone tool are presented, and results from laboratory and field tests are discussed.

Keywords – Acoustic, Tags, Miniaturized, Tracking, Modularity.

INTRODUCTION

The development of a bidirectional acoustic tag implies a significant advancement in the field of fish and underwater species tracking and monitoring (e.g., Single base transceiver point range calculation), improving knowledge on the movements and spatial behaviours of these organisms, and thus helping better protect them from overfishing and another human-caused endangerment. This work aims to provide a highly modular and flexible platform to develop and implement new communication algorithms and protocols. Additionally, the platform has the capability to be connected and configured remotely, which allows us to connect it to the OBSEA underwater cabled observatory [1]. This study is a continuation of the first design and proof of concept presented previously [2].

THE PLATFORM

ELECTRONICS

This first encapsulated version consists of a basic functioning acoustic transmitter with reprogrammable firmware. This follows the process flow diagram shown in Fig.1, with three main blocks: (A) communications and power supply; (B) data processing and I/O; and (C) signal conditioning, amplification with a ceramic piezoelectric element tuned at 69 kHz.

COMMUNICATION PROTOCOL AND FUNCTIONING

For communications and power supply, a plug-and-play module has been designed based on the Lantronix Xport and a Direct Current (DC) power supply converter (DC to DC) isolated brick from TracoPower (model TEL 8-1210), switching the 9-18 V from the base station to the 3.3 V used in the tag's systems. A custom communication commands protocol over Ethernet has been implemented, this enables remote automation, control, and configuration with the LabVIEW application designed. Communication is divided into two phases. First, after powering on the system, the microcontroller expects, during 30 seconds, a go or no-go from the user to launch a tailor-made specific bootloader, for new firmware uploading. And if those 30 seconds have passed, the second phase starts with the routine program loading pre-set values and waits for a start command to begin a continuous 69 kHz emission. If necessary, the user can configure, via established commands, one of the other modes. The three modes available in the current firmware version are the following: (i) Continuous Emitting Mode at a given Frequency; (ii) Single Shot with a user-choice number of pulses (e.g., 50 pulses at 69 kHz with a 3/3 power level); and (iii) Pulse Position Modulation (PPM) with configurable pulses and stop time.

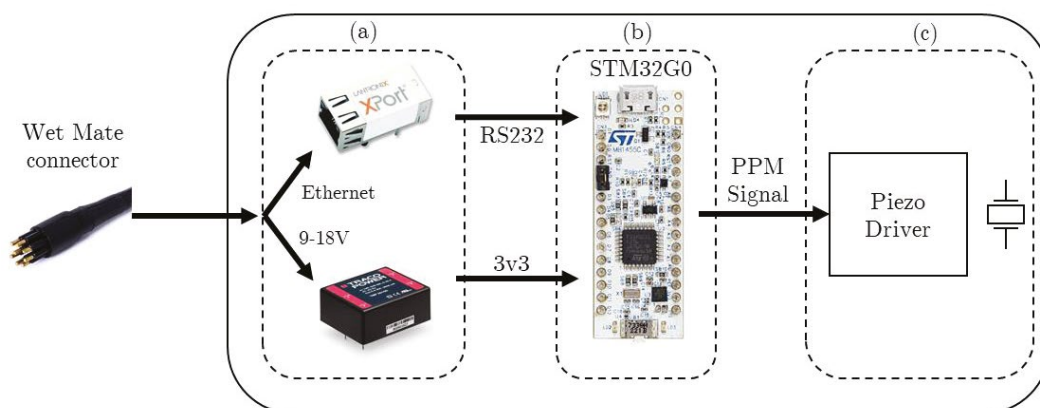

Fig.1. Systems' Process Flow Diagram. Three main blocks: A) Communication and Power, B) Microcontroller and C) Piezoelectric element and its driver

ASSEMBLY AND ENCAPSULATION

The board containing all three blocks has been assembled in a longitudinal stick form factor, this facilitates the encapsulating process. The electronics are connected to Subconn (McCartney Underwater Technology Group, Denmark) connector cable through a wire to an Ethernet connector (see Fig 2.). A rigid plastic material strip is added on both sides to reduce bending and torsion actions, an epoxy-based resin is poured in heat shrink tubing, serving as a mould and final outer mechanical protection. The piezoelectric element has its own encapsulation in a more rigid resin to enhance acoustic performance [3].

RESULTS

The tests done in the Laboratori d'Aplicacions Bioacústiques (LAB) research group pool facility from the Universitat Politècnica de Catalunya (UPC) revealed a transmitting power of 145 dB re 1 uPa at 3/3 power driver level. This test also validates the operability of having a bootloader to change the firmware. Field tests regarding range have been conducted in the OBSEA's region at 4 km off the Vilanova i la Geltrú coast. Up to 220 m the signal could be received by a commercial unit and 340 m with the installed Hydrophone

on the observatory at the seafloor (Fig. 2 Showing the last 255 m approximation to the hydrophone position).

CONCLUSIONS

This newly developed platform served as a baseline to test the first capabilities of the transmitting system composed of the piezoelectric and the driver, this is the first step in developing a major testbed system to test the designs and new systems to develop a bidirectional acoustic tag.

ACKNOWLEDGEMENTS

This work received financial support from different research projects of the Spanish Ministerio de Economía y Competitividad (SASES: RTI2018-095112-B-I00 and BITER: PID2020-114732RB-C32) and Generalitat de Catalunya's "SARTI-MAR" 2017 SGR 371. IM received financial support from the European Union's Horizon 2020 research and innovation programme under the Marie Skłodowska-Curie, grant agreement No 893089. GB received the support of Secretaria d'Universitats i Recerca del Departament d'Empresa i Coneixement de la Generalitat de Catalunya.

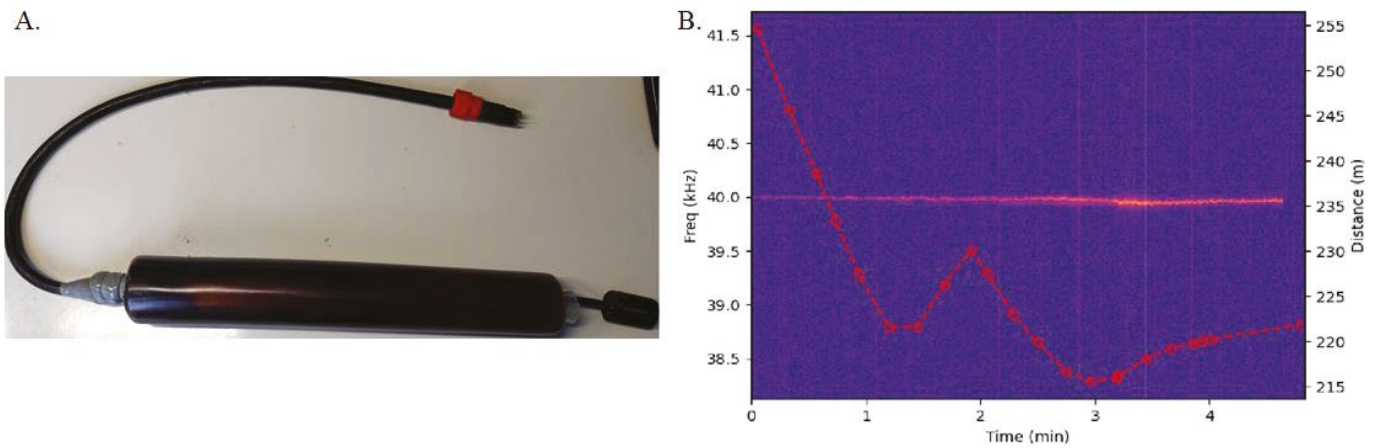

Fig 2. (A) The System fully encapsulated and (B) the first emitting test spectrogram with the varying range from the tag to the OBSEA's Hydrophone (Bjorge ASA NAXYS-Ethernet-02345)

REFERENCES

- [1] Del-Rio, J., Nogueras, M., Toma, D. M., Martinez, E., Artero-Delgado, C., Bghiel, I., ... & Lázaro, A. M. (2020). Obsea: a decadal balance for a cabled observatory deployment. *IEEE Access*, 8, 33163-33177.
- [2] Masmitja, I., Corregidor, D., López, J. M., Martinez, E., Navarro, J., & Gomariz, S. (2021, May). Miniaturised bidirectional acoustic tag to enhance marine animal tracking studies. In *2021 IEEE International Instrumentation and Measurement Technology Conference (I2MTC)* (pp. 1-6). IEEE.
- [3] Sarría, D. (2014). *Sistemas inalámbricos para la monitorización continua del comportamiento de especies marinas*.