



TITLE:

# Change of Oscillation Modes of Circular Underexpanded Jet by Impingement on a Small Plate

AUTHOR(S):

UMEDA, Yoshikuni; ISHII, Ryuji; POWELL, Alan

---

CITATION:

UMEDA, Yoshikuni ...[et al]. Change of Oscillation Modes of Circular Underexpanded Jet by Impingement on a Small Plate. *Memoirs of the Faculty of Engineering, Kyoto University* 1991, 53(4): 195-214

ISSUE DATE:

1991-10-31

URL:

<http://hdl.handle.net/2433/281444>

RIGHT:

# Change of Oscillation Modes of Circular Underexpanded Jet by Impingement on a Small Plate

By

Yoshikuni UMEDA\*, Ryuji ISHII\* and Alan POWELL\*\*

(Received June 20, 1991)

## Abstract

The frequency characteristics of the discrete tones generated by the impingement of a circular underexpanded jet on a small circular plate were studied experimentally. When the plate was moved along the jet axis at fixed pressure ratios, it was found that the frequencies could basically be divided into two groups. These groups belong to the categories of the impinging tones and the screech tones. Furthermore, it was observed that three types of frequency changes of the screech tones, (sawtooth, stepwise and intermittent ones), are realized periodically with the increasing nozzle-to-plate distance. Therefore, it is considered that the frequency change of the screech tone by the insertion of a small plate into the jet is associated with the self-sustained oscillation of the circular underexpanded free jet.

The most interesting phenomenon discovered is the stepwise change of the frequencies of discrete tones. The pressure ratio range of the stepwise change of the frequencies overlaps that for the helical oscillation mode of the free jet and that for the radiation of the strong hole tone.

## 1. Introduction

It has been well known that the acoustic emission from an underexpanded jet has a broad frequency band component as well as a few discrete ones in its spectrum. The latter component of the sound spectrum is generally called the screech tone. Powell<sup>1,2)</sup> suggested in conformity with his experimental studies that a feedback mechanism governs the emission of the screech tone. It consists of the downstream-convecting coherent vortical structures and upstream-propagating sound waves in the ambient.

He also reported that the frequencies for the circular jet exhibit several discontinuities at particular pressure ratios  $R$ .<sup>2)</sup> The discontinuities of the frequency characteristics of the screech tone radiated from a circular underexpanded jet suggest that the jet oscillates in different oscillation modes in the different

---

\* Department of Aeronautical Engineering, Kyoto University, Kyoto, Japan.

\*\* Department of Mechanical Engineering, Houston University, Texas, U.S.A.

pressure ratio ranges. Davies and Oldfield<sup>3)</sup> have found that five stages exist in the case of the circular underexpanded jet in the pressure ratio range of less than 6.0. They have established that the first four modes of oscillation are respectively toroidal, toroidal, sinuous and helical. The last one at the highest pressure ratio was established recently by spark schlieren photographs and an acoustic correlation technique to be sinuous, by Powell et al.<sup>4,5)</sup>.

Recently, Krothapalli<sup>6)</sup> performed a study of sound emitted from a rectangular underexpanded jet impinging on a flat plate placed at right angles to the jet axis, and found that a screech tone was radiated in addition to the impinging tone. Powell<sup>7)</sup> conducted a similar experiment in a circular jet impinging on circular plates, and found that when a circular underexpanded jet was impinged on a small or large circular plate placed concentrically with the nozzle exit, two types of impinging tones with different frequency characteristics were radiated. In the present experiments, the frequency characteristics of the discrete tones radiated from the underexpanded jet when the jet was impinged on a small circular plate were studied experimentally. Measurements of the frequency characteristics were carried out when the small plate was moved along the jet axis at eleven fixed pressure ratios of the jet.

From the measured frequency characteristics of the discrete tones, it was found that the discrete tones can basically be divided into two groups. One group is the screech tones, influenced somewhat by placing the plate in the jet. These frequencies are very close to the screech tones radiated from the underexpanded free jet. The other group is the impinging tones, which have higher frequencies than the screech tones and have only sawtooth frequency characteristics.

Moreover, it was found that the screech tones (lower frequency group) have three different types of frequency characteristic in the different pressure ratio ranges. Upon increasing the pressure ratio there appear sawtooth, stepwise and intermittent frequency characteristics. These three types of frequency changes are repeated periodically with an increasing nozzle-to-plate distance. The variety of the frequency characteristics of the screech tones gives us useful information about the basic behavior of the underexpanded free jet.

The stepwise frequency change is the most interesting phenomenon among the three types of frequency changes and will be discussed in detail. In the present experiment, several stepwise changes in the discrete tone frequencies are observed.

## 2. Experimental Apparatus

Brief descriptions of the experiments are presented in Refs. 4 and 5. In the present experiment, a supersonic jet of air was issued from a convergent circular nozzle with an internal diameter of  $d = 1.0$  cm and was impinged on a small plate with a diameter of  $D = 0.35$  cm. Two large plates with diameters of  $D = 1.00$  cm and  $2.00$  cm were also used in order to study the size effect of the plate. All the experiments were carried out in a simplified anechoic chamber.

First, the frequency characteristics of the screech tones radiated from the circular free jet were measured by a Bruel and Kjaer type-4135 condenser microphone. The microphone was placed in the plane of the nozzle at a distance of  $1.10$  m from the jet axis. The signal outputs from the microphone were recorded on a TEAC-R-410 data recorder and a spectral analysis was performed on a Fujitsu M760 computer in the Data Processing Center of Kyoto University.

Next, the frequency characteristics of the discrete tones radiated from the jet when a small plate was placed in the jet were measured. The schematic geometry of the configuration of the nozzle and the circular plate is shown in Fig. 1. The nozzle-to-plate distances  $h/d$  were changed from  $0.5$  to  $8.0$  at eleven fixed pressure ratios  $R$ .

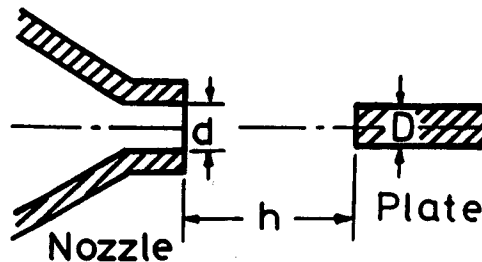


Fig. 1 Schematic view of configuration of nozzle and plate.

Then, the oscillation modes of the jet showing interesting frequency characteristics observed in this experiment were investigated by the same optical and acoustical techniques used in Refs. 3–5. In the optical observation, the spark schlieren photographs were taken by a conventional single pass schlieren system with a spark light source of a duration of about  $1 \mu\text{sec}$ . In the acoustical observation, the 3-dimensional structures of the wave fronts of strong sound waves emitted from the jet were discriminated by using two microphones. In this experiment, the phase differences of the sound waves propagating upstream were

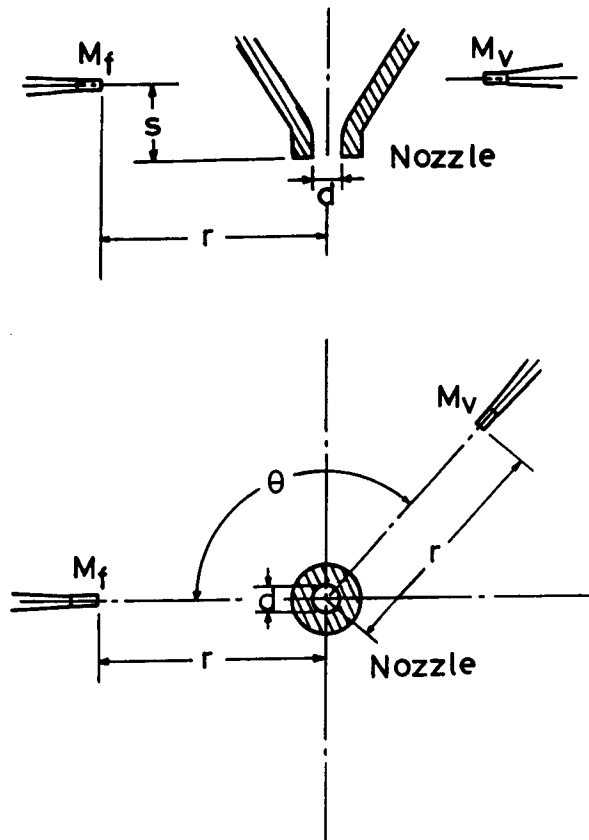


Fig. 2 Position of fixed and moveable microphones,  $M_f$  and  $M_v$ , respectively, relative to circular nozzle.

measured by the correlation technique. The configuration of the nozzle and two microphones are shown in Fig. 2. The first microphone,  $M_f$  (Bruel & Kjaer type-4135), was kept at a fixed position, while the second one,  $M_v$  (B & K type-4138), was rotated about the axis in 15 degree increments up to 180 degree relative to the first one.

### 3. Experimental Results

#### A. Frequency Characteristics

In Fig. 3, the frequencies  $f$  of the screech tones radiated from the round underexpanded jet are plotted against the pressure ratio  $R$ . This figure is the same as Fig. 1 in Ref. 4 except for the notations (a)-(k). In Figs. 4(a)-(k), the frequencies  $f$  of the discrete tones radiated when the supersonic jet was impinged

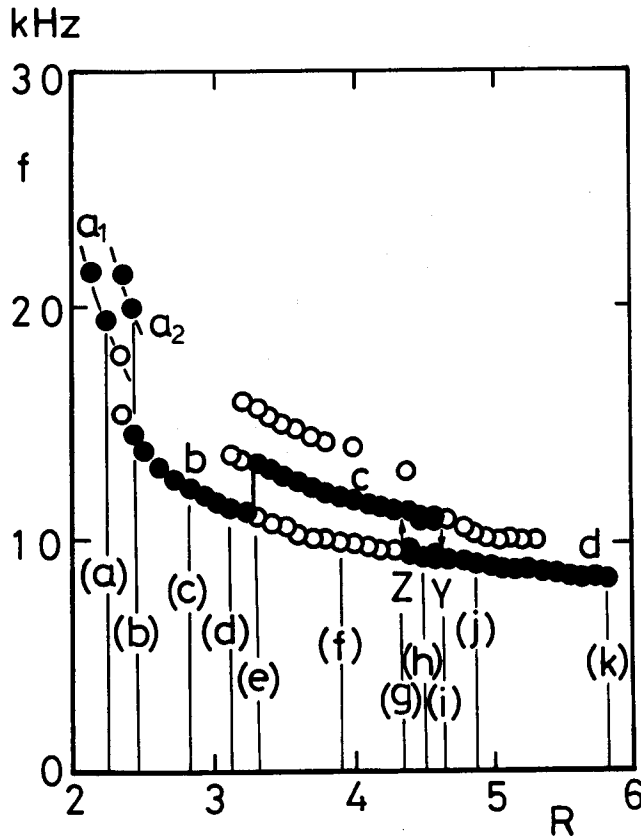
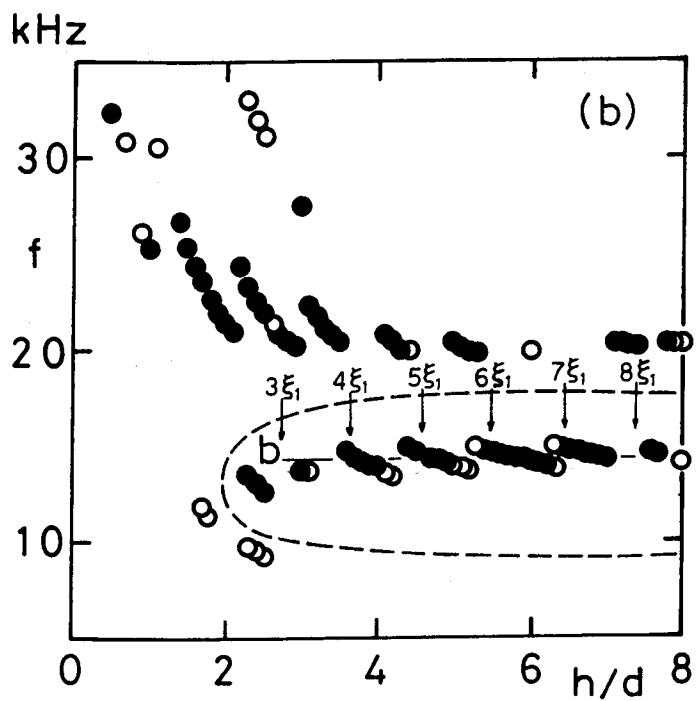
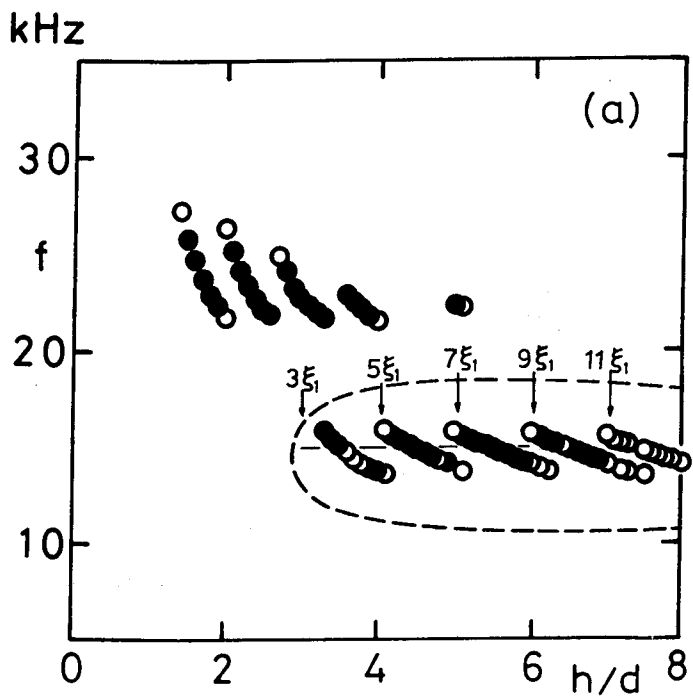
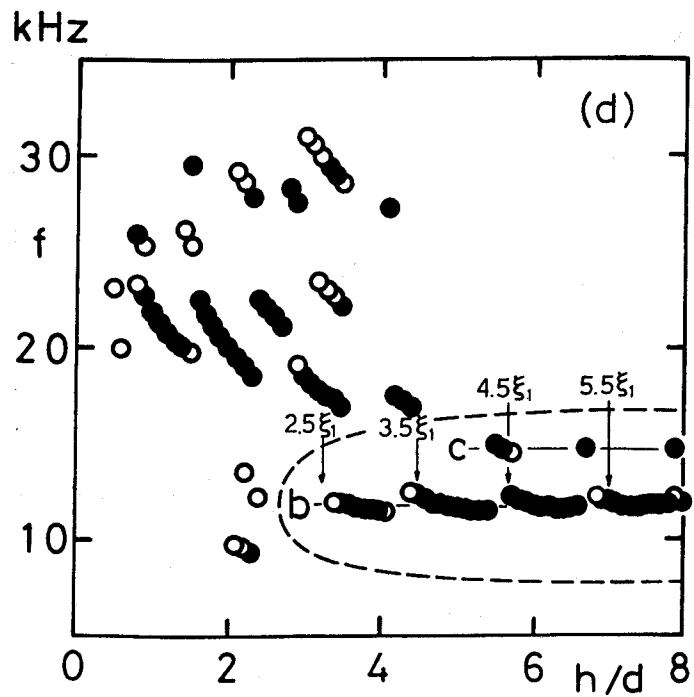
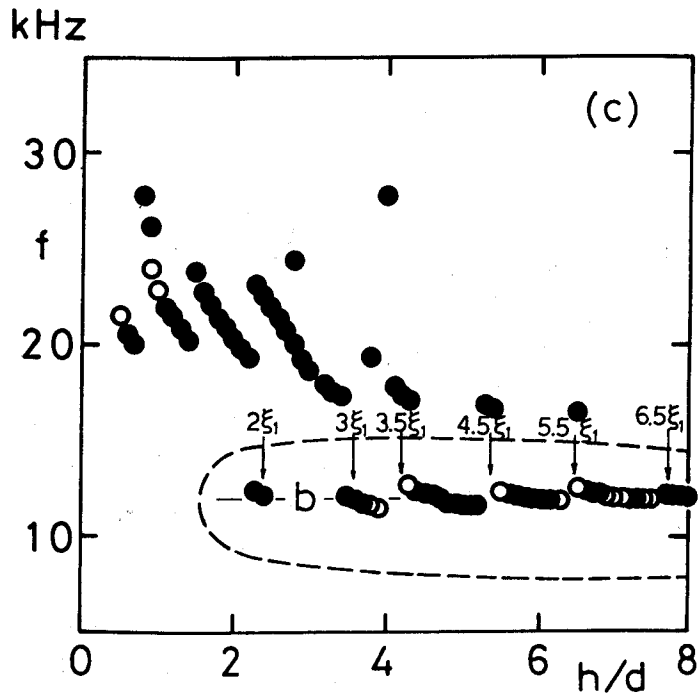


Fig. 3 Frequencies of screech tones at fixed microphone for circular underexpanded jet as a function of pressure ratio. Black data points indicate dominant tones, white data points indicate secondary tones.

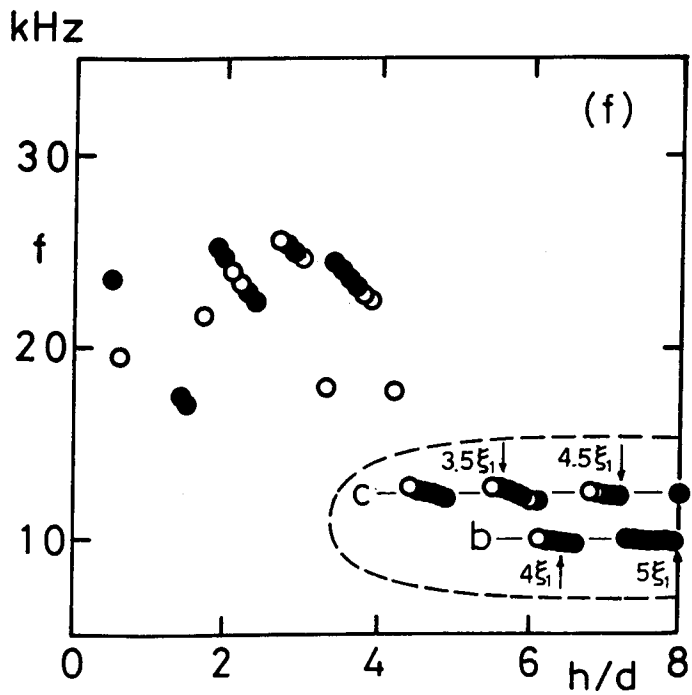
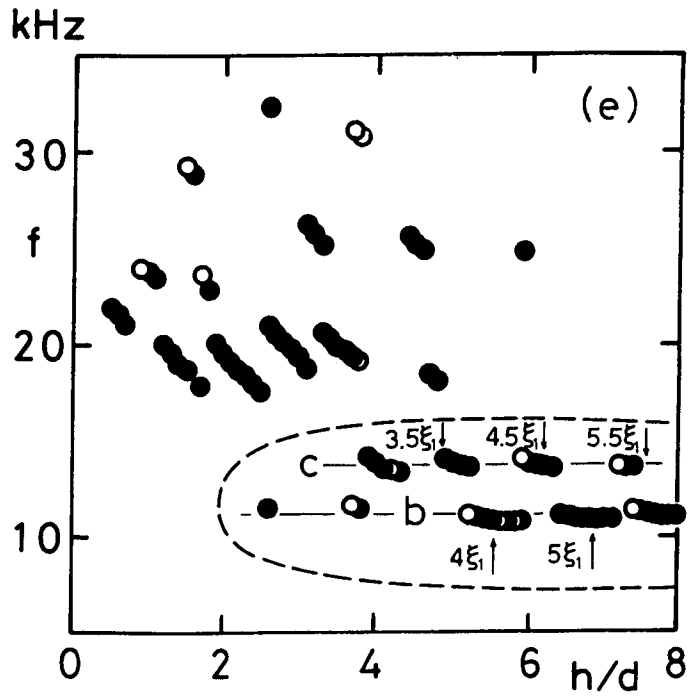
on a small circular plate are plotted against the nozzle-to-plate distance  $h/d$  at eleven fixed pressure ratios of the jet. The sub numbers (a)–(k) in Fig. 4 correspond to those denoted in Fig. 3. The pressure ratios  $R$  used in this study were 2.26, 2.45, 2.93, 3.12, 3.32, 3.90, 4.29, 4.48, 4.68, 4.87 and 5.84. These values of the pressure ratios correspond to those in the case of the free jet for stages ‘ $a_1$ ’, ‘ $a_2$ ’, ‘ $b$ ’, ‘ $b$ ’, the transition between stages ‘ $b$ ’ and ‘ $c$ ’, stage ‘ $c$ ’, the border of the lowest pressure ratio of the hysteresis region, the hysteresis region between stages ‘ $c$ ’ and ‘ $d$ ’, the border of the highest pressure ratio of the hysteresis region, and stages ‘ $d$ ’ and ‘ $d$ ’, respectively.

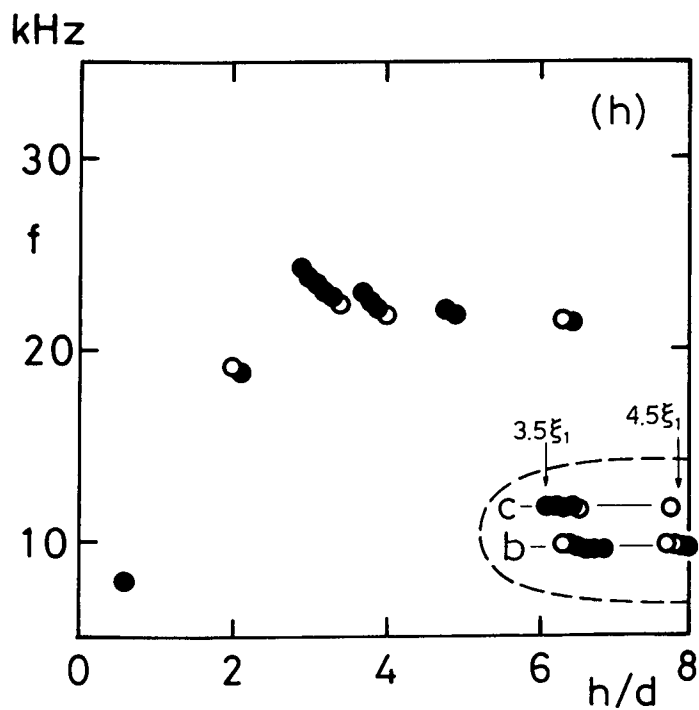
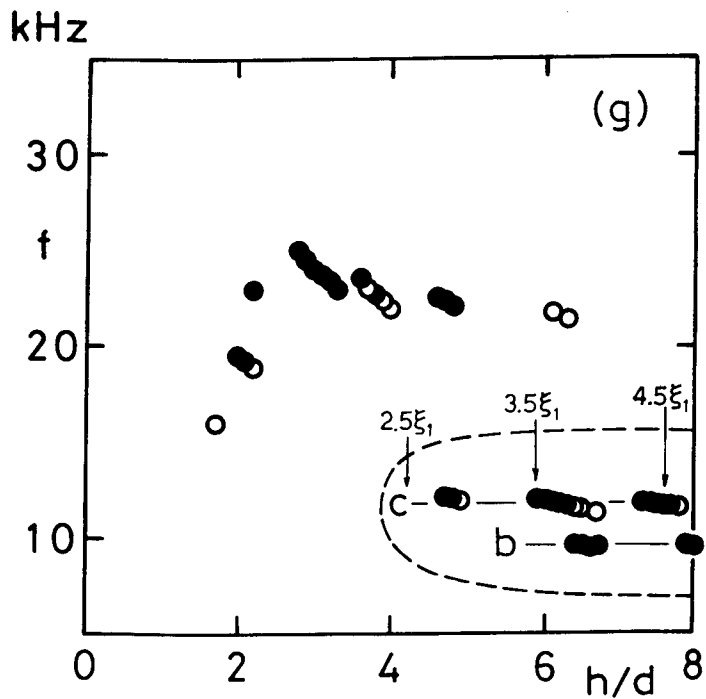
In Figs. 3 and 4, data points denoted by the black circles indicate the dominant tone, the level exceeding the local broad band noise by at least 10dB (usually

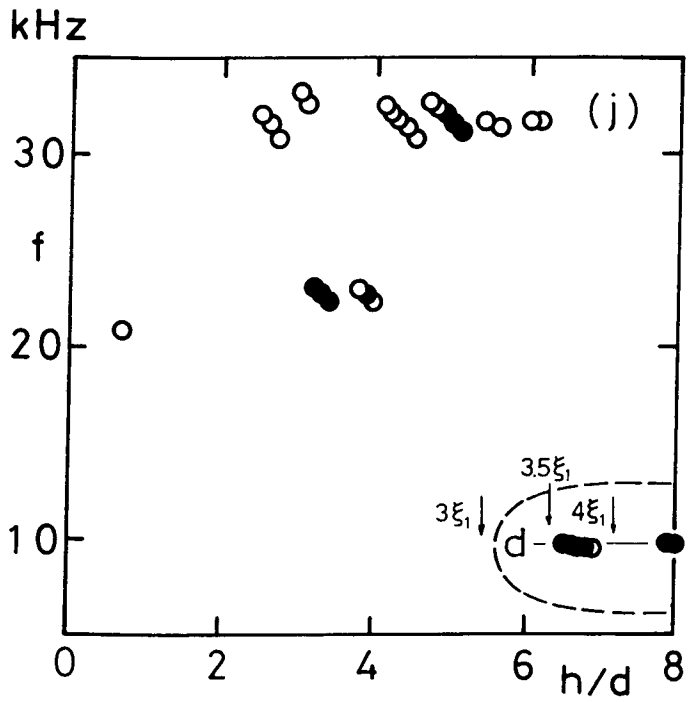
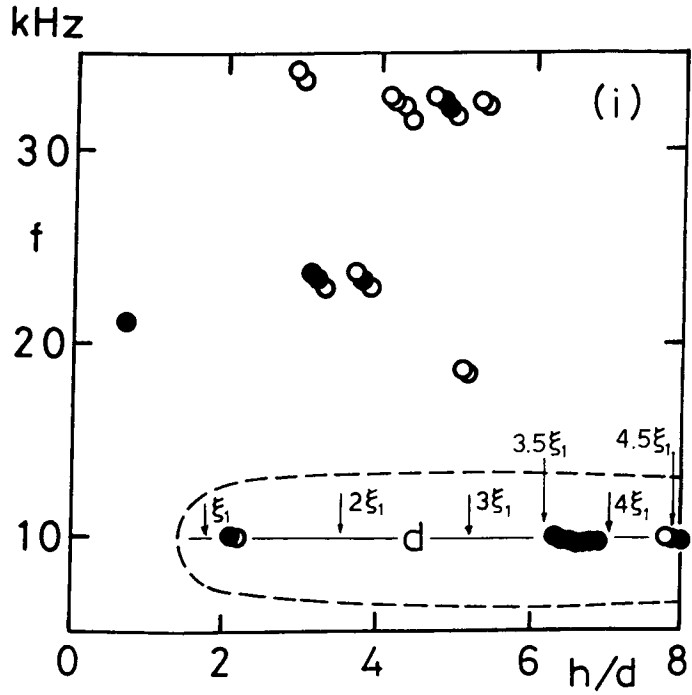












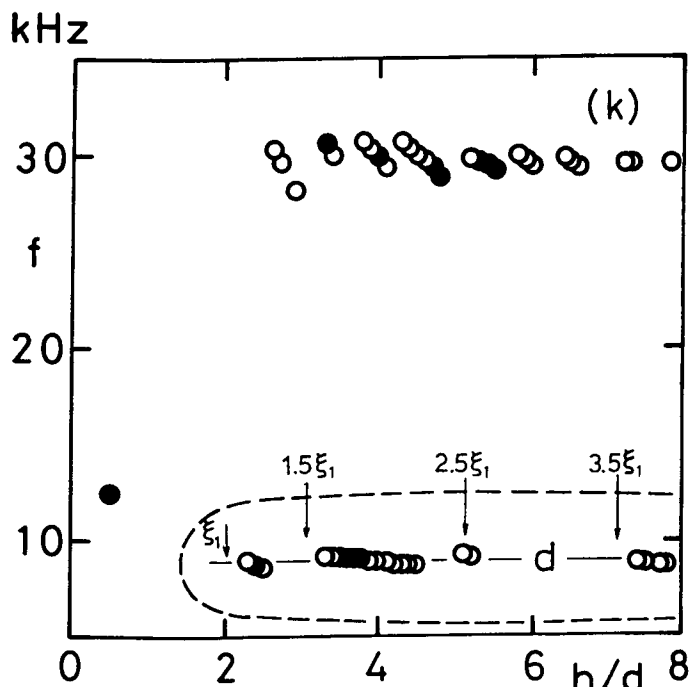


Fig. 4 Frequencies of discrete tone for small plate ( $D/d = 0.35$ ) as a function of nozzle-to-plate distance: (a)  $R = 2.26$ , (b)  $R = 2.45$ , (c)  $R = 2.93$ , (d)  $R = 3.12$ , (e)  $R = 3.32$ , (f)  $R = 3.90$ , (g)  $R = 4.29$ , (h)  $R = 4.48$ , (i)  $R = 4.68$ , (j)  $R = 4.87$ , (k)  $R = 5.84$ .

much more, typically 35 dB) and the data points marked by open circles denote secondary tones exceeding the broad band noise by 5–10 dB. In these figures, only the frequencies of the fundamental frequency component of the discrete tones are plotted.

We can see from Fig. 4 that there are two groups in the frequency characteristics. Namely, they are a higher and a lower frequency group. As the frequencies of the discrete tones belonging to the lower frequency group are very close to the screech tones, it is considered that these tones are essentially the same as the screech tones. In Figs. 4(a)–4(k),  $\xi_1$  denotes the first shock cell space of the circular free jet. The values of  $\xi_1$  vary with the pressure ratio  $R$  of the jet. The relationship between  $\xi_1$  and  $R$  is presented in Ref. 9. From these figures, it is obvious that the changes in screech frequency are repeated periodically with increasing nozzle-to-plate distance. The travelling length of the plate for one periodic change is almost the same as the first shock cell space of the free jet for the same pressure ratio except for one case which belongs to stage 'a<sub>1</sub>' of the free jet, the lowest pressure ratio of the jet studied in this experiment. In this

exceptional case, the travelling length for one periodic change is almost the same as twice the first shock cell space. From these facts, we supposed that the frequency characteristics of the lower frequency group would reflect the basic behavior of the underexpanded free jet and our attention was focussed on only these frequency characteristics. The lower frequency group are enclosed by dotted lines in these figures. The other discrete frequencies are the impinging tones.

In the following, we will observe closely the frequency characteristics of the lower frequency group. From Figs. 4(a) and 4(b) ( $R = 2.26$  and  $2.45$ ), it can be seen that both frequency characteristics at the pressure ratios  $R = 2.26$  and  $2.45$  are very similar to each other except that the former frequencies are slightly higher than the latter ones. Although the average frequency at pressure ratio  $R = 2.26$  is about 15 kHz from Fig. 4(a), we could not find a similar frequency of screech tone at the same pressure ratio in Fig. 3. On the other hand, the average frequency at pressure ratio  $R = 2.45$  (see Fig. 4(b)) is nearly equal to the screech tone frequency of stage 'b' at the same pressure ratio. In Fig. 4(c) ( $R = 2.93$ ), the sawtooth frequency characteristic is still observed. But the gradient of the sawtooth characteristic is less than those in Figs. 4(a) and 4(b). The average frequency in this case is also almost equal to the screech tone frequency of stage 'b'. It can be observed in Fig. 4(d) ( $R = 3.12$ ) that the lower frequency group is further divided into two groups. The discrete frequencies belonging to these two groups are generated alternately with increasing nozzle-to-plate distance. The average frequencies of the two groups correspond to those of stages 'b' and 'c' of the screech tone, respectively. The stepwise frequency characteristics become clearer in the results at the pressure ratios  $R = 3.32$  and  $3.90$  as shown in Figs. 4(e) and 4(f). In Figs. 4(g) and 4(h) ( $R = 4.29$  and  $4.48$ ), the stepwise frequency characteristics are not so clear. At the higher pressure ratio of the jet ( $R = 4.69$  and  $4.87$ ), the stepwise frequency characteristics are changed to intermittent ones because of the lack of one frequency component which belongs to the helical oscillation mode as shown in Figs. 4(i) and 4(j). The average frequencies in these cases are also almost equal to the screech tone frequencies of stage 'd' corresponding to each pressure ratio. In Fig. 4(k) ( $R = 5.84$ ), the intermittent frequency characteristics can be seen for a wide range of the nozzle-to-plate distance. The average frequency in this case is nearly equal to the screech tone frequency of stage 'd' for the same pressure ratio.

From the above frequency characteristics of the discrete tones, it was found that the screech tones show three different types of frequency characteristic, depending on their pressure ratio range when the pressure ratio is fixed and the small plate is moved along the jet axis. There appear sawtooth, stepwise and

intermittent frequency characteristics with an increase in the pressure ratio. Stepwise and intermittent frequency changes of the discrete tones have not been reported so far. It was also found from the present experimental results that the pressure ratio ranges for the occurrence of these three types of frequency characteristics are about  $R < 2.9$ ,  $3.1 < R < 4.5$ , and  $4.6 < R$ , respectively.

Two frequencies for stepwise frequency change coincide with those of the dominant and secondary screech tones radiated from the free jet at the same pressure ratios. For example, the frequencies of the discrete tones denoted by letters *b* and *c* in Fig. 4(e) are almost equal to the screech tone frequencies of the corresponding stages ('*b*' and '*c*') at the same pressure ratio, as shown in Fig. 3. According to the results presented in Refs. 3 and 4, it can be predicted that the higher and the lower frequency tones in the stepwise frequency characteristics correspond to the helical and sinuous oscillation modes of the jet, respectively. Therefore, in the following, two oscillation modes of the jet for the stepwise frequency change will be discriminated by the optical and acoustical methods.

#### B. Optical Observation

For the sake of the discrimination of the oscillation modes of the jets, the flow fields of the supersonic jet as well as the near sound field were visualized by the spark schlieren technique. Figure 5(a) shows a photograph of the free jet at the pressure ratio  $R = 3.90$ . Figures 5(b) and 5(c) show photographs of the jets at the same pressure ratio where the small circular plate is placed at the distances  $h/d = 5.8$  and  $6.3$ , respectively. All the pictures presented in Fig. 5 show that the jets oscillate asymmetrically. In Refs. 4 and 5, it was clarified that the free jet operating at the pressure ratio  $R = 3.90$  oscillates in helical mode. Although, in general, the asymmetric oscillation modes of the jet as shown in Figs. 5(b) and 5(c) can further be divided into helical and sinuous oscillation modes, it cannot be discriminated from the photographs alone which tone belongs to helical or sinuous oscillation mode.

#### C. Acoustical Observation

In order to discriminate the oscillation modes of these tones, the 3-dimensional structures of sound wave fronts were investigated experimentally. This was performed by using the same technique as that presented in Refs. 3–5. The phase differences of the strong sound wave fronts radiated from the jets were measured by using two microphones in this experiment and the results are shown in Fig. 6. Figures 6(a) and 6(b) show the results at the pressure ratio  $R = 3.90$  and the distances  $h/d = 5.8$  and  $6.3$ , respectively. According to the criteria presented in

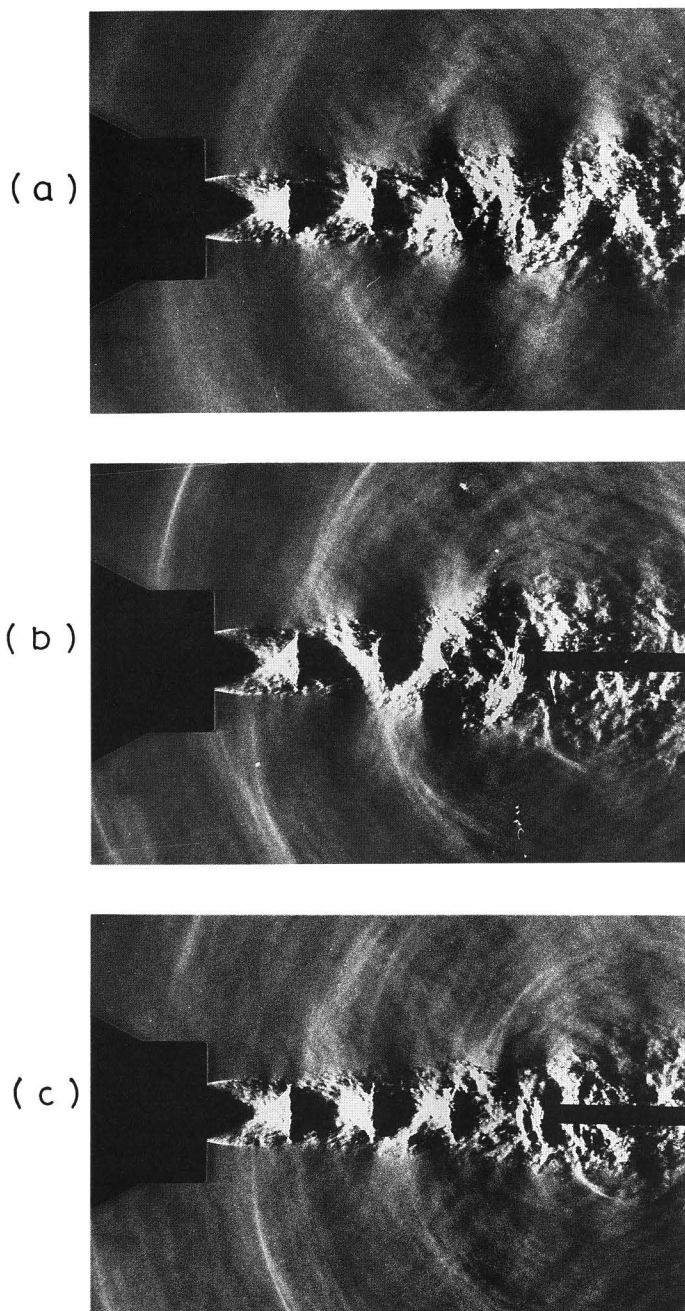


Fig. 5 Schlieren photographs of underexpanded jet for pressure ratio  $R = 3.90$ : (a) Free jet, (b)  $h/d = 5.8$ , (c)  $h/d = 6.3$ .

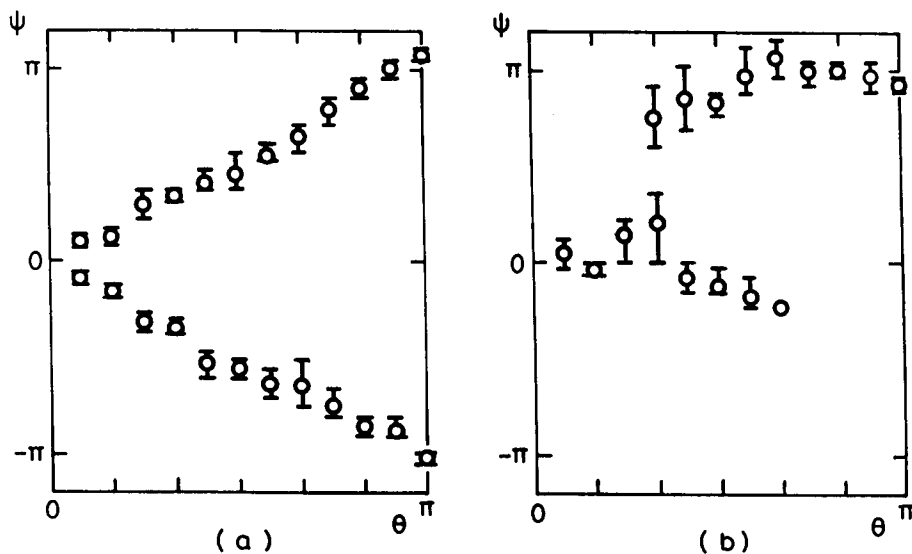


Fig. 6 Variation in phase angle  $\psi$  at moveable and fixed microphones, separated by angle  $\theta$  for situations of Figs. 5(b) and 5(c): (a)  $h/d = 5.8$ , (b)  $h/d = 6.3$ .

Refs. 3–5, these results demonstrate that the jet oscillation modes for  $h/d = 5.8$  and 6.3 are helical and sinuous, respectively. These results coincide with ones predicted in the last part of Sec. 3A. So, we suppose that the oscillation modes at the other pressure ratio ranges coincide with those of the free jet. In the present experiment, we also found that the helical oscillation mode behaves the same as those presented in Refs. 3–5.

#### 4. Discussion

The frequency characteristics of the discrete tones radiated from an underexpanded jet when the jet was impinged on a small circular plate were studied in the present experiment. From the frequency characteristics of the discrete tones radiated when the plate was moved along the jet axis at eleven fixed pressure ratios of the jet, it was found that the discrete frequency components can basically be divided into two groups. They are impinging tones (higher frequency group) and screech tones affected by placing a small plate in the jet (lower frequency group). Two other examples of the radiation of the screech tones are presented in Refs. 8–10.

Further, it was found that three different types of frequency characteristic of screech tone appear, depending on the pressure ratio range; they are sawtooth, stepwise and intermittent. In these three types of frequency change of screech



tone, the frequency changes are repeated periodically with increasing nozzle-to-plate distance. The travelling length of the plate for one periodic change is almost the same as the first shock cell space of the free jet at the same pressure ratio, except for one case corresponding to stage 'a<sub>1</sub>' in the case of the free jet. In this exceptional case, the travelling length of the plate for one periodic change is almost the same as twice the first shock cell space of the free jet. It was also found from this experimental study that the stepwise change of frequency occurs in the pressure ratio range  $3.1 < R < 4.5$  and in the distance range  $h/d > 2.5$ . This pressure ratio range just overlaps that for the helical oscillation mode of the underexpanded free jet<sup>4,5)</sup>, and that for the radiation of the strong hole tone.<sup>8)</sup> In the radiation of the strong hole tone, the helical oscillation mode of the free jet is converted into an axisymmetric one. Very intense hole tones are radiated when the jet pressure ratio is in the range  $3.3 < R < 4.5$  and the distance  $h/\xi_1$  from nozzle to plate with a hole is nearly equal to 2.0. On the contrary, in the present case, the presence of a small plate changes a helical oscillation mode into a sinuous one and vice versa, depending on the position of the small plate for  $h/\xi_1 > 3.0$ .

Two frequencies of the discrete tones, showing stepwise characteristics, are almost equal to the dominant and secondary screech tone frequencies radiated from the free jet at the same pressure ratio. The experimental results obtained in this investigation clearly show that the higher and the lower frequency tones of the stepwise frequency curve correspond to the helical and the sinuous modes of oscillation, respectively. In the case of free jets, the radiation of the dominant helical and the secondary sinuous oscillation modes of sound waves were observed in the pressure ratio range  $3.3 < R < 4.5$ . When a small plate was placed in the jet, however, the dominant helical and sinuous oscillation modes of sounds appeared alternately with the increasing of the nozzle-to-plate distance. This may suggest that the insertion of a small plate into the jet at some particular distances downstream from the nozzle exit will cause some effects to the feedback loop for the generation of the screech tones. Thus, the jet oscillation modes will change depending on the position of the plate. From the data shown in Figs. 4(e) and 4(f), it was found that the 'b' mode of oscillation dominates when the small plate is placed at the positions around  $4\xi_1$  and  $5\xi_1$ ; on the other hand, the 'c' oscillation mode dominates when the plate is placed at the positions near  $3.5\xi_1$  and  $4.5\xi_1$ .

Further, the intermittent frequency characteristics were observed for the pressure ratio range  $R > 4.6$ . In this pressure ratio range, only the sinuous oscillation mode was observed with an increase in the nozzle-to-plate distance. Since the secondary tones of the helical oscillation mode were detected for the pressure ratio range  $4.6 < R < 5.3$  of the frequency characteristics of the screech

tone as shown in Fig. 3, we expected that the stepwise change of the discrete frequency might also be observed, at least for the pressure ratios  $R = 4.68$  and  $4.87$ . But, such a stepwise change in the discrete frequency could not be detected in the pressure ratio range (see Figs. 4(i) and 4(j)). Instead, only the sinuous oscillation mode was observed. This can also be confirmed from the photographs in Fig. 7. Figure 7(a) shows the jet for  $R = 4.87$  and  $h/d = 6.8$ . Figure 7(b) shows the jet for  $R = 4.87$  and  $h/d = 7.4$ . From the photograph in Fig. 7(a), it can be observed that a very strong sinuous mode of sound waves is radiated when the nozzle-to-plate distance is in the radiation region of the intermittent frequency characteristics. On the contrary, as shown in Fig. 7(b), in the missing parts of the intermittent frequency characteristics, no dominant discrete tones are radiated.

Therefore, it was found from the frequency characteristics of the discrete tone

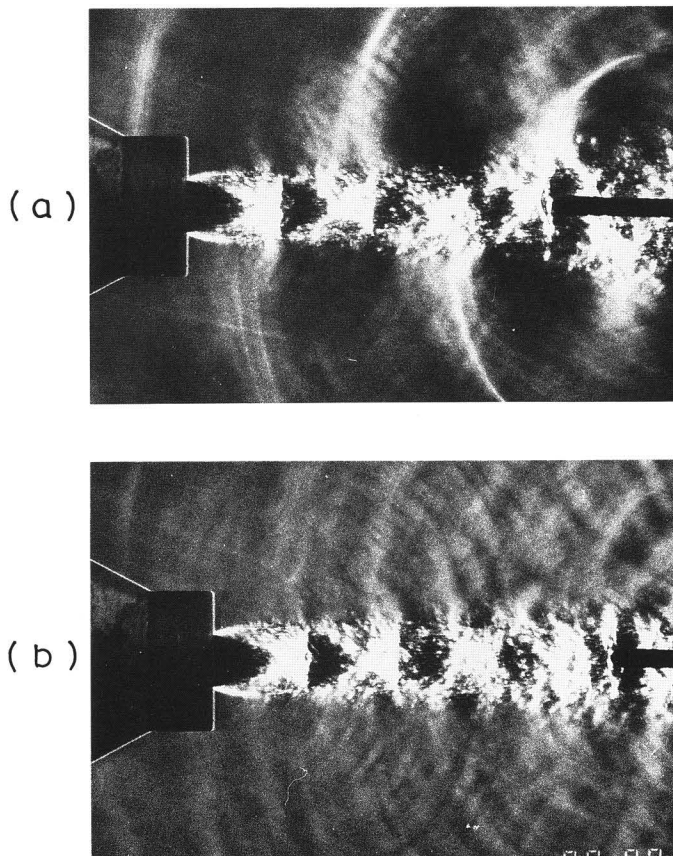


Fig. 7 Schlieren photographs of underexpanded jet for pressure ratio  $R = 4.87$ : (a)  $h/d = 6.8$ , (b)  $h/d = 7.4$ .

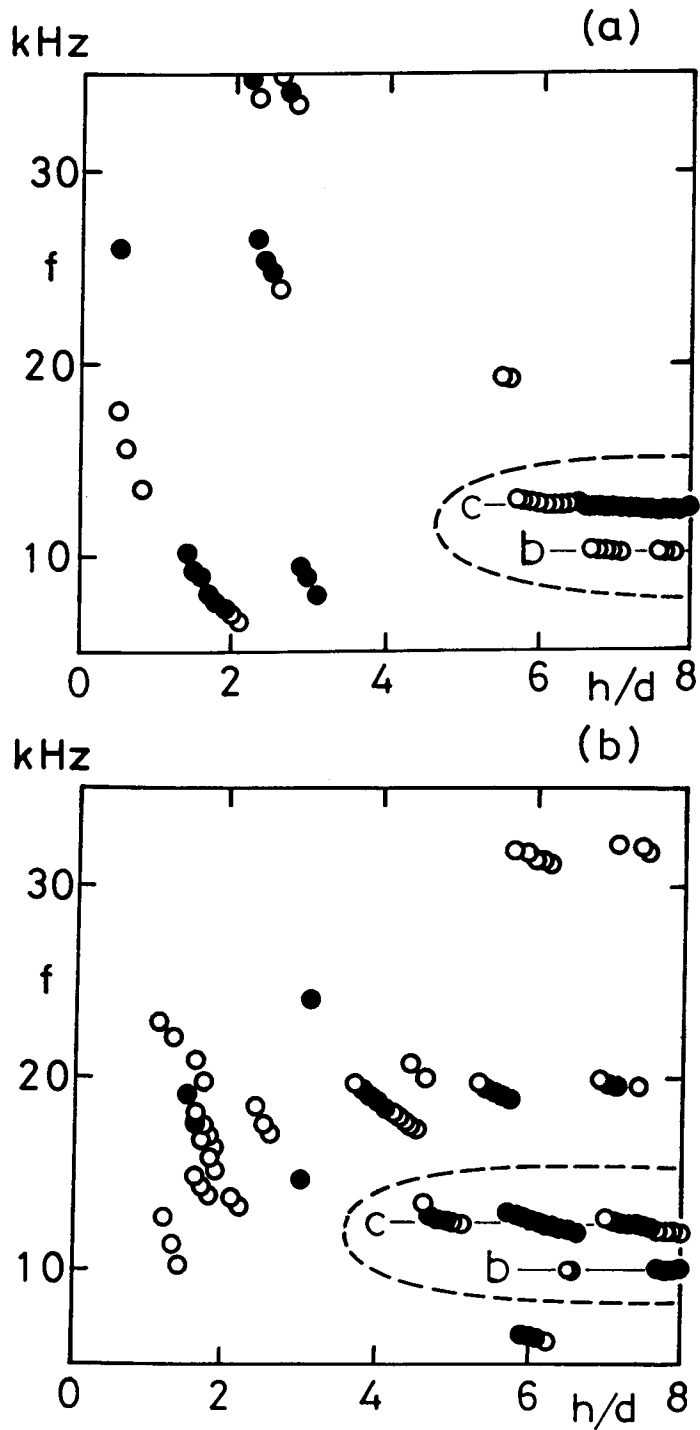


Fig. 8 Frequencies of discrete tone for different sized plates as a function of nozzle-to-plate distance ( $R = 3.90$ ): (a)  $D/d = 1.00$ , (b)  $D/d = 2.00$ .

that the stepwise frequency change occurs in the pressure ratio range  $3.1 < R < 4.5$ , where the dominant helical and secondary sinuous oscillation modes of the free jet were observed. On the contrary, the stepwise frequency change does not occur in the pressure ratio range  $4.6 < R < 5.3$ , where the dominant sinuous and secondary helical oscillation modes of the free jet were observed. This fact shows that the helical oscillation mode of the jet can easily be changed into a sinuous one, but the reverse process can hardly occur.

In order to investigate the size effect of the plate on the frequency characteristics of the discrete tones which belong to the lower frequency group, two other large plates with diameters of  $D/d = 1.0$  and  $2.0$  were used. In Figs. 8(a) and 8(b), the frequencies  $f$  of the discrete tones at the pressure ratio  $R = 3.90$  and the plate diameters  $D/d = 1.0$  and  $2.0$  are plotted against the nozzle-to-plate distance  $h/d$ , respectively. The symbols in these figures are used on the same basis as those in Figs. 3 and 4. At this pressure ratio, it was expected that clear stepwise frequency characteristics would appear, as shown in Fig. 4(f). But, from these figures such a clear stepwise frequency change was not found. The reason why not is considered as follows. When a small plate with a diameter of  $D/d = 0.35$  was placed at about  $h/d = 6$ , the plate exerted only a slight influence on the jet structure. On the other hand, when large plates with diameters of  $D/d = 1.0$  and  $2.0$  were placed at the same distance from the nozzle exit, the plates exerted a more serious influence on the jet structure than the small plate did.

## 5. Conclusions

In the present experiment, when a supersonic circular jet was impinged on a small plate placed concentrically with the nozzle exit, radiation of the screech tone and the impinging tone was observed. Each tone could be discriminated from the frequency characteristics which were obtained when the plate was moved along the jet axis at fixed pressure ratios. It was observed from the experimental results that the frequencies of the screech tone were influenced slightly by the presence of the small plate in the jet. The following interesting phenomena were found in this experiment.

- 1) Three different types of frequency characteristics of screech tone appear depending on the pressure ratio range. They are sawtooth, stepwise and intermittent ones.
- 2) Three types of frequency change of screech tones, by the insertion of a small plate, are repeated periodically with an increasing nozzle-to-plate distance. The travelling length of the plate for one periodic change is almost the same as 1 or

2 times of the first shock cell space of the free jet at the same pressure ratio.

3) The pressure ratio range for the occurrence of the stepwise change of frequency just overlaps that for the helical oscillation mode of the free jet, and that for the radiation of the strong hole tone.

In order to clarify the relationship between the change of frequency characteristics of the screech tone by insertion of the small plate into the jet and the behavior of the underexpanded free jet, further investigation will be needed.

#### Acknowledgements

The first authors (Y.U. and R.I.) received support from the Ministry of Education and Culture of Japan (Grant number c-03805007), the Sound Technology Promotion Foundation and Kyoto University, where the experiments were carried out. The last author (A.P.) received support from the Texas Advanced Research Program (Grant number 003652234-ARP) and from the University of Houston.

#### References

- 1) A. Powell; *The Aeronautical Quarterly*, **4**, 103 (1953).
- 2) A. Powell; *Proc. Phys. Soc. London*, **B**, **66**, 1039 (1953).
- 3) M. G. Davies & D. E. S. Oldfield; *Acustica*, **12**, 267 (1962).
- 4) A. Powell, Y. Umeda and R. Ishii; *AIAA Paper*, 90-3980, (1990).
- 5) A. Powell, Y. Umeda and R. Ishii; Submitted to *J. Acoust. Soc. America*.
- 6) A. Krothapalli; *AIAA J.*, **23**, 1910 (1985).
- 7) A. Powell; *J. Acoust. Soc. America.*, **83**, 515 (1988).
- 8) Y. Umeda, H. Maeda and R. Ishii; *AIAA J.*, **26**, 1036 (1988).
- 9) Y. Umeda, H. Maeda and R. Ishii; *Memoirs of the Faculty of Eng., Kyoto Univ.*, **49**, 174 (1987).
- 10) Y. Umeda, H. Maeda and R. Ishii; *The Physics of Fluids*, **30**, 2380 (1987).