



TITLE:

A New Simple Equation for Obtaining The Strain Distribution of a Granular Bed

AUTHOR(S):

MASUDA, Hiroaki

CITATION:

MASUDA, Hiroaki. A New Simple Equation for Obtaining The Strain Distribution of a Granular Bed. *Memoirs of the Faculty of Engineering, Kyoto University* 1990, 52(1): 1-14

ISSUE DATE:

1990-01-30

URL:

<http://hdl.handle.net/2433/281408>

RIGHT:

A New Simple Equation for Obtaining The Strain Distribution of a Granular Bed

By

Hiroaki MASUDA

(Received August 1, 1989)

Abstract

A new simple equation to estimate the strain distribution of a granular bed is derived based on the mechanics of an elastic body and the hydrodynamics. A new assumption introduced is that stresses caused by strains depend on both the strains and the average stress in the granular bed.

As a simple but typical example to verify the new theory, the strain distribution of a powder bed sandwiched between two parallel plates is discussed. The distribution caused by the slow movement of the upper or lower plate is represented not by a straight line, but a curved line. The simple equation based on the new theory gives a good estimation for the strain distribution.

1. Introduction

The knowledge of strain distributions of granular materials is required in various kinds of particle handling processes in chemical, ceramic, food processing and other related industries. However, it is very difficult to obtain such a knowledge as compared with the case of fluids. If we want to obtain a velocity distribution of a gas or liquid flow, we can utilize the Navier-Stokes equation. We have had, however, no basic equations for the corresponding calculation of granular materials. The aim of this paper is, therefore, to derive a new equation for granular materials like the Navier-Stokes equation for fluids.

I will derive a new simple equation for obtaining the strain-distribution based on the classical hydrodynamics. Then, the equation will be applied to a simple one-dimensional problem, and compared with the experimental results.

2. Strain distributions of granular materials

2.1 Stress-strain relationship for fluids

The relationship between stress and strain for elastic solid bodies is given by Hooke's law, and for fluids it is given by Stokes' law of friction. These two laws are so closely related to each other that in deriving one of them, the other is also obtained at the same time. The only difference between them is that in Hooke's law for elastic bodies, the forces which oppose the deformation of a body are proportional to the magnitude of the strain. Whereas in Stokes' law of friction in fluids, these forces are proportional to the rate-of-strain [1, 2].

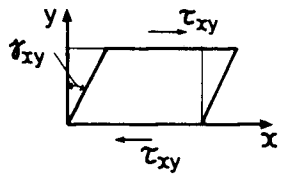
<p style="text-align: center;"><u>Hooke's law</u></p>  <div style="border: 1px solid black; padding: 5px; width: fit-content; margin: 10px auto;"> $\tau_{xy} = G \gamma_{xy}$ $\gamma_{xy} = \frac{\partial \xi}{\partial y} + \frac{\partial \eta}{\partial x}$ </div> <p style="text-align: center;">$E \epsilon_x = \sigma_x - \frac{1}{\nu} (\sigma_x - \sigma_z)$</p>	<p style="text-align: center;"><u>Stokes' law of friction</u></p> $\sigma_x = \bar{\sigma} - \frac{2}{3} \mu \operatorname{div} \mathbf{u} + 2\mu \frac{\partial u}{\partial x}$ <div style="border: 1px solid black; padding: 5px; width: fit-content; margin: 10px auto;"> $\tau_{xy} = \mu \left(\frac{\partial u}{\partial y} + \frac{\partial v}{\partial x} \right)$ </div> <p>u, v : rate of strain ξ, η : magnitude of strain</p>
---	---

Further, we must notice the fact that the relationship between stress and strain can be given only empirically. The basic equations for fluids are represented as follows [1].

$$\left. \begin{aligned} \sigma_x' &= \bar{\sigma} - \frac{2}{3} \mu \left(\frac{\partial u'}{\partial x'} + \frac{\partial v'}{\partial y'} + \frac{\partial w'}{\partial z'} \right) + 2\mu \frac{\partial u'}{\partial x'} \\ \sigma_y' &= \bar{\sigma} - \frac{2}{3} \mu \left(\frac{\partial u'}{\partial x'} + \frac{\partial v'}{\partial y'} + \frac{\partial w'}{\partial z'} \right) + 2\mu \frac{\partial v'}{\partial y'} \\ \sigma_z' &= \bar{\sigma} - \frac{2}{3} \mu \left(\frac{\partial u'}{\partial x'} + \frac{\partial v'}{\partial y'} + \frac{\partial w'}{\partial z'} \right) + 2\mu \frac{\partial w'}{\partial z'} \end{aligned} \right\} \quad (1)$$

Equation (1) shows that: (a) the normal stresses σ_x' , σ_y' , σ_z' are proportional to the quantity $(\partial u'/\partial x' + \partial v'/\partial y' + \partial w'/\partial z')$ which represents the divergence of the time-derivative of the displacement, and (b) the stress σ_x' is proportional to $(\partial u'/\partial x')$ which represents the relative changes in length (elongations) of an elementary volume in the x' direction, and (c) the normal stress σ_x' is given by the summation of the two terms and the average stress $\bar{\sigma}$ (invariant of the stress tensor = $1/3(\sigma_x' + \sigma_y' + \sigma_z')$). In Eq. (1), shear stresses are excluded by an appropriate orthogonal (mathematical) transformation.

The important assumptions made in Eq. (1) are:

- (a) μ is a constant (as far as the temperature and pressure are constant), and
- (b) higher order strains such as $(\partial u' / \partial x')^2$ etc. can be neglected.

The assumption (b) is for linearizing the basic equation. Without the assumption, the equation is very complicated.

The assumption (a) is only empirical, and can be replaced with a new assumption without causing a more complicated mathematical treatment.

2.2 New stress-strain relationship for granular materials

Here, we put a following new assumption ;

$$\mu = \alpha \bar{\sigma} \tag{2}$$

where α is a new constant.

Basic Equations for Fluids

$$\sigma_x = \bar{\sigma} - \frac{2}{3} \mu \operatorname{div} \mathbf{u} + 2\mu \frac{\partial u}{\partial x}$$

$$\mu = \text{const.}$$

Basic Equations for Granular Materials

$$\mu = \alpha \bar{\sigma}$$

$$\alpha = \text{const.}$$

The new assumption means that stresses caused by strains depend both on the strains and the average stress $\bar{\sigma}$. Substituting Eq. (2) into Eq. (1), the following new equations are obtained.

$$\left. \begin{aligned} \sigma_x' &= \bar{\sigma} - \frac{2}{3} \alpha \bar{\sigma} \left(\frac{\partial u'}{\partial x'} + \frac{\partial v'}{\partial y'} + \frac{\partial w'}{\partial z'} \right) + 2\alpha \bar{\sigma} \frac{\partial u'}{\partial x'} \\ \sigma_y' &= \bar{\sigma} - \frac{2}{3} \alpha \bar{\sigma} \left(\frac{\partial u'}{\partial x'} + \frac{\partial v'}{\partial y'} + \frac{\partial w'}{\partial z'} \right) + 2\alpha \bar{\sigma} \frac{\partial v'}{\partial y'} \\ \sigma_z' &= \bar{\sigma} - \frac{2}{3} \alpha \bar{\sigma} \left(\frac{\partial u'}{\partial x'} + \frac{\partial v'}{\partial y'} + \frac{\partial w'}{\partial z'} \right) + 2\alpha \bar{\sigma} \frac{\partial w'}{\partial z'} \end{aligned} \right\} \tag{3 \cdot a}$$

or, in dimensionless form,

$$\left. \begin{aligned} \frac{\sigma'_x}{\bar{\sigma}} &= 1 - \frac{2}{3}\alpha \left(\frac{\partial u'}{\partial x'} + \frac{\partial v'}{\partial y'} + \frac{\partial w'}{\partial z'} \right) + 2\alpha \frac{\partial u'}{\partial x'} \\ \frac{\sigma'_y}{\bar{\sigma}} &= 1 - \frac{2}{3}\alpha \left(\frac{\partial u'}{\partial x'} + \frac{\partial v'}{\partial y'} + \frac{\partial w'}{\partial z'} \right) + 2\alpha \frac{\partial v'}{\partial y'} \\ \frac{\sigma'_z}{\bar{\sigma}} &= 1 - \frac{2}{3}\alpha \left(\frac{\partial u'}{\partial x'} + \frac{\partial v'}{\partial y'} + \frac{\partial w'}{\partial z'} \right) + 2\alpha \frac{\partial w'}{\partial z'} \end{aligned} \right\} \quad (3 \cdot b)$$

Equation (3 · a) can be transformed into an original coordinate system by an orthogonal transformation as follows.

$$\left. \begin{aligned} \sigma_x &= \bar{\sigma} - \frac{2}{3}\alpha\bar{\sigma} \left(\frac{\partial u}{\partial x} + \frac{\partial v}{\partial y} + \frac{\partial w}{\partial z} \right) + 2\alpha\bar{\sigma} \frac{\partial u}{\partial x} \\ \sigma_y &= \bar{\sigma} - \frac{2}{3}\alpha\bar{\sigma} \left(\frac{\partial u}{\partial x} + \frac{\partial v}{\partial y} + \frac{\partial w}{\partial z} \right) + 2\alpha\bar{\sigma} \frac{\partial v}{\partial y} \\ \sigma_z &= \bar{\sigma} - \frac{2}{3}\alpha\bar{\sigma} \left(\frac{\partial u}{\partial x} + \frac{\partial v}{\partial y} + \frac{\partial w}{\partial z} \right) + 2\alpha\bar{\sigma} \frac{\partial w}{\partial z} \\ \tau_{yz} &= \alpha\bar{\sigma} \left(\frac{\partial w}{\partial y} + \frac{\partial v}{\partial z} \right) = \tau_{zy} \\ \tau_{zx} &= \alpha\bar{\sigma} \left(\frac{\partial u}{\partial z} + \frac{\partial w}{\partial x} \right) = \tau_{xz} \\ \tau_{xy} &= \alpha\bar{\sigma} \left(\frac{\partial v}{\partial x} + \frac{\partial u}{\partial y} \right) = \tau_{yx} \end{aligned} \right\} \quad (3 \cdot c)$$

2.3 Energy dissipation caused by powder movement

Based on Eq. (3), the rate at which work is being done in changing the volume and shape of a rectangular element ($dx dy dz$) is given by

$$\begin{aligned} \Phi dx dy dz &= \bar{\sigma} \left(\frac{\partial u}{\partial x} + \frac{\partial v}{\partial y} + \frac{\partial w}{\partial z} \right) dx dy dz + \\ &\quad \left[-\frac{2}{3}\alpha\bar{\sigma} \left(\frac{\partial u}{\partial x} + \frac{\partial v}{\partial y} + \frac{\partial w}{\partial z} \right)^2 + \alpha\bar{\sigma} \left\{ 2 \left(\frac{\partial u}{\partial x} \right)^2 + 2 \left(\frac{\partial v}{\partial y} \right)^2 + \right. \right. \\ &\quad \left. \left. 2 \left(\frac{\partial w}{\partial z} \right)^2 + \left(\frac{\partial w}{\partial y} + \frac{\partial v}{\partial z} \right)^2 + \left(\frac{\partial u}{\partial z} + \frac{\partial w}{\partial x} \right)^2 + \right. \right. \\ &\quad \left. \left. \left(\frac{\partial v}{\partial x} + \frac{\partial u}{\partial y} \right)^2 \right\} \right] dx dy dz \end{aligned} \quad (4)$$

If we integrate Eq. (4) over the whole volume of the powder bed, we get a total dissipation.

In a case where the variation of density can be neglected, we have the following equation.

$$\text{div. } \underline{u} = \frac{\partial u}{\partial x} + \frac{\partial v}{\partial y} + \frac{\partial w}{\partial z} = 0 \quad (5)$$

Substituting Eq. (5) into Eq. (4), the following equation is obtained.

$$\Phi dx dy dz = \alpha \bar{\sigma} \left\{ 2 \left(\frac{\partial u}{\partial x} \right)^2 + 2 \left(\frac{\partial v}{\partial y} \right)^2 + 2 \left(\frac{\partial w}{\partial z} \right)^2 + \left(\frac{\partial w}{\partial y} + \frac{\partial v}{\partial z} \right)^2 + \left(\frac{\partial u}{\partial z} + \frac{\partial w}{\partial x} \right)^2 + \left(\frac{\partial v}{\partial x} + \frac{\partial u}{\partial y} \right)^2 \right\} dx dy dz \quad (6)$$

2.4 Euler's equation

In order to obtain the strain distribution, we can adopt the variation-principle.

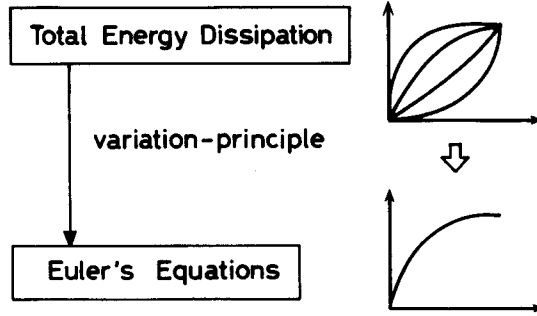

The functional for the problem is given by the total energy dissipation:

$$I = \iiint \Phi \left(\frac{\partial u}{\partial x}, \frac{\partial u}{\partial y}, \frac{\partial u}{\partial z}, \frac{\partial v}{\partial x}, \frac{\partial v}{\partial y}, \frac{\partial v}{\partial z}, \frac{\partial w}{\partial x}, \frac{\partial w}{\partial y}, \frac{\partial w}{\partial z} \right) dx dy dz \quad (7)$$

Euler's equations of the functional (7) are given by the following set of equations.

$$\left. \begin{aligned} \frac{\partial}{\partial x} \Phi_{p_1} + \frac{\partial}{\partial y} \Phi_{q_1} + \frac{\partial}{\partial z} \Phi_{r_1} &= 0 \\ \frac{\partial}{\partial x} \Phi_{p_2} + \frac{\partial}{\partial y} \Phi_{q_2} + \frac{\partial}{\partial z} \Phi_{r_2} &= 0 \\ \frac{\partial}{\partial x} \Phi_{p_3} + \frac{\partial}{\partial y} \Phi_{q_3} + \frac{\partial}{\partial z} \Phi_{r_3} &= 0 \end{aligned} \right\} \quad (8)$$

where,

$$\left. \begin{aligned} p_1 &= \frac{\partial u}{\partial x}, p_2 = \frac{\partial v}{\partial x}, p_3 = \frac{\partial w}{\partial x} \\ q_1 &= \frac{\partial u}{\partial y}, q_2 = \frac{\partial v}{\partial y}, q_3 = \frac{\partial w}{\partial y} \\ r_1 &= \frac{\partial u}{\partial z}, r_2 = \frac{\partial v}{\partial z}, r_3 = \frac{\partial w}{\partial z} \end{aligned} \right\} \quad (9)$$

and

$$\Phi_{p_1} = \frac{\partial \Phi}{\partial p_1}, \quad \dots \quad (9 \cdot a)$$

From Eq. (8) and Eq. (4), we get the following set of equations.

$$\left. \begin{aligned} & \frac{\partial}{\partial x} \left\{ \bar{\sigma} - \frac{4}{3} a \bar{\sigma} (p_1 + q_2 + r_3) + 4a \bar{\sigma} p_1 \right\} + \\ & \quad \frac{\partial}{\partial y} \{ 2a \bar{\sigma} (p_2 + q_1) \} + \frac{\partial}{\partial z} \{ 2a \bar{\sigma} (r_1 + p_3) \} = 0 \\ & \frac{\partial}{\partial x} \{ 2a \bar{\sigma} (p_2 + q_1) \} + \\ & \quad \frac{\partial}{\partial y} \left\{ \bar{\sigma} - \frac{4}{3} a \bar{\sigma} (p_1 + q_2 + r_3) + 4a \bar{\sigma} q_2 \right\} + \\ & \quad \frac{\partial}{\partial z} \{ 2a \bar{\sigma} (q_3 + r_2) \} = 0 \\ & \frac{\partial}{\partial x} \{ 2a \bar{\sigma} (r_1 + p_3) \} + \frac{\partial}{\partial y} \{ 2a \bar{\sigma} (q_3 + r_2) \} + \\ & \quad \frac{\partial}{\partial z} \left\{ \bar{\sigma} - \frac{4}{3} a \bar{\sigma} (p_1 + q_2 + r_3) + 4a \bar{\sigma} r_3 \right\} = 0 \end{aligned} \right\} \quad (10 \cdot a)$$

$$\text{where, } p_1 + q_2 + r_3 = \frac{\partial u}{\partial x} + \frac{\partial v}{\partial y} + \frac{\partial w}{\partial z} = \text{div. } \underline{u}$$

In a case where the variation of density can be neglected, we get the following set of equations from Eqs. (6) and (8).

$$\left. \begin{aligned} & \frac{\partial}{\partial x} \left\{ 4a \bar{\sigma} \frac{\partial u}{\partial x} \right\} + \frac{\partial}{\partial y} \left\{ 2a \bar{\sigma} \left(\frac{\partial v}{\partial x} + \frac{\partial u}{\partial y} \right) \right\} + \frac{\partial}{\partial z} \left\{ 2a \bar{\sigma} \left(\frac{\partial u}{\partial z} + \frac{\partial w}{\partial x} \right) \right\} = 0 \\ & \frac{\partial}{\partial x} \left\{ 2a \bar{\sigma} \left(\frac{\partial v}{\partial x} + \frac{\partial u}{\partial y} \right) \right\} + \frac{\partial}{\partial y} \left\{ 4a \bar{\sigma} \frac{\partial v}{\partial y} \right\} + \frac{\partial}{\partial z} \left\{ 2a \bar{\sigma} \left(\frac{\partial w}{\partial y} + \frac{\partial v}{\partial z} \right) \right\} = 0 \\ & \frac{\partial}{\partial x} \left\{ 2a \bar{\sigma} \left(\frac{\partial u}{\partial z} + \frac{\partial w}{\partial x} \right) \right\} + \frac{\partial}{\partial y} \left\{ 2a \bar{\sigma} \left(\frac{\partial w}{\partial y} + \frac{\partial v}{\partial z} \right) \right\} + \frac{\partial}{\partial z} \left\{ 4a \bar{\sigma} \frac{\partial w}{\partial z} \right\} = 0 \end{aligned} \right\} \quad (10 \cdot b)$$

Since the parameter a is constant, Eq. (10 · b) is further simplified as follows:

$$\left. \begin{aligned} & 2 \frac{\partial}{\partial x} \left(\bar{\sigma} \frac{\partial u}{\partial x} \right) + \frac{\partial}{\partial y} \left\{ \bar{\sigma} \left(\frac{\partial v}{\partial x} + \frac{\partial u}{\partial y} \right) \right\} + \frac{\partial}{\partial z} \left\{ \bar{\sigma} \left(\frac{\partial u}{\partial z} + \frac{\partial w}{\partial x} \right) \right\} = 0 \\ & \frac{\partial}{\partial x} \left\{ \bar{\sigma} \left(\frac{\partial v}{\partial x} + \frac{\partial u}{\partial y} \right) \right\} + 2 \frac{\partial}{\partial y} \left(\bar{\sigma} \frac{\partial v}{\partial y} \right) + \frac{\partial}{\partial z} \left\{ \bar{\sigma} \left(\frac{\partial w}{\partial y} + \frac{\partial v}{\partial z} \right) \right\} = 0 \\ & \frac{\partial}{\partial x} \left\{ \bar{\sigma} \left(\frac{\partial u}{\partial z} + \frac{\partial w}{\partial x} \right) \right\} + \frac{\partial}{\partial y} \left\{ \bar{\sigma} \left(\frac{\partial w}{\partial y} + \frac{\partial v}{\partial z} \right) \right\} + 2 \frac{\partial}{\partial z} \left(\bar{\sigma} \frac{\partial w}{\partial z} \right) = 0 \end{aligned} \right\} \quad (10 \cdot c)$$

Equation 10 (a, b, c) is the basic equation for representing the strain-distributions of granular materials. Application of the equation will be shown in the next section.

3. Strain-distributions of a powder bed sandwiched between two parallel plates

We will discuss a simple one-dimensional problem. The problem is shown in Fig. 1.

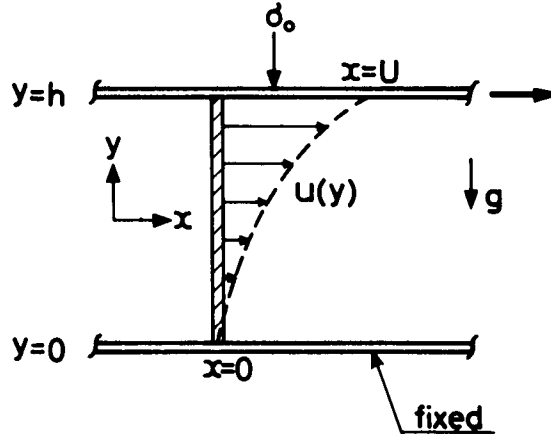

Fig. 1 Strain-distribution of a powder bed sandwiched between two parallel plates, case (a) upper plate was moved

The depth of the powder bed is represented by h , and the powder bed is compressed by normal stress σ_0 . Now, the upper plate is moved to the right. What is the strain-distribution of the powder bed?

The strain-distribution is a function of y , and it does not depend on x and z . Therefore,

$$u = u(y), \quad v = w = 0 \tag{11}$$

Then, Euler's equation (10 • c) gives

$$\frac{d}{dy} \left(\bar{\sigma} \frac{du}{dy} \right) = 0 \tag{12}$$

or,

$$\bar{\sigma} \frac{d^2u}{dy^2} + \frac{d\bar{\sigma}}{dy} \cdot \frac{du}{dy} = 0 \tag{12 \cdot a}$$

The average stress $\bar{\sigma}$ at height y is given by the summation of the normal stress σ_0 and the weight of the powder bed, with thickness $(h-y)$.

$$\bar{\sigma} = \sigma_0 + \rho_B g(h-y), \quad \sigma_0 \neq 0 \quad (13)$$

where ρ_B is the bulk density of the powder bed. Substituting Eq. (13) into Eq. (12 • a), the following equation is obtained.

$$(\sigma_0 + \rho_B g h - \rho_B g y) \frac{d^2 u}{dy^2} - \rho_B g \frac{du}{dy} = 0 \quad (14)$$

The solution of Eq. (14) is given by

$$u(y) = -C_1 \ln(\sigma_0 + \rho_B g h - \rho_B g y) + C_2 \quad (15)$$

where, C_1 and C_2 are the integral constants. Now the boundary conditions are

$$\begin{aligned} u &= 0 \text{ at } y=0, \text{ and} \\ u &= U \text{ at } y=h \end{aligned} \quad (16)$$

Then the strain-distribution $u(y)/U$ is determined as follows:

$$\frac{u(y)}{U} = \frac{\ln\left(1 - \frac{\rho_B g h}{\sigma_0 + \rho_B g h} \cdot \frac{y}{h}\right)}{\ln\left(1 - \frac{\rho_B g h}{\sigma_0 + \rho_B g h}\right)} \quad (17)$$

Figure 2 shows the calculated strain distributions.

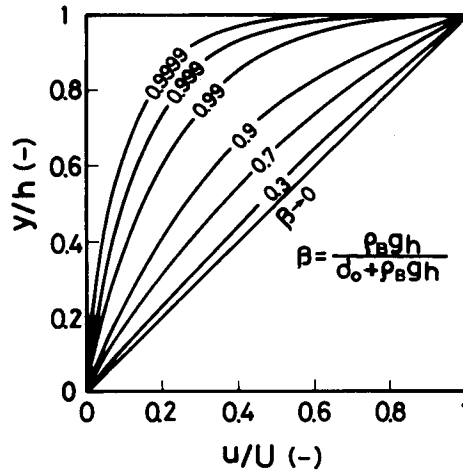

Fig. 2 Strain distributions calculated by Eq.(17)

At the limit of $\rho_B gh / (\sigma_0 + \rho_B gh) \rightarrow 0$, we have the following relation.

$$\lim_{\beta \rightarrow 0} \frac{u(y)}{U} = \lim_{\beta \rightarrow 0} \frac{1 - \beta}{1 - \beta \frac{y}{h}} \cdot \frac{y}{h} = \frac{y}{h} \quad (18)$$

where,

$$\beta = \frac{\rho_B gh}{\sigma_0 + \rho_B gh} \quad (19)$$

Namely, the limiting strain distribution is given by

$$\frac{u(y)}{U} = \frac{y}{h} \quad (\beta \rightarrow 0 \text{ or } \sigma_0 \rightarrow \infty) \quad (20)$$

which is similar to the velocity distribution of the Newtonian fluids. The condition $\beta = 0$ implies that the gravity effect can be neglected as compared with the normal stress σ_0 . (As for the fluid, there is no void in it, and σ_0 is equal to the atmospheric pressure.) If we consider the velocity distribution in the very deep sea, the gravity effect could not be neglected. Also, the velocity distribution (or strain distribution, see also § 2. 1) might be distorted, as shown in Fig. 2.

For the other limit of $\sigma_B gh / (\sigma_0 + \rho_B gh) \rightarrow 1$, or $\sigma_0 \rightarrow 0$, we have the following relation.

$$\lim_{\beta \rightarrow 1} \frac{u(y)}{U} = 0 \quad (21)$$

Equation (21) implies that only the upper surface of the powder bed can move along with the upper plate.

Now, we will discuss the next problem shown in Fig. 3.

In this case, the lower plate moves to the right. What is the strain-distribution of the powder bed? We know that the velocity-distribution of the Newtonian fluid is represented by a straight line.

Euler's equation is given by Eq. (12), and the average stress $\bar{\sigma}$ is given by Eq. (13). The only differences between the two problems (a) and (b) are the boundary conditions. That is,

$$\begin{aligned} u &= 0 \text{ at } y = h, \text{ and} \\ u &= U \text{ at } y = 0 \end{aligned} \quad (22)$$

Then the strain-distribution $u(y)/U$ is obtained as follows:

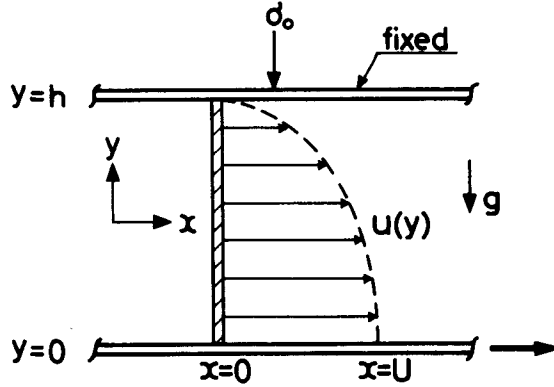

Fig. 3 Strain-distribution of a power bed sandwiche between two parallel plates, case (b) lower plate was moved

$$\frac{u(y)}{U} = \frac{\ln\left\{1 + \frac{\rho_B g h}{\sigma_0} \left(1 - \frac{y}{h}\right)\right\}}{\ln\left(1 + \frac{\rho_B g h}{\sigma_0}\right)} \quad (23)$$

From Eq. (19), we have the following equation.

$$\frac{\rho_B g h}{\sigma_0} = \frac{\beta}{1-\beta} \quad (24)$$

Substituting Eq. (24) into Eq. (23), we get

$$\frac{u(y)}{U} = \frac{\ln\left(\frac{1-\beta\frac{y}{h}}{1-\beta}\right)}{\ln\left(\frac{1}{1-\beta}\right)} \quad (25 \cdot a)$$

Therefore,

$$\frac{u(y)}{U} = 1 - \frac{\ln\left(1-\beta\frac{y}{h}\right)}{\ln(1-\beta)} \quad (25 \cdot b)$$

If we denote the strain-distribution for the second problem as $(u/U)_{II}$, and for the first $(u/U)_I$, the following relationship can be obtained.

$$\left(\frac{u}{U}\right)_I + \left(\frac{u}{U}\right)_{II} = 1 \tag{26}$$

Equation (26) implies that the two distributions are virtually the same, and both of them are represented by Fig 2. The only difference is that the lower plate moves to the left and the upper plate is fixed, for the second problem.

The readers may remember an unsteady laminar flow near a wall. The velocity distribution is given by the following equation [3] :

$$\frac{\dot{u}}{V} = 1 - \operatorname{erf}\left(\frac{y}{\sqrt{4\nu t}}\right) \tag{27}$$

where V is the velocity of the wall, ν is the kinematic viscosity, and t is the time elapsed (see Fig. 4).

The distribution (a) in Fig. 4 is very similar to Fig. 1, but (b) is completely different from Fig. 3. Equation (10 a, b, c) can represent the completely different

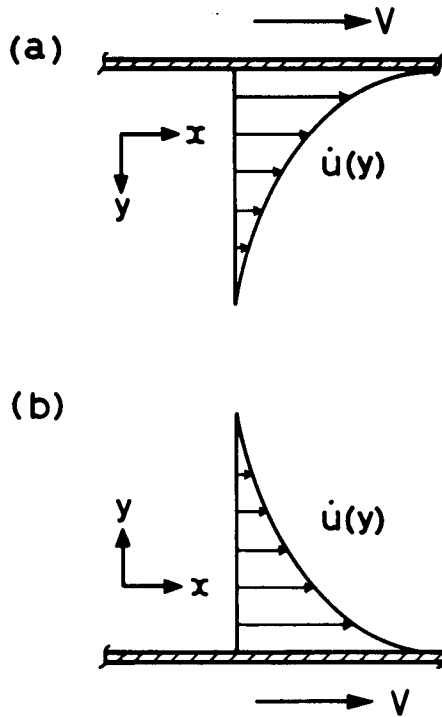

Fig. 4 Viscous flow of a fluid near a wall suddenly set in motion

strain distributions from these of the Newtonian fluid.

4. Experiments

— Experimental verification of the strain-distributions
of a powder bed sandwiched between two parallel plates —

In the preceding section, we studied the ideal case of a powder bed sandwiched between infinitely wide parallel plates. Of course, infinitely wide plates can never exist, and the following experiment was carried out in order to verify the theoretical results.

Experiment: Powder (quartz sand No. 5, bulk density $\rho_B = 1.36 \text{ g/cm}^3$, angle of repose $\phi_r = 35.5^\circ$, mass median diameter $D_{p50} = 440 \mu\text{m}$) was sandwiched between two parallel plates as shown in Fig. 5.

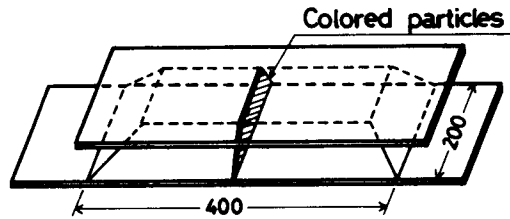

Fig. 5 Powder bed sandwiched by two parallel plates

The surfaces of the two plates were covered by emery papers so that particles did not slip at the plate surfaces. Colored particles were used to show the center line of the powder bed. A load of approximately 1 gf/cm^2 ($= 980 \text{ dyne/cm}^2$) was applied on the upper plate by use of a suitable weight. Then we pulled the upper plate (or lower plate) to the right very slowly. Then, a thin solution of Japanese isinglass was percolated into the powder bed in order to solidify it. The powder bed, after a few hours elapsed, was cut along the center line of a longitudinal direction.

some comments on the experiment

- (a) If we packed the powder in a box instead of the heap of the powder, side walls might affect the strain distributions.
- (b) It was unavoidable that the height of the powder bed became lower during the experiment, because the side parts of the powder bed crumbled down.
- (c) The given strain U was not large enough because of the crumbling. The experimental value of U was about 2 cm.
- (d) The load applied on the powder bed was obtained rather approximately

because the area of the upper surface of the powder bed decreased during the experiment.

(e) The parameter β for the experiment was calculated by Eq. (19) as follows :

$$\beta = \frac{1.36 \times 980 \times 5}{980 + 1.36 \times 980 \times 5} = 0.872 \quad [-]$$

experimental results

The experimental results are shown in Fig. 6. Figure 6 (a) shows the strain -distribution resulting from the upper plate movement. The broken line shows the calculated results based on Eq. (17).

There are some differences between the experimental and the theoretical results. However, the tendency that the strain near the upper plate is larger than in lower part is represented well by the new theory.

Figure 6 (b) shows the strain-distribution resulting from the lower plate movement. In this case, the strain near the lower plate is larger than in the upper part. The broken line shows the calculated results based on Eq. (25 • b). The following relation holds exactly.

$$\left(\frac{u}{U}\right)_{I, \text{exp}} + \left(\frac{u}{U}\right)_{II, \text{exp}} = 1 \tag{28}$$

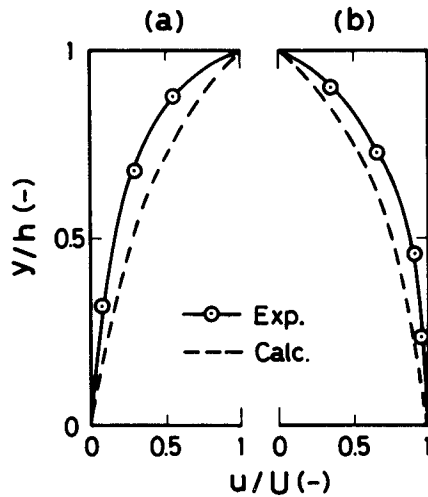

Fig. 6 Experimental results
 (a) upper plate was moved to the right
 (b) lower plate was moved to the right

5. Conclusion

A new simple equation to estimate the strain distributions of a granular bed was obtained based on the mechanics of an elastic body or the hydrodynamics. The new assumption introduced is that stresses caused by strains depend on both the strains and the average stress in the granular bed.

As a simple but typical example to verify the new theory, the strain distributions of a powder bed sandwiched between two parallel plates were discussed. The distribution caused by the slow movement of the upper or lower plate was represented not by a straight line, but a curved line. The fact shows one of the typical features of the strain-distribution of a granular bed as compared with that of a Newtonian fluid. The simple equation based on the new theory gave a new possible method for estimating the strain distribution of a granular bed.

The theory can also be applied to a three dimensional problem. It is also possible to derive a new equation of motion for granular materials which corresponds to the Navier-Stokes equation for the Newtonian fluid.

References

- 1) H. Lamb; "Hydrodynamics", Cambridge Univ. Press, p. 572 (1932)
- 2) H. Schlichting; "Boundary Layer Theory", translated by J. Kestin, McGraw-Hill, Chap. 3 (1955)
- 3) R. B. Bird, W. E. Stewart and E. N. Lightfoot; "Transport Phenomena", John Wiley & Sons, Inc., p. 124 (1960)