



TITLE:

# Reduced-order Models of Power Systems based on Controllability and Observability

AUTHOR(S):

MATSUKI, Junya; M. S. A. A. HAMMAM

---

CITATION:

MATSUKI, Junya ...[et al]. Reduced-order Models of Power Systems based on Controllability and Observability. *Memoirs of the Faculty of Engineering, Kyoto University* 1989, 51(3): 153-168

ISSUE DATE:

1989-07-30

URL:

<http://hdl.handle.net/2433/281397>

RIGHT:

# Reduced-order Models of Power Systems based on Controllability and Observability

By

Junya MATSUKI\* and M. S. A. A. HAMMAM\*\*

(Received March 26, 1989)

## Abstract

Reduced-order models for dynamic control of power systems are formulated using a modal analysis technique, based on the notion of controllability and observability. In this technique, an input/output index is used to identify and rank the strongly controllable and observable modes of the system given a particular input/output pair. The system state variables that are strongly related to the retained modes are then determined by analysis of a participation factor matrix. Davison's method of reducing linear systems is then applied to formulate the desired reduced order dynamic equivalent. This technique of forming dynamic equivalents is investigated on a single machine infinite bus system. Several reduced order model equivalents are formed and evaluated on their performance and accuracy.

## 1. INTRODUCTION

In the mid 1960's, interest began to rise in the area of dynamic equivalents as simulations of increasingly larger interconnected power systems were required. By the late 1960's, the academic community had proposed various techniques for determining dynamic equivalents. From these techniques two successful methods emerged ; modal analysis and coherency analysis. Coherency analysis involves the identification of machines that swing together and the formation of a composite model of these machines. Coherency analysis was mentioned here only for completeness. The rest of this discussion will be concerned with modal analysis.

Modal analysis involves the identification of decoupled modes within the system which are present in the states and the outputs of the system. The modes (eigenvalues) of the system that have little affect on the states and outputs of interest can be neglected yielding reduced order models. As the number of neglected modes increase, the reduced order model becomes increasingly stiff and less accurate. Various modal analysis techni-

---

\* Department of Electrical Engineering.

\*\* Clarkson University, USA.

ques were proposed by Davison<sup>1)</sup>, Undrill<sup>2,3)</sup>, Altalib and Krause<sup>4)</sup>, Kuppurajula and Elangovan<sup>5)</sup>, and Perez-Arriaga et. al.<sup>6,7)</sup>.

In Davison's proposed method, the eigenvalues of the original system which are farthest from the origin are neglected since they have little affect on the dynamic behavior of the system. The method is unique in that it provides a means of retaining the dominant eigenvalues of the system identically. Although Davison's method for selecting the dominant modes of the system is somewhat crude, the reduction technique itself is the basis for almost all modal analysis techniques.

Undrill, Kuppaurajula and Elangovan applied Davison's method to multimachine systems with somewhat successful results. Undrill proposed a criterion for selecting the dominant modes of the system based on the right and left eigenvectors of the system, while Kuppurajula and Elangovan directly applied Davison's method to the power system.

Kuppurajula and Elangovan also proposed a method of forming dynamic equivalents based on a state variable grouping technique. This technique is based on dividing the system variables into groups according to their speeds of response. This method requires a previous knowledge of the approximate time response of the state variables and, for this reason, often produced inaccurate reduced order models.

Perez-Arriaga, Verghese and Schweppe proposed a technique for forming reduced order models based on the participation matrix. The technique is very similar to Davison's method, except that the retained modes and state variables are selected by analysis of a participation factor matrix. The participation factor matrix measures the relative participan of modes in certain state variables and vice versa. They also proposed an iterative algorithm for calculating the dominant eigenvalues and the eigenvectors of the system with respect to the outputs of interest without performing an eigenvalue analysis of the complete system. Although this technique provides a most efficient means of formulating dynamic equivalents, it currently is applicable only to systems whose dynamic performance is well understood. Further research is needed to investigate the potential of this reduction technique.

Altalib and Krause investigated the possibility of combining reduced order models formulated by Davison's method in a two machine infinite bus system. They were able to combine the reduced order models of the single machines and retain the dominant eigenvalues of the rotor oscillations accurately. If this technique could be applied to systems with a larger number of input/output constraints, it would significantly improve the efficiency of Davison's method in formulating dynamic equivalents of larger power systems.

In 1980, Castro-Leon<sup>8)</sup> proposed a new modal analysis technique for determining dynamic equivalents. He proposed an input/output index to identify and rank the

strongly controllable and observable modes of the power system given a particular input/output pair. He combined the input/output index with Davison's method of simplifying linear systems to formulate the desired reduced order models. From the input/output index it is possible to determine the maximum error of the reduced order models without performing time consuming simulations. This provides a means of analyzing the efficiency versus accuracy of various reduced order models which is a great improvement over all other reduction techniques previously discussed.

## 2. Dynamic equivalents based on controllability and observability

In this section modal analysis is used to determine dynamic equivalents of the power system. The power system is linearized about its operating point, and modern control theory techniques are applied to formulate an input/output index based on controllability and observability. The input/output index identifies the strongly controllable and observable modes of the system and allows them to be ranked accordingly. This provides a means of selecting the dominant modes of the system for system reduction. A participation factor matrix is then used to select the state variables that are strongly related to the retained modes. These two techniques, combined with Davison's method of simplifying linear systems, provide a means of determining reduced order models.

### 2. 1 Input/output index

Assuming the original linearized state space model of the power system is given by

$$\dot{X} = AX + BU \quad (2.1)$$

and the output equation is expressed as

$$Y = CX \quad (2.2)$$

where :

- X = state vector (order n)
- A = plant matrix (n × n)
- B = input matrix (n × k)
- U = input vector (order k)
- Y = output vector (order m)
- C = output matrix (m × n)

Assuming the initial state vector is zero and the input to the system is a step function, then the time solution of Equation (2.1) is

$$X(t) = \int_0^t e^{A(t-\tau)} d\tau BU \quad (2.3)$$

Integrating Equation (2.3) yields

$$X(t) = -MA^{-1}(I - e^{At})M^{-1}BU \quad (2.4)$$

where :

$M$  = right eigenvector matrix

$\Lambda$  = diagonal eigenvalue matrix

The output vector  $Y$  can then be expressed as

$$Y(t) = -CMA^{-1}(I - e^{At})M^{-1}BU \quad (2.5)$$

expanding Equation (2.5)

$$Y_i(t) = - \sum_{l=1}^k \left[ \sum_{j=1}^n \sum_{k=1}^n C_{ik} M_{kj} \sum_{L=1}^n N_{jL} B_{Ll} \frac{1 - e^{\lambda_j t}}{\lambda_j} \right] U_l \quad i=1, m \quad (2.6)$$

From an inspection of Equation (2.6), it is evident that the first summation involves the vector products of the output matrix  $C$  and the right eigenvector matrix  $M$ . It is a measure of how observable mode  $j$  is in output  $i$ . The second summation involves the vector products of the input matrix  $B$  and the inverse of the eigenvector matrix  $N$ . It is a measure of how controllable mode  $j$  is through input  $U_l$ . These two concepts are combined to formulate the following input/output index based on controllability and observability.

$$T_{ijl} = - \left[ \sum_{k=1}^n C_{ik} M_{kj} \sum_{L=1}^n N_{jL} B_{Ll} \right] / \lambda_j \quad (2.7)$$

$T_{ijl}$  is the input/output index and represents the contribution of mode  $j$  to output  $i$  from input  $l$ . The output equation can now be expressed as

$$Y_i(t) = \sum_{l=1}^k \sum_{j=1}^n T_{ijl} (1 - e^{\lambda_j t}) U_l \quad i=1, m \quad (2.8)$$

Equation (2.8) illustrates that the input/output index is a matrix of the output coefficients. The magnitude of the input/output index can be calculated as

$$|T_{ijl}| = [Re(T_{ijl})^2 + Im(T_{ijl})^2]^{1/2} \quad (2.9)$$

The modes of the system can now be ranked according to the magnitude of their input/output index.

## 2. 2 Participation factor matrix

In order to utilize Davison's method of simplifying linear systems it is first necessary to select the state variables of the system which are strongly related to the retained modes. If these state variables are not chosen adequately, Davison's method will yield inaccurate results.

In 1982, Perez-Arriaga, Verghese and Schweppe<sup>7)</sup> proposed and illustrated that there exist associations between groups of state variables and groups of natural modes of the system, and that these associations could be defined by means of a participation factor matrix. The participation factor matrix was shown to yield more precise information regarding state variable-mode relationships than did the traditional right eigenvector analysis. The participation matrix  $P$  is defined in the following way

$$P = [P_{ki}] = |M_{ki} N_{ki}| \quad (2.10)$$

where :

$M_{ki}$  =  $k$ th entry of the  $i$ th right eigenvector

$N_{ki}$  =  $k$ th entry of the  $i$ th left eigenvector

The eigenvectors are normalized such that

$N_i^T M_j = 1$  if  $i=j$ ; 0 otherwise

The elements of P are the magnitudes of the products  $M_{ki}$  and  $N_{ki}$ , and are termed participation factors of the system.  $M_{ki}$  measures the activity of  $X_k$  in the  $i$ th mode, and  $N_{ki}$  weighs the contribution of the activity. Therefore,  $P_{ki}$  measures the relative participation of the  $k$ th state variable to the  $i$ th mode, and vice versa.

### 2. 3 Error analysis

One of the major advantages of using the input/output index is the ability to determine the maximum errors of the reduced order models without actually simulating them. The system output equation can be expressed as illustrated in Equation (2.8).

$$Y_i(t) = \sum_{l=1}^k \sum_{j=1}^n T_{ijl} (1 - e^{\lambda_l t}) U_l$$

An approximate response by including modes in set 1 is

$$\widehat{Y}(t) = \sum_{l=1}^k \sum_{j \in 1} T_{ijl} (1 - e^{\lambda_l t}) U_l \tag{2.11}$$

The error between the actual response and the approximate response can then be expressed as

$$\Delta Y_i = |Y - \widehat{Y}| = \left| \sum_{l=1}^k \sum_{j \notin 1} T_{ijl} (1 - e^{\lambda_l t}) U_l \right| \tag{2.12}$$

$$\Delta Y_i \leq \sum_{l=1}^k \sum_{j \notin 1} |T_{ijl}| |1 - e^{\lambda_l t}| U_l \tag{2.13}$$

Thus, the maximum error can be expressed as

$$\Delta Y_i \leq 2 \sum_{l=1}^k \sum_{j \notin 1} |T_{ijl}| U_l \tag{2.14}$$

### 2. 4 Davison's method

Davison's method will formulate the following reduced order model

$$\dot{X}^* = A^* X^* = B^* U(t) \tag{2.15}$$

$$Y = C^* X^* \tag{2.16}$$

where the reduced order  $A^*$  matrix has the same  $l$  eigenvalues retained from the from the original system and the correct eigenvectors with respect to these  $l$  eigenvalues. The new dimensions of matrices  $A^*$ ,  $B^*$  and  $C^*$  are  $(l^*1)$ ,  $(l^*k)$  and  $(m^*1)$  respectively.

### 3. Computational results

#### 3.1 System description

The study system is a single machine connected to an infinite bus. It serves as a simple example and provides insight into further possible applications of the reduction technique.

The system's main components consist of a 5th order winding representation of a synchronous machine based on Park's equations, a 4th order automatic voltage regulator (AVR) and exciter, a 2nd order shaft and a 2nd order turbine governor system, yielding a total 13th order model.

Table 3.1 Single machine data

Symbol	Description	Value (p. u.)
$R_a$	Stator resistance	0.0032
$R_q$	q-damper winding resistance	0.014
$R_D$	d-damper winding resistance	0.011
$R_F$	Field winding resistance	0.001
$R_L$	Transmission line resistance	0.02
$X_L$	Transmission line reactance	0.2
$X_{md}$	d-axis magnetizing reactance	1.56
$X_{mq}$	q-axis magnetizing reactance	1.47
$X_{la}$	Stator leakage reactance	0.093
$X_{lq}$	q-damper leakage reactance	0.032
$X_{lD}$	d-damper leakage reactance	0.048
$X_{lfd}$	Field winding leakage reactance	0.086

Table 3.2 AVR and exciter data

Symbol	Description	Value (p. u.)
$K_a$	Amplifier gain	50.0
$K_e$	Exciter gain	13.89
$K_r$	AVR gain	1.0
$K_s$	Stabilizer gain	0.057
$T_a$	Amplifier time constant	0.02s
$T_e$	Exciter time constant	2.028s
$T_r$	AVR time constant	0.001s
$T_s$	Stabilizer time constant	0.45s

Table 3.3 Mechanical machine data

Symbol	Description	Value (p. u.)
$M$	Inertia constant	0.014s <sup>2</sup>
$D$	Damping coefficient	0.0
$T_g$	Governor time constant	0.25s
$T_t$	Steam-turbine time constant	1.0s
$R$	Steady-state speed regulation	0.5 × 120π

Table 3.4 Operating point data

Symbol	Description	Value (p. u.)
$V_T$	Terminal voltage	1.14
$P$	Real power	0.8
$Q$	Reactive power	0.6
$V_d$	d-axis voltage	-0.9611
$V_q$	q-axis voltage	1.7248
$I_d$	d-axis current	-1.3880
$I_q$	q-axis current	0.6180
$I_F$	Field current	2.5776
$\delta$	Power angle	36.38°



Figures 3.1 Single machine infinite bus system.

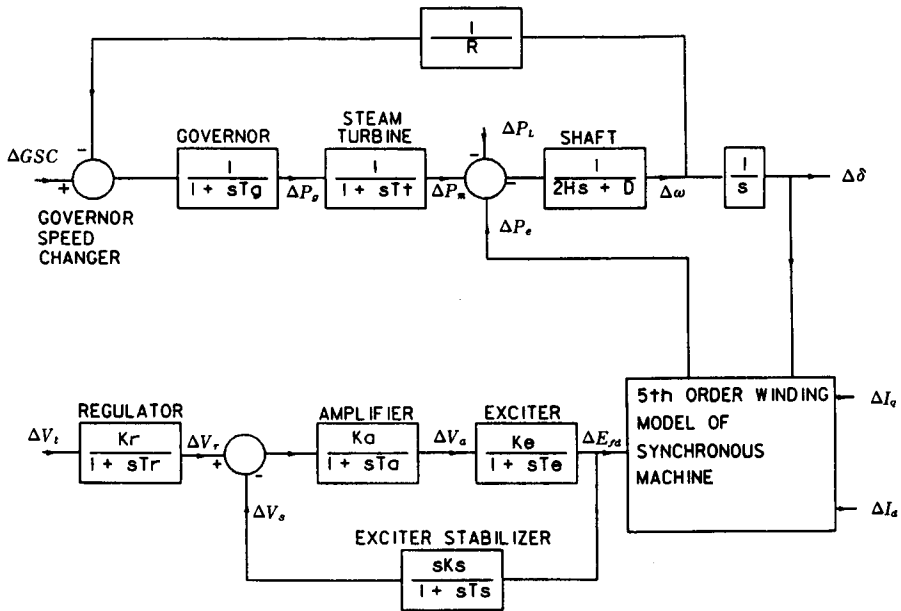

Figures 3.2 Single machine infinite bus block diagram.

The system parameters and operating point data are shown in Tables 3.1 through 3.4 and have been taken from<sup>9)</sup>. The one line diagram and block diagram of the system are shown in Figs. 3.1 and 3.2 respectively.

### 3. 2 Equivalency analysis





$$[B]^T = [0.0 \ 0.0 \ 0.0 \ 0.0 \ 0.0 \ -0.000503 \ 0.0 \ 0.0 \ 0.0 \ 0.0 \ 0.0 \ 0.0 \ 0.0 \ 0.0]$$

The outputs of this system were chosen to be  $I_d$ ,  $I_q$  and  $\delta$ . The corresponding C matrix is:

$$\begin{bmatrix} 1.0 & 0.0 & 0.0 & 0.0 & 0.0 & 0.0 & 0.0 & 0.0 & 0.0 & 0.0 & 0.0 & 0.0 & 0.0 & 0.0 \\ 0.0 & 0.0 & 0.0 & 1.0 & 0.0 & 0.0 & 0.0 & 0.0 & 0.0 & 0.0 & 0.0 & 0.0 & 0.0 & 0.0 \\ 0.0 & 0.0 & 0.0 & 0.0 & 0.0 & 0.0 & 1.0 & 0.0 & 0.0 & 0.0 & 0.0 & 0.0 & 0.0 & 0.0 \end{bmatrix}$$

The eigenvalues and input/output index of the system are given in Tables 3.5 and 3.6 respectively. The participation factor matrix is shown in Table 3.7. From analysis of the input/output index and the participation matrix, reduced order models were formulated

Table 3.5 Eigenvalues of the single machine system

Mode	Eigenvalue
1	-999.998
2	-27.053 + j376.257
3	-27.053 - j376.257
4	-26.280 + j39.754
5	-26.280 - j39.754
6	-38.182
7	-2.940 + j13.762
8	-2.940 - j13.762
9	-14.016
10	-4.000
11	-0.592 + j0.978
12	-0.592 - j0.978
13	-1.000

Table 3.6 Input/output index (100ths)

Mode	Eigenvalue	$I_d$	$I_q$	$\delta$
1	-999.998	0.000	0.000	0.000
2	-27.053 + j376.257	0.012	0.012	0.000
3	-27.053 - j376.257	0.012	0.012	0.000
4	-26.280 + j39.754	0.028	0.003	0.000
5	-26.280 - j39.754	0.028	0.003	0.000
6	-38.182	1.278	0.017	0.022
7	-2.940 + j13.762	64.159	66.405	22.057
8	-2.940 - j13.762	64.159	66.405	22.057
9	-14.016	32.354	76.284	7.867
10	-4.000	0.002	0.000	0.000
11	-0.592 + j0.978	32.617	11.171	15.718
12	-0.592 - j0.978	32.617	11.171	15.718
13	-1.000	0.001	0.000	0.000

as shown in Table 3.8. The reduced order models' maximum errors are shown in Table 3.9.

Table 3.7 Participation matrix

Mode	$I_d$	$I_F$	$I_P$	$I_q$	$I_Q$	$\omega$	$\delta$	$V_r$	$V_s$	$V_a$	$E_{fd}$	$P_m$	$P_g$
1	0.00	0.00	0.00	0.00	0.00	0.00	0.00	1.00	0.00	0.00	0.00	0.00	0.00
2	2.87	0.86	1.52	2.73	2.23	0.00	0.00	0.00	0.00	0.00	0.00	0.00	0.00
3	2.87	0.86	1.52	2.73	2.23	0.00	0.00	0.00	0.00	0.00	0.00	0.00	0.00
4	0.04	0.17	0.17	0.00	0.00	0.00	0.00	0.00	0.60	0.59	0.01	0.00	0.00
5	0.04	0.17	0.17	0.00	0.00	0.00	0.00	0.00	0.60	0.59	0.01	0.00	0.00
6	0.57	1.73	3.31	0.00	0.00	0.01	0.01	0.00	0.02	0.01	0.02	0.00	0.00
7	1.07	0.98	0.24	0.87	0.89	0.61	0.61	0.00	0.01	0.00	0.01	0.00	0.00
8	1.07	0.98	0.24	0.87	0.89	0.61	0.61	0.00	0.01	0.00	0.01	0.00	0.00
9	0.50	0.56	0.04	4.18	5.58	0.22	0.21	0.00	0.02	0.00	0.02	0.00	0.00
10	0.00	0.00	0.00	0.00	0.00	0.00	0.00	0.00	0.00	0.00	0.00	0.00	1.00
11	0.98	1.46	0.22	0.03	0.01	0.00	0.00	0.00	0.29	0.00	0.50	0.00	0.00
12	0.98	1.46	0.22	0.03	0.01	0.00	0.00	0.00	0.29	0.00	0.50	0.00	0.00
13	0.00	0.00	0.00	0.00	0.00	0.00	0.00	0.00	0.00	0.00	0.00	1.00	0.00

Table 3.8 Reduced order models of single machine system

Model order	Retained modes	Retained state var.	Outputs
2	7,8	$I_d, \delta$	$I_d, \delta$
3	7,8,9	$I_d, I_q, \delta$	$I_d, I_q, \delta$
4	7,8,11,12	$I_d, I_F, I_q, \delta$	$I_d, \delta$
5	7,8,9,11,12	$I_d, I_F, I_q, \delta, E_{fd}$	$I_d, I_q, \delta$

Table 3.9 Maximum p. u. error (100ths)  $\Delta P_L=1\%$ 

Model order	$I_d$	$I_q$	$\delta$
2	1.9790	1.9735	0.7865
3	1.3319	0.4477	0.6292
4	0.6743	1.5266	0.1578
5	0.0272	0.0009	0.0004

#### 4. Discussion of results

From Table 3.9 it is observed that as the order of the reduced order models of the system decrease the model accuracy also decreases. The only exception is the accuracy of output  $I_q$  when changing from a 4th order model to a 3rd order model. This is due to

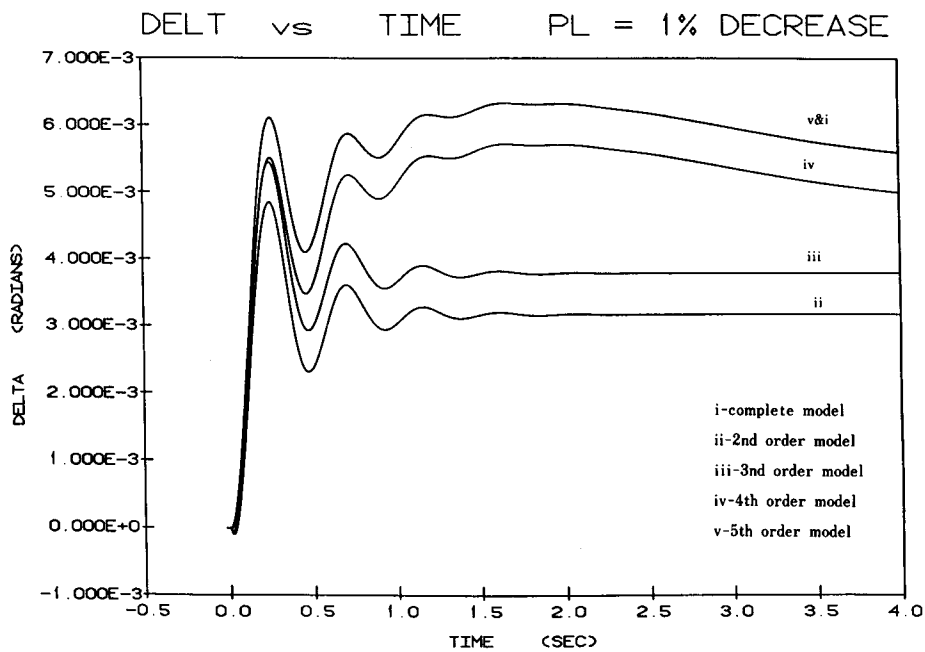

Figures 3.3 Rotor angle.

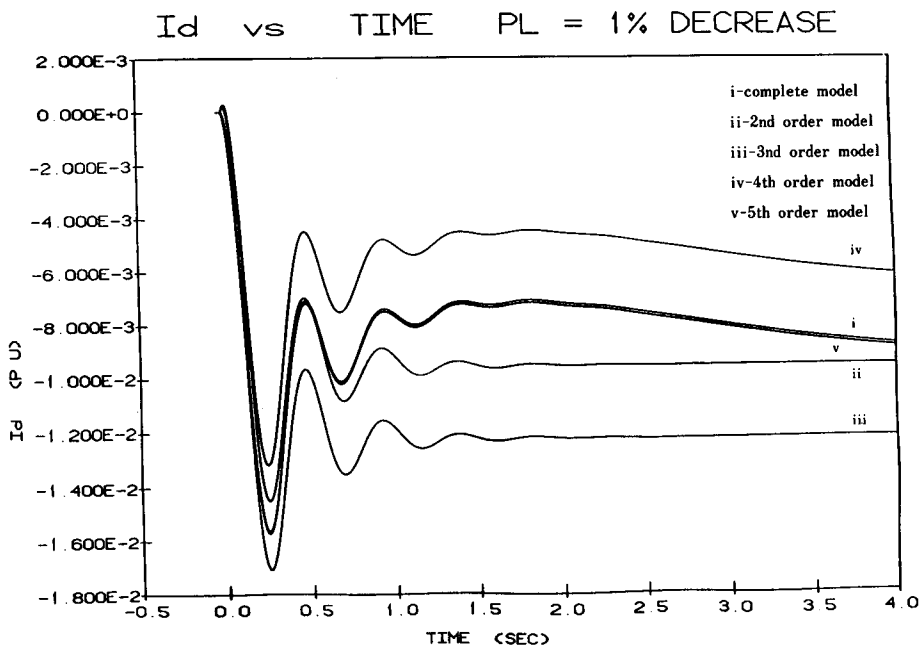

Figures 3.4 Direct-axis current.

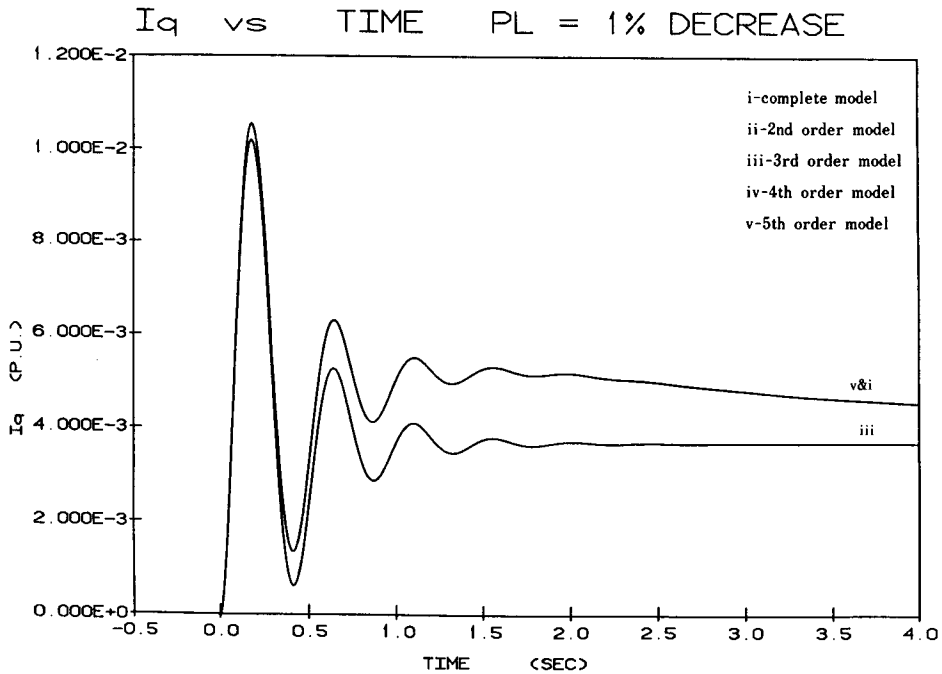

Figures 3.5 Quadrature-axis current.

the large participation of mode 9 in output  $I_q$ , as illustrated in Table 3.6, which is excluded in the 4th order model but included in the 3rd order model. From Table 3.9 it is also evident that a 5th order model will yield an almost identical response as compared with the complete model. The maximum error of the outputs  $I_d$ ,  $I_q$  and  $\delta$  will not exceed .0272 p. u. times the percent change in PL. Simulations of the reduced order models in Table 3.8 for a 1% step change in load power are shown in Figs. 3.3 through 3.5.

Figure 3.3 depicts the response of the power angle  $\delta$  to a 1% step change in load power. It is observed that the complete model and 5th order model yield an identical plot. The transient response of the 4th order model is also similar to the complete model, yet the steady state error increases slightly due to the neglect of the real mode 9. The transient and steady state error increase significantly when the mode pair (11,12) is neglected in the 2nd and 3rd order models. This is to be expected since complex mode pairs have complex input/output indexes, which in general affect both the transient and steady state error. The real part of the input/output index gives an indication of the error during the steady state part of the response, while the imaginary part is an indication of the error during the transient part of the response.

Figure 3.4 depicts the response of the direct-axis current  $I_d$  to a 1% step change in load power. The plots of the 5th order and complete model are almost identical. The

small steady state error is due to the neglect of the real mode 6. The 2nd order model transient response is also similar to the complete model, but exhibits some steady state error. The addition of modes to form the 3rd and 4th order models results in less accurate models than the 2nd order model. This can be somewhat intuitively explained by analyzing the real and imaginary parts of the eigenvalues in conjunction with the input/output index. However, in larger power systems, this type of analysis will not be practical, and simulations of the most accurate reduced order models, as suggested by the error analysis, may be required in order to select the most accurate and efficient model.

Figure 3.5 depicts the response of the quadrature-axis current  $I_q$  to a 1% step change in load power. Here again, as in the  $\delta$  plot, the 5th order model and complete model yield an identical response. The transient response of the third order model is also similar to the complete model, but it exhibits a slight steady state error. Only the 3rd and 5th order models were considered because neglect of the real mode 9 produced a large steady state error in the 2nd and 4th order models, as illustrated in Table 3.9.

The previous results were obtained using the input/output index in conjunction with the participation factor matrix to identify the retained modes and their related state variables for Davison's method of system reduction. The participation matrix accurately identified the state variables that were strongly related to the retained modes, so that, the desired reduced order modes could be formulated via Davison's method. In all but one of the reduced order models formulated in this study system, the retained state variables could be selected by a computer program which selects a state variable for each retained mode by the following algorithm.

- 1) First, select a state variable, which has not already been retained, with the largest participation factor with respect to the retained mode.
- 2) Secondly, compare the value of this participation factor with all the other participation factors corresponding to the selected state variable and the retained modes. If any of the participation factors is larger and is a maximum value with respect to another retained mode, then select a new state variable with the next largest participation factor and repeat the above process.
- 3) Otherwise, the state variable identified is retained and the algorithm is applied to the next retained mode.

The only case where the algorithm failed was in formulating the 5th order model. The state variables chosen by the algorithm for the 5th order model were  $I_d$ ,  $I_q$ ,  $I_Q$ ,  $\delta$  and  $I_F$ . Application of Davison's method with these retained state variables resulted in the formation of an erroneous reduced order model. This outcome is often the result of selecting too many similar type variables as suggested by Davison. When  $I_F$  was replaced by  $E_{fd}$  in the retained state vector, Davison's method formulated an accurate re-

duced order model. The single machine system allowed only the state variable selection algorithm to be evaluated on a few simple cases. This algorithm will be further evaluated on a multimachine system, where the need for an efficient state variable selection technique becomes increasingly important.

The single machine system was also analyzed to determine the effects that changes in the loading and system parameters would have on the reduction technique. Although the study was not exhaustive, the results provided a basis for the following observation.

The effect of changes in both the system loading and parameters slightly affected the participation of certain modes (associated with the sub-assemblies of the system) in the system outputs, but did not alter the order of reduction necessary to form accurate reduced models. For example, a faster AVR and exciter subsystem increased the participation of the mode pair related to the AVR and exciter in the outputs, but did not affect the order of reduction necessary for an accurate reduced model. A 5th order model was found to be highly accurate regardless of loading or parameter changes.

The single machine system was also analyzed to investigate the possibility of combining reduced order models of single machines in a multimachine system as suggested by Altalib and Krause, and to investigate the possibility of extending the reduction technique to form a non-linear model. The primary reason the combination of reduced order models was considered is due to the large amount of computation involved in the reduction process. By reducing single machines separately in a multimachine system considerable computer time savings could be realized. Also, the calculation of accurate eigenvalues and eigenvectors, the basis of the reduction technique, becomes increasingly difficult as the size of the system increases.

To investigate the possibility of combining reduced order models, the single machine system was analyzed with the terminal voltage as an input and  $I_d$ ,  $I_q$  and  $\delta$  as outputs. Reduced order models formed in this way could then be coupled to the system through the transmission equations. From analysis of the input/output index of this system it was evident that the proposed method was not practical. With  $V_d$  and  $V_q$  as inputs, the single machine system could not be reduced to an acceptable order that still maintained accuracy with respect to the complete model. Altalib and Krause were able to combine the reduced order models of two machines and retain the dominant eigenvalues of the rotor oscillations because the only outputs of interest were the rotor angles. The application of the reduction technique to form a non-linear model was also not practical since the linear portion of the model required for the non-linear swing equation could not be reduced to an acceptable level.

From the previous discussion it is evident that the reduction technique has limited applications, especially as the number of input/output constraints increase. It is also evident that the proposed method of system reduction may be well suited for determining

equivalents of an external system, where the number of inputs and outputs will be small compared with the size of the system state vector.

The authors would like to thank Mr John O. Leana who helped us as a research assistant.

### References

- 1) Davison, E. J. "A Method for Simplifying Linear Dynamic Systems", IEEE Trans. on Automatic Control, Vol. AC-11, No. 1, January 1966.
- 2) Undrill, J. M. "Dynamic Stability Calculations for an Arbitrary Number of Interconnected Synchronous Machines", IEEE Trans. Vol. PAS-87, No. 3, March 1968.
- 3) Undrill, J. M. and Turner, A. E. "Construction of Power System Electromechanical Equivalents by Modal Analysis", IEEE Trans., Vol. PAS-90, September/October 1971.
- 4) Altalib, H. Y. and Krause, P. C. "Dynamic Equivalents by Combination of Reduced-order Models of System Components", IEEE Trans., Vol. PAS-95, No. 5, September/October 1976.
- 5) Kuppurajula, A. and Elangovan, S. "Simplified Power System Models for Dynamic Stability Studies", IEEE Trans., Vol. PAS-90, No. 1, January/February 1971.
- 6) Perez-Arriaga, Verghese and Schweppe "Selective Modal Analysis with Applications to Electrical Power Systems, Part 1 : Heuristic Introduction", IEEE Trans., Vol. PAS-101, No. 9, September 1982.
- 7) Perez-Arriaga, Verghese and Schweppe "Selective Modal Analysis with Applications to Electrical Power Systems, Part 2 : The Dynamic Stability Problem", IEEE Trans., Vol. PAS-101, No. 9, September 1982.
- 8) Castro-Leon, E. "Modal Dynamic Equivalents in Power System Modeling and Simulations", Ph.D. Thesis, School of Electrical Engineering, Purdue University, USA, May 1980.
- 9) Ahmed, G. S., and Abdel-Magid, Y. L. "Reduced-order Models for the Dynamic Control of Power Plants Based on Controllability and Observability", IEE Proceedings, Vol. 134 Pt C, No. 4, July 1987.
- 10) IEEE Committee Report, "Computer Representations of Excitation Systems", IEEE Trans., Vol. PAS-87, No. 6, June 1968.
- 11) IEEE Committee Report, "Dynamic Models for Steam and Hydro Turbines in Power System Studies", IEEE Trans., Vol. PAS-87, No. 6, June 1973.

### Nomenclature

- $I_q$  : quadrature-axis current  
 $I_d$  : direct-axis current  
 $I_Q$  : quadrature-axis damper winding current  
 $I_D$  : direct-axis damper winding current  
 $I_F$  : field current  
 $\omega$  : rotor angle frequency  
 $E_{fd}$  : output voltage of exciter  
 $V_a$  : amplifier voltage  
 $V_r$  : regulator voltage  
 $V_s$  : exciter-stabilizer voltage



$P_m$  : output power of turbine  
 $P_g$  : output power of governor  
 $P_l$  : load power  
 $\delta$  : power angle  
 $H$  : inertia constant  
 $R$  : steady-state speed regulation  
 $T_g$  : governor time constant  
 $T_r$  : AVR time constant  
 $T_t$  : steam-turbine time constant  
 $T_a$  : amplifier time constant  
 $T_s$  : exciter-stabilizer time constant  
 $T_e$  : exciter time constant  
 $K_e$  : exciter gain  
 $K_r$  : AVR gain  
 $K_a$  : amplifier gain  
 $K_s$  : exciter-stabilizer gain  
 $\lambda$  : eigenvalue (mode)  
 $X$  : state vector  
 $A$  : plant matrix  
 $B$  : input matrix  
 $Y$  : output vector  
 $C$  : output matrix  
 $D$  : output matrix  
 $T$  : input/output index  
 $P$  : participation factor matrix  
 $M$  : right eigenvector matrix  
 $N$  : left eigenvector matrix  
 $U$  : input vector