



TITLE:

# Development of Simulator with Artificial Intelligence on Secondary Power System Operation

AUTHOR(S):

KAKIMOTO, Naoto; EZURE, Syoichiro; HAYASHI, Muneaki

---

CITATION:

KAKIMOTO, Naoto ...[et al]. Development of Simulator with Artificial Intelligence on Secondary Power System Operation. Memoirs of the Faculty of Engineering, Kyoto University 1988, 50(3): 129-153

ISSUE DATE:

1988-09-10

URL:

<http://hdl.handle.net/2433/281375>

RIGHT:

# Development of Simulator with Artificial Intelligence on Secondary Power System Operation

by

Naoto KAKIMOTO, Syoichiro EZURE and Muneaki HAYASHI

(Received December 26, 1987)

## Abstract

Centralized control from a control center is popular in secondary power systems. However, as operating systems are modernized and automated, operators rarely have opportunities to experience various situations. On the other hand, operators are expected to quickly cope with any situation once an accident happens. In this paper, artificial intelligence has been applied to the training of a secondary power system operation. The developed system has simulation, training, and inquiry modes. In the training mode, it helps operators train in restoring power systems. If an operator succeeds in restoration, the system evaluates executed operations. If he fails, the system generates and presents an example of restoration operations. These functions have been realized by expert systems of a production rule type. Methods of automatically generating restoration process and of evaluating executed operations have been described in detail. Restoration operations are generated so as to restore blackout load buses one by one. The used rules are very simple, and are easy for operators to understand. On an operator's request, it explains how each operation is generated. Evaluation is made on items such as new blackouts and overloads caused by executed operations. If any operations come under these items, then the system gives some warnings and corrections about them. The system was applied to an example power system, and its effectiveness was verified.

## 1. Introduction

Electric energy plays an important role in the present society because of generality and cleanness. A stable supply of electric energy is an important issue. For this purpose, the unmanned of power stations and substations were promoted as a step for total automatic control of power systems. One control center usually controls dozens of power stations or substations.

However, as operating systems are modernized and automated, operators rarely have opportunities to experience various situations (1) - (5). On the

other hand, they are expected to quickly cope with any situation once an accident happens (6) - (8). Each electric company lay stress on its education and improvement of training facilities and contents.

Training simulators are widely used to train operators in operating 1 : n centralized remote controllers. One simulator usually consists of a 1 : n centralized remote controller and a power system setting board. By generating various situations with the setting board, operators experience and learn operations in normal, emergency, and restoration states of power systems.

However, the usual simulators are electrically constructed analog simulators, so several problems remain in providing proper training environments. Firstly, it is not so flexible in changing power system configuration. Secondly, initial states are manually set, so it requires a long time, and reproduction of them is difficult. Thirdly, it needs man-to-man guidance by experienced instructors, so training efficiency for machine and human resources is low. The first two problems are solved by using digital computers for analog ones. For the third problem, one solution is found in knowledge engineering (9) - (15).

In this paper, a training simulator is proposed. It is an expert system which has knowledge about a power system operation and restoration. The system has two features. One is that it uses basic rules on operations, so its thought and guidance are close to those of human beings, and are easy to understand. The other is that the expert system was originally developed to support the judgement of human beings, and has an ability to explain its inference process. This ability is used to answer questions about operations, for example: Why is an operation required?, Why is an operation not allowed?, etc. Owing to these features, this system can provide an educational environment equal to that obtained by experienced instructors.

An outline of this system is first described in Chapter 2. The rules for generating restoration operations and those for evaluating operations made by operators, are explained in Chapters 3 and 4. On the way, several examples are shown to illustrate the system's behavior. In Chapter 5, some concluding remarks on this study are made, and the remaining problems are described.

## 2. Outline

### 2.1 System structure

Fig. 1 shows a structure of this system. There are four main parts in this system, namely, power system, simulator, solver and tutor. Detailed explanations of these parts are given as follows:

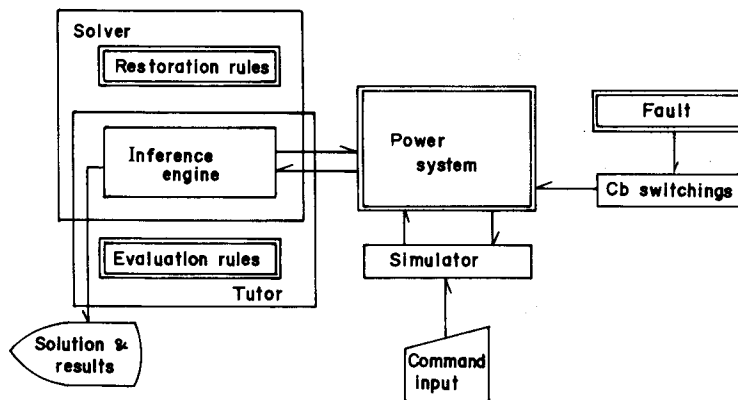

Fig. 1 Structure of training simulator.

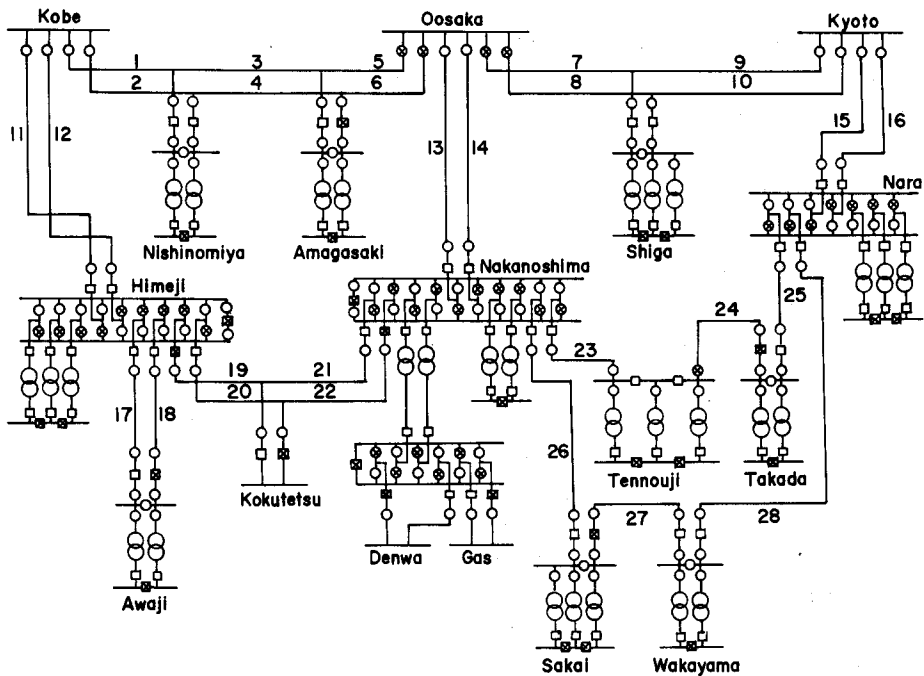

Fig. 2 Secondary power system.

(1) Power system

This part is data expressing a secondary power system shown in Fig. 2. There are 12 substations in the power system. The voltage levels are 77 kv, 22 kv, and 6.6 kv. Machines, such as transmission line, bus, transformer, circuit breaker, line switch, are treated as one unit, respectively. The power system is expressed by the connections of these machines. Data on each machine are all

written in a property list of Lisp. Changes in the power system state are expressed by changes of values in the property lists.

(2) Simulator

This part manages commands input by the operator, and obtains the state of the power system after the execution of the command. This part is written in Lisp.

(3) Solver

This part generates a series of operations to restore all blackout load buses in a given system state. This part forms an expert system based on a knowledge base consisting of restoration rules. An expert shell called Eshell is used in developing this expert system (16).

(4) Tutor

This part preserves all operations executed by an operator, and evaluates them. Also, this part forms another expert system consisting of operation rules.

By combining these parts well, this system operates in three specified modes as described in the following:

## 2.2 System behavior

This system has three modes, namely,

- (1) Simulation mode
- (2) Training mode
- (3) Inquiry mode

(1) Simulation mode

In the simulation mode, the system carries out each command in the same way as the actual 1:n centralized supervisory controller does, where available commands are

- SS-select : select a substation.
- SS-reset : release a substation.
- M-select : select a machine.
- M-reset : release a machine.
- ON : close a switch.
- OFF : open a switch.
- AM-convert : switch tap control of a transformer from manual to automatic and vice versa.
- UD-convert : change tap place of a transformer up and down.
- Cutoff : open and close distribution switches.
- Synchro : check synchronism at a circuit breaker.

Telchange : ask an operation of a non-remote control machine by telephone.

If an input command is feasible, then the system carries it out, and reports the result of the command to the operator. In this mode, the operator operates the controller by himself without any guidance.

### (2) Training mode

The training mode is the main part of the system, and it is closest to actual training circumstances. The system first asks an operator to restore a power system for one of some faults prepared in advance. If the operator could complete the restoration, the system evaluates the operations done by him. If not, the system generates and presents a model restoration process. By request, it explains reasons why an operation is generated. Thus, operators can train in an environment similar to simulator practices under the guidance of experienced instructors.

### (3) Inquiry mode

In the inquiry mode, an operator can request the system to do some job. The system generates a series of operations to do it, and presents them to the operator. The system explains each operation by the operator's request, again. The operator can learn many processes for shifting the power system from one state to another one, and he can get much knowledge on ordinary switch operations as well as restorative ones.

## **3. Generation of restoration operations**

The generation of restoration operations is done in the "solver" of Fig. 1. This part forms an expert system developed with Eshell. The rules are of the production type, and are grouped into several sets. The inference is done by chaining these rules forward with a blackboard (16).

### **3. 1 Design of blackboard**

The blackboard is a common data area. Results of the inference in one rule set is passed to another rule set through this common area. This section concretely describes how the blackboard is used in the solver.

Three levels called "component", "plan", and "operation" are used to generate restoration operations. The relations among them are shown in Fig. 3. There are several nodes in each level. The arrow in the figure denotes a link from one node to another node.

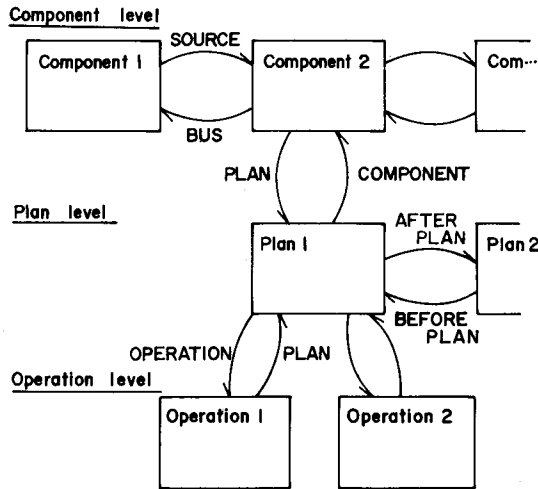

Fig. 3 Design of blackboard.

## (1) Component level

A node of this level has information about a component. The restoration proceeds by energizing components one after another. Only buses and transmission lines are considered as components. Transformers, circuit breakers, and line switches are not treated as components. Seven attributes are written in one node.

name	: name of component
id	: kind of component (load bus, receiving bus, line)
charge	: state of charging (T if charged)
route	: route to a component pointed by link "bus"
connected	: state of connection of "route" (T if connected)
connect	: connectivity of "route" (T if connectable)
because	: reason why this component is chosen as a source of restoration.

There are four links. A link points to a node where necessary information is written.

bus	: component which is restored by this component.
source	: component which restores this component.
plan	: plan which connects this component to the bus.
why	: node where more detailed explanation is stored.

## (2) Plan level

In a node of this level, a plan for connecting one component to another

component is written. One component is related with several operations by a plan. It has one attribute, i. e.,

because : reason why this plan is generated.

It has five links.

- beforeplan : plan which is executed before this plan.
- afterplan : plan which is executed after this plan.
- component : component which is used as restoration source by this plan.
- operation : operations which are executed under this plan.
- why : node where more detailed explanation is stored.

### (3) Operation level

In a node of this level, an operation is written. It has two attributes, i. e.,

- operation : operation and its target machine.
- because : reason why this operation is necessary.

It has two links.

- plan : plan under which this operation is executed.
- why : node where more detailed explanation is stored.

These nodes are generated in the restoration process.

## 3. 2 Restoration policy

The solver automatically generates restoration operations by referring to restoration rules. The rules are chosen to meet three basic restoration policies (10), (11), i. e.,

- (1) Power systems must be restored to their prefault states as closely as possible.
- (2) Overloads must be prevented from occurring.
- (3) Restoration must be completed as fast as possible.

Power systems are usually operated at planned states. These are normal states and are designed to satisfy all operational restrictions. When power systems are disturbed by faults, it should be first tried to place them back to their original states as close as possible. Rules to meet this policy are given high priority.

In restoration operations, it is necessary to take several restrictions such as stabilities, overloads, and overvoltages into consideration. Among them, overloads are most popular in secondary power systems. Overloads often occur and bring further trouble. Some measures must be prepared to resolve overloads.

Loadflow calculation is executed in every switch operation to determine



system states. If an executed operation causes any overloads, then it must be cancelled. Consequently, two load flow calculations are wasted in vain. It is not desirable to do such inferences as denied by operational restrictions.

It is also important for a rapid restoration to minimize the number of operations. Unnecessary operations should be avoided as much as possible.

### 3.3 Restoration Process

Fig. 4 shows a process of generating restoration operations. Blackout load buses are restored one by one through four steps. One blackout load bus is first chosen, and then its restoration source is sought. If a source is found, operations necessary for connecting them are generated. The obtained operations are checked to know whether they cause any overloads or not. If there is an overload, then some measures are applied to resolve it. These steps are iterated till all blackout load buses are restored or no rules are applicable.

Fig. 5 shows how a restoration source is searched for a blackout load bus. The depth-first search algorithm is used (17). Let  $c_1$  be a blackout load bus.

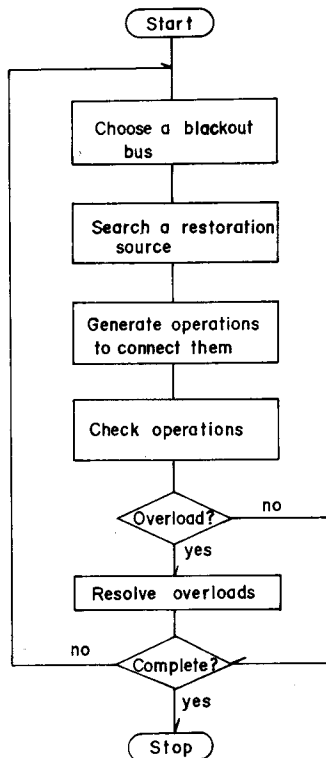

Fig. 4 Restoration process.

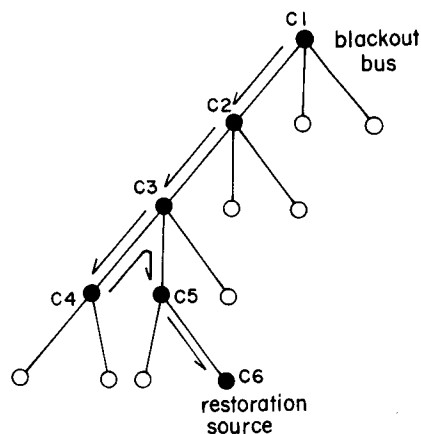

Fig. 5 Search for restoration source.

One component  $c_2$  is chosen among all the components adjoining  $c_1$ . Rules are used to choose one component among several components.

If a chosen component is charged, then it becomes a restoration source of the blackout bus. If not, this time a new component  $c_3$  is chosen among all the buses adjoining  $c_2$ . This search is continued till a restoration source is found.

If a chosen component, e. g.,  $c_4$  is not energized, and if all the components adjoining this component do not satisfy any rule, then the search is traced back to  $c_3$ . One component is chosen among all the components adjoining this component, where  $c_4$  is excepted.

If a restoration path is found, all components on the path are energized one by one from the restoration source. One plan and the accompanying operations are generated as one component which is energized.

Overloads are resolved by a parallel operation of transformers or a partial load cut. A parallel operation is first tried. If no path for a parallel operation is found, or if an overload still remains after the parallel operation, then some load at the blackout bus is partially cut.

### **3. 4 Rules for restoration**

Restoration operations are generated mainly by referring to five groups of rules. One group is used to choose a blackout load bus. Two groups are used to search for a restoration source of a chosen blackout bus. One is used to generate plans and operations to connect a blackout bus and a restoration source. One is used to check and resolve overloads. In this section, detailed explanations about them are described.

#### **(1) Choice of blackout bus**

There are two rules in this group. These rules are used to determine a blackout load bus to restore.

1. If there are some blackout buses in the substation where restoration is proceeding, then restore one of them next.
2. If no blackout bus remains in the substation where restoration is proceeding, then restore another substation next.

It is intended to restore blackout buses in one substation as continuously as possible. If a blackout bus is chosen, one node is generated in the component level of the blackboard.

Fig. 6 shows a Tennouji substation. Circuit breakers 510, 520, 220 have been opened because of a fault on transformer tr02. Tr02 and tr03 have stopped power supplies to bus02 and bus03. Bus02 and then bus03 are restored according to rule 1.

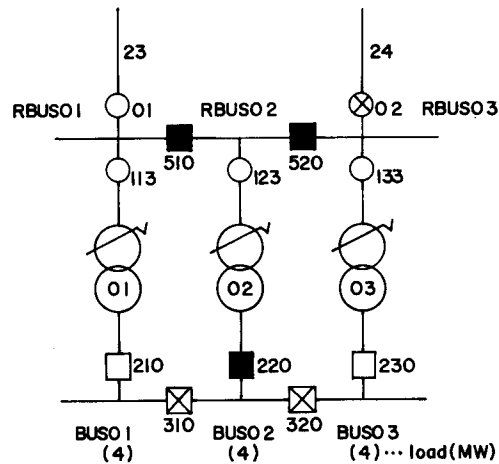

Fig. 6 State of switches after a fault.

## (2) Search for restoration source-1

There are 9 rules in this group. These rules are used to choose a component among all the components adjoining a load bus.

1. Generate nodes for all the adjoining components, and write data in them.
2. If a component is a receiving bus or transmission line, connected, but not charged, then choose it.
3. If a component is a load bus, connected, but not charged, then choose it.
4. If a component is a receiving bus or transmission line, not connected but connectable, and if it is charged, then choose it.
5. If a component is a receiving bus or transmission line, not connected but connectable, and if it is not charged, then choose it.
6. If a component is a load bus, not connected but connectable, and if it is charged, then choose it.
7. If a component is a load bus, not connected but connectable, and if it is not charged, then choose it.
8. If no component satisfies rules 2, ..., 7, then trace back to a component pointed by link "bus".
9. If no component satisfies rules 2, ..., 8, then go to the restoration of another blackout bus.

Consider restoring bus 02 of Fig. 6, first. Three components are adjoining this load bus, that is, bus 01, bus 03, and rbus 02. These components are considered as candidates for a restoration source of bus 02.

Rule 1 is first applied. Three nodes are newly generated on the blackboard. Information such as route to bus 02, connection state, connectivity, is written as

attributes of these nodes. A node corresponding to bus 01 is expressed as follows;

```

Node name <component 2 >
NAME      = (Tennouji-bus 01)
ID        = (load bus)
CHARGE    = (T)
ROUTE     = (Tennouji-bus 02 Tennouji-cb 310 Tennouji-bus 01)
CONNECTED = (NIL)
CONNECT   = (T)
BUS       = (component 1 )
    
```

The attributes show that bus 01 is a load bus, that it is not connected but connectable, and that it is charged,.... Similar data on rbus 02 and bus 03 are written in other nodes, too.

Rules 2, . . . ,7 are next applied in sequence to these adjoining components, as shown in Fig. 7. The number of the rule indicates the order of priority. Bus 01 satisfies rule 6, and bus 03 satisfies rule 7, for example. In this case, bus 01 is chosen as a restoration source. Rbus 02 does not satisfy any of the rules 2, . . . ,7 because it is not allowed to close cb 220. Namely, rbus 02 is not connectable. Cb 310 is closed to connect bus 01 and bus 02, as shown in Fig. 8. There is no overload, so the restoration of bus 02 is completed by this operation. Rule (1) -1 directs the restoring of bus 03 next.

The order of priority has been determined according to the restoration

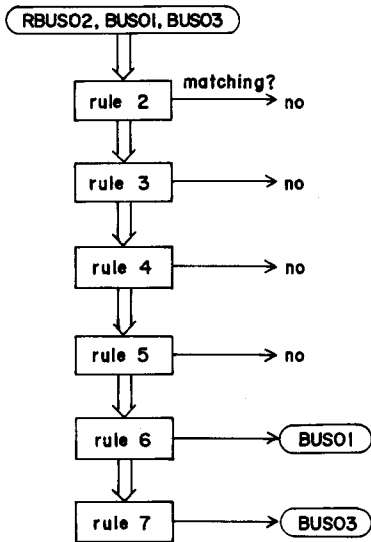

Fig. 7 Rule matching.

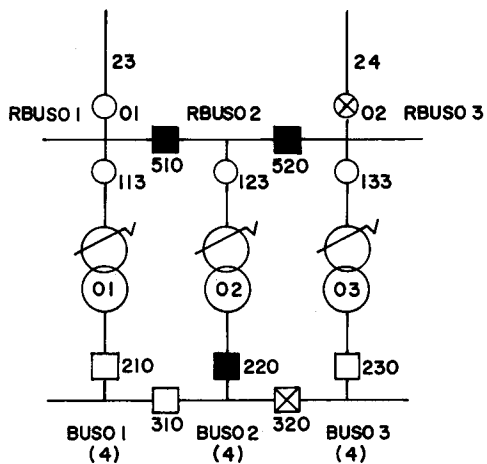

Fig. 8 Restoration through a load bus.

policies. Rules 2, . . . ,7 are classified into three subgroups as follows.

Rules 2 and 3 first represent restoration policy 1. Components which satisfy these rules are given priority over other components. Namely, a connected component is chosen as a source in order to place the power system back to its pre-fault state as closely as possible.

Rules 4 and 5 represent restoration policy 2. Transformers are checked for overload. Each transformer exists between a load bus and a receiving bus. If a load bus is chosen as a restoration source of another load bus, more than two load buses are supplied with one transformer. The possibility of the transformer being overloaded accordingly increases. In order to avoid this situation, receiving buses are given higher priority than load buses as a restoration source. This idea also applies to rules 2 and 3.

As an example, consider the restoring of bus 03 of Fig. 8. Two buses, namely, rbus 03 and bus 02 are adjoining this bus. Rbus 03 is a receiving bus, and satisfies rule 5. On the other hand, bus 02 is a load bus, and satisfies rule 6. According to the order of priority, rbus 03 is chosen as a restoration bus of bus 03.

Rules 6 and 7 are rules for load buses. Rule 6 chooses a charged load bus, and rule 7 chooses a noncharged one. Namely, a charged load bus is given priority to a non-charged one. This priority serves to reduce the number of operations, and therefore represents restoration policy 3. This idea applies to rules 4 and 5, too.

Rules 8 and 9 are applied when all of rules 2, . . . ,7 are not applicable.

### (3) Search for restoration source-2

There are 8 rules in this group. These rules are used to choose a component among all the components adjoining a receiving bus or a transmission line.

1. Generate nodes for all adjoining components, and write data in them.
2. If a component is a transmission line, connected but not charged, then choose it.
3. If a component is a receiving bus, connected but not charged, then choose it.
4. If a component is a receiving bus, not connected but connectable, and if it is charged, then choose it.
5. If a component is a receiving bus, not connected but connectable, and if it is not charged, then choose it.
6. If a component is a transmission line, not connected but connectable, and if it is charged, then choose it.
7. If a component is a transmission line, not connected but connectable, and

if it is not charged, then choose it.

8. If no component satisfies rules 2, . . . , 7, then trace back to a component pointed by link "bus".

Consider restoring the receiving bus rbus 03 of Fig. 8, this time. Three components are adjoining this receiving bus, i. e., bus 03, rbus 02, and line 24. Bus 03 is not considered as a restoration source, however, because it is energized from rbus 03.

Rule 1 is first applied as in (2) . Two component nodes are newly generated for rbus 02 and line 24. Rules 2, . . . , 7 are applied to these components. Line 24 is a transmission line and satisfies rule 7. Rbus 02 is a receiving bus, but it does satisfy any rule. Cb 520 is not allowed to close because of a fault on tr 02, and rbus 02 is not connectable to rbus 03. Thus, line 24 is chosen as a restoration source of rbus 03, and then line switch ls 02 is closed to connect them.

Rules 2, . . . , 7 are classified into three subgroups as in (2) . Rules 2 and 3 represent restoration policy 1, and are applied to connected components.

Rules 4 and 5 are applied to receiving buses while rules 6 and 7 are applied to transmission lines. Namely, receiving buses are given priority over transmission lines. This priority has been introduced to complete restoration in one substation as much as possible, and to have only one power source.

Rules 6 and 7 are applied to transmission lines. If restoration is not completed only by connecting receiving buses, then a transmission line is chosen as a restoration source.

In each subgroup, a charged component is given priority to a noncharged component. This priority represents restoration policy 3.

#### (4) Connection between restoration bus and source

There is only one rule in this group. The rule is used to energize one component from a restoration source.

1. Close all open switches on a route from a restoration source to a component under restoration. If additional operations are necessary, then add them.

All open switches on the route are first searched. Each switch is examined to know whether there is no problem in closing it. This check is done by a program written in Lisp. There are three cases where it is not allowed to directly close a switch.

- 1) Different power systems are connected by closing a switch. Whether it is allowed to connect different systems by the switch, and whether two systems are synchronized enough to connect them, must be checked be-

forehand.

- 2) A current flows or stops by switching a line switch. It is necessary to open a circuit breaker on the source side of the switch first.
- 3) A switch is interlocked by another switch. In this case, it is necessary to release the interlock first.

As an example, consider the closing of ls02 in Fig.8. Assume ls02 is interlocked by ls133. Two operations are added as follows to release the interlock.

- Operation 1 : Off Tennouji-ls 133
- Operation 2 : On Tennouji-ls 02
- Operation 3 : On Tennouji-ls 133
- Operation 4 : On Takada-cb 01

Line switch ls133 is first opened, ls02 is closed next, and lastly ls133 is closed again. The states of the switches after these operations are shown in Fig.9. Two operations of ls133 have been added to one operation of ls02. Operation 4 is done to energize rbus03 from the Takada substation.

(5) Check of restoration operations

If a series of operations are obtained to restore a blackout bus, then they are executed to see if any overloaded transformer will appear or not. Depending upon its result, several measures are applied. There are 5 rules in this group, namely,

1. If there is no blackout bus, and if there is no overloaded transformer, then end the restoration.

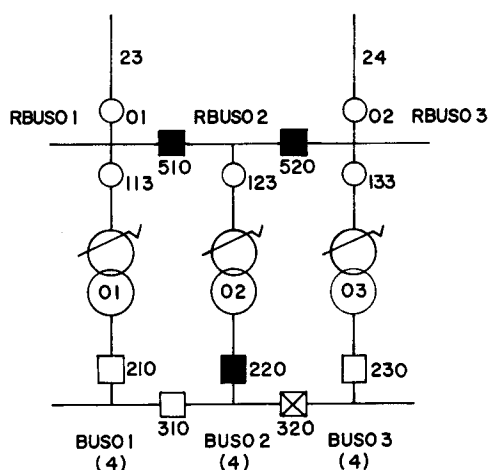

Fig. 9 Power supply from another power source.

2. If there is a blackout bus, and if there is no overloaded transformer, then go to restore one of the blackout buses.
3. If there is an overloaded transformer, then try parallel operation of transformers.
4. If an overload is not resolved by parallel operation, then cut off a part of the load.
5. If there is a partially restored bus, then try its complete restoration.

Rule 1 deals with cases where all blackout buses have been completely restored. For example, there are no blackout buses and no overloaded transformers in Fig. 9.

Rule 2 suggests restoring another blackout bus if there are any other blackout buses.

Rules 3, 4, and 5 deal with cases where some transformers are newly overloaded because of the executed operations. These rules suggest parallel operations of transformers or partial cuts of loads.

Fig. 10 shows a case where a parallel operation of transformers is done. Transformer tr 03 stops because of its fault. Bus 03 is a blackout bus. It seems to be restored by closing cb 320. However, this operation makes tr 01 overloaded. It supplies three buses whose total load is 12 Mva, while its capacity is only 10 Mva. Rule 3 suggests operating tr 02 in parallel with tr 01. The solver generates operations as follows;

- Operation 1 : on Tennouji-ls 123
- Operation 2 : on Tennouji-cb 220
- Operation 3 : on Tennouji-cb 320

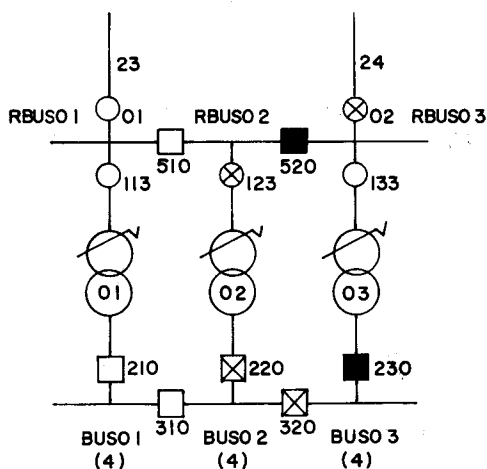

Fig. 10 State of switches after another fault.



Tr 02 is operated in parallel with tr 01, as shown in Fig. 11. The total capacity of the transformers is 20 Mva, so the overload of tr 01 is resolved. (Note : cb 310 should be opened soon because the parallel operation is temporarily used, and no overload appears if this operation is executed.)

Consider the restoration of bus 03 in Fig. 8, again, as an example of a case where the load cut is done. If it is not allowed to close ls 02 because of an operational restriction (Note : It is not usual to supply one substation from two different substations.), then bus 02 must be chosen as the restoration source of bus 03. Bus 03 is restored by closing cb 320. However, this operation makes tr 01 overloaded. It supplies three buses whose total load is 12 Mva.

Rule 3 suggests operating other transformers in parallel with tr 01, but neither tr 02 nor tr 03 are available. Hence, rule 4 is applied next, and some load at bus 03 is cut as follows ;

- Operation 1 : cutoff 2 Tennouji-bus 03
- Operation 2 : On Tennouji-cb 320

The load at bus 03 is reduced to 2 Mva by opening several distribution switches, and then cb 320 is closed, as shown in Fig. 12. Tr 01 is fully loaded.

Since bus 03 has not been completely restored, rule 5 directs restoring bus 03 completely. However, there is no other way to restore bus 03, so its complete restoration is given up according to rule (2) - 9.

### 3. 5 Explanation of restoration operations

This system has an explanation function. The system not only shows

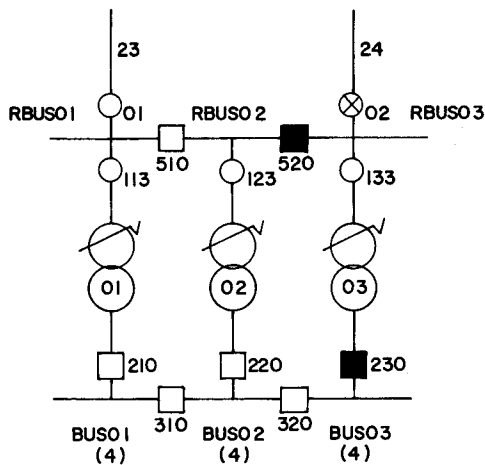

Fig. 11 Parallel operation of transformers.

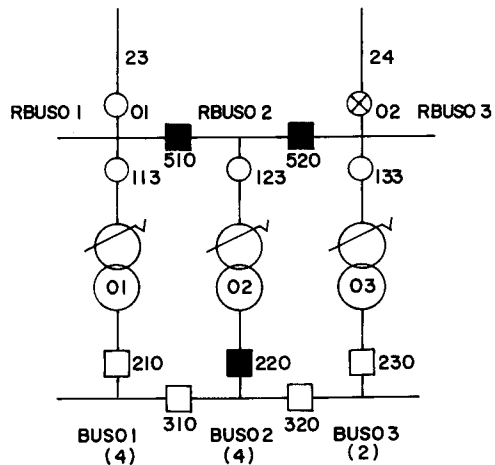

Fig. 12 Partial cut of load.

restoration operations, but also tells why each operation is required. It is an important function because this system aims to guide operators. Answering questions from operators leads to a reduction of misoperations.

In order to explain about restoration operations, all rules and reasons used to generate them must be preserved. The attribute "because" has been introduced in 3.1 for this purpose. Three types of reasons are written in the attribute.

- 1) Why was an operation added?  
e.g., Synchronism was checked at cb 520 to connect different systems.
- 2) Why was an operation done?  
e.g., Cb 210 was operated to connect bus 01 and rbus 01.
- 3) Why was a component chosen?  
e.g., Bus 01 was chosen as the restoration source of bus 02.

These reasons are written into the nodes of "operation", "plan", and "component" levels, respectively, while generating restoration operations.

If an operator requests an explanation about an operation, then a reason in an operation node is first shown. A reason of this level is the first type. However, this type of reason is written only when an operation is added to execute another operation, for example, to release an interlock. If no reason is in the node, then its "why" link is traced to get a plan node as shown in Fig.13. A reason of the second type is then shown. For more requests, its "why" link is traced further to get a component node. A reason of the third type is shown. This process is iterated for every request till no node is obtained.

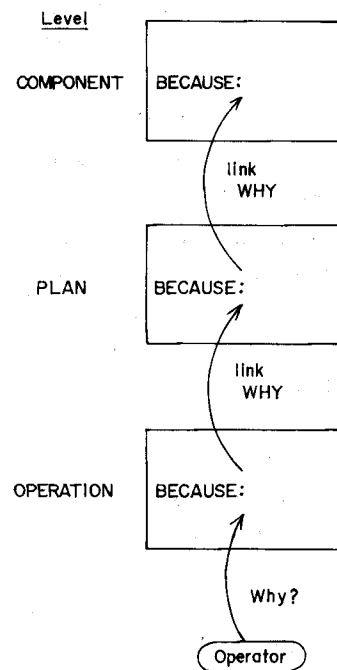

Fig.13 Explanation process.

Fig. 6 was a case where tr 02 stopped because of its fault. Cb 510, cb 220, and cb 520 were opened. The solver generated the following operations to restore blackout buses bus 02 and bus 03.

- Operation 1 : On Tennouji-cb 310
- Operation 2 : Off Tennouji-ls 133
- Operation 3 : On Tennouji-ls 02
- Operation 4 : On Tennouji-ls 133
- Operation 5 : On Takada-cb 01

The operator had some questions about these operations, and asked for an explanation about them. The system explains as follows;

```

***** Explanation *****
>2 Tennouji-ls 02 was interlocked by ..... operation level
   Tennouji-ls 133, so it was released.
>3 Tennouji-ls 02 was closed to connect ..... plan level
   line 24 and Tennouji-rbus 03.
>c Line 24 was chosen as a restoration ..... component level
   source of Tennouji-rbus 03.
   →rule (3) -6
>c Tennouji-rbus 03 was chosen as the ..... component level
   restoration source of Tennouji-bus 03.
   →rule (2) -2
>c no explanation.

```

where ">" is a prompt. Following the prompt, the operator inputs "2" to ask about operation 2. Responding to this request, the system has shown one explanation in an operation node because this operation is an additional one. As for operation 3, the system has shown one explanation in a plan node. Responding to the "c"s, the system has shown two explanations in component nodes. However, for the last "c", it has shown that there is no more explanation.

### 3.6 Examples

Several examples are shown here to illustrate how the solver generates restoration operations.

#### (1) Example 1

Fig. 14 shows a case where transmission line 14 is ground-faulted. Because of this fault, cb 04 at the Nakanoshima substation is opened, and the power supplies to bus 01, bus 02, and gas are stopped.

By the operator's request, the solver generates a solution as follows;

Operation 1 : On Nakanoshima-cb 80

The solver begins the restoration with bus 01. Rbus 02 is first chosen among all the components adjoining bus 01 according to rule (2) -2. Then, rbus 01 is chosen as the restoration source of rbus 02 according to rule (3) -4. Cb 80 is closed to connect rbus 01 and rbus 02. Once rbus 02 is energized, all blackout buses are restored. This operation therefore completes all restorations.

#### (2) Example 2

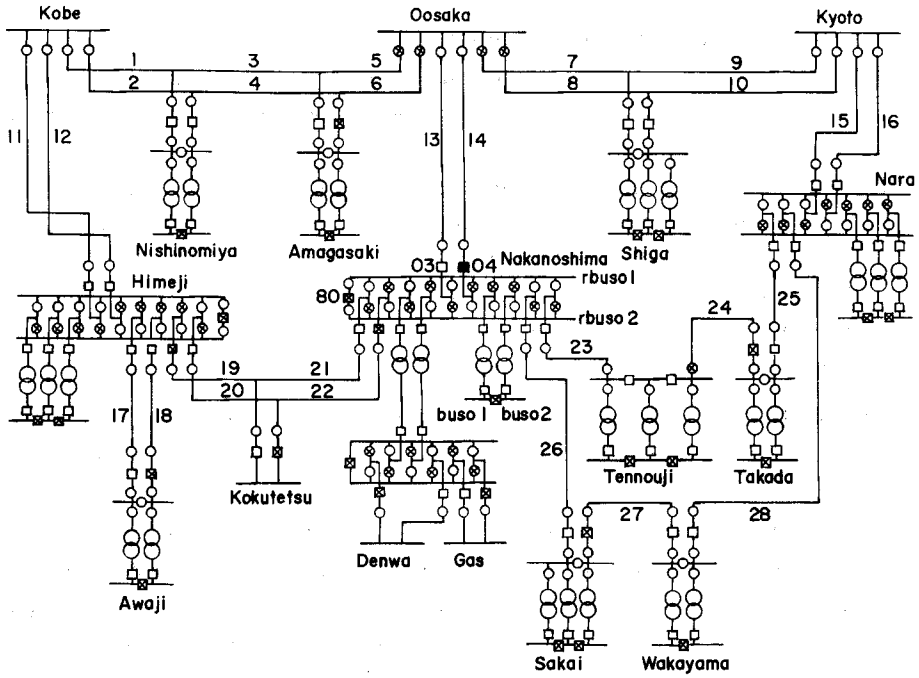

Fig. 14 Example of restoration—1.

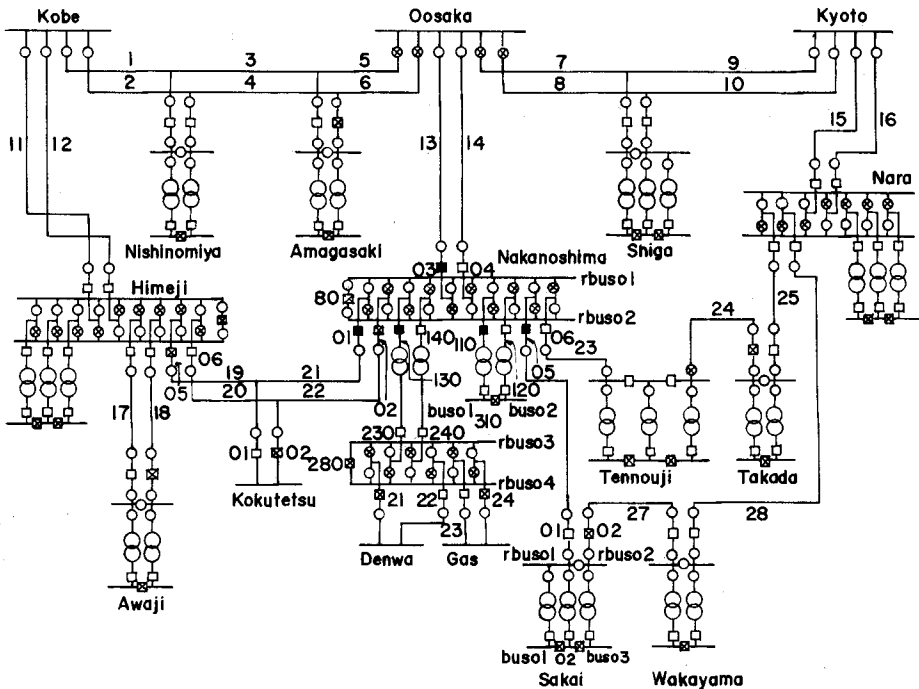

Fig. 15 Example of restoration—2.

Fig. 15 shows a case where a receiving bus is ground faulted. Due to a groundfault at rbus 01 in the Nakanoshima substation, cb 80, cb 01, cb 130, cb 03, cb 110, and cb 05 are all opened. It stops power supplies to bus 01, denwa, the Sakai and Kokutetsu substations.

It is not allowed to close cb 80 this time because it connects a sound system to the faulted bus. The solver generates a series of operations as follows;

Operation 1 : On Nakanoshima-cb 310

Operation 2 : On Nakanoshima-cb 280

Operation 3 : On Sakai-cb 02

Operation 4 : On Himeji-cb 05

The bus 01 of the Nakanoshima substation is first restored. Bus 02 is chosen as the restoration source of bus 01 according to rule (2) -6, and cb 310 is closed to connect them.

Denwa in the same substation is next restored. Rbus 03 is chosen among all the components adjoining denwa according to rule (2) -2, and rbus 04 is chosen as the restoration source of rbus 03 according to rule (3) -4. Cb 280 is closed to connect rbus 03 and rbus 04. By this operation, the restoration in the Nakanoshima substation is complete.

The solver begins to restore the Sakai substation. Bus 01 is restored. Rbus 01 is first chosen according to rule (2) -2, and then transmission line 26 is chosen according to rule (3) -2. However, there is no restoration source to energize line 26, so the line is discarded. The inference goes back to rbus 01.

As a source of rbus 01, rbus 02 is chosen this time according to rule (3) -3, and then line 27 is chosen as its source according to rule (3) -6. Cb 02 is closed to connect rbus 02 and line 27. By this operation, all buses in the Sakai substation are restored.

Similar inferences are made in the Kokutetsu substations, too, and the above operations are obtained.

## 4. Evaluation

Operations made by operators are evaluated by "tutor" in Fig. 1. This part forms an expert system, too. In this system, the blackboard is used to preserve a history of the operations.

### 4. 1 Design of blackboard

The tutor preserves all operations which change the state of the power

system, namely, on, off, cutoff, and telchange. There is one level called "check" on the blackboard, and one node is generated as one operation is done. Each node of this level has six attributes as follows;

Node name <check 2 >  
OPERATION = (On Tennouji-cb 310)  
BLACKOUT = (NIL)  
OVERLOAD = (Tennouji-tr 03 3)  
NECESSITY = (T)  
BEFORE = (check 1)  
AFTER = (check 3)

This node has been named as check 2. OPERATION is a pair of an operation and its target machine. The circuit breaker cb 310 of Tennouji substation has been closed. BLACKOUT is a list of load buses which newly have power cuts by this operation. NIL means that there is no new blackout bus. OVERLOAD is a list of newly overloaded machines and levels. The transformer tr 03 of Tennouji substation has been newly overloaded and its level is 3. NECESSITY shows whether this operation is necessary or not. T means that this operation is necessary. The AFTER and BEFORE points check nodes generated before and after this check node, respectively. Checks 1 and 3 have been done before and after this operation.

#### **4. 2 Items of evaluation**

Evaluation is made after an operator completes restorations of all blackout load buses. The operations are not necessarily optimum, but they are thought to be useful enough. The optimality of operations is not therefore evaluated in this system. The evaluation is made on the following 4 items;

- (1) Is there any new blackout load bus?
- (2) Is there any new overloaded machine?
- (3) Is the operation necessary?
- (4) Is the order of operations correct?

Firstly, operations which newly bring blackout buses should be avoided. For such operations, the tutor shows blackout buses, and gives some warnings to the operator.

Secondly, restoration should be executed without generating overloaded machines because even a temporary overload has some possibility to enlarge fault. The tutor shows a newly overloaded machine and its level, and gives warning.

Thirdly, it is desired not only to restore all blackout buses but also to

restore them quickly. The number of operations must be as few as possible. Unnecessary operations are not therefore allowed. Such operations indicate that knowledge on restoration is not thoroughly mastered. The tutor shows unnecessary operations.

Lastly, when several machines are operated, operations must be made from the source side to the load side. The tutor points out operations which do not obey this order, and shows the correct order.

#### 4.3 Procedure of evaluation

The above evaluations are performed along a flowchart of Fig. 16.

Firstly, each operation is checked to know if it is necessary or not. The following rules are applied here ;

1. If new blackout buses appear by an operation, then it is not necessary.
2. If no overloaded machines and no blackout load buses appear without an operation, then it is not necessary.

The result of evaluation according to these rules is written in the attribute NECESSITY.

Secondly, the results of the evaluation on the first three items are shown for each operation. Namely, the attributes BLACKOUT, OVERLOAD, and NECESSITY are referred. If BLACKOUT is not NIL, blackout buses are shown. If OVERLOAD is not NIL, overloaded machines are shown. If NECESSITY is NIL, it is shown that the operation is not necessary. If BLACKOUT and OVERLOAD are both NIL, and if NECESSITY is T, then no message is shown.

Lastly, the tutor evaluates the order of operations. The order is checked according to the following rule.

Fig. 16 Evaluation process.

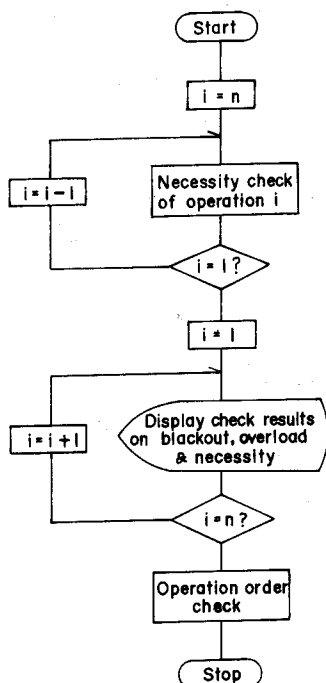

3. If an already operated machine exists on the load side of a machine operated by an operation, then the order is not correct.

If there are no mistakes, the tutor shows that the operations are correct, and ends the evaluation.

4. 4 Examples

<Example 1 >

Fig.17 shows a case where a fault occurred at transformer tr 03 in the Tennouji substation. Due to this fault, cb 520 and cb 230 were opened, and bus 03 lost power supply. The tutor evaluates 4 operations made by an operator as follows;

\*\*\*\*\* Evaluation \*\*\*\*\*

Operation

1. Off Tennouji-cb 310  
\*Tennouji-bus 02 lost power supply
2. On Tennouji-cb 220
3. On Tennouji-ls 123
4. On Tennouji-cb 320  
\*Operate in the order of  
Tennouji-ls 123  
Tennouji-cb 220

\*\*\*\*\*

The operator first opened cb 310. However, it stopped power supply to bus 02, so the tutor gave a warning about this operation. After that, the operator executed operations 2, . . . ,4, and restored all blackout buses without any overloads. The power failure at bus 02 lasted till operation 3, and that at bus 03 lasted till operation 4. However, operations 2, . . . ,4 are not the direct cause of the power failure, so an evaluation about power failure is not made on these operations. On the other hand, operations 2 and 3 have not been done in order

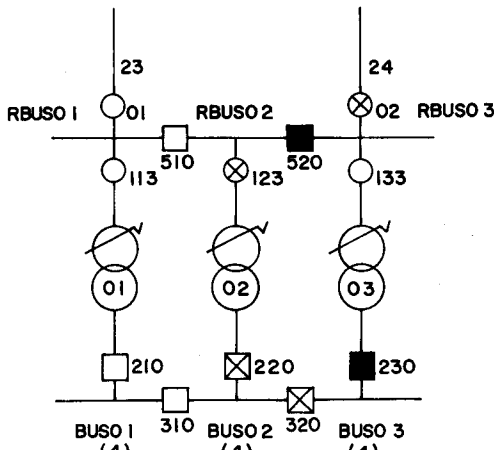

Fig.17 Example of evaluation—1.

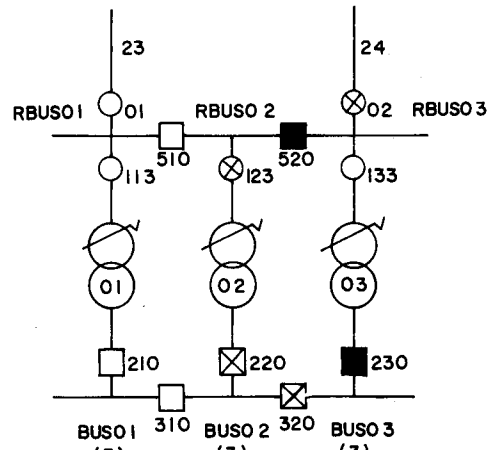

Fig.18 Example of evaluation—2.



from the source side, so the tutor shows the correct order.

<Example 2 >

Fig. 18 shows a case where tr 03 stopped due to a fault, too. The state of the power system is almost same as Fig. 17 except that the loads are all 3 Mva. The tutor evaluates 3 operations made by an operator as follows;

\*\*\*\*\* Evaluation \*\*\*\*\*

Operation

1. On Tennouji-ls 123  
\* This operation is unnecessary.
2. On Tennouji-cb 220  
\* This operation is unnecessary.
3. On Tennouji-cb 320

\*\*\*\*\*

By these operations, bus 03 is supplied from tr 01 and tr 02. The necessity of each operation is checked as follows. First, cb 320 closed by operation 3, is tentatively opened. Bus 03 loses power supply, so operation 3 is judged to be necessary.

Secondly, cb 220 is opened, then the current through tr 02 stops. All load buses are supplied through tr 01. The power through tr 01 is 9 Mva, so it is smaller than the capacity of tr 01. Tr 01 is therefore not overloaded, nor does a blackout bus appear. In conclusion, operation 2 is judged to be unnecessary.

The tutor similarly evaluates other operations. It judges operations 1 and 2 unnecessary. Only operation 3 is necessary to restore bus 03.

## 5. Conclusions

In this paper, a training simulator for secondary power system operations was developed to solve several problems in usual analog simulators. The main purpose of this paper was to replace instructors with expert systems.

Two expert systems, "solver" and "tutor", were developed for this purpose. The systems have their own knowledge bases consisting of operation and restoration rules, and are used in training operators as follows;

- 1) If an operator can not find operations to restore a fault, the solver generates an example of restoration operations for him. If requested, it also explains about each operation.
- 2) When an operator completes a fault restoration, then the tutor evaluates operations made by the operator.

The systems were applied to several fault cases in order to see if they work as

designed. By examining the obtained results, it was certified that the systems generally work well.

There are several cases, however, where the systems show somewhat unrealistic results. This is because the related operation rules have not yet been incorporated in the knowledge bases. The systems are not complete and are still being developed.

#### References

- 1) H. Suzuki, K. Ode, and T. Haba, "Development of automatic operation logic for normal condition.", *JIEE of Japan*, vol. 90, no. 9, pp. 1825-1834, 1970.
- 2) H. Suzuki and T. Haba, "Development of automatic operation logic for power system emergency condition.", *Trans. IEE of Japan*, vol. 93-B, no. 8, pp. 323-330, 1973.
- 3) R. Yokoyama, H. Kobayashi, and K. Kuze, "Multi-stage overload removal under operating constraints.", *Trans. IEE of Japan*, vol. 93-B, no. 10, pp. 485-492, 1973.
- 4) H. Suzuki, H. Kodama, Y. Kobayashi, and K. Ishizuka, "Power system switching logic for restorative operation on secondary system.", *Trans. IEE of Japan*, vol. 97-B, no. 3, pp. 111-118, 1977.
- 5) S. Abe and M. Goto, "Determination of steady-state switching sequence of power networks." *Trans. IEE of Japan*, vol. 97-B, no. 6, pp. 359-366, 1977.
- 6) A. Adibi, et al., "Power system restoration - A task force report.", *IEEE Trans.*, vol. PWRS-2, no. 2, pp. 271-277, 1987.
- 7) R. Kearsley, "Restoration in Sweden and experience gained from the blackout of 1983.", *IEEE Trans.*, vol. PWRS-2, no. 2, pp. 422-428, 1987.
- 8) J. Gutierrez, M. Staropolsky, and A. Garcia, "Policies for restoration of a power system.", *IEEE Trans.*, vol. PWRS-2, no. 2, pp. 436-442, 1987.
- 9) P. McCorduck, *MACHINES WHO THINK*, W. H. Freeman & Company, 1979.
- 10) K. Matsumoto and T. Sakaguchi, "Method to determine the restoration plan of power system by a knowledge based system" *Trans. IEE of Japan*, vol. 103-B, no. 3, pp. 175-182, 1983.
- 11) T. Sakaguchi and K. Matsumoto, "Development of a knowledge based system for power system restoration", *IEEE Trans.*, vol. PAS-102, no. 2, pp. 320-329, 1983.
- 12) T. Wake and T. Sakaguchi, "Method to determine the fault components of power system based on description of structure and function of relay system." *Trans. IEE of Japan*, vol. 104-B, no. 10, pp. 655-660, 1984.
- 13) K. Matsumoto and T. Sakaguchi, "Verification of operation sequence for substation switching equipments," *Trans. IEE of Japan*, vol. 104-B, no. 10, pp. 633-638, 1984.
- 14) K. Komai and T. Sakaguchi, "Analysis and evaluation of human knowledge for power system restoration by mathematical programming method." *Trans. IEE of Japan*, vol. 107-B, no. 6, pp. 269-275, 1987.
- 15) K. Okuda, et al., "An application of knowledge engineering for fault restoration operation in secondary power systems." *Trans. IEE of Japan*, vol. 107-B, no. 10, pp. 509-515, 1987.
- 16) *Eshell Manual V 01 L 03*, Fujitsu, 1986.
- 17) N. J. Nilsson, *Problem-solving methods in artificial intelligence*, McGRAW-HILL, 1971.