



TITLE:

Studies on corona in Transformer Oil by Measurement of Space charge

AUTHOR(S):

HAYASHI, Muneaki; YAMAMOTO, Osamu; ISA, Hiromu; MINO, Yoshiaki; UENOSONO, Chikasa; HIRABAYASHI, Shoji

CITATION:

HAYASHI, Muneaki ...[et al]. Studies on corona in Transformer Oil by Measurement of Space charge. Memoirs of the Faculty of Engineering, Kyoto University 1984, 46(3): 1-13

ISSUE DATE:

1984-10-30

URL:

<http://hdl.handle.net/2433/281272>

RIGHT:

Studies on corona in Transformer Oil by Measurement of Space charge

By

Muneaki HAYASHI, Osamu YAMAMOTO, Hiromu ISA, Yoshiaki MINO,
Chikasa UENOSONO and Shoji HIRABAYASHI

(Received December 27, 1983)

Abstract

Studies were carried out in needle-plane gaps with a comparatively long separation in transformer oil. Relations of needle voltage with space charge quantities due to coronas by lightning impulse and A. C. voltages were obtained. The charge quantities for AC voltage are larger than that for the impulse voltage. Back discharge phenomena take place, accompanied by sudden space charge reductions at the wave tail of the impulse voltage. The space charge quantity due to initial coronas at the wave front are reduced considerably by the phenomena.

1. Introduction

Studies on the electrical breakdown of transformer oil have already been carried out, and the mechanism of a corona discharge and breakdown have been gradually understood, being accompanied with developments of optical observation techniques by making use of an image converter camera, the Schlieren method and by combining these techniques. In order to cope with the tendency to raise voltages of electric power apparatuses and to compact their sizes accompanying the densification of electric power transmission, studies on breakdown phenomena of long gaps (several ten cm) in oil and on space charge effects upon the breakdowns have been increasing in importance. In this study, the light emission and the current due to corona in oil were observed as well as the space charge produced by the corona, when lightning impulse voltage or A.C. voltage was applied to the needle-plane gap (gap length : 50 mm~150mm) in oil. Through these observations and measurements, the length and the velocity of corona propagation, and the relationship between the amount of space charge and the applied voltage were investigated in order to study fundamental characteristics of the corona. As for the results, the following was deduced : there is the difference between corona space charges due to A.C. voltage and impulse voltage applications. As regards a lightning impulse application, the back discharge phenomena

occur around the needle electrode during the voltage attenuation, and then the quantity of corona space charge decreases by this back discharge.

2. Experimental apparatus and method

The schematic arrangement of the experimental apparatus in this study is shown in Fig. 1. The voltage wave form used here is $\pm 1,4/74(\mu s)$ in lightning impulse voltage or 60 Hz in A.C. voltage. The test electrodes system consists of a needle and a plane made of steel, where the gap length can be adjusted 0~200(mm). The system is placed in an oil-tank ($50 \times 50 \times 56 \text{ cm}^3$) made of acryl. The needle electrode has a 2 mm diameter, 30° tip angle, 0.1 mm curvature of the tip, and 44 mm length. The electrode is separated electrically from the supporting rod, as shown in the figure, in order to measure the needle current accompanying the corona growth. The plane electrode has a 450 mm diameter and a 10 mm curvature at the edge. The sort of oil was JIS #2, which had 2.2 in relative dielectric constant, $10^{13} \Omega \text{ cm}$ in specific electric resistance. New oil was poured into the tank which had been filled with N_2 gas in advance, in order to prevent humidity and oxygen from touching the oil. The oil was not changed during our experiment, since the oil volume was of 140 l, namely, sufficiently large, and the product of discharge in oil can be negligible.

The amount of the space charge Q_s , due to the corona discharge was measured from vorage V , across the capacitor C_s , which integrates the needle current i_s , associated with the corona discharge i.e. $Q_s = \int i_s dt = C_s \times V_s$. The time constant of this circuit was $400 \mu s$. The voltage V_s was converted into light signals through a Light Emission Diode (LED), and was transmitted to a photo-transistor through a light guide cable for re-conversion and oscilloscope observations.

An electrostatic probe was used to observe the process of the space charge formation with the corona growth, and its behavior after the growth. In Fig. 1, the sign Pr shows the probe of a metal sphere with a 10mm diameter. The probe was located at a height of 50 mm above the plane electrode and at 96.5 mm from

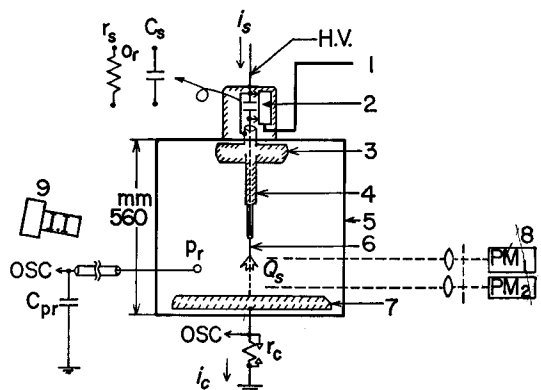

Fig. 1 Experimental apparatus.

- 1; light guide cable
- 2; LED
- 3; corona shield
- 4; supporter for needle electrode
- 5; oil tank
- 6; needle electrode
- 7; plane electrode
- 8; photomultiplier sets
- 9; still camera with image intensifier

the gap axis independently on the gap length. This location was far enough away from the corona to cause the space charge flow into the probe. Hence, a charge which related to the quantity of the corona space charge Q_s , is electrostatically generated on the probe. The probe was grounded through a capacitance C_{pr} . Accordingly, the quantity and behavior of the space charge can be investigated by this induced charge q_s , given by $q_s = C_{pr} \times V_{pr}$, where V_{pr} is the voltage across C_{pr} .

The quantity of q_s , as well as Q_s , was observed on the oscillograph superimposed on the component due to the displacement current caused by the applied voltage, namely the charge induced by a geometrical electric field. Then, in order to measure the space charge components accurately, the displacement components were cancelled using differential amplifiers of the oscilloscope.

The needle current i , was measured using the LED system. In this case, the capacitor C , was replaced by a shunt resistance r_s . The current flowing through the plane electrode was also measured by shunt r_e for reference.

In Fig. 1, the mark $PM_{1,2}$ abbreviates two sets of photomultipliers (Toshiba 7696) combined with lens and slit. Both photo-multipliers observed the light emissions from 1 mm width at different positions along the gap axis, so that the velocity of the corona development could be measured, where PM_1 was fixed to see the tip of the needle. A combination of a still camera and an imageintensifier was used to take pictures of the discharge shape, from which the corona length was measured. Together with these measuring apparatuses, 2 sets of 2-beam oscilloscopes (TEK 556 & 7844) were used to record the electric signals.

3. Corona and its space charge by impulse voltage

3.1 Properties of corona in oil.

The wave form of the currents, the light emission and the probe charge associated with the impulse corona are shown in Figs. 2 and 3. These oscillograms are obtained for positive and negative voltages respectively, where the gap length (δ) is 100 mm, and the peak value of the applied voltage is 70 kV.

As shown in Fig. 2, both the needle current i , and the plane current i_e show almost a similar shape with the light pulse at the needle tip. These waves have approximately a 6 μ s pulse width, and the probe charge q_s increases during the same period and keeps constant after that. From this fact, it is deduced that the space charge is generated just during the corona growth. As shown in Fig. 3, the probe charge for the negative corona behaves almost similar to that of the positive corona, where the currents contain the components of steep pulses.

Fig. 4 (a), (b) shows the oscillograms of the light pulses which present the development of the corona (by PM_1 , PM_2), for positive and negative coronas respectively.

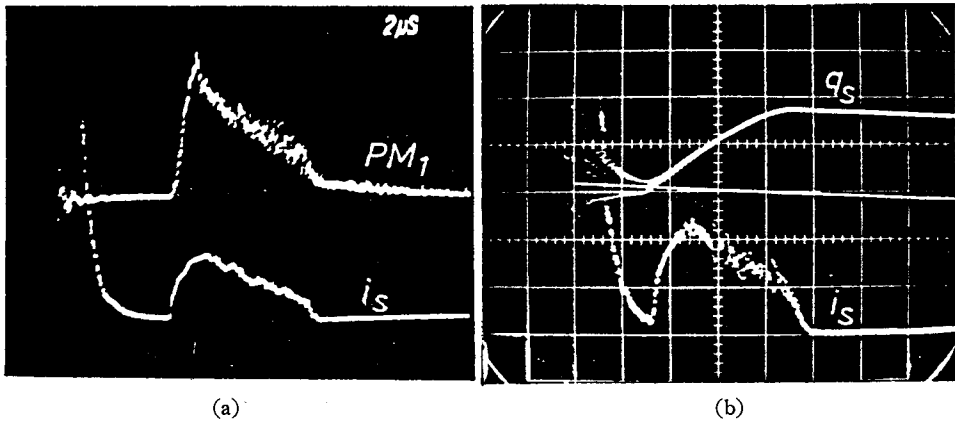

Fig. 2 Currents, probe charge and light pulses for positive impulse corona.
(i_n ; needle current, i_p ; plane current, PM_1 ; light pulse, $2 \mu\text{s}/\text{div}$.
 $\delta=100 \text{ mm}$, applied voltage $+70 \text{ kV}$.)

(a) i_n ; $5.1 \text{ mA}/\text{div}$.

(b) q_s ; $0.43 \text{ nC}/\text{div}$., i_n ; $2.0 \text{ mA}/\text{div}$.

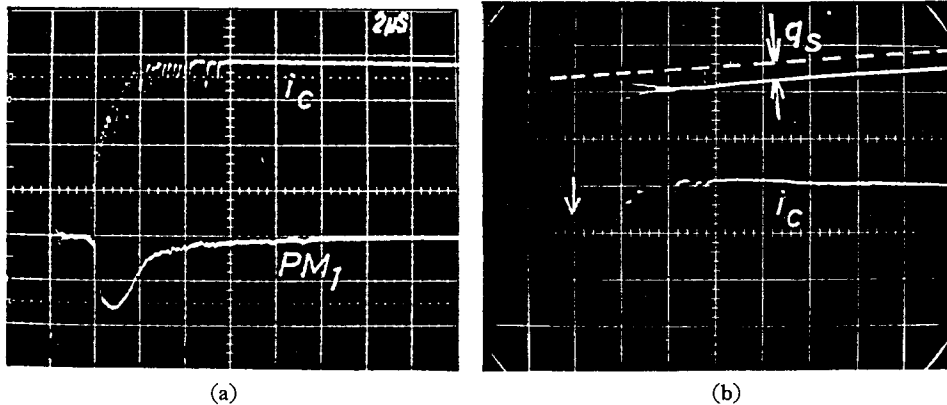

Fig. 3 Currents, probe charge and light pulses for negative impulse corona.
($2 \mu\text{s}/\text{div}$. $\delta=100 \text{ mm}$, applied voltage -70 kV .)

(a) i_n ; $2.5 \text{ mA}/\text{div}$.

(b) q_s ; $0.31 \text{ nC}/\text{div}$., i_n ; $2.0 \text{ mA}/\text{div}$.

Also shown are still photographs of the coronas. The propagation velocities of the coronas were found to vary with the peak value, and also with the polarity of the applied voltage. They also depend on the position from the needle tip, but they were of $1\sim 5(\times 10^5 \text{ cm}/\text{s})$ as the result of repeated experiments.

Fig. 5 gives the relationship between the corona length and the applied voltage V for both polarities, where the experiment was executed at $\delta=100 \text{ mm}$. From this figure, it is deduced that the development of the corona for positive polarity is larger by 2-4 times that that for negative polarity.

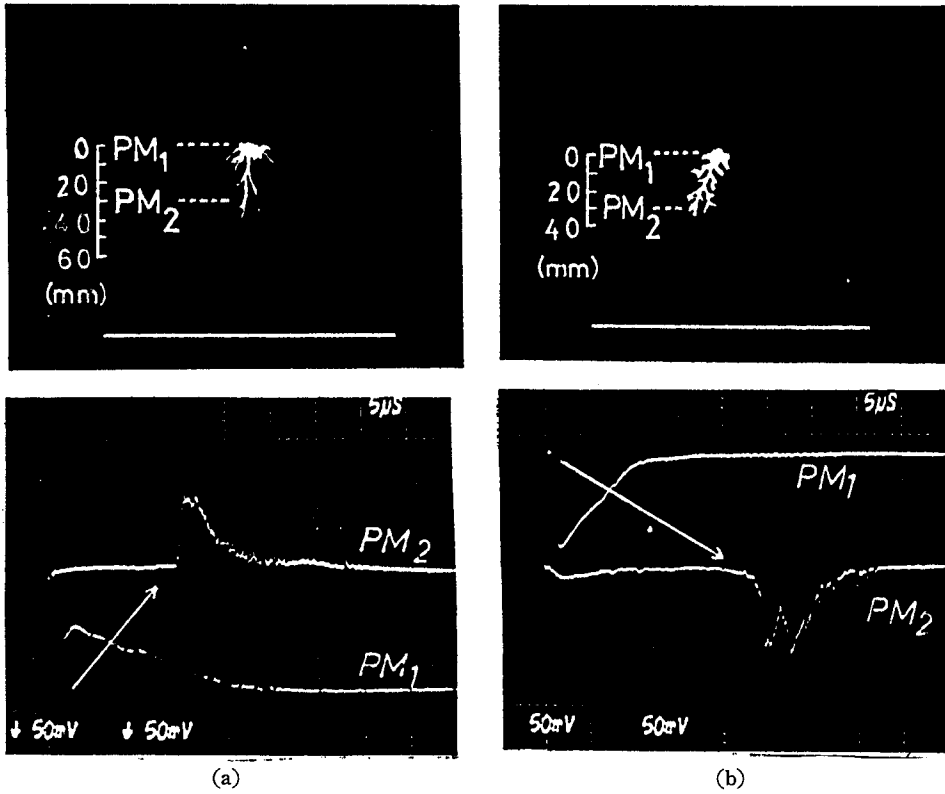

Fig. 4 Development of impulse corona. ($\delta=100$ mm, applied voltage +180 kV. PM₁; light emission at the needle tip, PM₂; light emission at 30 mm from the needle tip. 5 μ s/div.)
 (a) Positive corona
 (b) Negative corona

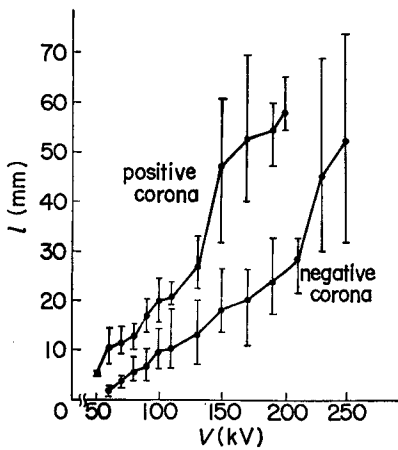

Fig. 5 Corona length l for impulse voltage application. ($\sigma=100$ mm)

3.2 Quantity of space charge.

The amount of the space charge Q_s generated in oil associated with the corona discharge was measured by integrating the needle current using the capacitance C_s , and the results are shown in Fig. 6 (a) and (b) for the applied voltage V . For both polarities of the voltage, the space charge Q_s increases steeply as the voltage increases. Such a characteristic can be presented approximately by the following exponential function:

$$Q_s = a \cdot \exp.(bV) \quad (1)$$

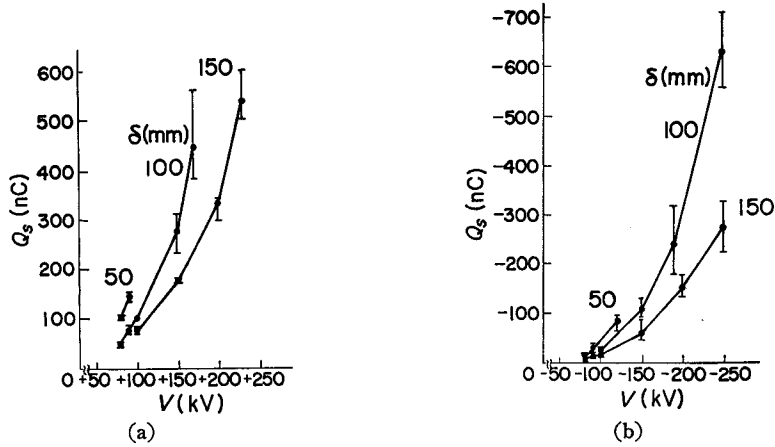

Fig. 6 Relations of corona space charge Q_s vs. impulse voltage V .
(a) Positive corona
(b) Negative corona

Table 1 Coefficients a and b in Eq. (1) .

(a) Positive corona

δ (mm)	$a (\times 10^{-9}, \text{nC})$	$b (\times 10^{-5}, 1/\text{V})$
50	13	2.7
100	7.5	2.5
150	19	1.45

(b) Negative corona

δ (mm)	$a (\times 10^{-9}, \text{nC})$	$b (\times 10^{-5}, 1/\text{V})$
50	1.1	3.6
100	0.36 ($V \leq 150 \text{kV}$)	3.86 ($V \leq 150 \text{kV}$)
	9.5 ($V > 150 \text{kV}$)	1.69 ($V > 150 \text{kV}$)
150	2.9	1.93

Table 2 Proportionality coefficient k of probe charge.

δ (mm)	k	positive corona	negative corona
50		3.3×10^{-2}	1.3×10^{-2}
100		2.9×10^{-2}	2.5×10^{-2}
150		2.8×10^{-2}	2.8×10^{-2}

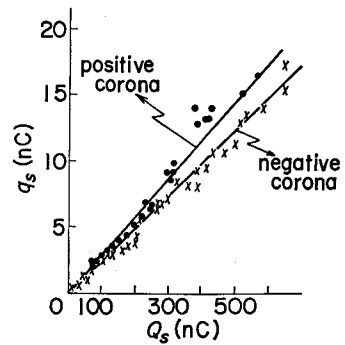

Fig. 7. Relations of probe charge q_s vs. Q_s .

where the constants a , b vary with the voltage polarity and with the gap length as shown in Table 1. From Fig. 6, Q_s becomes small as the gap length increases. In addition, Q_s by the positive corona is larger than that of the negative corona. For example, when the gap length is 100 mm, the positive corona has 2.5 times (at $V=150 \text{ kV}$) ~ 6.0 times (at $V=90 \text{ kV}$) the charge quantity

of the negative corona.

The probe charge q , induced on the probe due to the space charge Q_s , was measured simultaneously. The relations of q , with Q_s , for both polarities are presented in Fig. 7. With reference to Fig. 7, Q_s is proportional to Q_c , giving the next equation:

$$q_s = kQ_s \quad (2)$$

where, k is the proportionality coefficient.

The coefficient k in the above equation depends on the polarity of the applied voltage and on the gap length δ , as shown in Table. 2. From this table, it can be seen that the coefficient for the positive corona (k_+) exceeds that for negative corona (k_-). The difference ($k_+ - k_-$), however, decreases as the δ increases, and there exists no difference in the case of $\delta = 150$ mm. The reason may be attributed to a slight difference in the space charge distribution between the positive and negative coronas. The difference in the space charge distribution may cause less influence on $k_+ - k_-$ for a longer gap length, providing that the space charge is generated in the small corona volume near the tip of the needle electrode, and that k_{\pm} is given by a/d_{\pm} as the first approximation. (a : probe diameter, d_{\pm} : distance between the space charge and the probe.)

4. The corona and its space charge by A.C. voltage

The space charge measurement was executed by applying A.C. voltage. A typical aspect of the corona occurrence by A.C. voltage is shown in Fig. 8. This figure shows the oscillograms of the applied voltage V and the generated space charge Q_s around the needle electrode. As shown in the oscillogram of Q_s , both the positive and negative half cycles produce 1~3 pulses associated with the coronas. Since the charge quantity was measured by the terminal voltage of C_s , as mentioned earlier (See Fig. 1.), the peak value of every steep pulse corresponds to the amount of the space charge. The relation between the space charge quantity Q_s and A.C. voltage (in R.M.S.) is shown in Fig. 9. Q_s increases with the voltage, and has a large dispersion due to the value of the needle voltage at the instant of the corona occurrence.

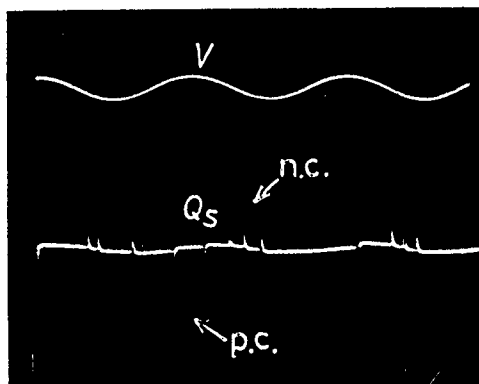

Fig. 8 Wave form of corona space charge for A.C. voltage. ($\delta = 100$ mm, Applied voltage 90 kV R.M.S., Q_s ; 133 nC/div., V; 440 kV/div., 5 ms/div.. P.C.; Positive corona, N.C.; negative corona.)

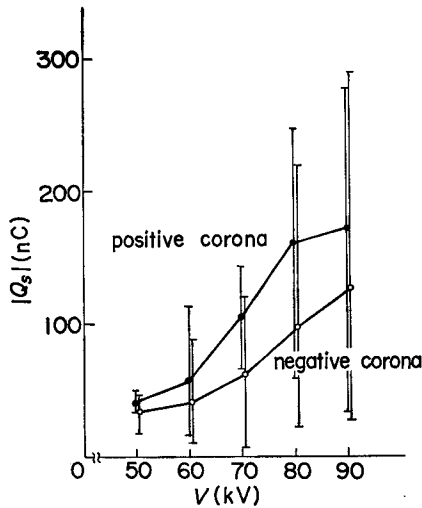

Fig. 9 Space charge Q_s by A.C. voltage. ($\delta=100$ mm. A.C. voltage in R.M.S.)

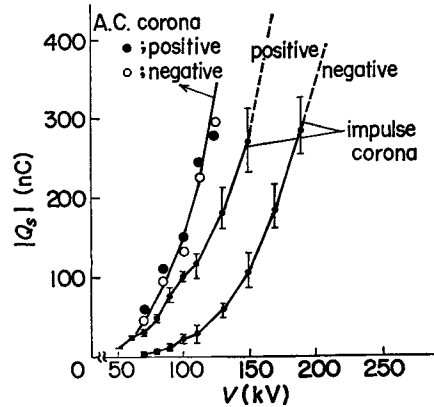

Fig. 10 Comparison of Q_s between A.C. corona and impulse corona. ($\delta=100$ mm. A.C. voltage in peak value.)

Comparing Q_s 's in positive and negative coronas mutually, the positive one is larger by 1.2 times (at $V=50$ kV) \sim 1.7 times (at $V=70$ kV) than the negative one. However, this ratio is 2.5 \sim 6.0 for the impulse voltages as described earlier. Then, it is found that the polarity effect on the corona space charge is rather small in the case of A.C. voltage application.

In Fig. 10, the space charge quantities for the impulse voltage and for the A.C. voltage are compared, taking an example by the gap length of $\delta=100$ mm. In this comparison, because of the dispersion in Q_s for the A.C. voltage, the maximum value of charge derived from Fig. 9 is adopted for A.C. peak voltage. According to Fig. 10, it is found that the charge for A.C. voltages is larger by 1.5 times \sim 2.2 times than that for positive impulse voltages, and about 7 times larger than that for the negative impulse voltages.

The difference in charge quantity between the A.C. corona and the impulse corona should be discussed, taking the space charge effect into account. That is, in case of the A.C. corona, the previous space charge accumulated in the oil gap during the latest half-cycle has a counter polarity against the needle voltage. Then, the electric field around the needle must be enhanced to cause a larger corona discharge. From this consideration and the fact that this effect acts distinctly upon the negative A.C. corona, it is deduced that more charge accumulation takes place during the positive half-cycle.

The wave form of corona currents and light pulses for A.C. voltage are shown

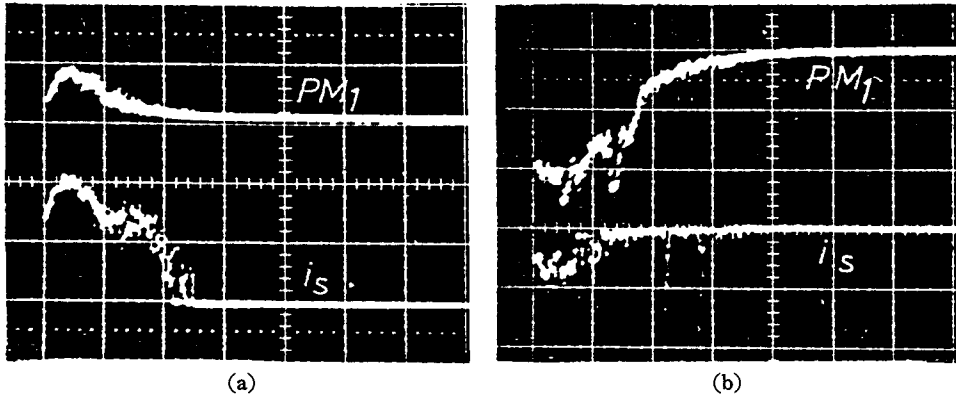

Fig. 11 Current and light pulses associated with A.C. corona. ($\delta=100$ mm. Applied voltage 68 kV in R. M. S., i_s ; 6.7 mA/div., 5 μ s/div.)
 (a) Positive corona
 (b) Negative corona

in Fig. 11(a), (b). Fig. 11(b) shows the negative A.C. corona which contains little steep pulse in contrast with the negative impulse corona, and is rather similar to that of the positive impulse corona. This change in the corona current may also be attributed to the space charge effect.

5. Back-discharge phenomena in transformer oil

Under a certain condition in surface discharges and discharges in air, so called back-discharge phenomena due to the space charge effect can be observed occasionally. In this study, the phenomena have been observed to occur in oil gaps as well, by applying impulse voltages. The process of this back discharge and the behavior of the space charge associated with the phenomena have been investigated.

5.1 Process of back-discharge phenomena.

As the first stage, observations were made on currents and light emissions, at a period more than some ten micro seconds after the initial corona which evolved near the crest of the impulse voltage. Fig. 12 gives the concept of this back-discharge phenomenon by the oscillograms of the applied voltage and the needle current.

Fig. 13 (a) and (b) shows the wave forms of the needle currents and the emitted light pulses due to the phenomenon in detail, for positive and negative voltags respectively. These detailed oscillogram were recorded

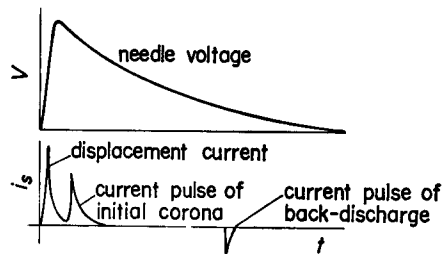

Fig 12 Time sequence of initial corona and back-discharge.

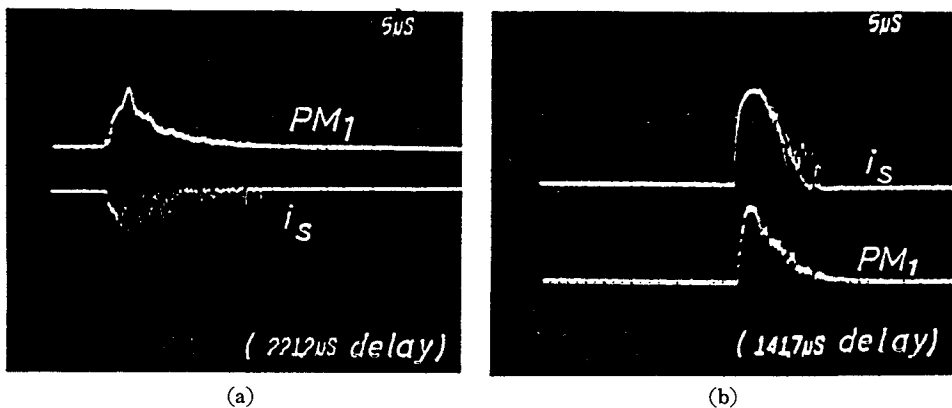

Fig. 13 Current and light pulses associated with back-discharge. ($\delta=100$ mm, $5 \mu s/\text{div.}$)
 (a) By positive impulse. (Applied voltage 150 kV. i_s ; 13.3 mA/div.)
 (b) By negative impulse. (Applied voltage of -210 kV. i_s ; 13.3 mA/div.)

by the use of a "trigger delay function" equipped in the oscilloscope. The back-discharge in Fig. 13 (a) occurs at about $220 \mu s$ after the voltage application of 150 kV in the peak value. It occurs while the voltage of the needle electrode at the instant of the back-discharge still remains about 10% of the peak value. Fig. 13 (b) shows the back discharge for a negative voltage of -210 kV. In this case, the phenomenon takes place at $160 \mu s$ after the voltage application, and the remnant needle voltage is about 20% of the peak value. In this experiment, the back discharge could always be observed for a wide range of the applied voltage.

Since the currents in Fig. 13 (a) and (b) have a reverse polarity against the applied voltage, the direction of charge flow due to the back discharge is considered to be of reverse of the initial corona at the first stage. The space charge produced by the initial corona (Q_i) makes a high and counter electric field, in contrast to the remnant geometrical field. Thus, the counter field causes the discharge from the space charge toward the needle electrode. The space charges consist of ions of both polarities, and the comparatively small mobility of ions in oil (about 4×10 cm/V.s) may be the reason for keeping the initial space charge in the gap.

The back-discharge spends, to some extent, the space charge produced by the initial corona, and causes a decrease in the probe signal. Fig. 14 (a) and (b) shows the probe signal for the positive and negative impulse voltages respectively. Each of them includes a geometrical component and the space charge component due to the initial corona. These probe signals show the sudden reduction on the wave form. For example, in Fig. 14 (a), the reductions take place at $110 \mu s$ and $320 \mu s$ after the voltage application. This means the occurrence of two backdischarges. The number of the back-discharges in every test was 1~2 for the positive and 1~3 for the negative

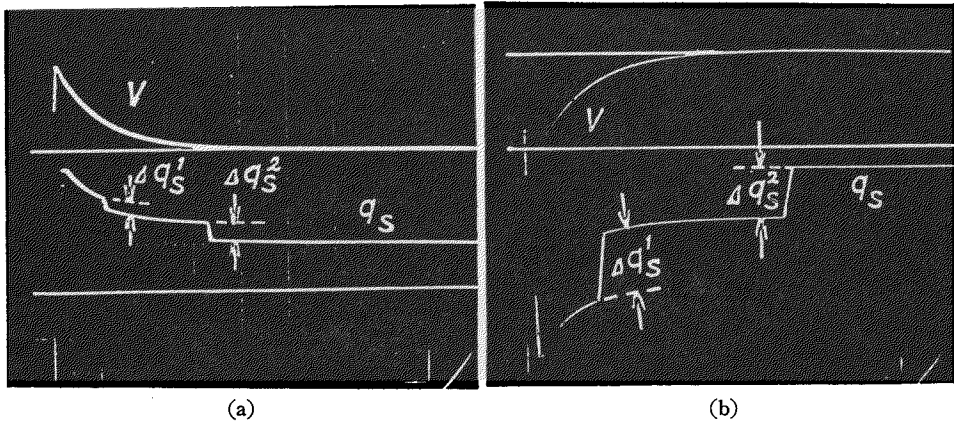

Fig. 14 Probe charge wave form associated with back-discharge. ($\delta=100$ mm, $100 \mu\text{s}/\text{div.}$)
 (a) By positive impulse voltage of 170 kV (q_s ; 4.3 nC/div., V ; 94 kV/div.)
 (b) By negative impulse voltage of -250 kV (q_s ; 4.3 nC/div., V ; 94 kV/div.)

polarity. In both cases, the number increased with the voltage, and the time of occurrence changed over the wide range of $50\sim 1000(\mu\text{s})$.

5.2 Space charge quantity due to back-discharge.

The amount of the charge consumed by the back-discharge in every test can be obtained by measuring the reduced quantity of the probe charge. Namely, the consumed charge in every back discharge is given by $\Delta q_i/k$, providing that Δq_i is the reduced probe charge associated with i -th back-discharge, and that k is the proportionality ratio given in Table 1. Therefore, the total charge ΔQ , consumed in one test is given by:

$$\Delta Q_s = 1/k \cdot \sum_i \Delta q_i^i \quad (3)$$

The relations of ΔQ_s and the applied impuse voltage are plotted as shown in Fig. 15. From this figure, the difference in ΔQ_s due to the polarity of the applied voltage can not be observed as is in the case of initial corona (See Fig. 6.)

The relations between the charge Q_s due to initial corona and ΔQ_s due to the back discharge are shown in Fig. 16 (a) and (b), for the positive and negative impulse voltages respectively. With reference to these figures, it is found that ΔQ_s has a linear

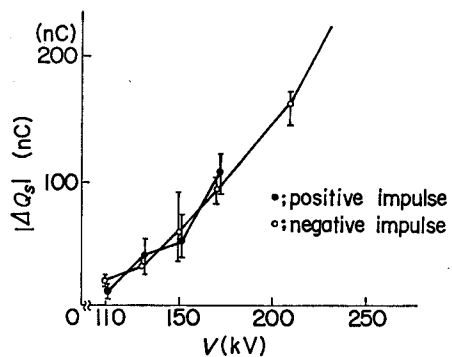
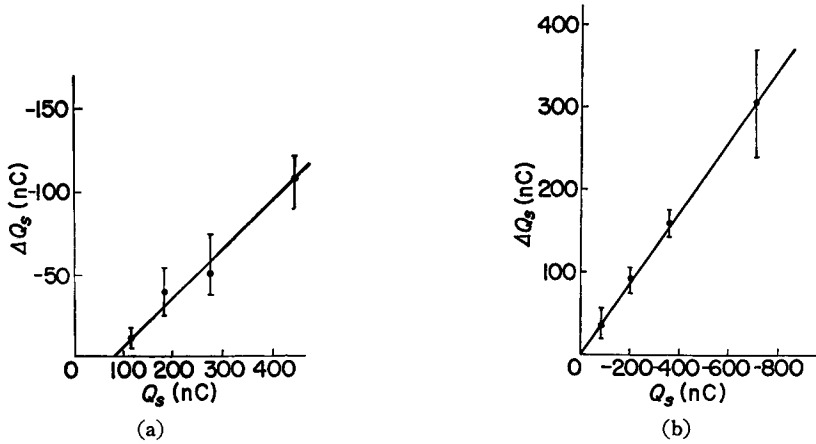

Fig. 15 Relations of charge ΔQ_s due to back discharge vs. impulse voltage. ($\delta=100$ mm)

Fig. 16 Relations of ΔQ_s vs Q_s ($\delta=100$ mm)

- (a) Positive impulse voltage
(b) Negative impulse voltage

relationship with Q_s , presented by next equations.

For the positive impulse voltage, we have

$$\Delta Q_s = 0.29 Q_s - 22 \text{ nC.} \quad (4)$$

and for negative impulse voltage;

$$\Delta Q_s = 0.43 Q_s. \quad (5)$$

Thus, it is concluded that the initial space charge reduces to 75%~85% for the positive corona and to 57% for the negative corona due to the back-discharges.

6. Conclusion

In this study, the space charge quantity due to the corona of the needle-plane gaps in transformer oil has been measured for lightning impulse voltage and A.C. voltage. The results have been obtained as follows:

- 1) Concerning the lightning impulse voltage application, the charge quantity due to the corona for positive voltage is larger by 2.5~6.0 times than that for negative voltage. However, the charge quantities for the positive and negative cycles of A.C. voltage are nearly equal.
- 2) The space charge quantity due to the corona for A.C. voltage is larger than that for impulse voltage. The charge quantity for the A.C. positive cycle is larger by 1.5 times ~2.2 times than that for the positive impulse voltage. The charge quantity for the negative cycle is larger by about 7 times than that for the negative impulse voltage.
- 3) The back discharge phenomena take place around the needle electrode for

impulse voltage applications. The space charge due to corona at the initial stage decreases to 75%~85% by the back-discharge for a positive polarity, and to 57% for a negative polarity.

Acknowledement

The authors are thankful for the contributions to this experiment given by Mr. Shigeyoshi Ishitoku, student of Kyoto Univerty, and also for the useful discussions and support given by Mr. Tsutom Tani, Mitsubishi Electric Co..

Reference

- 1) M. Ishikawa et. al., "Time Behavior of Pre-Breakdown Density Change in Transformer Oil" I. E. E. of Japan, Vol. 101-A, No. 5, 1981
- 2) M. Ishikawa et. al., "Pre-Breakdown Density Change and Prebreakdown Current in Transformer Oil" *ibid.*, Vol. 102-a, No. 11, Nov., 1982
- 3) C. Uenosono, O. Yamamoto et. al., "Measurement of Space Charge in Air Gap Using Electrostatic Probe" *ibid.*, Vol. 102-A, No. 4, 1982