



TITLE:

Statistical Analysis of Pressure Fluctuations in Vertical Two-Phase Flow

AUTHOR(S):

SAKAMOTO, Ryuichi; KIKUCHI, Yoshihiro;
NISHIHARA, Hideaki; MICHİYOSHI, Itaru

CITATION:

SAKAMOTO, Ryuichi ...[et al]. Statistical Analysis of Pressure Fluctuations in Vertical Two-Phase Flow. *Memoirs of the Faculty of Engineering, Kyoto University* 1981, 43(2): 173-183

ISSUE DATE:

1981-06-25

URL:

<http://hdl.handle.net/2433/281173>

RIGHT:

Statistical Analysis of Pressure Fluctuations in Vertical Two-Phase Flow

By

Ryuichi SAKAMOTO*, Yoshihiro KIKUCHI*, Hideaki NISHIHARA**
and Itaru MICHYOSHI*

(Received December 26, 1980)

Abstract

An experimental study was conducted on pressure fluctuations in vertical two-phase air-water flow. Statistical analysis of measured fluctuations was used to identify flow regimes in two-phase flow. Random ripple fluctuations were observed in bubbly flow. In slug and churn flows, however, violent oscillations were caused by the periodic passage of liquid and gas slugs. These oscillations were weakened with a further increase of gas flowrate, and small ripple fluctuations again appeared in annular flow.

1. Introduction

In the past 25 years an increasing number of research papers have appeared on the subject of two-phase gas-liquid flow and heat transfer. Most of the initial works were performed for understanding the physical phenomena under steady or quasi-steady conditions, by measuring time-averaged quantities of pressure drop, void fraction, heat transfer coefficient etc. Little attention was paid to the inherent statistical and fluctuating characteristics of two-phase flow systems since they would cause additional complexities. Neglect of these characteristics, however, may result in incomplete or misleading conclusions.

Several studies have recently been conducted on the statistical characteristics of pressure fluctuations in two-phase flows. Ishigai et al.¹⁾ related pressure fluctuations directly to individual components flowing in a vertical air-water flow system. Hubbard and Dukler²⁾ studied wall pressure fluctuations below 10 Hz in horizontal air-water flow. They distinguished essentially three types of power spectral density distribution obtained from pressure fluctuation measurements. Adachi and Torikai³⁾ showed that a violent pulsating pressure was

* Department of Nuclear Engineering

** Research Reactor Institute

observed for a fixed slug length in a vertical two-phase flow system. Nishikawa et al.⁴⁾ studied static pressure fluctuations in vertical air-water flow and found two components of pressure fluctuation, which were overall and local. Akagawa et al.⁵⁾ studied fluctuations of pressure difference below 50 Hz in vertical air-water flow.

Kinoshita and Murasaki⁶⁾ reported measurements of fluctuating dynamic pressure at a Pitot probe in air-water flow. By carrying out a correlation analysis of the signals below 10 Hz, it was possible to identify definite periodicity in the pressure fluctuation process.

Although the characteristics of pressure fluctuations depend on many parameters, i.e. gas and liquid flowrates, flow regimes, instrumental geometry etc., it has been expected that pressure fluctuations may serve as an indicator for observing the types of flow regime. It has also been expected that the measured signals may be used for controlling the operation of two-phase flow systems. Most of the above-mentioned studies, however, were carried out under comparatively low flow velocity conditions. Higher velocity conditions are established in practical systems such as conventional and nuclear power stations.

In order to obtain further detailed knowledge of this subject, the present experiments have been carried out through pressure fluctuations in vertical air-water flow in a round tube under high velocity conditions, up to 4 ms^{-1} of superficial liquid velocity and 36 ms^{-1} of superficial gas velocity. The measured signals will be analyzed statistically to obtain the intensity, the probability density function, the power spectral density distribution and the cross correlation of the pressure fluctuations. These statistical quantities will be used to characterize the types of two-phase flow regimes.

2. Experimental Apparatus and Procedure

2.1 Apparatus

A schematic diagram of the experimental apparatus is shown in Fig. 1. It contained a water loop and an air injection system. The main circulation and the by-pass lines were made of stainless steel piping of 28 mm nominal diameter. Water delivered by a pump was regulated by valves and mixed with air at the inlet of the test section. A two-phase mixture flowed through the test section and entered a separation tank, where the air was released to the atmosphere, after which the water returned to the pump for recirculation. In the air injection system, air pumped by a compressor was stored in an accumulator to reduce its flow and pressure fluctuations. The test section consisted of a vertical acrylic tube of 10.2 mm inner diameter and 2.7 m length.

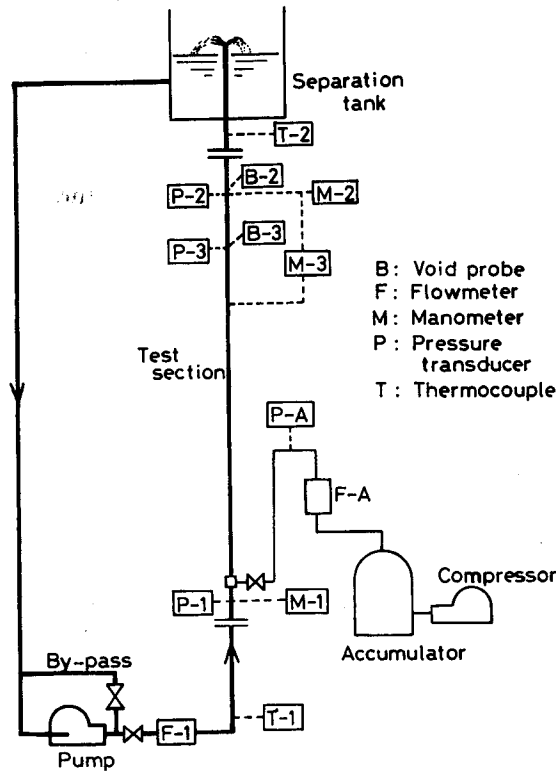

Fig. 1. Schematic diagram of experimental apparatus.

Pressure fluctuations in two-phase flow were measured by strain-gauge type pressure transducers P-1, P-2 and P-3, which had a flat response performance in the frequency range of 0~1 kHz. The distance between the pressure transducers P-2 and P-3, which were installed in the downstream region of the test section, was 380 mm. Manometers M-1 and M-2 were provided for time-averaged static pressure measurements at the inlet and the outlet, respectively. Pressure drop measurements in two-phase flow were also achieved by manometer M-3. Air pressure fluctuation was measured by a pressure transducer P-A.

Flowrates of water and air were measured by a turbine-type flowmeter F-1 and a float-type flowmeter F-A, respectively. Inlet and outlet temperatures were measured by thermocouples T-1 and T-2, respectively. Two resistivity probes, B-2 and B-3, were provided for measuring local liquid or gas slug velocity at the same points as the pressure transducers P-2 and P-3, respectively.

Each run was performed in the following manner. Water flowrates of the test section and the by-pass were first set at fixed values. Air was injected and then

regulated by throttling the valve opening. Sufficient time was needed for the two-phase flow development to reach a steady state. Upon reaching a steady state, the signals of flow and pressures were simultaneously recorded by a data acquisition and processing system, the detailed description of which will be given in the following section.

The experiments were conducted at room temperature under the following conditions:

Superficial liquid velocity u_{l0} :	0.5~ 4.0 ms ⁻¹ ,
Superficial gas velocity u_{g0} :	0.0~36.0 ms ⁻¹ ,
Quality x :	0.0~0.1.

These conditions covered two-phase flow regimes of bubbly, slug, churn and annular flows.

2.2 Instrumentation System

Figure 2 shows the instrumentation and data processing system for the pressure fluctuation signals. The system was devised for detecting, conditioning, recording, and analyzing the pressure signals associated with two-phase flow.

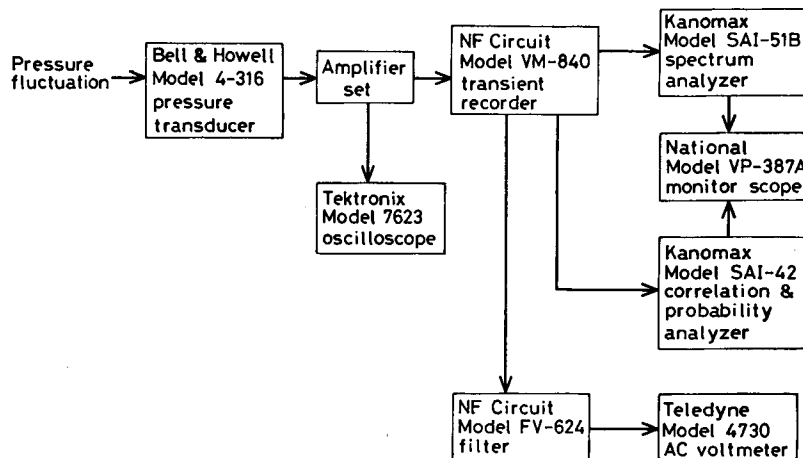

Fig. 2. Instrumentation and data processing system for pressure fluctuation signals.

Strain-gauge type pressure transducers were installed along the test section, as described in Sec. 2.1. The transducers (Bell and Howell Model 4-316) had a flat response up to 1 kHz. The signals from these transducers were amplified and then recorded on an NF Circuit Model VM-840 transient recorder. Fluctuations up to 200 kHz could be recorded. For monitoring, a Tektronix Model 7623 oscilloscope was used.

A Kanomax Model SAI-51B real-time spectrum analyzer was used for the spectral measurements. This unit had a frequency range from 0 to 50 kHz. The spectral display appeared on the screen of a National Model VP-387A monitor scope. The frequency of the applied signal was scaled on the horizontal axis, and the intensity of the signal was displayed on the vertical axis.

A Kanomax Model SAI-42 correlation and probability analyzer was used for obtaining the cross correlation and the probability density functions of the fluctuation signals. This unit had a frequency range from 0 to 250 kHz.

A Teledyne Model 4730 AC voltmeter was used for measuring the fluctuation intensity, regulated by an NF Circuit Model FV-624 filter. The AC voltmeter had a flat response up to 50 Hz.

3. Result and Discussion

3.1 Wave Form of Pressure Signal

Figure 3 shows typical signals of two-phase flow pressure fluctuations (called "wave forms"), measured by the pressure transducer P-2, which was set near the outlet of the test section. Superficial liquid velocity u_{l0} was maintained at 0.5 ms^{-1} , and superficial gas velocity u_{g0} was varied up to 36.0 ms^{-1} , corresponding to the change of flow regimes as indicated in the figure. Wave forms are seen to be characterized distinctly by their flow regimes. Gas injection caused small ripple-like fluctuations in bubbly flow, and the wave form could be easily distinguished from that of a single-phase liquid flow. In slug flow more violent oscillations were observed. Fluctuation was amplified with a higher velocity of gas. After attaining a maximum in churn flow it then decreased, resulting in a small ripple pattern in annular flow.

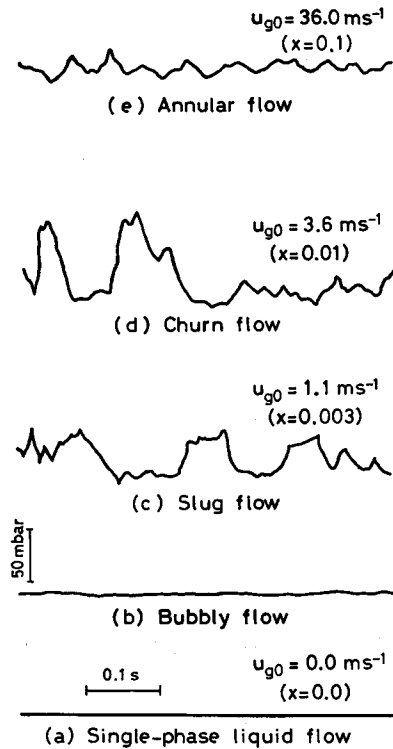

Fig. 3. Effect of flow regime on wave form of pressure fluctuation ($u_{l0}=0.5 \text{ ms}^{-1}$).

3.2 Intensity of Pressure Fluctuation

Figure 4 shows the effect of quality x on the pressure fluctuation intensity I .

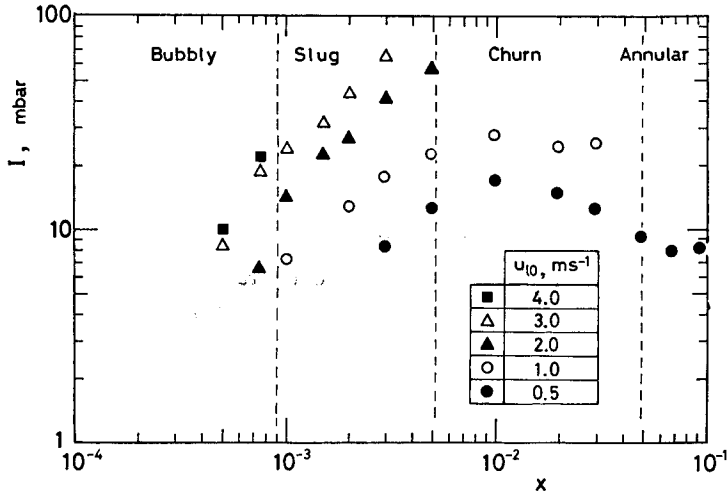

Fig. 4. Effect of quality on intensity of pressure fluctuation.

In this figure the intensity is expressed in RMS* value. The intensity increased with increasing quality, and after attaining a maximum in churn flow, it then decreased. This tendency was consistent with the experimental results of Nishikawa et al.⁴⁾ At a given quality the intensity increased with increasing liquid velocity (u_{10}). Pressure fluctuations (10~100 mbar) associated with two-phase flow were much greater than the approximately 1 mbar in single-phase liquid flow.

3.3 Probability Density Function of Pressure Fluctuation

Figure 5 shows the effect of flow regime on the probability density function (PDF) of pressure fluctuations. A mark “△” indicates a time-averaged value of pressure. In single-phase liquid flow (Fig. 5(a)), the PDF had a sharp peak at the average point, corresponding to no detectable pressure fluctuations. This peak became more gentle in bubbly flow because of small random fluctuations, as shown in Fig. 5(b). In slug flow (Fig. 5(c)), however, two peaks were observed on both sides which were different from the average point. The reason is that violent oscillations were caused by periodic passages of gas and liquid slugs. The right-hand (high-pressure) peak disappeared in churn flow and only a large peak was observed in the left-hand (low-pressure) side, as shown in Fig. 5(d). In annular flow (Fig. 5(e)), a broad peak was again observed at the average point, similar to the one in bubbly flow. This may be attributed to small random ripples in the pressure fluctuation signals.

* RMS=root mean square

3.4 Frequency Spectrum of Pressure Fluctuation

Figure 6 shows typical frequency spectra of pressure fluctuations. The horizontal axis is frequency f , and the vertical axis is intensity given as the power spectral density (PSD). It can be seen that gas injection caused a considerable increase in intensity at all frequencies. Low-frequency components (<5 Hz) of the spectra were dominant in single-phase liquid flow. In two-phase flows, however, the spectra had a nearly flat distribution up to 40 Hz. In slug and churn flows a broad peak, which was observed at approximately 5 Hz, moved into the lower frequency with increasing gas velocity. In annular flow, however, there were no peaks in the spectra, and a flat curve extended up to 40 Hz.

3.5 Cross Correlation of Pressure Fluctuations

Figure 7 shows the effect of flow regime on cross correlation functions of pressure fluctuations. These were measured by two pressure transducers P-2 and P-3, which were 380 mm distant from each other. In single-phase liquid flow (Fig. 7(a)), a large peak was observed at 0 s. This means that the pressure fluctuations were not transported by flow, but were possibly caused by simultaneous systematic oscillations of fluid. In bubbly flow, however, there was no correlation, as shown in Fig. 7(b). This may be attributed to the fact that the pressure fluctuations caused by small bubbles were so small and random that they were easily damped and then disappeared immediately near their sources.

A distinct peak was observed at approximately 0.03 s in slug flow, as shown in Fig. 7(c). This time was in good agreement with the time interval needed

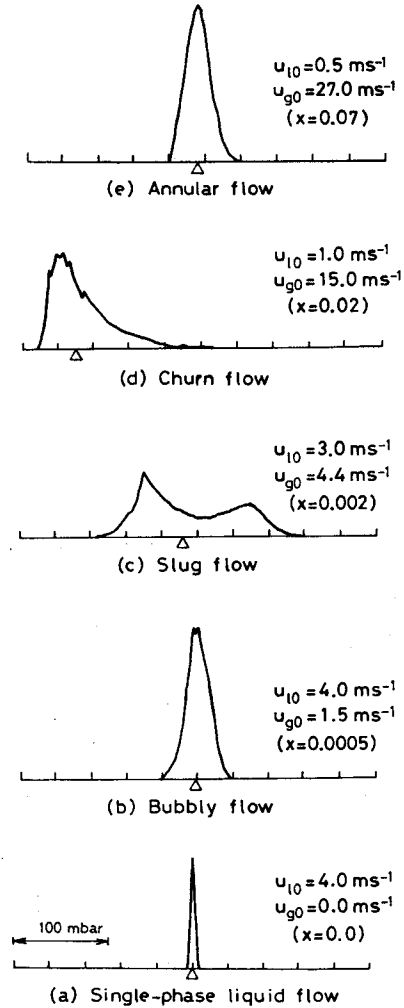

Fig. 5. Effect of flow regime on probability density function of pressure fluctuation.

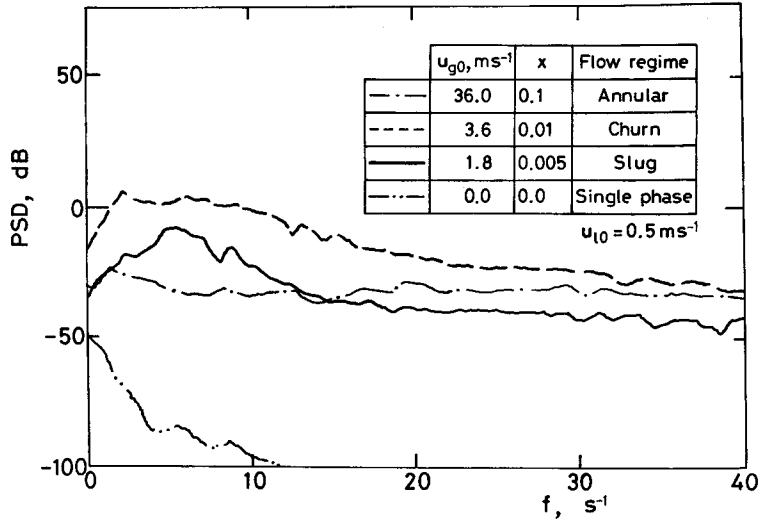

Fig. 6. Frequency spectra of pressure fluctuation.

for a gas slug to pass through the distance (380 mm) between two measuring points, which was evaluated from void probe signals.⁷⁾

In annular flow (Fig. 7(d)), two peaks were observed: a large one at 0 s and a small one at approximately 0.05 s. The former was caused by simultaneous systematic oscillations of fluid while the latter by intermittent passages of liquid droplets and/or disturbance waves.

From the above-mentioned observations it is possible to evaluate the velocity of a gas slug by the cross correlation of pressure fluctuations, i.e. the distance between two measuring points being divided by the time interval when a peak was observed in the cross correlation function. Figure 8 shows the slug velocities which were obtained by the cross correlation method (pressure transducer) as well as the direct method (void probe). The horizontal axis is superficial two-phase velocity $u_{l0} + u_{g0}$ and the vertical axis is gas slug velocity u_g . It can be seen that u_g increased with higher superficial two-phase velocity.

The solid line drawn in the figure indicates the well-known empirical correlation of slug velocity proposed by Nicklin et al.⁸⁾

$$u_g = 1.2(u_{l0} + u_{g0}) + 0.35(gD)^{1/2}, \tag{1}$$

where g and D are acceleration due to gravity and tube diameter, respectively. The present data obtained from void signals were in good agreement with the correlation of Nicklin et al. The data predicted from pressure signals, however, were scattered a little, and several plots fell above the equation of Nicklin et al. This discrepancy could be attributed to the fact that the no-delay-time components

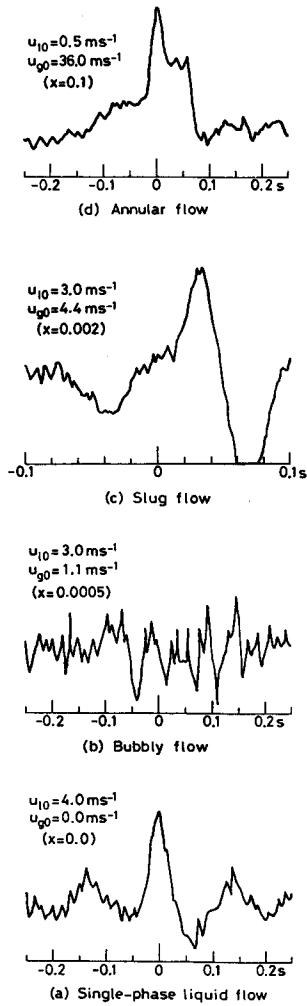

Fig. 7. Effect of flow regime on cross correlation of pressure fluctuations.

of cross correlation function increased due to pressure fluctuations caused by something other than the passage of slugs, but further detailed analyses will be needed.

4. Conclusion

An experimental study was conducted on the effect of flow regime on pressure fluctuations accompanied with a two-phase air-water mixture flowing in a vertical tube. Liquid flowrate was maintained at a fixed value. As gas flowrate was increased, the two-phase flow regime changed in sequence of bubbly, slug, churn

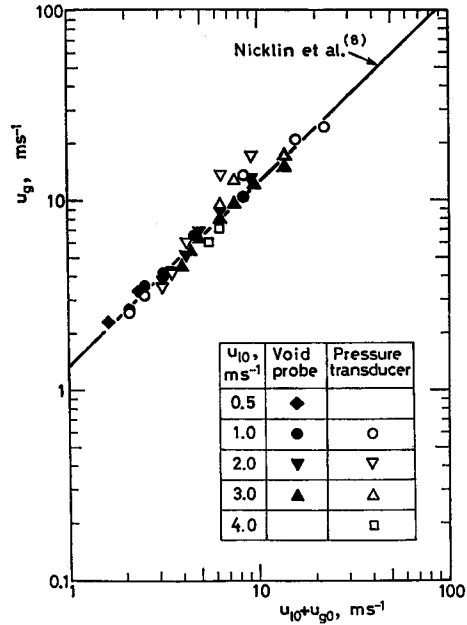

Fig. 8. Effect of superficial two-phase velocity on gas slug velocity.

and annular flows. For each flow regime the signals from pressure transducers were recorded and analyzed.

The following conclusions were drawn:

- (1) The pressure fluctuations in two-phase flow are much larger than those in single-phase liquid flow, and the wave forms of their signals can be characterized by the types of flow regime.
- (2) The fluctuation intensity first increases with increasing quality, and after attaining a maximum in the churn flow regime, it then decreases.
- (3) The frequency spectra of fluctuations observed in two-phase flow differ from those in single-liquid flow. In the slug and churn flow regimes a broad peak appears at approximately 5 Hz because of the periodic oscillations of pressure fluctuations. In the annular flow regime, however, the spectra have a flat curve up to 40 Hz.
- (4) The probability density function of fluctuations has two peculiar peaks in the slug flow regime. This is attributed to the fact that both liquid and gas slugs pass periodically.
- (5) From the cross correlation of fluctuations measured at two different points, the fluctuations are caused by the simultaneous systematic oscillation of fluid in the single-phase liquid and the two-phase annular flow regimes. In the slug and the churn flow regimes, however, the oscillative fluctuations are transported by flow. In the bubbly flow regime there is no correlation, consequently the fluctuations can not be transported since they disappear immediately near their sources.
- (6) Most of the slug velocities predicted from the cross correlation of pressure fluctuations agree fairly well with the correlation of Nicklin et al. But several plots fall above the correlation curve.

Further detailed analyses of these data, especially pulsating pressures observed in the slug and the churn flow regimes, will be needed for evaluating theoretical models of pressure fluctuation.

Nomenclature

- D : Tube diameter
 f : Frequency
 g : Acceleration due to gravity
 I : Intensity of pressure fluctuation
 u_g : Gas slug velocity
 u_{g0} : Superficial gas velocity

- u_{10} : Superficial liquid velocity
 x : Quality

References

- 1) S. Ishigai et al.: Measurement of Component Flows in a Vertical Two-Phase Flow by Making Use of the Pressure Fluctuations, *Trans. Japan Soc. Mech. Engrs.*, **30** [219], 1323~1329 (1964).
- 2) M.G. Hubbard & A.E. Dukler: The Characterization of Flow Regimes for Horizontal Two-Phase Flow. 1. Statistical Analysis of Wall Pressure Fluctuations, *Proc. Heat Transfer Fluid Mech. Conf.*, 101~121 (1966).
- 3) K. Adachi & K. Torikai: Pressure Oscillations in Slug Flow, Preprint of 720th Meeting of Japan Soc. Mech. Engrs, p. 5 (1964).
- 4) K. Nishikawa et al.: On the Pulsation Phenomena in Gas-Liquid Two-Phase Flow, *Trans. Japan Soc. Mech. Engrs.*, **35** [271], 582~596 (1969).
- 5) K. Akagawa et al.: Studies on the Fluctuation of Pressure Drop in Two-Phase Slug Flow, *Trans. Japan Soc. Mech. Engrs.*, **36** [289], 1520~1542 (1970).
- 6) T. Kinoshita & S. Murasaki: On a Stochastic Approach to the Pulsating Phenomena in Two-Phase Flow, *Trans. Japan Soc. Mech. Engrs.*, **34** [267], 2003~2011 (1968).
- 7) R. Sakamoto: Pressure Fluctuation in Vertical Two-Phase Flow, MS thesis, Kyoto University, 1980.
- 8) D.J. Nicklin et al.: *Trans. Inst. Chem. Engrs.*, **40**, 61 (1962).