



TITLE:

# The Leader Development and its Mechanism in Air under Impulse Voltage

AUTHOR(S):

ISA, Hiromu; HAYASHI, Muneaki

---

CITATION:

ISA, Hiromu ...[et al]. The Leader Development and its Mechanism in Air under Impulse Voltage. Memoirs of the Faculty of Engineering, Kyoto University 1977, 38(4): 218-239

ISSUE DATE:

1977-02-21

URL:

<http://hdl.handle.net/2433/281012>

RIGHT:

# The Leader Development and its Mechanism in Air under Impulse Voltage

By

Hiromu ISA\* and Muneaki HAYASHI\*

(Received June 30, 1976)

## Abstract

In this paper, the breakdown phenomena in air for both short and long gaps of 3~20 cm length were observed by means of the voltage, current, light pulse measurement and the still photograph observation (accompanied with chopped voltage). Also, the role played by primary and secondary streamers for leader inception and its development are studied. As a result, several delayed streamers which were named here, and which were made of sets of primary and secondary streamers, were observed; and only when the current pulse of a delayed streamer continues without interruption, the leader occurred.

## 1. Introduction

It is known that the electrical breakdown phenomenon under impulse voltage includes several stages such as a primary streamer, a secondary streamer and an arc for a short gap<sup>1-3)</sup> and a streamer, a leader and an arc for a long gap.<sup>4-6)</sup> Since the breakdown phenomena for short gaps were apparently different from those for long gaps, these studies have been carried out separately for the phenomena in the two ranges of the gap length. In this paper, however, the breakdown phenomena in air are studied for both short and long gaps, where the gap length is 3~20 cm. The phenomena are observed by means of the voltage, current, light pulse measurement and the still photograph observation (most of them, accompanied with chopped voltage), in order to understand the role played by primary and secondary streamers (PS & SS) for the leader inception and its development.

## 2. Experimental Apparatus

The experimental arrangement is shown in Fig. 1.  $C_0$ ,  $R_0$  and  $S$  constitutes the main part of the impulse generator (4 stages, series-parallel-charging type, nominal output voltage 280 kV). The output voltage has the standard wave

---

\* Department of Electrical Engineering

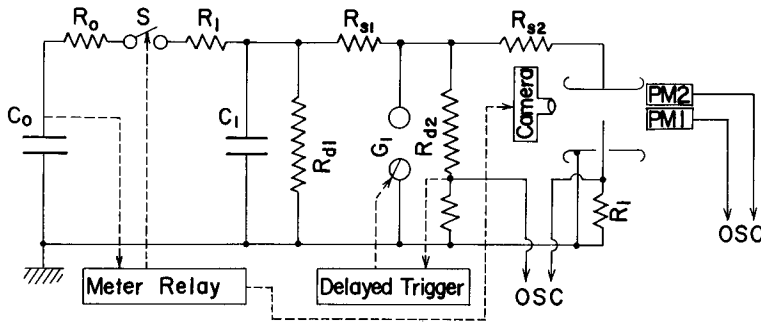

$C_0 = 0.05 \mu\text{F}$ ,  $C_1 = 1100 \text{pF}$ ,  $R_0 = 80 \Omega$ ,  $R_1 = 250 \Omega$ ,  
 $R_{s1} = 250 \Omega$ ,  $R_{s2} = 45 \Omega \sim 40 \text{k}\Omega$ ,  $R_{d1} = 1 \text{k}\Omega$ ,  
 $R_{d2} = 10 \text{k}\Omega$ ,  $R_l = 75 \Omega$   
 $G_1$ : Gap for Voltage Chopping

Fig. 1. Arrangement of experimental apparatus.

form  $\pm(1.5 \times 40) \mu\text{s}$ , and the wave front may be varied by adjusting  $R_1$  and  $C_1$ . The electrodes for the test are made of brass, and forms a hemispherical rod-to-plane gap. The tip radii ( $\rho$ ) of the rod electrodes are  $0.5 \sim 7.5 \text{ mm}$ , and the gap length ( $\delta$ ) are varied in the range of  $3 \sim 20 \text{ cm}$ . In this experiment,  $\rho = 2 \text{ mm}$ ,  $\delta = 5, 15 \text{ cm}$  were mainly used. The plane electrode is a disc of  $25 \text{ cm}$  diameter and has a round edge of  $15 \text{ mm}$  radius. For reducing the effect of noise and charging current, a guard electrode which had a similar structure to the plane electrode and was earthed, was arranged near the rod electrode. The rod was earthed and the high voltage was applied to the plane electrode. The observed items were the voltage, current, and light pulse wave form, the streamer and leader shape on the still photograph. The light pulses were measured by photo-multipliers PM1 and PM2 through the slit (the open range at the gap axis was  $0.8 \times 60 \text{ mm}$ ) at any position along the gap axis. The slit positions of PM1 and PM2 are indicated by distance  $x$  along the gap axis from the rod tip position (as the origin). The voltage and current wave form were observed by type 507 Tektronics oscilloscope.

### 3. Delayed Streamer

#### 3.1. Positive polarity

For a constant gap length  $\delta = 5 \text{ cm}$ ,  $\rho = 0.5 \sim 7.5 \text{ mm}$ , the current wave form against the positive impulse voltage (50 % flashover voltage) can be classified according to features as follows:

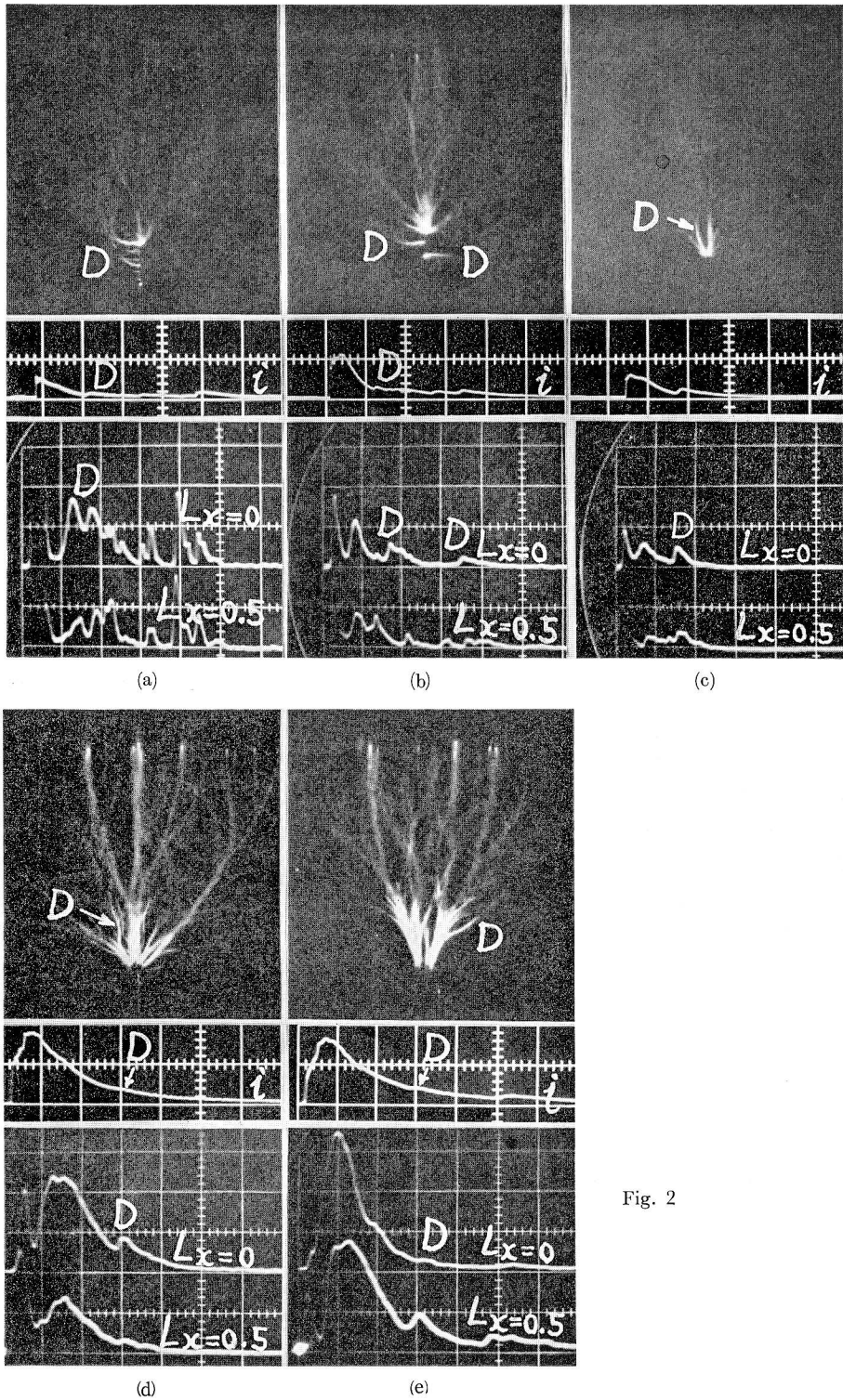

Fig. 2

- (1) Only one current pulse appears
- (2) Following the first current pulse, one or more smaller pulses appear.
- (3) Flashover

The still photograph, the current wave form and the light pulse recorded simultaneously in case (2) is shown in Fig. 2. The peaks after the second one in the current wave correspond to the bright portion near the rod electrode and to the peaks after the third one of the light pulse (with symbol D in Fig. 2). In the case of  $\rho=0.5$ , 1 mm, the discharge corresponding to these peaks occurred from the root of the rod electrode. For  $\rho=2$  mm and the above, the discharge portion occurs at the part corresponding to that of the first peak. For  $\rho=2$  mm, the same measurements were carried out for  $\delta=5, 10, 15, 20$  cm and the results obtained

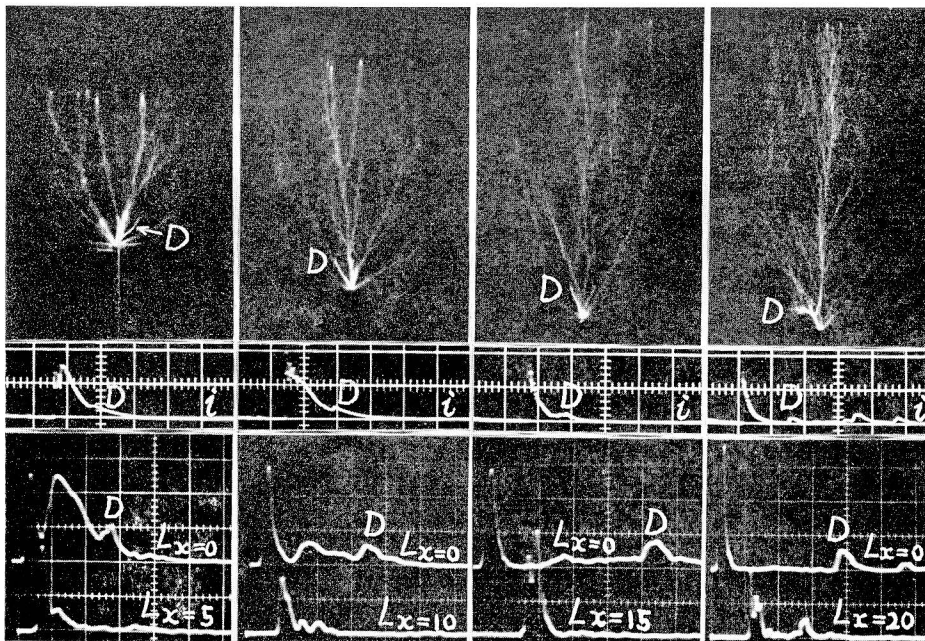

Fig. 3. Still photograph, current and light pulse caused by delayed streamer for different  $\delta$ .  $\rho=2$  mm, rod positive.

- (a)  $\delta=5$  cm,  $V_p=48.3$  kV, current: 1.48 A/div., 0.2  $\mu$ s/div., light: 0.1  $\mu$ s/div.
- (b)  $\delta=10$  cm,  $V_p=75.9$  kV, current: 1.48 A/div., 0.2  $\mu$ s/div., light: 0.1  $\mu$ s/div.
- (c)  $\delta=15$  cm,  $V_p=104$  kV, current: 1.48A/div., 0.5  $\mu$ s/div., light: 0.1  $\mu$ s/div.
- (d)  $\delta=20$  cm,  $V_p=131$  kV, current: 1.48A/div., 0.5  $\mu$ s/div., light: 0.2  $\mu$ s/div.

Fig. 2. Still photograph, current and light pulse for different  $\rho$ .  $\delta=5$  cm, rod positive.

- (a)  $\rho=0.5$  mm,  $V_p=57.0$  kV, current: 1.23 A/div., 0.2  $\mu$ s/div., light: 0.2  $\mu$ s/div.
- (b)  $\rho=1$  mm,  $V_p=57.0$  kV, current: 1.23 A/div., 0.2  $\mu$ s/div., light: 0.2  $\mu$ s/div.
- (c)  $\rho=2$  mm,  $V_p=55.2$  kV, current: 1.23 A/div., 0.2  $\mu$ s/div., light: 0.2  $\mu$ s/div.
- (d)  $\rho=4$  mm,  $V_p=51.5$  kV, current: 1.23 A/div., 0.1  $\mu$ s/div., light: 0.1  $\mu$ s/div.
- (e)  $\rho=7.5$  mm,  $V_p=57.0$  kV, current: 1.23 A/div., 0.1  $\mu$ s/div., light: 0.1  $\mu$ s/div.

are shown in Fig. 3. Similarly to that in Fig. 2, the peaks after the second one in the current wave correspond to the bright portion of the channel on the still photograph and the peaks after the third one in the light pulse. When these peaks appear, the bright part around the rod electrode shifts as shown in Fig. 4. In other words, for  $\delta=5$  cm, the wave form of the light pulse is very complicated and difficult to trace (Fig. 4(a)). For  $\delta=15$  cm, the shifting of the light emission

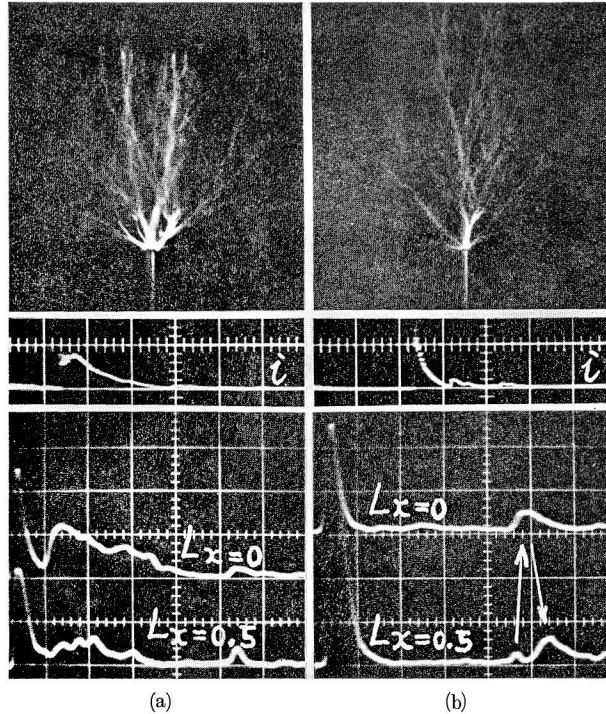

Fig. 4. Shift of light pulse by the occurrence of delayed streamer.  $\rho=2$  mm, rod positive.  
 (a)  $\delta=5$  cm,  $V_p=48.3$  kV, current: 1.48 A/div., 0.2  $\mu$ s/div., light: 0.1  $\mu$ s/div.  
 (b)  $\delta=15$  cm,  $V_p=104$  kV, current: 1.48 A/div., 0.5  $\mu$ s/div., light: 0.1  $\mu$ s/div.

appears clearly (Fig. 4 (b) with arrow sign). By comparing the results by the photograph, current and light pulse, these data could be considered as a set of primary and secondary streamers (PS & SS). (Refer to  $L_{x=0.5}$ .) In this section, this phenomenon is referred as to the delayed streamer (abbreviated as the DS hereafter). From the light pulse shown in Fig. 4 (b), it is deduced that the DS is formed by the PS from the gap to the rod electrode and the SS on the same path from the rod electrode towards the gap space.

Under the same conditions as in Fig. 3, the  $T$ 's are defined as follows;

- $T_0$ : the time interval between the first PS and the occurrence of the DS
- $T_1$ : the time between the occurrence of the PS and its arrival at the plane electrode
- $T_2$ : the time interval between the arrival of the PS at the plane and the occurrence of the DS

Hence, it is deduced that  $T_0 = T_1 + T_2$ . The variations of  $T_0$ ,  $T_1$  and  $T_2$  are almost proportional to  $\delta$  as shown in Fig. 5. Among these, so long as the speed of the PS does not change,  $T_1$  varies proportional to  $\delta$ . Here, we assume a certain wave propagating from the plane electrode to the rod electrode. From Fig. 5, the value of  $\delta/T_2$ , which has the dimension of speed, was calculated to be  $4 \sim 5 \times 10^7$  cm/s. On the other hand, the upper limit of the group velocity of the transmissibility of an electronic static wave in plasma<sup>7)</sup> is determined by the thermal velocity of electron  $V_{th} = \sqrt{3kT_e m_e}$ . Assuming  $T_e = 1$  eV,  $V_{th}$  is equal to  $5.9 \times 10^7$  cm/s which agrees well with the above value. In the experiment for the

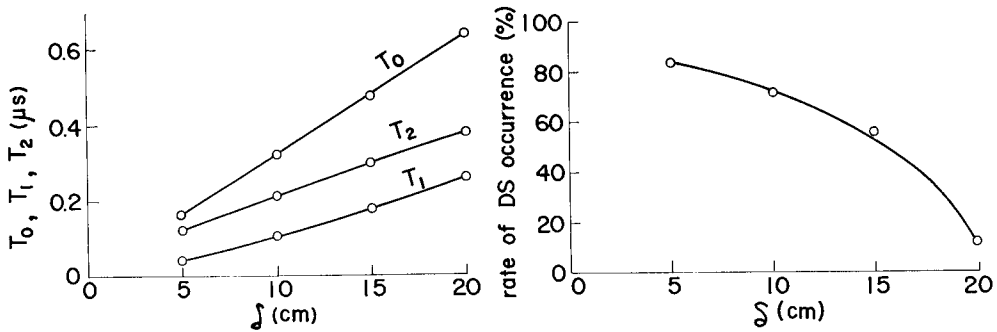

Fig. 5.  $T_0, T_1, T_2$  vs.  $\delta$  at 50% FO voltage.  $\rho = 2$  mm, rod positive.

Fig. 6. Rate of occurrence of delayed streamer at 50% FO voltage.  $\rho = 2$  mm, rod positive.

region  $x > 1$  cm, the shifting of light emission corresponding to this propagation was not observed. Hence, even if the wave propagation exists, it will probably be very weak and may not be accompanied by any ionization or light emission. Under the same condition as stated in Fig. 3, excepting the flashover (abbreviated as FO hereafter), the rate of development of the DS is shown in Fig. 6. For a large  $\delta$ , if the DS propagates, it can lead to the FO very easily. For a small  $\delta$ , however, even if the DS propagates, in most cases, it does not lead to the FO.

### 3.2. Negative polarity

In the case where the voltage polarity is negative, when a voltage which is about 50% FO voltage is applied, the formation of the DS can be observed. Fig. 7

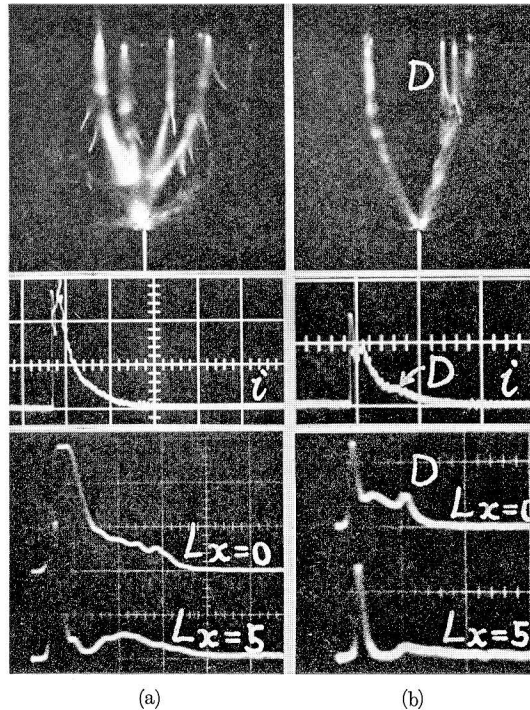

Fig. 7. Delayed streamer in the case of negative polarity.  
 $\rho=2$  mm,  $\delta=5$  cm,  $V_p=82.8$  kV, rod negative.  
 (a) current: 2.47 A/div., 0.2  $\mu$ s/div., light: 0.1  $\mu$ s/div.  
 (b) current: 2.47 A/div., 0.2  $\mu$ s/div., light: 0.2  $\mu$ s/div.

shows a case where 50 % FO voltage is applied across a gap of  $\rho=2$  mm,  $\delta=5$  cm. The DS will surely appear on the photograph if the second peak of the current wave appears. But the reverse is not true. Namely, in a reverse case, the magnitude of the current of the PS is very large. Fig. 7 (a) shows a case where there is no corresponding peak to the DS, while Fig. 7 (b) shows a case where a corresponding peak exists. In either case, the DS was observed in the form of branching of the SS near the anode moving towards the cathode along the first PS discharge channel.

#### 4. Inception and Development of the Positive Leader

##### 4.1. The process of leader occurrence

Taking many photographs of the DS (except FO) in occurring cases when the impulse voltages with the same wave form and the same peak value (50 % FO voltage) were applied to the gap ( $\rho=2$  mm,  $\delta=5$  cm), and arranging them in the order of low to high voltage at the appearing instants, Fig. 8 (a)~(c) were



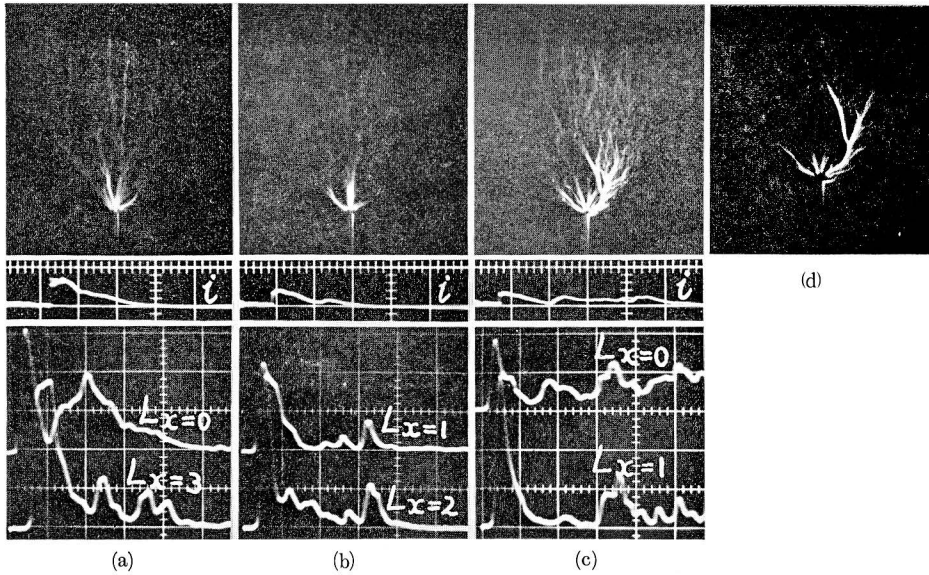

Fig. 8. Delayed streamer vs. instantaneous voltage of PS appearance.  $\rho=2$  mm,  $\delta=5$  cm,  $V_p=48.3$  kV, current: 1.48A/div., 0.2  $\mu$ s/div., light: 0.1  $\mu$ s/div.  
 (a)  $V_s=35.5$  kV  
 (b)  $V_s=28.6$  kV  
 (c)  $V_s=24.4$  kV

obtained. From these figures, when  $V_s$  is low, the first PS and the accompanied SS are weak, but the DS develops well, and the current corresponding to the pulse group continues without interruption. Fig. 8 (d) is an enlarged figure of that of (c). As the DS develops, the inner part of the discharge channel becomes very bright. In the experiment with varying  $\rho$  for  $\rho \geq 2$  mm, if the current pulse of the DS continues without interruption, the thin and very bright channel forms within the discharge channel. Compared with the result obtained by a chopped wave application, as described later, this channel is similar to that of the leader formed when the chopping time is very short. As a result, it is thought that it may be the beginning of a leader. In the case of  $\rho=0.5, 1$  mm, it is concluded from Fig. 2 that the continuity of the current pulses ends with the repetition of the DS. In this case, by applying as an overvoltage rate  $\Delta=10\%$  and by chopping the voltage, Fig. 9 was obtained. It can be seen in the case of  $\rho=0.5, 1$  mm, that only after the repetition of several DS's, the leader begins to be formed.

As described above, the DS is formed by combining the PS and the SS. The latter is the continuation of light emission due to the action of the electric field applied to the former. From the photograph, the discharge channel of the PS and SS is diverging, but that of the leader is converging<sup>9)</sup>. Consequently, the whole process can be explained by the transition of the diverging PS discharge

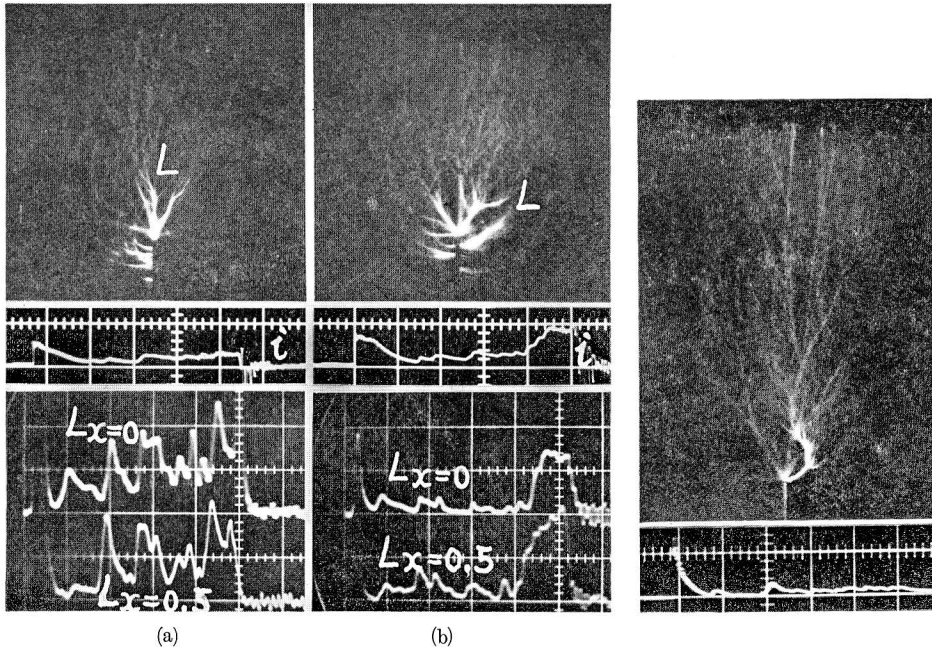

Fig. 9. Initial stage of leader formation in the case of  $\rho=0.5$ , 1 mm.  $\delta=5$  cm, rod positive, chopped voltage.  
 (a)  $\rho=0.5$  mm,  $V_p=62.5$  kV, current: 1.23 A/div., 0.2  $\mu$ s/div., light: 0.2  $\mu$ s/div.  
 (b)  $\rho=1$  mm,  $V_p=64.4$  kV, current: 1.23 A/div., 0.2  $\mu$ s/div., light: 0.2  $\mu$ s/div.

Fig. 10. Initial stage of leader formation in the case of  $\rho=2$  mm,  $\delta=15$  cm, rod positive,  $V_p=104$  kV, current: 1.48 A/div., 0.5  $\mu$ s/div.

channel via the SS to the leader. In other words, for both the first streamer and the delayed streamer,

$$\text{PS} \xrightarrow{\text{field}} \text{SS} \xrightarrow{\text{converging}} \text{leader}$$

Even if  $\delta$  becomes large (10, 15, 20 cm) for  $\rho=2$  mm, the same leader could be observed as for  $\delta=5$  cm when the current value does not descend to zero, and the following pulses appear. Fig. 10 shows a case where  $\delta=15$  cm.

## 4.2. The process of leader development

### <4.2.1> Still photograph

When the overvoltage ( $d=10\%$ ) was applied to the gap ( $\rho=2$  mm,  $\delta=5$  cm) and was chopped at a suitable time ( $T_c=0.5\sim 1.5$   $\mu$ s), the still photographs and the current wave were obtained as shown in Fig. 11. By chopping off the applied voltage at the moment when the current of the DS is increasing sharply, the obtained photograph Fig. 11 (a) shows the existence of a branching at the tip of the leader which is about 1 cm long. Although the tip of this branch is not

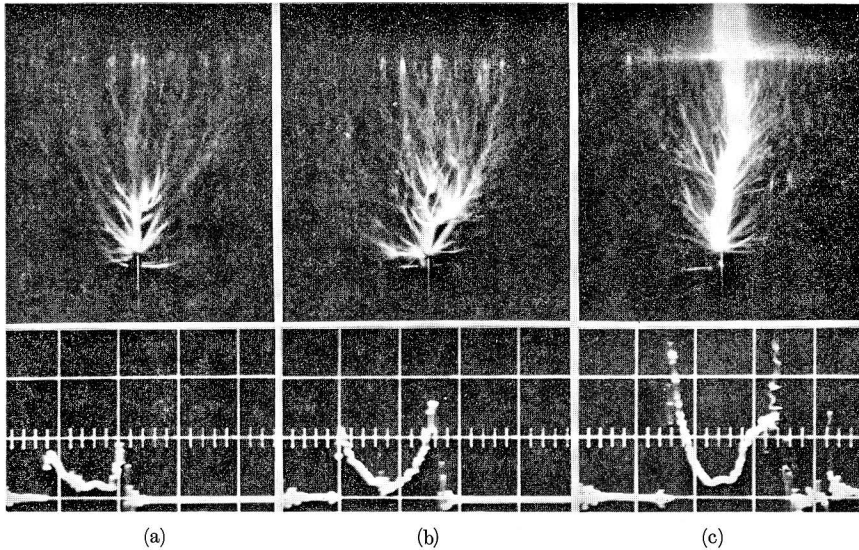

Fig. 11. Development of leader. Chopped voltage.  $\rho=2$  mm,  $\delta=5$  cm, rod positive,  $V_p=62.1$  kV, current: 2.96 A/div.,  $0.5 \mu\text{s}/\text{div}$ .

- (a)  $T_c=1.1 \mu\text{s}$   
 (b)  $T_c=1.4 \mu\text{s}$   
 (c)  $T_d=1.75 \mu\text{s}$

bright, a few mm length part at the stem is strongly illuminated and is similar to the DS in that appearance. Some of these branches have thin filament inside their channels. On the other hand, on the stem portion, the channel formation can be seen as usual. For a further increase of the current (Fig. 11 (b)), the stem of the leader has several branches and, in addition, from each one, the branches develop again. This means the branching off from the branch at the tip of the leader once more, and the early branches become a part of the leader stems. Thus, from the tip of the leader, new groups of streamers (LS) develop continuously and extend out constantly. In Fig. 9 (a), even if the group of the streamer exists at the tip of the leader, the bright thin filament inside the stem can not be observed in the case where the rod diameter is very small. Hence, during the leader development, the stem of the channel is formed only after its branching.

In Fig. 12, for  $\delta=15$  cm, during the leader development (as shown in Fig. 12 (a)→(b)→(c)), the light quantity of the whole gap increases. This is due to the fact, as described above, that as the leader develops, with repeating branching, a large number of streamers develop. The branching and development of the leader is step-wise in nature, and the current pulse corresponding to each LS to be appeared. However, because the numerous small current pulses were superimposed on the current wave, a rather smooth pulse was observed.

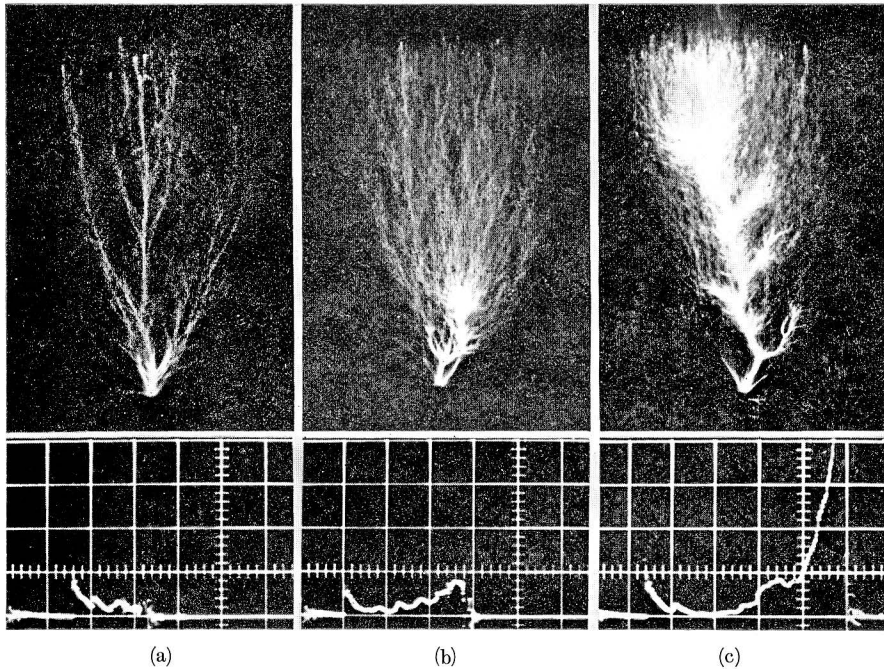

Fig. 12. Development of leader:  $\rho=2$  mm,  $\delta=15$  cm, chopped voltage, rod positive,  $V_p=117$  kV, current: 2.96 A/div.,  $0.5 \mu\text{s/div.}$

- (a)  $T_c=1.6 \mu\text{s}$
- (b)  $T_c=1.9 \mu\text{s}$
- (c)  $T_c=3.0 \mu\text{s}$

#### 〈4.2.2〉 Light pulse

Fig. 13 shows the light pulses  $L_{x=1}$  and  $L_{x=10}$  during the leader development in the case where  $\rho=2$  mm,  $\delta=10$  cm. The parallel shift of the light pulse shown

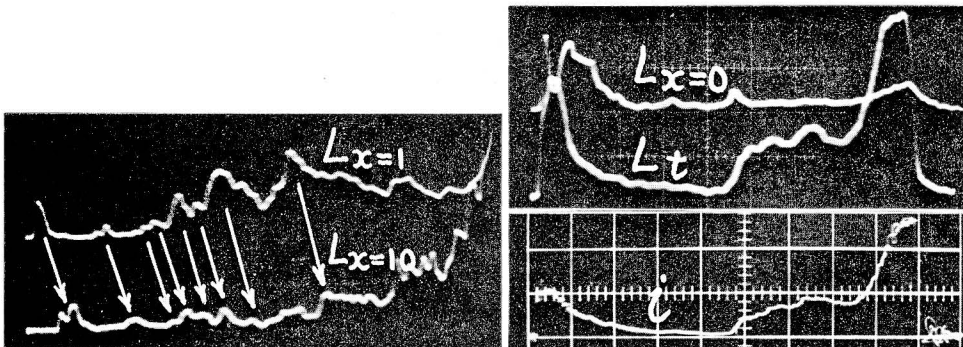

Fig. 13. Shift of light pulses for leader development:  $\rho=2$  mm,  $\delta=10$  cm, rod positive,  $V_p=89.7$  kV. upper trace:  $x=1$  cm, Lower trace:  $x=10$  cm, sweep:  $0.2 \mu\text{s/div.}$

Fig. 14. Comparison of light pulse and current wave form for leader development:  $\rho=2$  mm,  $\delta=10$  cm, rod positive.  $V_p=89.7$  kV, current: 2.96 A/div.,  $0.2 \mu\text{s/div.}$ , light:  $0.2 \mu\text{s/div.}$

by the arrow in the figure indicates that the streamer propagating from the leader tip reaches the plane electrode. Fig. 14 shows the light pulse  $L_{x=0}$ , the light pulse from the whole gap  $L_t$  and the current wave form  $i$ , where,  $L_t$  can be obtained by removing the slit of PM2 so that the light from any position in the gap space can be caught. In this figure, the wave forms of  $L_{x=0}$  and of  $i$  are not similar to each other, but  $L_t$  and  $i$  are similar.

#### 〈4.2.3〉 The path of streamers

As described above, the breakdown phenomenon starts with the primary streamer inception, then propagates with the delayed streamer and with the streamer from a leader tip. When the slit of PM1 is set at  $x=0$  and PM2 is set at the middle of the gap with a pinhole having a diameter 0.5 mm (converted area into the position of the gap), and when  $\Delta=13\%$  overvoltage was applied to the gap ( $\rho=2$  mm,  $\delta=15$  cm), the output of PM1 and PM2 ( $L_{x=0}$  and  $L_h$ ) are shown in Fig. 15. During the several steps of the leader development after the passing of the first PS across the pinhole (Fig. 15 (a)), no existence of the LS at the position of the pinhole is certified. On the contrary, in the case where no first PS passes across the pinhole (Fig. 15 (b)), after the several steps of the leader development, the existence of the LS is certified by the PM2 output ( $L_h$ ). By considering the photographs described at the preceding sections, it is deduced that the first PS, the DS, and the LS all propagate on different paths.

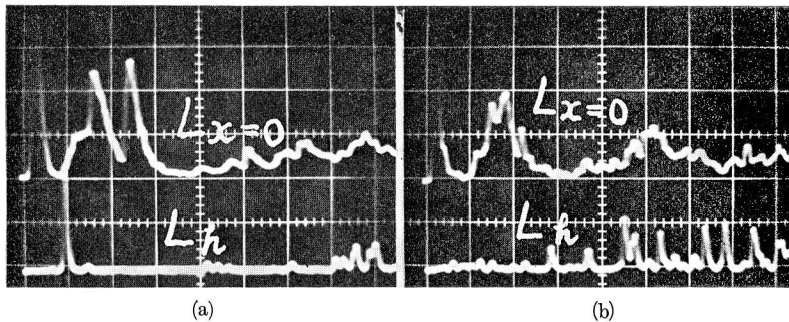

Fig. 15. Light pulses obtained by using slit ( $x=0$  cm) and a pinhole ( $x=10$  cm):  $\rho=2$  mm,  $\delta=15$  cm, rod positive,  $V_p=117$  kV. upper trace:  $L_{x=0}$ , lower trace:  $L_h$ , sweep:  $0.2 \mu\text{s}/\text{div}$ .

#### 〈4.2.4〉 Streamer arrival at the cathode surface

On the cathode surface shown in Fig. 12, an X-ray film was placed and the chopped wave voltages were applied. The current wave form, the still photograph and the streamer trace on the cathode surface in this case are shown in Fig. 16. Comparing this photograph with Fig. 12, both results are almost identical and the self-development of the leader in the long gaps can also be observed in gap lengths

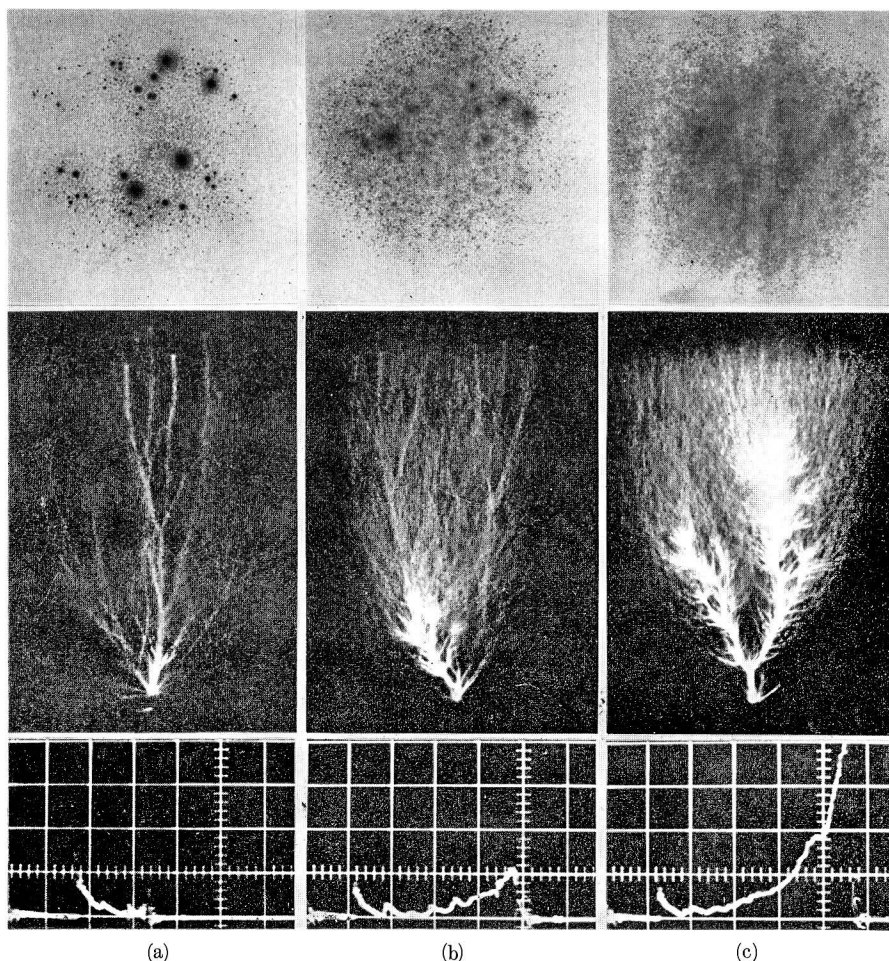

Fig. 16. Comparison of current, still photograph, and the marks of streamers on cathode surface for leader development.  $\rho=2$  mm,  $\delta=15$  cm, rod positive,  $V_p=117$  kV. Chopped voltage. current: 2.96 A/div.,  $0.5 \mu\text{s}/\text{div}$ .

(a)  $T_c=1.7 \mu\text{s}$

(b)  $T_c=2.5 \mu\text{s}$

(c)  $T_c=2.9 \mu\text{s}$

less than 20 cm, where self-development means a leader development without any assistance of electron emission from the cathode. From the features of the streamer trace on the X-ray film, (i) even if the leader approaches near the cathode, no outstanding mark could be found. This implies that the streamer channels do not exist for a long time and that the single and long streamer itself does not change into a leader. Rather, many sets of streamers and leaders occur sequentially in step-wise manner and bridgeover the gap lastly. It also implies that the leader is not a channel developed from a big streamer. (ii) There are very

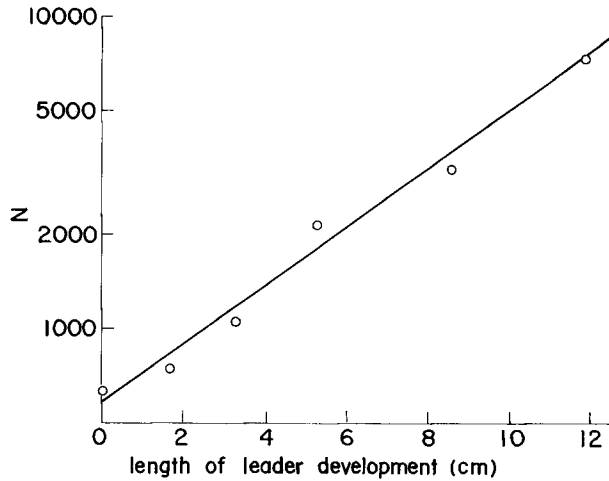

Fig. 17. Number of streamers arriving at the cathode vs. the length of leader development.  $\rho=2$  mm,  $\delta=15$  cm,  $V_d=117$  kV, rod positive.

few marks of strong streamers (about 10) and this number is about equal to that before the stage where the leader is formed.

Fig. 17 shows the number of marks on the film versus the leader length. The number of streamers arriving at the cathode increases exponentially against the leader length.

**<4.2.5> The cathode effect on the leader development**

In the previous section, the cathode was covered with an X-ray film and the high voltage was applied to the gap. Hence, it appears that the role of the cathode in the leader development is not very important. However, the X-ray film is not an absolute insulator, so, other kinds of insulation plate were used and the same experiment was executed to investigate the insulator effect on the cathode. The features of the insulator used here are shown in Table 1.

Table 1. Some characteristics of film and insulator used.

	X-ray film	insulation plate	
thickness	0.2 mm	0.8 mm	3 mm
surface resistivity	$1\sim 9 \times 10^{12} \Omega \cdot \text{cm}$	$10^{15} \Omega \cdot \text{cm} <$	$\approx 7 \times 10^{16} \Omega \cdot \text{cm}$
material	Polyester	PVC	Acrylite

Fig. 18 shows the result of a case where a gap of  $\rho=2$  mm,  $\delta=15$  cm was used in this experiment. By using an insulating plate (Fig. 18 (a)), the leader development mostly stopped at the first or second stage in this experiment, but

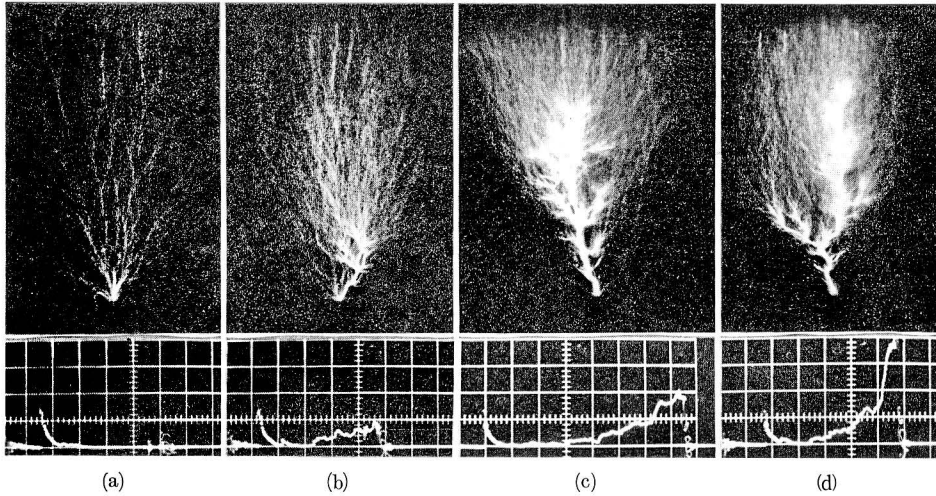

Fig. 18. Role of the cathode for the leader development.  $\rho=2$  mm,  $\delta=15$  cm, rod positive,  $V_p=117$  kV. Chopped voltage. (a), (b), (c): Cathode covered with insulating sheet (3 mm in thickness) (d): no insulating sheet.  
 (a)  $T_c=3.0$   $\mu$ s, current: 1.48 A/div., 0.5  $\mu$ s/div.  
 (b)  $T_c=2.9$   $\mu$ s, current: 1.48 A/div., 0.5  $\mu$ s/div.  
 (c)  $T_c=4.8$   $\mu$ s, current: 2.96 A/div., 0.5  $\mu$ s/div.  
 (d)  $T_c=3.4$   $\mu$ s, current: 2.96 A/div., 0.5  $\mu$ s/div.

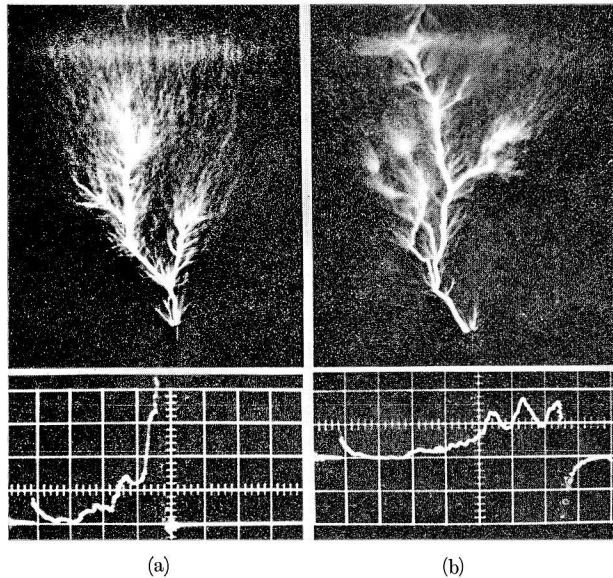

Fig. 19. Effect of insulator thickness for leader development.  $\rho=2$  mm,  $\delta=10$  cm, rod positive,  $V_p=89.7$  kV. Chopped voltage. current: 2.96 A/div., 0.5  $\mu$ s/div.  
 (a) insulator thickness 0.8 mm,  $T_c=2.4$   $\mu$ s  
 (b) insulator thickness 3 mm,  $T_c=3.8$   $\mu$ s



the leader sometimes develops completely (Fig. 18 (b), (c)). Comparing the cases with and without an insulation plate, the current increases more slowly in the former. This is because the charges accumulate on the insulator surface and make an opposite field which could be considered as having the same effect as lowering the applied voltage. This opposite field effect varies according to the thickness of the insulator. Fig. 19 shows the experimental results in the case of a gap of  $\rho=2$  mm,  $\delta=10$  cm. In Fig. 19 (a) and (b), insulators have a 0.8 mm and 3 mm thickness respectively. The current increase is slower in the latter case. Further, in both cases, the current wave form shows a distinct pulsation which also would be due to the opposite field effect.

For the gap of  $\rho=2$  mm,  $\delta=5$  cm, using insulators of 0.8 mm in thickness (Fig. 20 (a)) and 3 mm (Fig. 20 (b)), all the features those were found previously in the cases of  $\delta=15, 10$  cm, appear here. However, since  $\delta$  is small, the effect

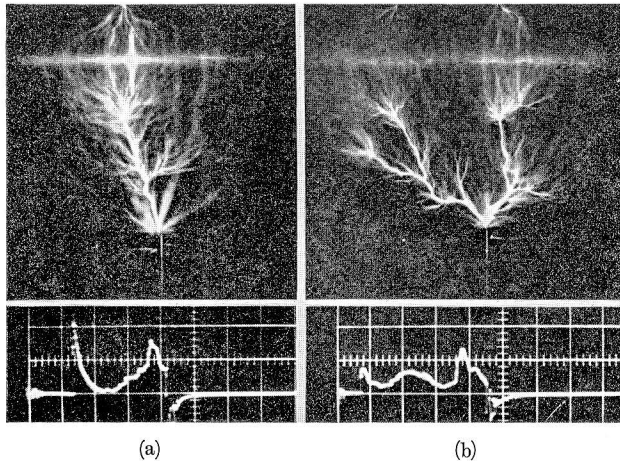

Fig. 20. Effect of insulator thickness for leader development.  $\rho=2$  mm,  $\delta=5$  cm, rod positive. Chopped voltage. current: 2.96 A/div., 0.5  $\mu$ s/div.  
 (a) insulator thickness 0.8 mm,  $V_p=62.1$  kV,  $T_c=2.1$   $\mu$ s  
 (b) insulator thickness 3 mm,  $V_p=69.0$  kV,  $T_c=2.3$   $\mu$ s

of the opposite field becomes stronger and the required voltage for the leader development is about 10 % higher than that in Fig. 20 (a). By further comparison of these two figures, it can be observed that the discharge space in Fig. 20 (b) tends to diverge such as a parachute, probably owing to the opposite field effect at the insulator surface. Thus, if the cathode surface is covered by an insulator, the leader occurrence and its development are slightly suppressed compared with

a surface without insulation. As a result, for a short gap of about 5 cm, it is deduced that the leader extends itself without any assistance from the cathode emission.<sup>11)</sup>

### 4.3. Types of the leader occurrence and development characterised by the current wave form

The leader occurrence, development and their mechanism have been described in an earlier section. Comparing the still photograph with the current wave form, the leader occurrence and development can be divided into 2 or 3 categories. In addition, the moment of its occurrence and the shape can be predicted from the characteristic of the current wave form. Fig. 21 shows the three typical forms of the leader at the occurring stage. In the figure,

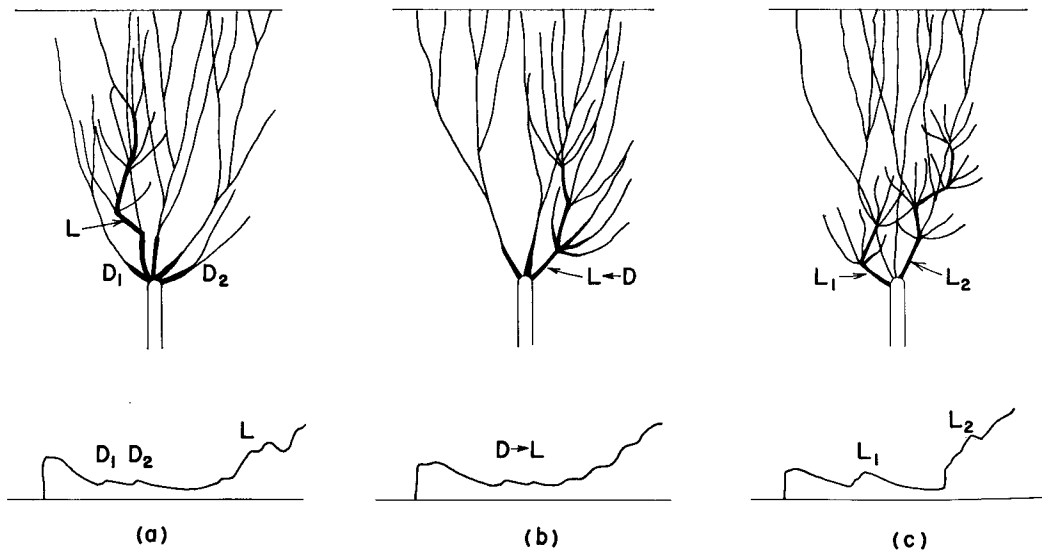

Fig. 21. Typical forms of leader at the initial stage.

- a) Multiple DS develop and the first PS or one of the DS grows and becomes the leader as can be seen in the case of  $\rho=0.5, 1$  mm.
- b) One DS develops and grows up to become a leader and this can be seen in the case of  $\rho \geq 2$  mm.
- c) The same as b) i.e. one DS changes to the leader and in the process of changing, another leader begins to develop and the first leader stops growing.

As regards the types of leader development, there exist 2 types as shown in Fig. 22. From the observation of these figures:

- a) Pulsated increase of current. This is commonly observed in cases when  $\delta$

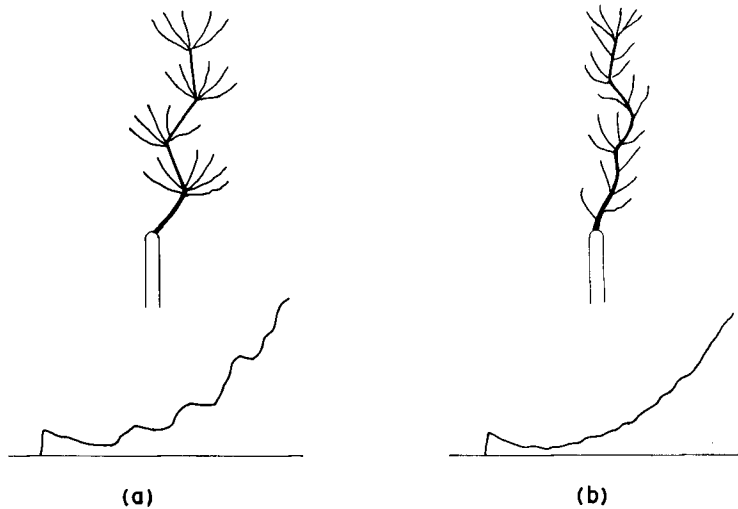

Fig. 22. Typical forms of leader at the development stage.

is small ( $\delta \leq 5$  cm), or the series resistance to the gap is high<sup>9)</sup> (above 10 k $\Omega$ ).

- b) Gradual increase of current. This is commonly observed in cases of a long gap with a low series resistance to the gap.

In the actual process of the discharge, the phenomena are determined by a combination of these types at each stage of the occurrence or development of a leader.

### 5. The Occurrence and Development of the Leader in Negative Polarity

Since the FO voltage against a negative impulse is about 50~60 % higher than that of the positive for the gaps used in this study, the positive leader is always ready to develop from the anode side in this case. Hence, the FO mechanism of a negative polarity is much more complicated than that of a positive polarity. For instance, it is reported that for the same gap, and for the over-voltage rate change, there exist 5 kinds of FO processes.<sup>10)</sup> Here, only the FO process of applying  $\Delta=5$  % overvoltage across a gap of  $\rho=2$  mm,  $\delta=5$  cm was studied. The experimental results are shown in Fig. 23, where the applied voltage was chopped off.

Fig. 23(a) Following the first PS, several DS develop. The DS in this case has a characteristic of propagating towards the cathode after separating from the SS developed in the middle of the gap or near the anode.

Fig. 23(b) The occurrence of a leader. Unlike the situation in a positive po-

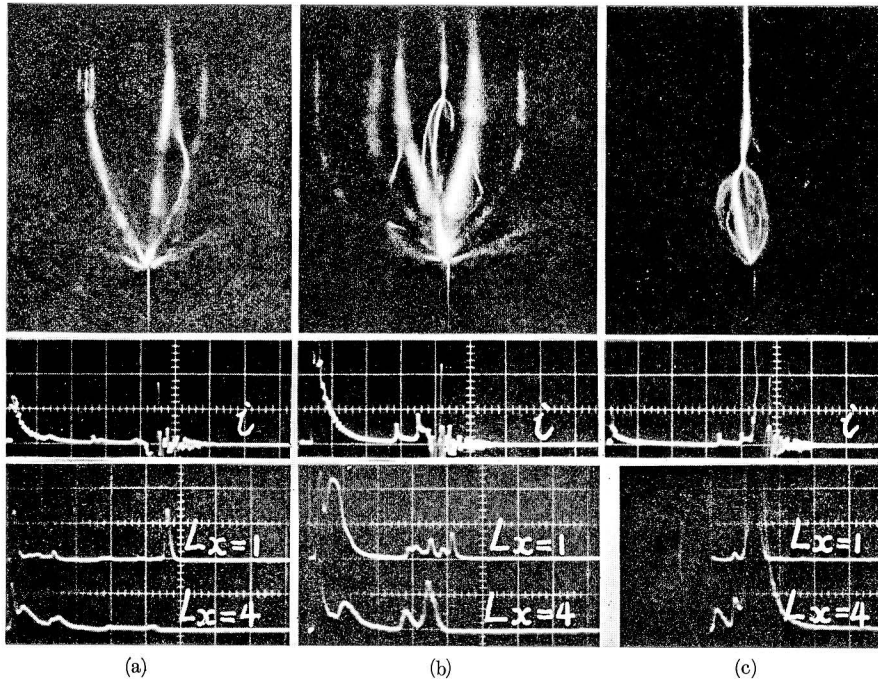

Fig. 23. Initial stage of leader development for negative polarity.  $\rho = 2$  mm,  $\delta = 5$  cm,  $V_p = 96.6$  kV. Chopped voltage. current: 2.47 A/div., 0.2  $\mu$ s/div., light: 0.2  $\mu$ s/div.

larity, the mid gap leader appears in the vicinity of the plane (about 8 mm away from the plane). The current wave form is the same as that in a positive polarity; i.e. before the appearance of the leader, there exists a discontinuity in the pulse group. However, after the stage of a leader appearance, the pulse groups are connected without a break.

Fig. 23(c) The leader develops further. In this instance, the leader develops from the plane towards the rod electrode and a large number of streamers (LS) can be observed near the rod tip.

In the process described above, the positive leader incepted from the plane electrode, and causes a flashover across the gap.

Fig. 24 shows 3 types of positive leaders at the initial stage in a negative polarity. From this figure, the following are deduced:

- a) The PS growing near the plane in its inception becomes SS and then changes to a leader.
- b) The DS near the plane is drawn up to the plane and further developed into a leader.
- c) From the region of the plane electrode, where the first PS does not reach, a DS appears and changes into a leader.

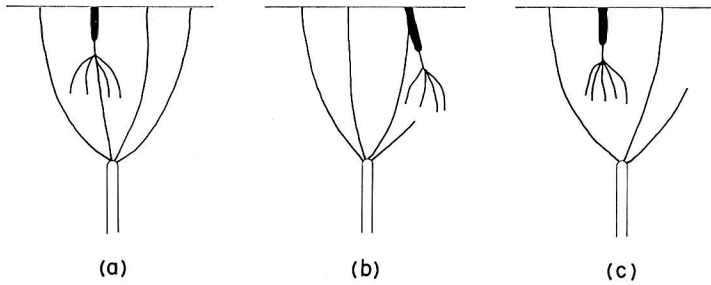

Fig. 24. Three types of positive leader formation for negative polarity.

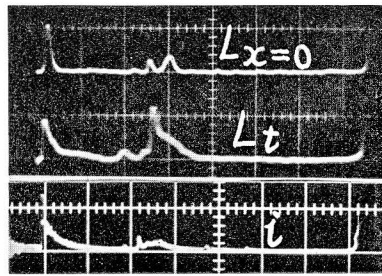

Fig. 25. Comparison of light pulses and current wave form for leader development.  $\rho=2$  mm,  $\delta=5$  cm, rod negative.  $V_p=96.6$  kV. light (upper and middle trace):  $0.2 \mu\text{s/div.}$ , current (lower trace):  $2.47 \text{ A/div.}$ ,  $0.2 \mu\text{s/div.}$

In each of the above cases the root part of the DS is diverging at first, but as the leader develops, the thin and bright channel in the DS begins to form a leader.

Fig. 25 shows the light pulses  $L_{x=0}$ ,  $L_t$ , and the current wave form during the leader development. Corresponding to the first PS,  $L_t$  appears to be relatively smaller than the one at  $i$ , but excepting this point, it is the same as that in the positive polarity, i.e.  $i$  does not agree with  $L_{x=0}$ , but agrees with  $L_t$ .

### 6. The Type of Electrical Breakdown

By combining the experimental results, the electrical breakdown of atmospheric air against the impulse voltage can be classified into 2 types.

1). Short gap type

$$\text{Electron avalanche} \rightarrow \text{PS} \xrightarrow{\text{field}} \text{SS} \xrightarrow{\text{converge}} \text{Arc}$$

2). Long gap type

$$\text{Electron avalanche} \rightarrow (\text{PS} \xrightarrow{\text{field}} \text{SS} \xrightarrow{\text{converge}} \text{leader}) \rightarrow \text{Arc}$$

The phenomenon within the bracket in above sequence is repeated until the gap is bridged by the leader. The difference between short and long gaps lies in the

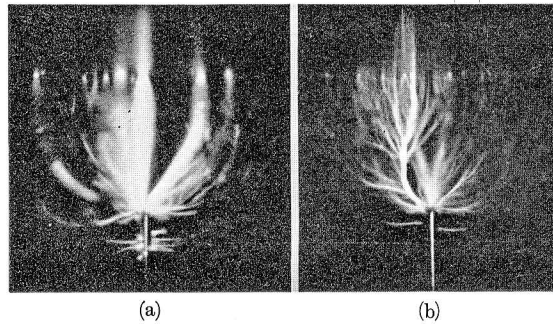

Fig. 26. Examples of different types of breakdown in the same gap.  
 $\rho=2$  mm,  $\delta=3$  cm, rod positive.  
 (a)  $V_p=69.0$  kV  
 (b)  $V_p=51.8$  kV

bridging over the gaps by SS or not. In the former case, the first SS bridges the gap, while in the latter, the SS does not bridge the gap. Whether the breakdown belongs to a long or short gap type depends on the applied voltage. Fig. 26 shows a typical example of resulting phenomena when the positive impulse voltages of various values are applied. Fig. 26(a) shows a case, where the voltage peak value and the instantaneous voltage of SS appearance is high, and the gap is bridged by the SS. Fig. 26(b) shows, however, that because the peak value and the voltage at the instant of appearance are low, no bridgeover by the SS takes place.

## 7. Conclusion

In this study, applying impulse voltage across a rod-plane gap, the process from the streamer occurrence up to the leader development was investigated experimentally. The results are summarized as follows:

1) Following a primary streamer (PS) and a secondary streamer (SS) occurrence, several delayed streamers (DS) develop, where the DS has been found and defined here. Each DS is constructed from the combination of the PS and the SS.

2) The time interval between the occurrence of the first PS and that of the DS is proportional to the gap length.

3) Only when the current pulses of the DS continue without interruption, the leader occurs against both positive and negative voltage applications on the rod electrode. On the still photographs of predischARGE, it is possible to observe the leader of the filament form within the SS channel.

4) From the tip of the leader, the streamer groups (LS) occur and develop

continuously. The root of each LS becomes SS and about half of them are formed by the thin channel within the LS channels.

5) The first PS, the DS and LS all take different paths.

6) Even if the cathode is covered with an insulating sheet, the leader occurrence can be observed. Hitherto, the long gaps of 30~40 cm length and above have been known to possess a self-development property of a leader. This property was also ascertained for a short gap between 3~20 cm length.

7) At the stage of the leader development for both positive and negative voltage applications, the light pulse of the whole gap space has the same form as the current wave.

Lastly, this study was executed with the kind and useful advice of Prof. Uenosono et al. and the aid of the financial support from the Scientific Research Fund of the Department of Education, Japanese Government. The authors would like to express their great gratitude for all the kind assistances received.

#### References

- 1) Hudson, G. G., and Loeb, L. B.: *Phys. Rev.* Vol. 123 (1961) 29.
- 2) Dawson, G. A.: *J. Appl. Phys.* Vol. 36 (1965) 3391.
- 3) Acker, F. E., and Penney, G. W.: *J. Appl. Phys.* Vol. 39 (1968) 2363.
- 4) Park, J. H., and Cones, H. N.: *J.R.N.B.S.* Vol. 56 (1956) 201.
- 5) Akazaki, M., Hara, M., and Soma, K.: *Trans. I.E.E. Japan* Vol. 92-A (1972) 553.
- 6) Saxe, J. H., and Meek, J. M.: *P.I.E.E.* Vol. 102-C (1955) 221.
- 7) Takeda, S.: *Foundation of Plasma Physics*, Asakura shoten (1969).
- 8) Oh. C. H., Hayashi, M., and Uenosono, C.: *Material of Discharge Seminar ED-74-15* (1974).
- 9) Hosokawa, T., and Miyoshi, Y.: *Material of Discharge Seminar ED-72-16* (1972).
- 10) Tsuneyasu, I., and Akazaki, M.: *Trans. I.E.E. Japan* Vol. 93-A (1973) 487.
- 11) I. E. E. Japan: *Handbook of Discharge Phenomena*, Ohm-sha (1974) p. 181.