



TITLE:

On a Generalized Problem of Disc Electrodes I

AUTHOR(S):

KIYONO, Takeshi; SHIMASAKI, Masaaki

CITATION:

KIYONO, Takeshi ...[et al]. On a Generalized Problem of Disc Electrodes I. *Memoirs of the Faculty of Engineering, Kyoto University* 1969, 31(2): 231-236

ISSUE DATE:

1969-06-30

URL:

<http://hdl.handle.net/2433/280774>

RIGHT:

On a Generalized Problem of Disc Electrodes. I.

By

Takeshi KIYONO* and Masaaki SHIMASAKI*

(Received December 20, 1968)

A problem of disc electrodes is discussed on the basis of dual integral equations both for an electrostatic problem and for a steady current field problem in the unified manner. It is shown that two well-known problems,

- 1) the plate condenser problem and
 - 2) the disc electrode problem for steady current
- may be treated as special cases.

1. Introduction

Although the method of series expansion of potential in eigenfunctions is powerful for the Dirichlet and Neumann problem of Laplace's equation, it is usually difficult to determine coefficients of series expansion for mixed boundary value problems in which two or more boundary conditions are involved. Some important classes of mixed boundary value problems may be reduced to dual integral equations. The general treatment of mixed boundary value problems by dual integral equations is given by Sneddon¹⁾.

At first we describe an electrostatic problem of disc electrodes as a general case. The solution may be easily interpreted as that of an appropriate steady current field problem. After the general treatment, two important problems are discussed as special cases.

2. Statement of the Problem

As shown in Fig. 1, we consider an infinite plate of thickness $2t$ and of dielectric constant ϵ_1 in uniform space of dielectric constant ϵ_2 . We use the cylindrical coordinates of Fig. 1. Two identical conducting discs of radius 1 are mounted coaxially as electrodes on this plate. The electrodes are maintained at prescribed potential V_0 and $-V_0$ respectively. We attempt to find the distribution of potential in the whole space and compute the capacity between two electrodes.

If we denote the potential for $z \geq t$, $t \geq z \geq -t$ and $-t \geq z$ by V^+ , V and V^-

* Department of Electrical Engineering II.

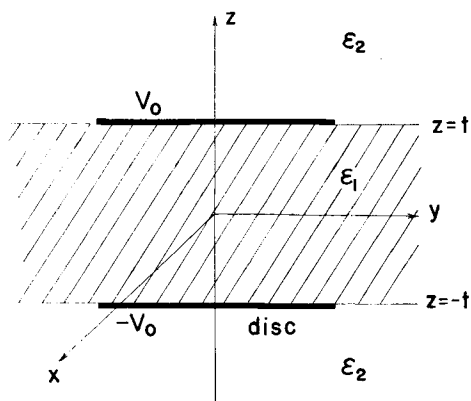

Fig. 1. Setup of two disc electrodes for an electrostatic problem. Two disc electrodes of radius 1 are mounted coaxially on an infinite plate. For a steady current problem, ϵ_i should be exchanged into σ_i .

respectively, the boundary conditions to be satisfied are:

$$V^\pm = V, \quad z = \pm t \quad (1)$$

$$V^\pm = \pm V_0, \quad z = \pm t, \quad 0 \leq \rho < 1 \quad (2)$$

$$\epsilon_2 \frac{\partial V^\pm}{\partial Z} = \epsilon_1 \frac{\partial V}{\partial z}, \quad z = \pm t, \quad \rho > 1. \quad (3)$$

3. Integral Equations

In view of symmetric setup of the problem, the potential may be described in the following integral forms:

$$\left. \begin{aligned} V^+ &= V_0 \int_0^\infty u^{-1} \{e^{(z-t)u} - e^{-(z+t)u}\} L(u) J_0(\rho u) du, & z \geq t \\ V &= V_0 \int_0^\infty u^{-1} \{e^{(z-t)u} - e^{-(z+t)u}\} L(u) J_0(\rho u) du, & -t \leq z \leq t \\ V^- &= V_0 \int_0^\infty u^{-1} \{e^{(z-t)u} - e^{-(z+t)u}\} L(u) J_0(\rho u) du, & z \leq -t \end{aligned} \right\}. \quad (4)$$

These functions have the property on the plane $z=t$

$$V^+ = V = V_0 \int_0^\infty u^{-1} (1 - e^{-2tu}) L(u) J_0(\rho u) du$$

and $z=-t$

$$V^- = V = -V_0 \int_0^\infty u^{-1} (1 - e^{-2tu}) L(u) J_0(\rho u) du.$$

Therefore condition (1) is satisfied for any function $L(u)$. The function $L(u)$ should be determined so that conditions (2) and (3) may be satisfied. Substitution of Eqs. (4) into Eq. (2) gives

$$\int_0^\infty u^{-1}(1-e^{-2tu})L(u)J_0(\rho u)du = 1, \quad 0 \leq \rho < 1. \quad (5)$$

Since

$$\begin{aligned} \frac{\partial V^\pm}{\partial z} \Big|_{z=\pm t} &= -V_0 \int_0^\infty (1-e^{-2tu})L(u)J_0(\rho u)du \\ \frac{\partial V}{\partial z} \Big|_{z=\pm t} &= V_0 \int_0^\infty (1+e^{-2tu})L(u)J_0(\rho u)du, \end{aligned}$$

condition (3) is expressed as

$$\int_0^\infty (1+\kappa e^{-2tu})L(u)J_0(\rho u)du = 0, \quad \rho > 1, \quad (6)$$

where

$$\kappa = \frac{\varepsilon_1 - \varepsilon_2}{\varepsilon_1 + \varepsilon_2}. \quad (7)$$

If we write

$$M(u) = (1+\kappa e^{-2tu})L(u) \quad (8)$$

and

$$k(u) = -\frac{(\kappa+1)e^{-2tu}}{1+\kappa e^{-2tu}}, \quad (9)$$

we have $\{1-\exp(-2tu)\}L(u) = \{1+k(u)\}M(u)$ and Eqs. (5) and (6) lead to dual integral equations,

$$\int_0^\infty u^{-1}\{1+k(u)\}M(u)J_0(\rho u)du = 1, \quad 0 \leq \rho < 1 \quad (10)$$

$$\int_0^\infty M(u)J_0(\rho u)du = 0, \quad \rho > 1. \quad (11)$$

According to Sneddon²⁾, the dual integral equations may be reduced to a more convenient form. If we write

$$M(u) = \frac{u}{\sqrt{\pi}} \int_0^1 v \cos uv h_1(v) dv, \quad (12)$$

the dual integral equations (10) and (11) are reduced to a Fredholm integral equation of the second kind

$$h_1(x) + \int_0^1 h_1(u) K(x, u) du = \frac{2}{x\sqrt{\pi}}, \quad (13)$$

where

$$K(x, u) = \frac{u}{x\sqrt{2\pi}} \{K_c(|x-u|) + K_c(x+u)\} \quad (14)$$

and $K_c(\xi)$ denotes the Fourier cosine transform of $k(u)$:

$$K_c(\xi) = \sqrt{\frac{2}{\pi}} \int_0^\infty k(u) \cos \xi u \, du. \quad (15)$$

If we define $f(x)$ by

$$f(x) = \frac{\sqrt{\pi}}{2} x h_1(x), \quad (16)$$

we have from Eq. (13)

$$f(x) + \frac{1}{\sqrt{2\pi}} \int_0^1 f(u) \{K_c(|x-u|) + K_c(x+u)\} \, du = 1. \quad (17)$$

Substitution of Eq. (16) into Eq. (12) gives

$$M(u) = \frac{2}{\pi} u \int_0^1 f(v) \cos uv \, dv. \quad (18)$$

Taking both sides of an electrode into consideration, the charge density $\sigma(\rho)$ on the upper electrode is expressed by

$$\begin{aligned} \sigma(\rho) &= -\varepsilon_2 \frac{\partial V^+}{\partial z} \Big|_{z=t} + \varepsilon_1 \frac{\partial V}{\partial z} \Big|_{z=t} \\ &= (\varepsilon_1 + \varepsilon_2) V_0 \int_0^\infty M(u) J_0(\rho u) \, du \\ &= \frac{2}{\pi} (\varepsilon_1 + \varepsilon_2) V_0 \int_0^1 f(v) \, dv \int_0^\infty u J_0(\rho u) \cos uv \, du. \end{aligned} \quad (19)$$

If we denote the total electric charge on the upper electrode by Q , we have

$$\begin{aligned} Q &= \int_0^1 2\pi \rho \sigma(\rho) \, d\rho \\ &= 4(\varepsilon_1 + \varepsilon_2) V_0 \int_0^1 f(v) \, dv, \end{aligned} \quad (20)$$

where use is made of formulas such that

$$\begin{aligned} \int_0^1 \rho J_0(\rho u) \, d\rho &= \frac{1}{u} J_1(u) \\ \int_0^1 J_1(u) \cos uv \, du &= 1, \quad v < 1. \end{aligned}$$

The capacity C between the two electrodes is given by

$$C = \frac{Q}{2V_0} = 2(\epsilon_1 + \epsilon_2) \int_0^1 f(v) dv. \tag{21}$$

The integral equation for $M(u)/u$ may be derived from the integral equation (17). Multiplying both sides of Eq. (17) by $(2/\pi) \cos ux$ and integrating from 0 to 1, we have

$$\frac{M(u)}{u} = \frac{2}{\pi} \frac{\sin u}{u} - \frac{1}{\pi} \int_0^\infty k(\lambda) \left\{ \frac{\sin(u+\lambda)}{u+\lambda} + \frac{\sin(u-\lambda)}{u-\lambda} \right\} \frac{M(\lambda)}{\lambda} d\lambda. \tag{22}$$

So far we have considered an electrostatic problem but we can treat an appropriate steady current field problem in the same way by exchanging ϵ_i into σ_i . In this case we can compute the inverse of the resistance between the two electrodes by Eq. (21).

4. Special Cases

We now show that two well-known disc electrode problems may be treated as special cases.

1) $\kappa=0$. We consider the case in which the whole space is filled with uniform medium of dielectric constant ϵ ($=\epsilon_1=\epsilon_2$). This problem has been discussed as that of a plate condenser by many authors. From Eqs. (22) and (9) with $\kappa=0$, we have

$$y(u) = \frac{2}{\pi} \frac{\sin u}{u} + \frac{1}{\pi} \int_0^\infty e^{-2t\lambda} \left\{ \frac{\sin(u+\lambda)}{u+\lambda} + \frac{\sin(u-\lambda)}{u-\lambda} \right\} y(\lambda) d\lambda, \tag{23}$$

where $y(u) = M(u)/u$. This is identical with the result by Nicholson³⁾. Substitution of Eq. (9) with $\kappa=0$ into Eq. (15) gives

$$K_c(\xi) = -\sqrt{\frac{2}{\pi}} \frac{2t}{\xi^2 + 4t^2}. \tag{24}$$

From Eqs. (24) and (17), we have

$$f(x) - \frac{1}{\pi} \int_{-1}^1 \frac{2t}{(x-u)^2 + 4t^2} f(u) du = 1. \tag{25}$$

This is identical with the result by Love⁴⁾.

2) $\kappa=1$. We now consider the steady current problem. We assume that the plate of finite conductivity σ_1 is bounded by vacuum at $z = \pm t$. Thus we have $\sigma_2=0$.

Kiyono and Tsuda⁵⁾ pointed out that the well-known solution of Riemann to this problem was incorrect because it led to a physical contradiction.

Substitution of $\kappa=1$ into Eq. (9) gives

$$k(u) = -\frac{e^{-tu}}{\cosh tu}. \quad (26)$$

If we write

$$B(u) = \frac{1}{\cosh tu} \cdot \frac{M(u)}{u}, \quad (27)$$

we have from Eqs. (4) and (8)

$$V = V_0 \int_0^\infty B(u) \sinh zu J_0(\rho u) du, \quad |z| \leq t. \quad (28)$$

From Eqs. (22) and (27), we have

$$B(u) = \frac{2}{\pi} \frac{\sin u}{u \cosh tu} + \frac{1}{\pi} \int_0^\infty \frac{e^{-t\lambda}}{\cosh tu} \left\{ \frac{\sin(u+\lambda)}{u+\lambda} + \frac{\sin(u-\lambda)}{u-\lambda} \right\} B(\lambda) d\lambda. \quad (29)$$

This is identical with the result established by Kiyono and Tsuda. Eq. (29) may be solved numerically with the aid of the Laguerre-Gauss quadrature formula. The numerical computation of the resistance between the two electrodes and the difference between Riemann's solution are discussed in 6).

References

- 1) I.N. Sneddon: "Mixed Boundary Value Problems in Potential Theory" North-Holland Publ. Co. (1966).
- 2) Ibid. pp. 106-113.
- 3) J.W. Nicholson: The Electrification of Two Parallel Circular Discs, Phil. Trans. Roy. Soc. London A, **224**, pp. 303-369 (1924).
- 4) E.R. Love: The Electrostatic Field of Two Equal Circular Co-axial Conducting Disks, Quart. J. Mech. and Appl. Math., **2**, pp. 428-451 (1949).
- 5) T. Kiyono and T. Tsuda: Some Contributions to the Theory of Electrostatic Field, THIS MEMOIRS, Vol. XXX, Part 3 (Sept. 1968) pp. 315-326.
- 6) T. Kiyono and M. Shimasaki: On the Resistance between the Two Disc Electrodes Applied to an Infinite Plate Conductor, THIS MEMOIRS, Vol. XXX, Part 4 (Oct. 1968) pp. 463-479.