



TITLE:

Effect of Humidity of Atmosphere on the Electrostatic Separation of Coal

AUTHOR(S):

MUKAI, Shigeru; WAKAMATSU, Takahide;
ISHIKAWA, Tsuneo

CITATION:

MUKAI, Shigeru ...[et al]. Effect of Humidity of Atmosphere on the Electrostatic Separation of Coal. Memoirs of the Faculty of Engineering, Kyoto University 1966, 28(1): 66-80

ISSUE DATE:

1966-03-26

URL:

<http://hdl.handle.net/2433/280650>

RIGHT:

Effect of Humidity of Atmosphere on the Electrostatic Separation of Coal

By

Shigeru MUKAI*, Takahide WAKAMATSU* and Tsuneo ISHIKAWA*

(Received September 30, 1965)

In order to recover the coal concentrate of low ash content, the electrostatic separation of coal was investigated.

The separations with and without heating of feed were performed. It was ascertained that the separation without heating in the room temperature and the normal humidity resulted in an excellent recovery, about 98%, to obtain very low ash coal. From the results it was recognized that a suitable humidity was necessary for the electrostatic separation of coal.

The effect of humidity on the electrostatic separation of coal was then studied through the measurements of electric discharge between electrodes, the adsorbed moisture on coal, and the electric charge on coal particles in terms of humidity. From these results, it was made clear that the electrostatic separation was excellent in 40~80% relative humidity of atmosphere.

1. Introduction

The separation in the electrostatic field is mainly governed by the surface electric conductivity of the material. The surface electric conductivity is much affected by the adsorbed moisture. The adsorbed moisture on surface is mainly affected by the atmospheric humidity. At high humidity, there is no difference in the conductivity between the conductive material and the insulator, and thus they behave similarly each other in the electrostatic field. Accordingly, it is an ordinary procedure in the electrostatic separation that the feed to the separator is perfectly dried.

However, the authors recognized in the electrostatic separation of coal that the low ash coal is recovered efficiently in room temperature and normal atmospheric humidity without drying of the feed by heating. Therefore, it is important for a reasonable application of the electrostatic separation to clarify the effect of the humidity of atmosphere and the drying condition of feed on the separation of coal.

* Department of Mineral Science and Technology.

In this paper, the effect of humidity on the electrostatic separation of coal was investigated, in order to recover the coal concentrate of low ash content.

2. Samples and Separator

The coals from the Akabira mine in Hokkaido, Japan, were used in this study. The ash content of coal tested was 6.5% on the average.

The apparatus of the electrostatic separation used in this experiment was the Huff type separator. In order to generate the corona discharge field, a needle-shaped electrode combined with a plate electrode is installed as the high tension electrode. The principal part of the apparatus is shown in Fig. 1.

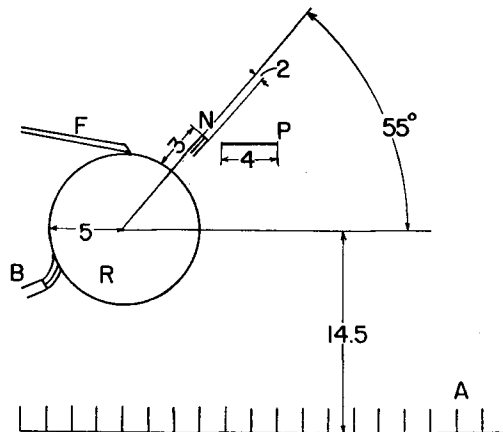

Fig. 1. Principal parts of separator
 A: Products acceptor B: Brush F: Feeder N:
 Needle electrode P: Plate electrode R:
 Grounded roller (Given numerals in cm)

The heaters for drying of sample were equipped under the feeder and inside the grounded roller of the apparatus, so that the temperature of feed can be raised from the room temperature to 100°C.

3. Effect of Heating on the Electrostatic Separation

The separation test was first performed after coal particles were heated at 100°C for one hour on the feeder of the separator. The high tension electrode was negatively charged. One of the experimental results is shown in Fig. 2.

In this Figure, the weight % and the ash content of the products distributed by the separation are represented as a function of the repelling distance,

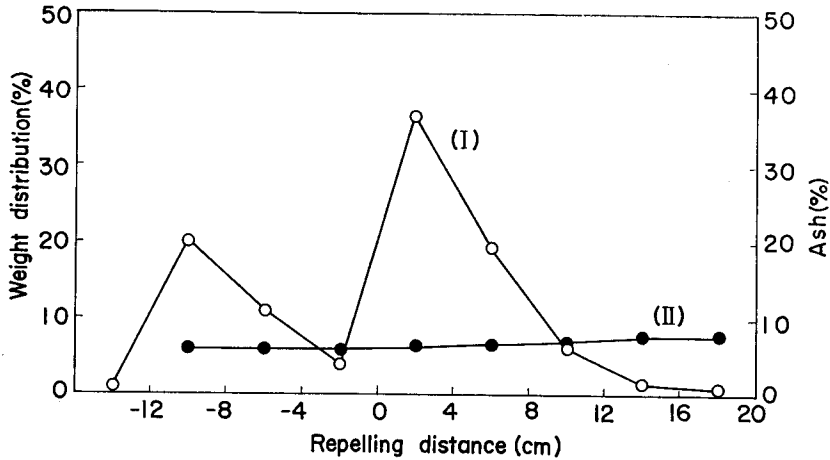

Fig. 2. A result of separation with heating of feed
(I) Weight distribution (II) Ash content

and the base point of the distributed position is taken directly below the grounded roller surface, thus the direction repelled from the roller being taken positively while the direction attracted negatively.

As can be seen in Fig. 2, the particles attracted to the grounded roller are relatively in small amount, despite the increased accumulation of particles fallen freely from the roller. Furthermore, the differences in ash content of products depending on the repelling distance are not perceptible. Accordingly, the separation is not satisfactory.

The separation test without heating of the feed was secondarily performed in the room temperature and the normal humidity of atmosphere. The relations between the weight % or the ash content of products and the repelling distance are illustrated in Fig. 3.

It is clear from the results of Fig. 3 that the particles attracted to the grounded roller are increased in recovery in the testing without heating, and that the ash contents of these particles are remarkably low while the ash contents of particles repelled from the roller are very high.

The efficiency of this separations was considered on the basis of the float-and-sink analysis for the feed coal and the concentrate coal, since generally the specific gravity of coal is directly proportional to the ash content.

The washability curves for the feed coal are shown in Fig. 4.

Considering the products obtained in the range $-4 \sim -16$ cm of repelling distance as the concentrate coal, its washability curves are as shown in Fig. 5.

It is recognized from the results of Fig. 5 that the products of $-4 \sim -16$ cm

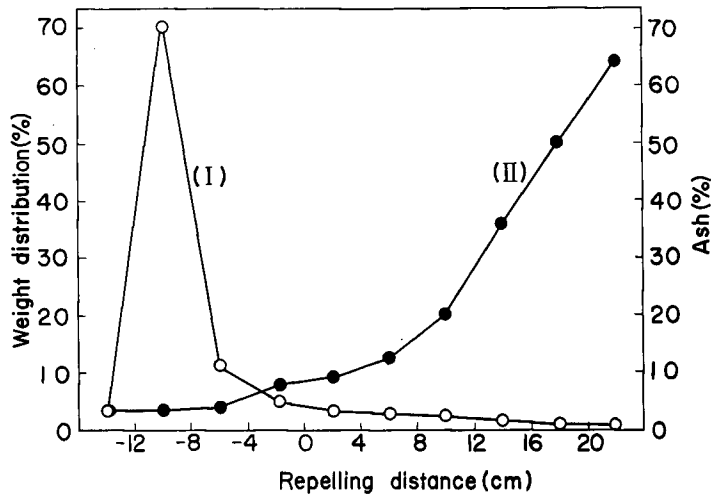

Fig. 3. A result of separation without heating of feed
(I) Weight distribution (II) Ash content

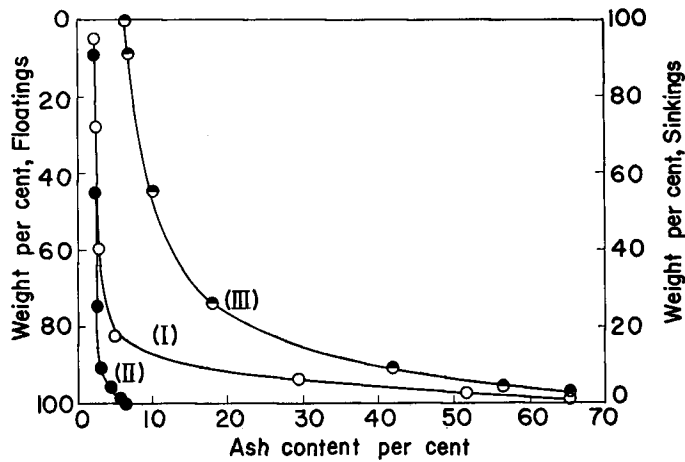

Fig. 4. Washability curve for feed
(I) Observed curve (II) Floatings curve (III) Sinkings curve

are less than 3% ash content. And it is clear from the results obtained in Fig. 3, 4, and 5 that the recovery of coal which has less than 2.5% ash content is estimated as a 98% recovery in the concentrate.

This concentrate was observed microscopically as shown in Fig. 6 and the great part of it was identified as a bright coal.

It was ascertained from the above results that heating of the feed had a bad effect on the separation and that the separation without heating in the

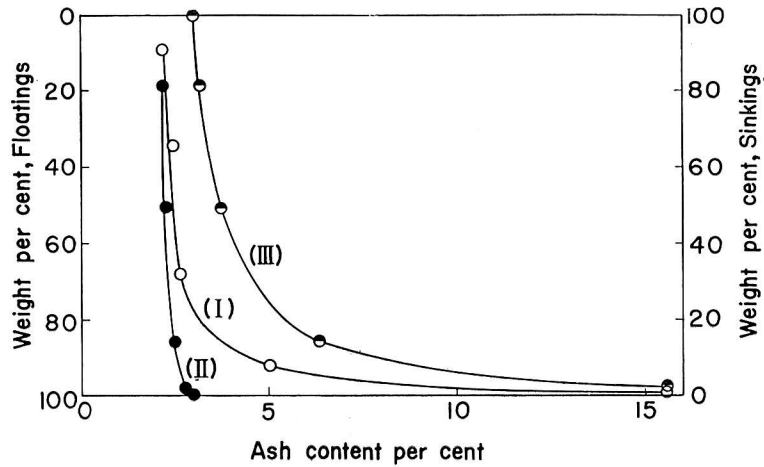

Fig. 5. Washability curve for concentrate
 (I) Observed curve (II) Floatings curve (III) Sinkings curve



Fig. 6. Microphotograph of coal concentrate

room temperature and normal humidity was resulted in an excellent recovery to obtain the low ash coal, namely bright coal.

4. Effect of Humidity of Atmosphere on the Separation

The electric charge on coal particles in an electric field depends upon the electric discharge between electrodes, the dielectric constant and the electric conductivity of coal particles.

The electric discharge between electrodes of separator is affected by the humidity of atmosphere. The adsorbed moisture of coal particles also relates closely to the humidity. Accordingly, the effect of humidity on the electrostatic separation was investigated.

4-1. Electric discharge between electrodes

Two electrodes, a needle-shaped electrode and a plate electrode confronting each other, were set in a glass vessel whose inside was kept at a constant humidity, as illustrated in Fig. 7.

In order to keep constant humidity in the glass vessel, aqueous solutions saturated by some kinds of electrolytes were used. The saturated solutions of the various electrolytes and their relative humidity at 20°C are represented in Table 1.

The discharge currents between electrodes in terms of the applied voltage

were measured varying the relative humidity of the atmosphere. The measurement was performed after the humidity in the vessel became constant. The results of the measurement are as shown in Fig. 8.

It is noticed in Fig. 8 that the discharge current increases with increasing of applied voltage at constant humidity and also that the discharge current increases with increasing of humidity at a constant applied voltage. It can be seen that the electric discharge between electrodes close relates to the humidity of atmosphere. The electric discharge become vigorous with increasing of the humidity. Accordingly, the coal particles placed on the positive electrode are exposed to the collision of electrons when the electric discharge occurs.

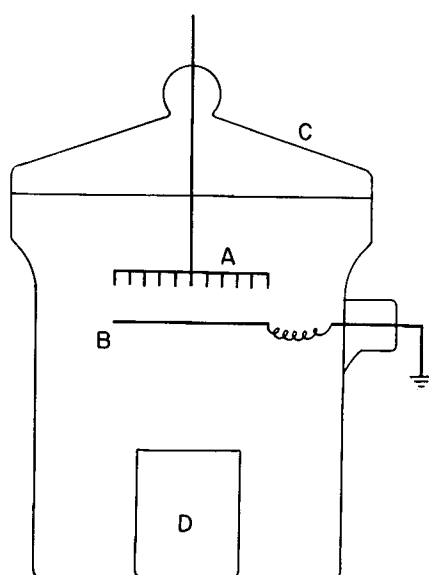

Fig. 7. A glass vessel for measuring discharge current between electrodes at constant humidity

A: Needle electrode B: Plate electrode
C: Glass vessel D: Aqueous solution saturated by electrolyte

Table I Various electrolytes and their relative humidity (at 20°C)

Solute	Water vapour pressure	Relative humidity	Solute	Water vapour pressure	Relative humidity
ZnCl ₂	1.74	10	Ca(NO ₃) ₂ ·4H ₂ O	9.54	55
LiCl	2.60	15	Mg(CH ₃ COO) ₂	11.3	65
CH ₃ COOK	3.47	20	CH ₃ COONa	13.2	76
CaCl ₂	5.61	32	KBr	14.6	84
Zn(NO ₃) ₂ ·6H ₂ O	7.29	42	Na ₂ SO ₄ ·10H ₂ O	16.1	92

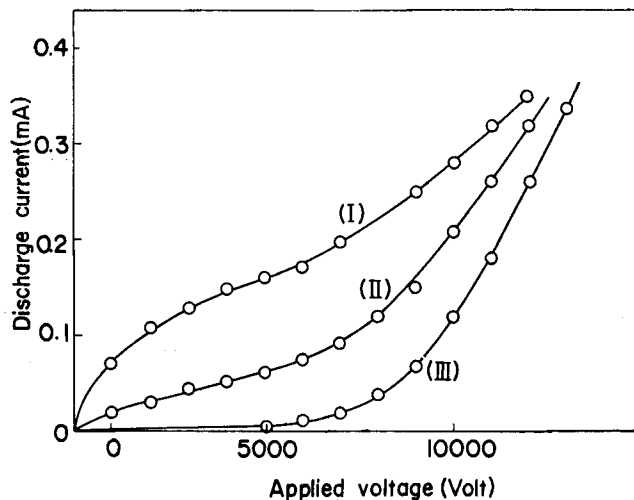

Fig. 8. Discharge current between electrodes
 (I) 100% relative humidity (II) 70% relative humidity (III) 0% relative humidity

From the above reason, it is considered that the humidity of atmosphere influences remarkably on the electrostatic separation of coal.

4-2. Adsorbed moisture in relation to humidity

Two coal samples identified as the bright coal and the dull coal were prepared from the same one used as a feed for the electrostatic separation. The bright coal tested has 3% ash content, while the dull coal 13% ash content. These samples were microscopically observed as shown in Fig. 9 and Fig. 10 to confirm as a durain and a vitrain.

And the adsorbed moisture was measured as a function of the humidity of atmosphere.

After the 65~100 mesh samples of the bright coal or the dull coal were kept sufficiently at a constant humidity, they were put in a desiccator with phosphorous pentoxide as drying reagent for two days. Then the differences in weight between the former treatment and the later were measured. These differences in weight are regarded as the adsorbed moisture on the surface of coal particles.

The results of the measurement are as shown in Fig. 11.

It is recognized from the results shown in Fig. 11 that the amount of adsorbed moisture increases with increasing of the humidity. Comparing the adsorbed moisture on the bright coal with that on the dull coal, it can be seen that the adsorbed moisture on the dull coal is generally much more in



Fig. 9. Microphotograph of high ash coal, durain

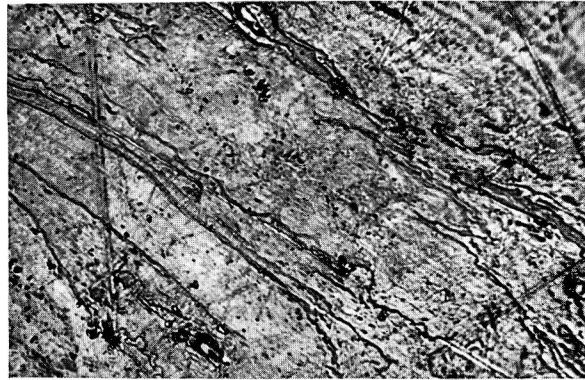

Fig. 10. Microphotograph of low ash coal, vitrain

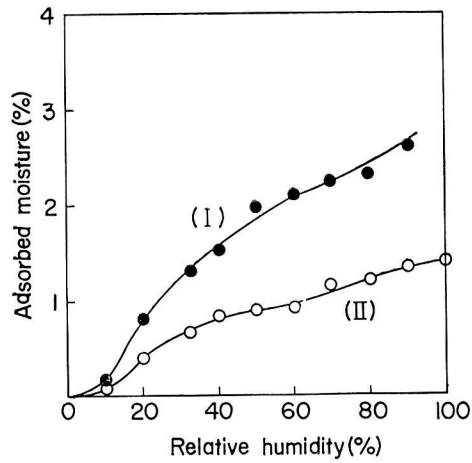

Fig. 11. Relation between relative humidity and adsorbed moisture
(I) Dull coal (II) Bright coal

amount than that on bright coal. This fact shows that the dull coal has much more affinity to moisture. The adsorbed moisture gives itself good surface conductivity.

If the particles become conductive, the charge of the particles acquired by the collision of the electrons is neutralized immediately by the opposite charge of the grounded electrode. Accordingly, the charge of the particles is governed by the charge of the grounded electrode. In this case, the charge of the particles acts as a repelling force to the particles. Thus the dull coal particles are repelled from the grounded roller in the electrostatic separation.

On the other hand, the bright coal particles are poor conductors because of the small quantity of the adsorbed moisture.

Accordingly the charge of the bright coal particles, acquired from the grounded electrode is imperceptible. The charge of the bright coal is mainly due to the collision of electrons. Consequently, the bright coal are attracted to the roller.

Thus, it is can be seen that the difference of adsorbed moisture between the bright coal and the dull coal which depends on the humidity of atmosphere causes the electric charge difference among coal particles. So, it is clear from a view point of the adsorbed moisture that the humidity of atmosphere affects the electrostatic separation.

4-3. Effect of humidity on the critical electric field intensity

Two plain electrodes paralleled each other were set in a glass vessel with a saturated solution of some kinds of electrolytes for keeping a constant humidity as shown in Fig. 12.

After the 65~100 mesh coal particles were placed on the grounded electrode plate for two days, the applied voltage between the electrode was gradually increased in order to obtain the critical electric field intensity at which coal particles repel from the grounded electrode plate. The experimental results are shown in Fig. 13.

Fig. 13 shows that the critical electric field intensity varies with the variation of humidity, namely it decreases with increasing the humidity. Although, either in damp air of more than 90% humidity or drying of less than 10% the critical intensity value of the bright coal and the dull coal become nearly the same value, the dull coal is generally repelled from the electrode plate at lower intensity than the bright coal.

From the above results, it is recognized that the humidity of atmosphere remarkably affects the electrostatic separation of coal and that the extremely

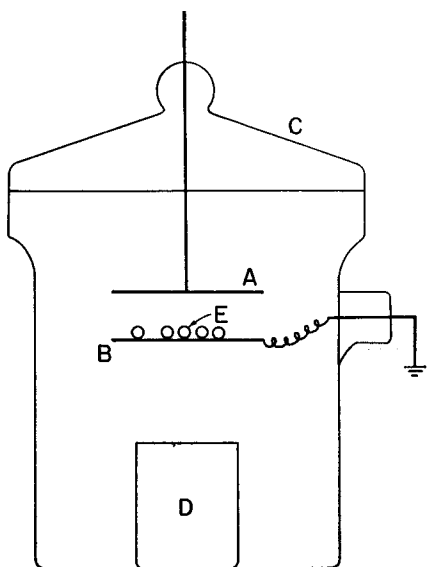

Fig. 12 A glass vessel for determining the critical electric field intensity
 A: Plate electrode B: Grounded plate electrode C: Glass vessel D: Aqueous solution saturated by electrolyte E: Coal particles

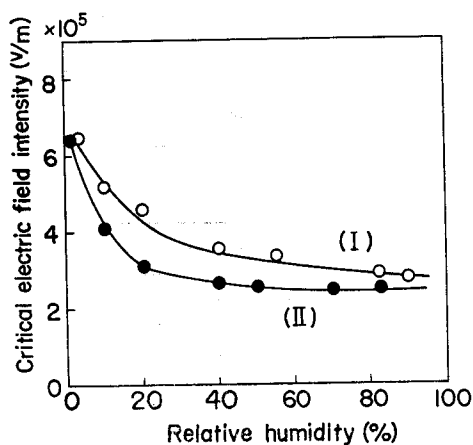

Fig. 13. Relation between relative humidity and critical electric field intensity
 (I) Bright coal (II) Dull coal

low or high humidity is not suitable for the separation of the bright coal and the dull coal.

5. Electric Charge on Coal Particles

It was clarified in the former sections that the heating and the humidity of atmosphere are most important factors on the electrostatic separation. Furthermore, the electric charge on coal particles put in various humidity of atmosphere was investigated.

5-1. Electric charge on coal particles in relation to humidity

Electric charge was measured by means of the condenser. The insulated metal vessel in which the coal particles from the separator accumulate, the condenser, and the vacuum tube voltmeter were arranged as illustrated in Fig. 14. The condenser capacity is $0.01\mu F$.

The authors have ever adopted the method by using a ballistic galvanometer,¹⁾ as previously reported, in order to measure the electric charge on coal particles. Some comparisons between two methods were performed and any difference in the experimental value of the electric charge between them was not perceptible as represented in Table 2.

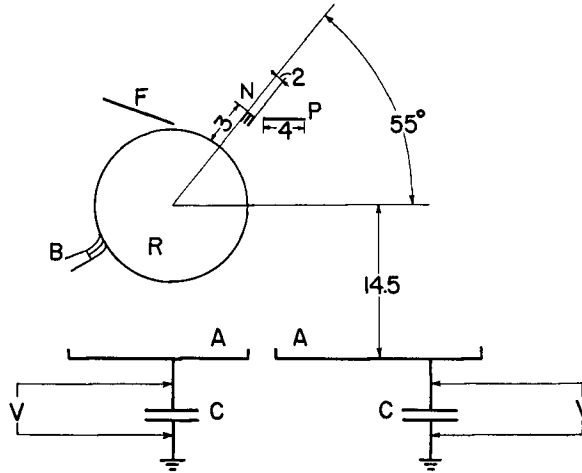

Fig. 14. Principal parts for measuring electric charge on coal particles

F: Feeder N: Needle electrode P: Plate electrode
 R: Grounded roller A: Insulated product acceptor
 C: Condenser V: Vacuum tube voltmeter

Table II Comparison of the procedure employed in this experiments with that by ballistic galvanometer

Coal type	Procedure of electric charge measurement	Applied voltage		
		10 KV	15 KV	20 KV
Bright coal	Employed in this experiments	-3.2×10^{-9} coul/g	-9.2×10^{-9} coul/g	-11×10^{-9} coul/g
	By ballistic galvanometer	-3.4×10^{-9}	-9.1×10^{-9}	-12×10^{-9}
Dull coal	Employed in this experiments	2.1×10^{-9}	8.8×10^{-9}	9.6×10^{-9}
	By ballistic galvanometer	2.3×10^{-9}	8.8×10^{-9}	9.6×10^{-9}
Size 28~35 mesh, Relative humidity 75%				

The particles of the bright coal or the dull coal were placed in an atmosphere of constant humidity for two days, then these particles were fed to the Huff separator and the electric charge of the products was measured. From the experimental results, the relation between the electric charge of the coal particles and the humidity of atmosphere at which the particles were placed before separating was investigated. The results are shown in Fig. 15.

The sign of the charge of the bright coal and that of the dull coal are

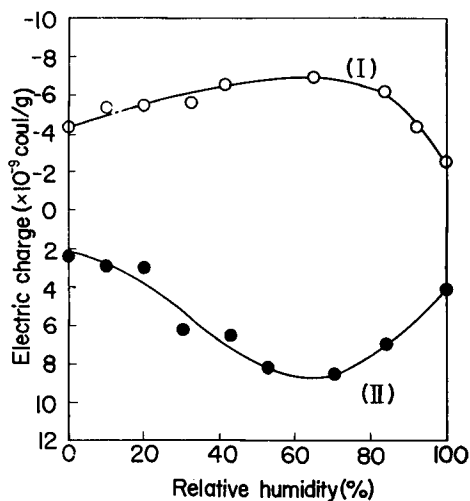

Fig. 15 Relation between conditioning humidity and electric charge on coal particles
(I) Bright coal (II) Dull coal

different from each other. As these experiments were performed by using the negative high tension electrode, the dull coal has the positive charge, while the bright coal has the negative charge. The charge amount of the coal particles varies with varying of the humidity of atmosphere. The electric charge on coal particles varies in parabolic curve with the variation of the humidity, indicating the maximum amount of charge at about 60% in the relative humidity. In the extremely low or high value of the humidity, the difference of the electric charge on the dull coal and the bright coal is small in amount. The humidity of about 60% shows the largest difference in the electric charge between the bright coal and the dull coal. This humidity seems to be the most suitable for separating the bright coal and the dull coal.

Discussing the above results with those of the critical intensity mentioned in the former section, it is clear that the favourable condition for the electrostatic separation of coal is the 40~80% relative humidity of the atmosphere.

5-2. Electric charge on coal particles in relation to heating temperature

The relation between the electric charge on coal particles, the dull coal or the bright coal, and the heating temperature of feed was investigated. The particles of the bright coal or the dull coal were heated at various temperature for one hour. Then these particles were fed to the Huff separator to measure the electric charge of the product particles. The electric charge

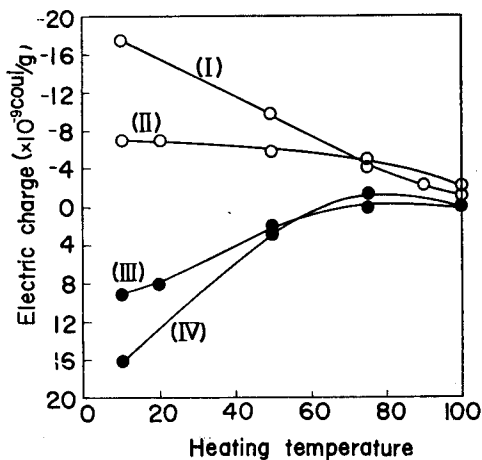

Fig. 16. Relation between heating temperature and electric charge on coal particles
 (I) Bright coal, 28~35 mesh (II) Bright coal, 10~14 mesh (III) Dull coal, 10~14 mesh (IV) Dull coal, 28~35 mesh

was measured by the same method as shown in Fig. 14. The results of the experiment are shown in Fig. 16. As can be seen from Fig. 16, the electric charge of the dull coal and the bright coal varies remarkably with the variation of the heating temperature. The electric charge of the coal particles decreases with increase of the heating temperature, and the difference in the electric charge between the bright coal and the dull coal is not perceptible at 100°C. The smaller the size of coal particles, the greater is the effect of the heating temperature on the electrical charging.

The bad effect of heating on the separation of the bright coal and the dull coal should be based on the fact that there is no difference in the electrical charge between the bright coal and the dull coal.

6. Conclusion

In order to recover the coal concentrate of low ash content, the electrostatic separation of coal were studied. The results of this study are summarized as follows:

(1) The electrostatic separation was performed after coal particles were heated at 100°C for one hour. From the experimental result, the differences in ash content of the products of the separation are not perceptible. Accordingly it is considered that separation of the low ash coal from the high ash coal is not successful when the coal feed is heated.

(2) The separation without heating of the coal particles was secondarily performed in the room temperature and the normal humidity of atmosphere. As the result, it was ascertained that the separation without heating in the room temperature and the normal humidity resulted in an excellent recovery, i.e. about 98%, to obtain the very low ash coal, less than 2.5% ash content.

(3) The concentrate obtained by the separation was observed microscopically. And the great part of the concentrate was identified as a bright coal.

(4) The electric discharge between the needle-shaped electrode and the plate electrode was investigated. This electric discharge between both electrodes relates closely with the humidity of atmosphere and becomes vigorous with increasing the humidity. Accordingly, the coal particles placed on the positive electrode are exposed to a collision of electrons. From this fact, it is thought that the humidity of atmosphere remarkably influences the electrostatic separation.

(5) The adsorbed moisture on the bright coal and the dull coal was measured as a function of the humidity of atmosphere. Comparing the adsorbed moisture on the bright coal with that on the dull coal, it can be seen that the adsorbed moisture on the dull coal is much in amount than that of the bright coal. The dull coal absorbed moisture become more conductive than the bright coal.

The electric charge of the dull coal acquired by the collision of electrons is neutralized immediately by the opposite charge of the grounded electrode. The charge of the dull coal is governed by the charge of the grounded electrode, while the charge of the bright coal is mainly due to the collision of electrons. As the result, it can be considered that the dull coal particles are repelled from the grounded roller, while the bright coal particles are attracted to the roller.

(6) The relation between the critical electric field intensity at which coal particles repel from an electrode and the humidity of atmosphere was determined. The particles of the high ash coal repel at lower electric intensity than those of the low ash content. However, both of them behave similarly in the extremely low or high humidity.

(7) The coal particles were placed in various humidity of atmosphere and then separated by the electrostatic separator. The electric charge of these coal particles was measured by means of the condenser.

The charge amount of the coal particles varies with varying of the humidity in which the coal particles were placed. The electric charge of

low ash coal is opposite in its sign to that of the high ash coal. The electric charge on coal particles varies in parabolic curve with the variation of humidity, indicating the maximum amount of charge at about 60% in relative humidity. In the extremely low or high value of the humidity, the difference of the electric charge on the bright coal and dull coal is small in amount. The humidity of about 60% shows the largest difference in the electric charge between the bright coal and the dull coal. This humidity seems to be the most suitable for separating the bright coal and the dull coal.

(8) The relation between the electric charge on coal particles and the heating temperature of feed was discussed. The electric charge of coal particles decreases with decreasing of the heating temperature. There is no difference in the electric charge between the high ash coal and the low ash coal at temperature 100°C. Consequently, it is considered that the heating of feed gives a bad effect for the electrostatic separation of the low ash coal from the high ash coal.

From above results, it was clarified that the electrostatic separation was excellent in the 40~80% relative humidity of atmosphere.

Reference

- 1) S. Mukai, T. Wakamatsu, and Y. Shida; "Study on the Electrostatic Concentration of Low Ash Coal in Corona Discharge Field", the Memoirs of the Faculty of Engineering, Kyoto University, vol. 25, Part 3, July 1963, pp. 334~358.