



TITLE:

# Studies on the Electrolysis of Sodium Sulfate Solution

AUTHOR(S):

OKADA, Shinzo; YOSHIZAWA, Shiro; HINE, Fumio;  
HARA, Hiromichi; ANDO, Satoshi; KIMURA, Isao

---

CITATION:

OKADA, Shinzo ...[et al]. Studies on the Electrolysis of Sodium Sulfate Solution. Memoirs of the Faculty of Engineering, Kyoto University 1962, 24(1): 112-121

ISSUE DATE:

1962-03-31

URL:

<http://hdl.handle.net/2433/280515>

RIGHT:

Studies on the Electrolysis of Sodium Sulfate Solution<sup>†</sup>

By

Shinzo OKADA\*, Shiro YOSHIZAWA\*, Fumio HINE\*,  
Hiromichi HARA\*\*, Satoshi ANDO\*\* and Isao KIMURA\*\*

(Received October 7, 1961)

The electrolysis of sodium sulfate solution by the 1500 amp. vertical mercury cell was investigated. Lead alloy containing 2% Ag and 1% Te was selected as the anode, and fine porous rubber sheet or blue asbestos cloth were used as the diaphragm. The concentrations of sulfuric acid and caustic soda obtained were 200-250 g/l H<sub>2</sub>SO<sub>4</sub> and 30-40% NaOH, respectively, under the condition of 30 amp/dm<sup>2</sup> of current density by continuous operation. The terminal voltage was less than 5.0 volts and the current efficiency and the consumption of the anode were 90% and 2-3 mg/AH, respectively.

**I. Introduction**

In spite of the fact that the electrolysis of sodium sulfate solution has been studied by some authors previously, most of those studies were just laboratory measurements with little consideration of economic conditions.

This paper emphasizes the economic point of view as follows:

1. Anti-corrosive anode material and its utilization.
2. The choice of a suitable diaphragm for electrolysis.
3. Study of the most desirable process for electrolysis.
4. Cell operation under conditions of high current densities and low terminal voltages, similar to the chlor-caustic soda industry.

**II. Studies on the Anode Material**

Platinum, platinum-iridium alloy, and also pure lead have been used as anodes of electrolysis of sulfate solution in previous work<sup>1)</sup>. According to the P. B. Fiat Final Report, I. G. in Germany used Ag (10%)-Pb alloy during World War II<sup>2)</sup>. While this is very expensive, it is an excellent material against corrosion.

A new alloy, consisting of Ag-Pb and a third metal, has been investigated by the authors. This alloy is the eutectic and is more economical and is also a good anti-corrosive material<sup>3)</sup>.

† Presented at The Indianapolis Meeting of The Electrochemical Society, May 3, 1961.

\* Department of Industrial Chemistry

\*\* Kanegafuchi Spinning Co.

The test of corrosion rate was carried out in a small electrolyser of which the total current was 10 amp. The cathode and the diaphragm of this cell were made of mercury and polyvinyl chloride sponge, respectively, and the concentration of electrolyte was 350 g/l of sodium sulfate.

Table 1. Consumption of anode material of various Ag(2%)-Te(x%)-Pb alloys.

content of Te x (%)	consumption of anode material (mg/AH)
1	1.27
5	1.57
10	0.28
15	0.28
18	3.51*
20	8.08*

\* weight increased.

Ag-Te-Pb alloy was selected from among many types of alloys examined by the preliminary experiment shown above. The results of the anode consumption of the Ag-Te-Pb alloy are presented in Table 1.

Three kinds of lead alloy, consisting of Ag (2%)-Te (1%)-Pb, Ag (2%)-Te (10%)-Pb, and Ag (2%)-Te (15%)-Pb, were selected for detailed study in a large scale electrolyser with consideration of both the technical and economic points of view. Ag (10%)-Pb alloy was also employed for a comparison with them.

### III. Slection of the Diaphragm

It is difficult to find a suitable material for the diaphragm, in general, since the following properties are usually required :

1. chemical resistivity,
2. convenience for set up, which depends on the geometry of the cell employed,
3. small electrical resistivity, and
4. economical cost, in order that it be obtainable commercially.

In this research unglazed pottery plate, pieces of blue asbestos and white asbestos cloth, some synthetic fabrics, porous synthetic resin plates, and porous rubber sheets were examined in a small 10 amp. cell.\* The conditions employed were as follows :

time during electrolysis	3 hr
total current	10 amp.
terminal voltage	10 volts
concentration of sulfuric acid produced	120 g/l of H <sub>2</sub> SO <sub>4</sub>
current efficiency of the anode reaction	91.4%

Of these, the blue asbestos cloth and the fine rubber sheet, which is used for the lead battery, were selected.

\* For example, the thickness of the fine porous rubber sheet used was 0.5-1.0 mm, and its electrical resistivity was about 0.002 ohm. mm/dm<sup>2</sup>.

The synthetic fabric were also of great use in practice. However, the fabric should be isolated from the anode surface during electrolysis because of anodic oxidation. This property is to be compared with the asbestos and rubber diaphragms which are much more resistant to oxidation than synthetic fabrics. To prevent oxidation a thin glass fiber fabric was usually set up between the diaphragm and anode surfaces as protection from electrochemical attack.

Moreover, the layer diaphragm is favorable to the production of concentrated sulfuric acid. For this purpose two or three sheets were sometimes installed in practice.

#### IV. Electrolysis by the Vertical Rotating Cathode Mercury Cell

Both the process and the type of electrolyser have been discussed in detail. The vertical rotating cathode mercury cell was selected for technical reasons. The research of the electrolysis of sodium sulfate was carried out with several purposes in mind, one of the most important of which is of course to obtain high purity caustic soda which will be used for the rayon industry.

The vertical rotating cathode mercury cell has been investigated and developed as the electrolyser of sodium chloride solution by Okada and his collaborators at Kyoto University<sup>4)</sup>. The cell employed for the electrolysis of the sodium sulfate solution is a modification of Osaka's cell.

The first pilot electrolyser was of 200 amp. scale, the side and front views of the cell being shown in Fig. 1. The inside of the cell was lined with polyvinyl chloride sheet of 0.6 mm thickness. Three steel discs and six lead alloy plates were arranged for the cathode in parallel, that is, each cathode disc was placed between two anode plates. The total area of the cathode surface was

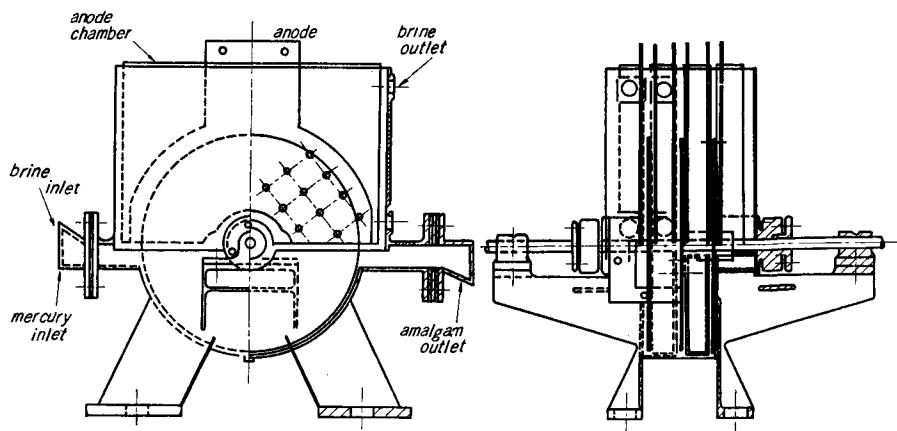

Fig. 1. The side and front views of the 200 amp. electrolyser.

about  $13.2 \text{ dm}^2$ , which corresponds to  $15 \text{ amp/dm}^2$  current density at 200 amp. total current.

Fig. 2 shows the flowsheet for the 200 amp. pilot cell.

The diaphragms to be examined were placed in frames completely separating each anode.

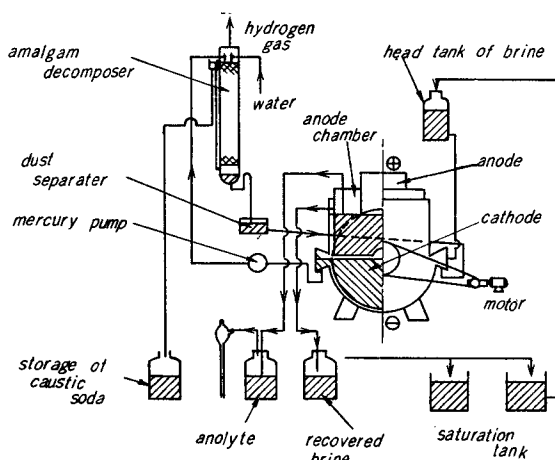

Fig. 2. Flowsheet of the 200 amp. electrolyser.

Crystal sodium sulfate, a by-product of the rayon industry, is supplied to the saturation tank. It must be purified and its concentration, pH-value and temperature must be controlled at  $370 \text{ g/l}$ ,  $7.5\text{--}7.3$ , and  $40^\circ\text{C}$ , respectively. The effluent brine was recycled through the saturation tank.

The main purpose of this experiment was the choice of the best anode material and diaphragm, as well as the observation of the ability of the cell to meet economical and technical requirements.

Table 2 shows the weight decrement of various materials for the anode during electrolysis measured in the 200 amp. cell, from which it was concluded that the alloy, consisting of Ag (2%)-Te (1%)-Pb, is the most desirable anode material from the economic point of view.

Two layers of blue asbestos cloth or three layers of fine porous rubber sheet were used as the diaphragm for the production of sulfuric acid at a concentration of more than  $200 \text{ g/l}$  of  $\text{H}_2\text{SO}_4$ .

Since the vertical electrode is much more convenient for escape of the gas generated at the surface of the electrode than is the horizontal electrode, the terminal voltage is less than 5.0 volts, the current efficiency is 95–98%, and the concentration of sulfuric acid obtained is  $200\text{--}250 \text{ g/l}$  of  $\text{H}_2\text{SO}_4$ .

Table 2. Consumption of anode material of various alloys in the 200 amp. cell operation.

exp. no.	composition of alloy	time of electrolysis (hr)	current (amp)	anode chamber temp. ( $^{\circ}\text{C}$ )	$\text{H}_2\text{SO}_4$ in anolyte (g/l)	consumption of anode material (mg/AH)
4	Ag(10%)–Pb	72	200	60–65	80–100	1.93
5	Ag(2%)–Te(1%)–Pb	50	197	58	70	0.256
6	"	72	150–200	60–70	80	0.581*
7	"	28	200	52	140	0.577*
8	"	45	195	57	160	0.186
9	Ag(2%)–Te(10%)–Pb	53	200	56	190	1.32
10	Ag(2%)–Te(15%)–Pb	5	200	43	50	1.16*
11	"	45	200	—	170	1.36
12	"	20	200	—	150	0.357*
13	Ag(2%)–Te(1%)–Pb	20	200	48	130	1.25

\* weight increased.

Next, a 1500 amp. vertical cell was constructed and operated. Fig. 3 and 4 give the profile of the cell and its flow-sheet, respectively. The sulfuric acid produced was carried away to the outside of the cell by gravity.

The electrolyser was operated over 52 days continuously, and several conditions such as flow of brine, pH-value, temperature, concentrations of sulfuric

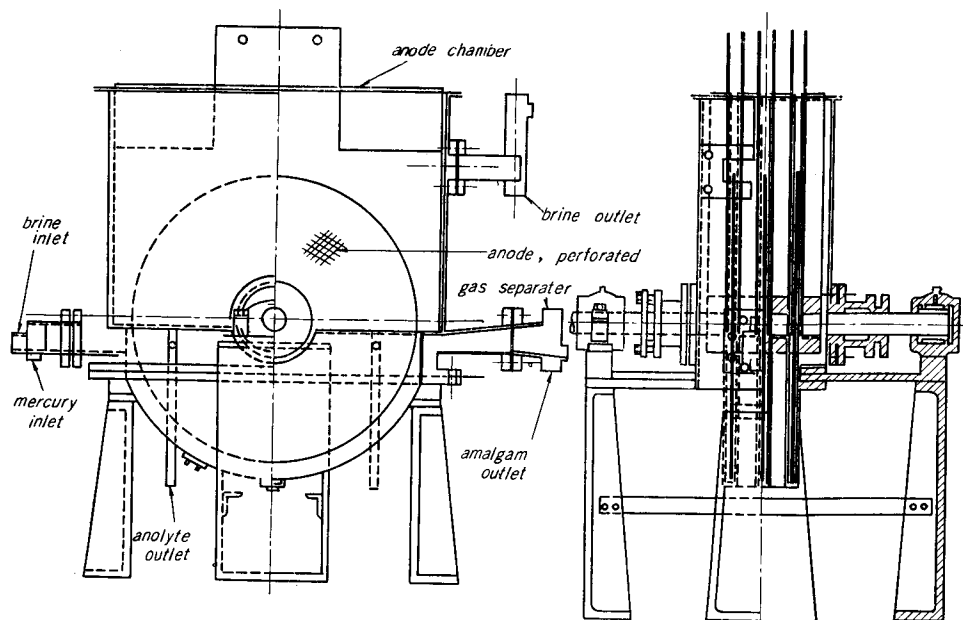

Fig. 3. The side and front views of the 1500 amp. electrolyser,

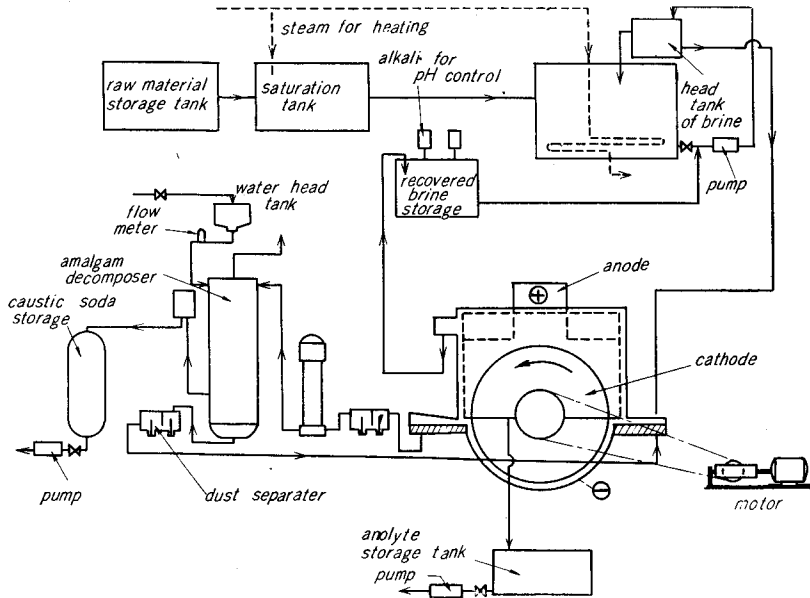

Fig. 4. The flowsheet of the 1500 amp. electrolyser operation.

acid and amalgam, and terminal voltage were observed. Tables 3 and 4 show the optimum conditions and the data obtained from this experiment.

Because 2 mg of anode material was consumed per AH, as determined by an experiment expending 6,759 KAH, it is concluded that over a period of 28 months

Table 3. Optimum conditions for electrolysis.

diaphragm	two layers of blue asbestos cloth or three layers of fine porous rubber sheet
current density	12 amp/dm <sup>2</sup>
total current	1500 amp.
anode to cathode distance	8 mm
velocity of cathode	10 RPM
direction of rotation of cathode	normal direction (see Fig. 6)
flow of brine	1000-1500 cc/min.
temperature	60-70°C
pH of brine at the inlet	7
concentration of brine	400 g/l
percent of brine consumed	10-15%
flow of mercury	1000-1500 cc/min.
concentration of amalgam	0.1-0.15%
brine level above the cathode	50-80 mm
permeability of diaphragm	70-80 cc of brine/hr/dm <sup>2</sup>
temperature of the amalgam decomposer	70-80°C

Fig. 4. Experimental results for the 1500 amp. electrolyser.

current density	12 amp/dm <sup>2</sup>
terminal voltage	4.4-4.6 volts
temperature	50-60°C
feed brine concentration	400-420 g/l Na <sub>2</sub> SO <sub>4</sub>
concentration of caustic soda, obtained	35-45% NaOH
composition of the anolyte	$\left\{ \begin{array}{l} \text{H}_2\text{SO}_4 \\ \text{Na}_2\text{SO}_4 \end{array} \right.$
	230-250 g/l
	220-240 g/l
current efficiency	92-95%
energy consumption	3100-3350 KWH/£ NaOH

a current density of 12 amp/dm<sup>2</sup> will decrease the thickness of the anode by 4 mm.

Neither the blue asbestos cloth nor the fine porous rubber sheet diaphragms were attacked over a three months period without protection of glass fiber, so that they probably could be used for a period of half a year or more if they were isolated from the anode surface.

The purity of the caustic soda obtained was good, similar to that of the chlor-caustic industry, and the sulfuric acid contained but a small amount of lead and a trace of silver.

## V. Operation at High Current Densities

From the economic point of view, more than 30 amp/dm<sup>2</sup> of current density will be necessary to compete with the chlor-caustic industry.

The three factors which contribute most of the potential drop of the cell will be considered: the high anodic overpotential, the voltage drop in the diaphragm, and the ohmic drop in the bulk of the solution especially at the vicinity of the anode because of the suspension of the oxygen gas generated. The overpotential of the anode could be decreased if the gas generated were carried away from the surface of the anode as soon as possible since the majority of the surface of the anode is covered by oxygen gas<sup>5)</sup>. The bubbles also contribute to the ohmic voltage drop in the neighbourhood of the anode indicated above.

The following items were investigated in relation to these problems by using the 1,500 amp. cell.

### (1) The Anode

The possibility of increasing the anode area by making numerous small holes through the electrode for the convenience of the escape of the oxygen gas generated must be considered. The effects of the percentage of area of the holes to the total area of the electrode surface and of the diameter of the holes were



studied. The conditions employed were as follows:

current density	-32 amp/dm <sup>2</sup>
diameter of hole	3-5 mm $\phi$
percentage hole area to total area	-27.4%

From this experiment, a hole area of 6.75-13.8% of the total area seems desirable from both the economic and technical points of view and also in consideration of the strength of the anode.

Furthermore, the consumption of the anode material at a high current density as 32 amp/dm<sup>2</sup> was less than 3.0 mg/AH.

### (2) The Diaphragm

Although a three layer-diaphragm of fine porous rubber sheet was recommended for producing concentrated sulfuric acid at a low current density such as 10 amp/dm<sup>2</sup>, a thinner diaphragm could be employed at a high current density because of the increased production of sulfuric acid per unit volume of the anolyte. The result is that the voltage drop in the diaphragm does not change in proportion to the increase in the current density, as shown in Fig. 5.

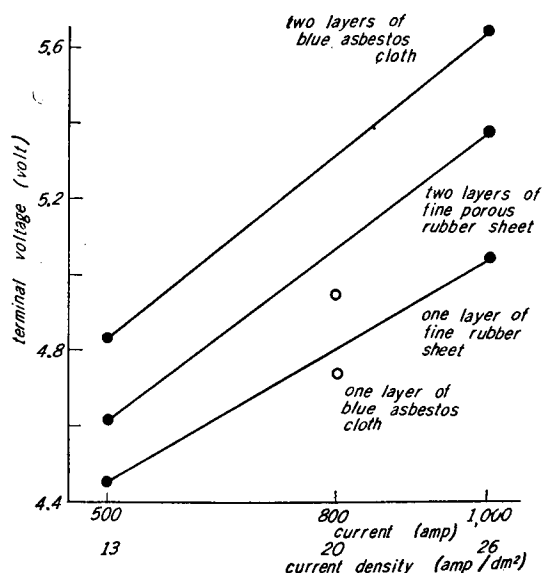

Fig. 5. Relations between number of diaphragms and terminal voltage.

### (3) The Cathode

The cathode was replaced by a "wheel type disc" as shown in Fig. 6. The terminal voltage vs. current diagrams are shown in Fig. 7. The voltage of the

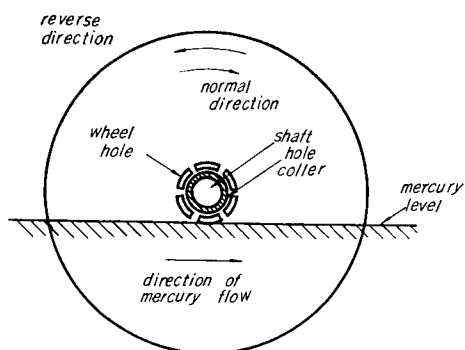

Fig. 6. Schematic of the wheel type cathode.

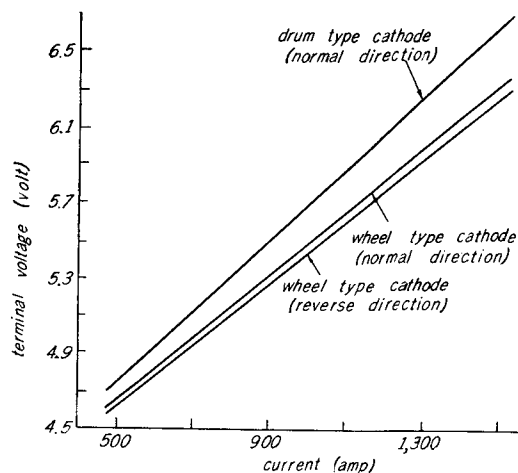

Fig. 7. Relations between current and terminal voltage.

wheel type cathode is considerably lower than that of the drum type cathode, and also it was found that the wheel type cathode is scarcely affected by the velocity of revolution. However, the velocity of revolution and/or the circumferential velocity have certain upper limits because of the splashing of the mercury, and they were estimated to be about 20 R.P.M. and 78 cm/sec, respectively.

Table 5. Consumption of anode material.

current density (amp/dm <sup>2</sup> )	Ag(2%)-Te(1%)-Pb alloy (mg/AH)	Sb-Pb alloy (mg/AH)
32	2.23 (600 amp., 362 hrs.)	19.6-20.6
33.5	2.8 (1290 amp., 17.8 hrs.)	—
38.7	2.8 (1500 amp., 370 hrs.)	—
32	2.4	—

Thus the merits of the wheel type cathode are as follows:

- (1) the discharge of the amalgam sludge is easy,
- (2) distributions of flow and concentration of brine are uniform,
- (3) the range of operating conditions, for example, the number of revolutions of the disc per unit time, is wide, and
- (4) less mercury is required and the cathode area is increased since the structure of the cell is simple.

## VI. Conclusions

- (1) Ag-Te-Pb alloy is the most economical and anti-corrosive material for

the anode in sodium sulfate electrolysis, and its consumption is 2-3 mg/AH at current density of 32 amp/dm<sup>2</sup>.

(2) Both blue asbestos cloth and fine porous rubber sheet are recommended as diaphragms for the electrolysis of sodium sulfate solution. The diaphragm should be isolated from the surface of the anode with glass fiber fabric to protect the diaphragm from anodic oxidation.

(3) The vertical rotating cathode mercury cell is suitable for the electrolysis of sodium sulfate solution.

(4) The cell was operated continuously for a long time under as high current density as 32 amp/dm<sup>2</sup>, and the following results were obtained:

- (a) the thickness of diaphragm can be decreased with increasing current density;
- (b) a perforated anode should be employed, whose holes are 3-5 mm $\phi$  in diameter and contribute 6-15% of the total anode area; and
- (c) the wheel type cathode is better than the drum type cathode for the electrolysis of sodium sulfate solution.

(5) The concentrations of sulfuric acid and caustic soda obtained were 200-250 g/l of H<sub>2</sub>SO<sub>4</sub> and 35~45% of NaOH\*, under a condition of 32 amp/dm<sup>2</sup> current density with continuous operation, the terminal voltage being less than 5.0 volts, and the current efficiency 90-95%.

#### References

- 1) C. Fink, *Trans. Am. Electrochem. Soc.*, **40**, 1 (1921).  
W. W. Stender, et al., *ibid.*, **68**, 493 (1935).
- 2) V. C. Tainton, *Trans. A. I. M. M. E.*, **35**, 192 (1929).
- 2) Fiat Final Report; Nos. 732, 816, 817, 831 (1946).
- 3) Okada, Yoshizawa and Ando, Patent (Japan), 204853; 210923.
- 4) Kyoto University, *Project Report on the Vertical Rotating Cathode Mercury Cell for Electrolysis of Sodium Chloride Solution*. Parts I, II, and III (1951), Japan Soda Industry Association.
- 5) Hine, *Chemical Engineering Studies on Electrolyser*. Series of Technical Reports of Soda Industry, No. 160 (1959), Japan Soda Industry Association.

---

\* It is likely that a more concentrated caustic soda solution can be obtained as same as in the electrolysis of sodium chloride solution.