



TITLE:

Effects of Temperature and Humidity on the Properties of Cement and Mixtures

AUTHOR(S):

Hirano, Masao

CITATION:

Hirano, Masao. Effects of Temperature and Humidity on the Properties of Cement and Mixtures. Memoirs of the College of Engineering, Kyoto Imperial University 1927, 4(5): 261-340

ISSUE DATE:

1927-02-25

URL:

<http://hdl.handle.net/2433/280085>

RIGHT:

Effects of Temperature and Humidity on the Properties of Cement and Mixtures.

By

Masao Hirano.

(Received December 1st, 1926.)

PREFACE.

With the growth of the use of Portland cement as a structural material for various engineering and architectural purposes, the demand for a definite knowledge of the physical properties of mortar and concrete has become more and more urgent, and necessitates a thoroly scientific investigation.

There is a tendency, nowadays, to use various kinds of admistures in mortar and concrete either to save the amount of cement, or to make the mass more dense and reduce the permeability.

A speedy completion of the construction work is generally desired, hence the work is carried out almost every day regardless of the intense heat of summer and of the severe cold of winter, provided certain other conditions do not obstruct.

It is by no means wise to assume that a material peculiarity suited to meet certain conditions at ordinary temperature is able to perform the same duty at a higher or lower temperature. The various properties of mortar and concrete at ordinary temperature, and also at lower temperatures, such as freezing, have been comparatively well investigated. Investigation into the effect of higher temperatures, and especially of humidity, however, has not been so much developed heretofore. So far as the effect of the admixture on the properties of mortar and concrete, it is not fully determined yet. Therefore, the present scribe took it on himself to make a little research to obtain some knowledge on these subjects.

The paper presented here gives the results of the experiments which were carried out by the writer at the Kyoto Imperial University in 1923—1924, in order to investigate the effects of temperature and humidity on the physical properties of cement and its mixtures, putting the chemical properties out of consideration. If the investigation covers some previously uninvestigated phase of these important subjects, and prove to be a helpful contribution to our present meagre knowledge, the writer will be plentifully rewarded for his labours.

February, 1925.

Masao Hirano.

CONTENTS.

Introductory.

Chapter 1.

Effect of heating and quenching upon the strength of mortar and concrete.

1. Purpose of testing.
2. Some experiments carried out previously.
3. Test specimens.
4. Heating equipment and apparatus.
5. Testing.
6. Results of tests.
 - a. Compression test of mortars.
 - b. Compression test of concrete.
 - c. Tension test of neat cement and cement mortar.

Chapter 2.

Distribution of heat through the concrete mass.

1. Purpose and necessity of test.
2. Some remarkable experiments performed in the past.
3. Test specimens and heating apparatus.
4. Testing.
5. Results of tests.
6. Empirical formula showing the rate of heat transmission through the concrete mass.

Chapter 3.

Effects of temperature and humidity upon the time of set in cement.

1. General remarks.
2. Formulas showing the effect of temperature on the setting of cement.
3. Equipment and apparatus.
4. Testing.
5. Results of tests.
 - A. First testing.
 - B. Second testing.
 - C. Effect of admixture.

Chapter 4.

Effects of temperature and humidity upon the strength of mortar and concrete.

1. General remarks.
2. Equipment and apparatus.
3. Test specimens.
4. Testing.
5. Results of tests.
 - A. Effect of temperature.
 - B. Effect of humidity.

Chapter 5.

Thermal expansion of cement mortars with or without an admixture.

1. Purpose of test.
2. Test specimens.
3. Equipment and apparatus.
4. Testing.
5. Results of tests.

General Conclusions.

INTRODUCTORY.

The strength of mortar and concrete is governed primarily by 1) the quality of the cement; 2) the texture of the aggregate; 3) the quantity of cement in a unit volume; 4) the density; 5) the thoroughness of mixing; 6) the age after the molding; 7) the consistency. Besides these there remain various factors affecting or tending to affect the properties of the materials such as a) the temperature at which mortar or concrete is mixed and molded; b) intense heat or severe cold to which the cement is subjected after it had been deposited; c) the humidity amid which it is mixed or subjected after it is deposited; d) the pressure exerted at the molding; e) the impurities contained in the aggregate or in the mixing water; f) the nature and amount of any admixture if used.

To investigate the effect of intense heat and also of the temperature and humidity is specially important in determining the fire resistance of the materials for the former and the setting time for the latter.

In the construction of a concrete structure, it is highly desirable to produce a material of uniform quality. Unfortunately, however, mortar and concrete vary in quality with the character, proportions and mixing of these ingredients, and the strength and other properties suffer a like fluctuation. Hence, under present method of execution, it is very difficult fully to accomplish the perfection aimed at.

In the testing carried out by the writer, all specimens in the same line were mixed, molded and stored under the same conditions as strictly as possible, using the same materials and then tested. Throughout the work, all materials were weighed to insure uniformity and accuracy in proportioning and all specimens were carefully molded so as to secure a dense mass with a smooth surface.

The materials used in the testing were as follows:

- i. Portland Cement. Onoda Portland Cement Co.
- ii. Volcanic ash. Kyushiu Volcanic Ash Co. "Karatsu."
- iii. Infusorial earth. "Keisodo" Produced in Gifu prefecture.
- iv. Hydrated lime. Place of production unknown.

- v. Sand. Two kinds were used.
 - a) Standard sand supplied by the Shinagawa White Brick Co.
 - b) River sand taken from Kidzu River near Uji, Kyoto prefecture. The latter is mainly composed of quartz grains produced from decomposed granite and contains a very small percentage of black mica besides the felspar. It was cleaned, and sieved and mixed in the similar way as the standard sand.
- vi. Gravel. This was taken from the Kamo river in Kyoto city and was mainly composed of hornstone, quartzite and sandstone. The gravel was cleaned and the grains being classified by sieving into sizes from 0'.04 to 0'.02 and from 0'.06 to 0'.04, they were mixed equally.
- vii. Water. The water used for mixing was supplied by the water works of the Kyoto Imperial University.

CHAPTER 1. EFFECT OF HEATING AND QUENCHING UPON THE STRENGTH OF MORTAR AND CONCRETE.

I. PURPOSE OF TESTING.

The purpose of the testing was to determine the fire resisting property of mortar and concrete made with typical materials, and the necessity for and the value of fire-proofing constructions.

In the case of a great fire, buildings and structures made of concrete or coated with mortar are likely to be exposed for several hours to intense heat and it is most desirable to remain the buildings and the structures intact, enduring such a high temperature. Water necessarily accompanies a fire to prevent the flames from spreading, and so the buildings and the structures have to be subjected to the actions both of intense heat and of water cooling. To determine the effect of heating and quenching upon mortar and concrete, therefore, is a fundamental fact of the utmost importance in considering the question of fire resistance.

Experience shows that mortar and concrete are more fire resistant than other building materials and various experiments on this subject have been carried out from time to time by several authorities. Unfortunately, it is very difficult to get definite comparative values from these scattered reports, and the best that can be done is to compare all the results as far as possible so as to get the general idea clearer. It is evident that a good deal of research still remains to be done on the effect of high temperatures upon the strength of mortar and concrete.

2. SOME EXPERIMENTS PREVIOUSLY CARRIED OUT.

Some remarkable experiments in determining the fire-resisting properties of mortar and concrete were carried out by several authorities which will be mentioned below.

i. Bauschinger's tests.⁽¹⁾

In 1884—86 Prof. J. Bauschinger (of Munich) made two series of fire and water tests on building columns that were loaded in a horizontal testing machine and heated by a wood fire in a wrought iron trough placed under them. Water was applied to the top surface. A test with Portland cement mortar was made on a column 30 cm. square and 3 m. long. The proportion of the mixture was 1 : 5 Portland cement and coarse sand. The column was tested at the age of $6\frac{1}{2}$ months under a working load of 95 pounds per square inch. It was heated for $1\frac{3}{4}$ hours until a temperature of 600° C. was obtained at the middle of the sides, when water was applied. No apparent injury resulted, and when cold it was loaded to failure at 920 pound per square inch.

ii. Tests by Mc Farland and Johnson.⁽²⁾

Tests to determine the effect of fire and water on the strength of

(1) Mittheilungen aus den Mech. Tech. Lab. d. k. Tech. Hochschule, München, Heft 12, 1885; Heft 15, 1887.

(2) Engineering News, Vol. 56, Sept. 20, 1906.

reinforced concrete columns were made in 1906 by H. B. Mc Farland and E. V. Johnson at the Chicago laboratory of the National Fire-proofing Company.

The columns, three in number, about $10\frac{1}{2}$ in. square and 12 ft. long, were made of 1 : 2 : 4 limestone concrete, and reinforced with $\frac{3}{8}$ in. rods placed near the corners. Two columns were tested in compression at normal temperature at the age of two months and three and a half months respectively, and sections 5 ft. to 6 ft. long were cut from them outside of the region of failure for use in the fire test. One of these specimens was covered with 3 in. of solid porous clay tile, the other was tested unprotected, and after the fire test subjected to water application. The third column was cut in two, one part for use in the fire test and the other for a comparable compression test at normal temperature. The age of all columns was 23 months at the time of the fire test.

The three specimens were placed on end in a wood-fired furnace and subjected under no load to a 3-hour fire test. Furnace temperature, as indicated by a Bristol thermo-electric pyrometer, ranged from 800 deg. to 1,000 deg. C. for the greater portion of the period. On the day following the fire test they were tested in compression.

The section protected by clay tile was little affected by the test, and developed a compressive strength of 3,127 pounds per square inch. An 18 in. long specimen cut from the same column, but not subjected to fire test, developed 3,558 pounds per square inch. The specimen to which water was applied after the fire test failed in the compression test at 674 pounds per square inch. The column from which it was cut had developed 2,116 pounds per square inch at the age of $3\frac{1}{2}$ months, the fire and water treatment having apparently caused a decided decrease in strength. A similar effect was indicated in the case of the third specimen, its strength being 711 pounds per square inch, against 2,565 pounds per square inch for the section of the same column that was not exposed to fire.

The large reductions in strength sustained by the unprotected columns can be ascribed in part to their small size, larger columns being

subjected to smaller percentage reduction in strength due to surface damage from fire exposure.

iii. German fire tests on reinforced concrete houses.⁽³⁾

The crushing strength of the various kinds of concrete as determined before and after the fire tests in order to ascertain the average loss of strength. Some of these measurements were made on cubes prepared from pieces cut out of the walls before and after the fires. Others were made on 20 cm. cubes prepared in iron moulds from the mixture used in the construction of the two houses. Some of these cubes were placed in the houses with alloys to indicate the temperatures reached during the tests. The aggregate of concrete tested were basalt, granite, gravel, pumice, and blast furnace slag.

The results are not all strictly comparable, since the temperature to which the cubes were exposed varied from 93° C. (granite, gravel, and pumice) to 230° C. (slag), and 412° C. (basalt). Those, however, give the percentage loss of strength on an average as 47 percent for pumice, 40 percent for slag, 23 percent for gravel, 17 percent for granite, and for basalt, curiously enough, an increase.

iv. Tests by Prof. F. C Lea.⁽⁴⁾

Breaking strength of cement.— Tests were made on 2 in. cubes and briquettes with 1 in. waist. During heating, cracks began to appear on the surface of the specimens at 400° C., and these appeared to increase on cooling. The cracking of the tension specimens was most pronounced at the haunches and on the compression specimens at the corners. The specimens were broken immediately they were cool enough to be handled. The tensile specimens all failed at the cracks at the haunches. The "hardness" of the cement was not affected at temperatures below 600° C.

(3) Full report by Dr. Arthur Holmes in *Concrete and Constructional Engineering*, Vol. 15, Nos. 5, 6 and 7, 1920.

(4) *Engineering*, Vol. 110, Aug. 27, 1920.

Complete dehydration of the cement does not certainly take place below this temperature. The strength appears to increase up to a certain point, probably due to the "ageing" effect of temperature. The diminution in strength appeared to depend more upon cracks than upon the diminution of the strength of the cohering materials. Subsequent test indicated that by slowly cooling in the furnace the strength after heating beyond 500° C. was greater than as above.

Breaking strength of concrete.— Test were made on $4\frac{1}{2}$ in. diam. cylinders of concrete made of A. P. cement, Leighton Buzzard sand, and gravel from water Orton. The heating was done in an electrically heated furnace. Cracks commenced on specimens heated for 1 and 2 hours at 430° C. On cooling, the cracks became more noticeable. At 690° C. the crushing strength of the concrete was only 20 percent of its original strength. Up to about 450° C. the concrete appeared to be little affected by the heating, and above this temperature the falling off in strength appeared to be largely due to loss of bond between the materials. Blocks heated to 430° C. and tested while hot were stronger than other blocks heated to the same temperature and allowed to cool. The number of these tests is not sufficient to prove anything definite, but they probably indicate that loss of strength is very largely due to cracks that develop further as the specimen cools. The loss of weight of the blocks was quite small. After heating to a temperature higher than 430° C. the pebbles could be picked out of the mass clean.

v. Woolson's tests.⁽⁵⁾

In 1905—06 Prof. Ira H. Woolson of Columbia University made a series of tests on the fire resistance of concrete. The purpose of the investigation was to determine the strength and elasticity of the different mixtures both with and without heat treatment.

Crushing tests were made on 4 in. and 7 in. cubes and tests for elastic deformation and crushing strength were made on 6 × 6 × 14 in. prisms

(5) Proceedings of Am. Soc. for Testing Materials, Vol. 7, 1907.

of a 1:2:4 mixture of cement, sand and $\frac{3}{4}$ in. broken stone. Three varieties of stone, limestone, trap rock and clean quartz gravel, were used; cinder concrete specimens were also used in the final series.

The initial tests were made on specimens heated to 500° F., and the temperature was increased by 250° F. for each succeeding set, up to 2,250° F. for the final set. In the final test made in 1906, it was decided that instead of raising the specimens very slowly up to a furnace temperature of 1,500° to 2,000° F., as done in the initial tests, it would be best to raise the temperature rapidly to some fixed point, then hold it there for a definite period. A temperature of 1,500 F. was adopted as a fair average and the furnace raised to this temperature in 40 to 60 minuits and held there for the remainder of the test. The heating was done in an oven type of gas furnace. The temperature was measured continuously by a Le Chather pyrometer. Specimens were heated to various temperatures and crushed after cooling.

As results of the testing, the following results were reported. No appreciable effect upon the strength of trap concrete can be noted until a temperature of 750° F. is reached. For limestone concrete, however, heating to 500° F. gave a great loss of strength. The trap was decidedly the strongest mixture both before and after heating. Gravel concrete had moderate strength when unheated, but was a complete failure after heating to 1500° F. even one hour on one side only. Cinder concrete gave the least strength of all—about half that of the trap concrete, with corresponding weakening due to heating. All concrete mixture when heated throughout to a temperature of 1,000° to 1,500° F. will lose a large proportion of their strength and elasticity.

3. TEST SPECIMENS.

Testing was made on the several specimens mentioned in the following list.

A compression test of the mortar was made on a cube having the sectional area of 50 sq. cm., as specified by our governmental regulations and the proportions were :

- 1) Portland cement mortar. 1 : 3 ("cement mortar")
- 2) Portland cement mortar mixed with volcanic ash.
 - a. cement 0.9 : ash 0.1 : sand 3.0 ("0.1 ash mortar")
 - b. cement 0.7 : ash 0.3 : sand 3.0 ("0.3 ash mortar")
 - c. cement 0.5 : ash 0.5 : sand 3.0 ("0.5 ash mortar")
- 3) Portland cement mortar mixed with infusorial earth.
 - a. cement 0.9 : earth 0.1 : sand 3.0 ("0.1 earth mortar")
 - b. cement 0.7 : earth 0.3 : sand 3.0 ("0.3 earth mortar")
 - c. cement 0.5 : earth 0.5 : sand 3.0 ("0.5 earth mortar")

For each proportion 76 specimens were made and divided into 19 sets, each set being composed of four specimens. For both cement and ash mortars the standard sand was used, for the earth mortar, however, river sand had to be used for lack of the former.

Tension tests for neat cement and 1 : 3 cement mortar were made on briquettes having 5 sq. cm. of waist area, as specified by our governmental regulations, and for the latter the standard sand was used. For each kind 114 specimens were made and divided into 19 sets, each being composed of six specimens.

All specimens mentioned above being immediately unmolded, were placed in a metal box, and covered with a wet cloth for the first 24 hours, after which they were stored in fresh water until the completion of the heat treatment.

A compression test of the concrete was made on cylinders, 10 cm. in diameter and 15 cm. in length of a 1 : 2 : 4 mixture of Portland cement, Kidzu river sand and Kamo river gravel. The specimens made were 76 in number and they were divided into 19 sets, each being composed of four specimens. The concrete was mixed moderately wet and well tamped. Each specimen was left for the first three days covered with a wet cloth, after which it was unmolded and stored in damp sand until the completion of the heat treatment.

4. HEATING EQUIPMENT AND APPARATUS.

An electric muffle furnace was used for heating the specimens and

a pyrometer with platinum-rhodium thermo-couple was used for the purpose of measuring the internal temperature of the furnace when the specimens were heated. Fig. 1. *a, b.* shows the general view, form and dimensions of the furnace.

During the tests the front opening of the furnace was covered with a thin plate of pumice called fire-resisting stone ("Kokaseki") named by the late Prof. Dr. W. Watanabe, and packed with asbestos sheets to prevent the escape of heat. The interior temperature of the furnace could be raised up to 900° C. by regulating the rheostat. Up to about 400° C. the temperature could be kept uniform throughout the furnace, beyond that temperature, however, a little difference of temperature between the central and corner parts could not be avoided. Hence, to heat the specimens at always constant temperature even at 400° C. or more only the central part of the furnace was utilized. The pyrometer used for measuring the temperature was carefully checked before the test and corrected.

5. TESTING.

All specimens were tested at the age of 28 days. One in each 19 sets was tested in the normal atmospheric condition. Nine sets were heated to the required temperature in the furnace, after that the strength of each specimen was tested immediately it had been cooled in the air enough to be handled. The nine remaining sets were heated to the required temperature also, after that the specimens were plunged suddenly into cold water and kept there until they were tested.

The initial test on these lines was made on the specimens of the first set heated to 100° C., and for the second set the temperature was raised to 200° C., thus increasing 100° C. for each succeeding set up to 900° C. for the ninth set. The temperature gradient was approximately uniform, raising the temperature at the rate of 100° C. every 30 minutes.

When the furnace temperature reached the required degree of heat, it was kept constant during half an hour, then the specimens were withdrawn from the furnace. Hence, for the specimens heated to 700° C. about four

hours were required. For temperatures below 400° C., eight specimens for the compression test of mortar, and four for the concrete test were put in, and for higher temperatures four for the former and two for the latter placed in the furnace at the central part at the same time in order to heat all the specimens to the same temperature. For the tension test, as the briquettes were small, six specimens were placed in the furnace at same time for every heating temperature. The specimens were so arranged in the furnace as to expose all the surfaces, except of course the bottom one, to the furnace temperature, each one being set somewhat apart from the adjacent one.

A thermo-couple was inserted into the furnace through the crevice at the front opening to indicate the interior temperature to which the specimens were subjected.

About 7 litres of fresh water was kept in a bucket and its temperature maintained at about 17° C. constantly, it being regulated by either putting in pieces of ice or pouring hot water into the bucket. Such water was used for the purpose of quenching. After the specimens had been heated to the required temperature, they were plunged suddenly into the water, two at a time; about three minuits later cold water was poured into the bucket, and immediately the specimens became cool enough to be handled in the water, they were pulled out and stored in the water bath during the 24 hours before testing.

The compressive strength of all specimens was tested by means of an Amsler-Laffon testing machine of 60 tons capacity; and the tensile strength, by a Michaelis testing machine.

6. RESULTS OF TEST.

a. Compression test of mortars.

Tables I—VIII show the results obtained in the testing. The cement mortar test shown in Table V was carried out specially for the comparison with the earth mortar tests used the same river sand. The mean values are taken from three specimens having greater strength values in each set.

Table I.
 Portland cement mortar.
 Proportion 1 : 3 ("Cement mortar").
 Amount of water mixed 7.7%.

Date of testing	No. of set	Molding		Testing			Compressive strength (kg./□cm.)					Strength ratio	Remarks before strength test
		Laboratory temp. (C.)	Water temp. (C.)	Laboratory temp. (C.)	Heating temp. (C.)	Condition	1	2	3	4	Mean		
Jul. 19 1923	1	23.0	21.0	27.0	—	Normal	300.0	316.0	316.0	306.0	312.7	100.00	
" " "	2	"	"	24.5	100.0	Heated	290.0	296.0	282.0	302.0	296.0	94.66	
" " "	3	"	"	"	"	Quenched	258.0	266.0	272.0	265.0	267.7	85.61	
Aug. 10 "	4	26.0	23.0	29.0	200.0	H.	374.0	354.0	348.0	330.0	358.7	114.71	
" " "	5	"	"	"	"	Q.	256.0	294.0	280.0	260.0	278.0	88.90	
" " "	6	"	"	31.0	300.0	H.	392.0	368.0	356.0	376.0	378.7	121.11	
" " "	7	"	"	"	"	Q.	268.0	272.0	276.0	294.0	280.7	89.76	
" 11 "	8	24.0	23.5	30.0	400.0	H.	300.0	276.0	328.0	286.0	304.7	97.44	
" " "	9	"	"	"	"	Q.	254.0	272.0	218.0	246.0	257.3	82.28	
" 13 "	10	25.0	23.0	31.0	500.0	H.	248.0	274.0	264.0	242.0	262.0	83.79	
" " "	11	"	"	"	"	Q.	194.0	186.0	226.0	196.0	205.3	65.65	
" 14 "	12	26.0	24.5	30.0	600.0	H.	200.0	182.0	170.0	180.0	187.3	59.90	
" " "	13	"	"	"	"	Q.	164.0	160.0	170.0	156.0	164.7	52.67	
" 16 "	14	27.0	25.0	31.5	700.0	H.	116.0	134.0	122.0	116.0	124.0	39.64	
" " "	15	"	"	"	"	Q.	106.0	108.0	122.0	116.0	115.3	36.87	
" 18 "	16	"	"	31.0	800.0	H.	106.0	86.0	84.0	100.0	97.3	31.12	Fine cracks appeared
" " "	17	"	"	"	"	Q.	82.0	74.0	76.0	80.0	79.3	25.36	Cracks appeared
" 21 "	18	28.0	"	"	900.0	H.	62.0	60.0	46.0	44.0	56.0	17.91	Friable on edges
" " "	19	"	"	"	"	Q.	21.2	20.0	22.0	21.0	21.4	6.84	Coherence very slight

Table II.

Portland cement mortar mixed with Volcanic ash.

Proportion 0.9 : 0.1 : 3.0 ("0.1 ash mortar").

Amount of water mixed 7.9%.

Date of testing	No. of Set	Molding		Testing			Compressive strength (kg./□cm.)					Strength ratio	Remarks before strength test
		Laboratory temp.(C.)	Water temp.(C.)	Laboratory temp.(C.)	Heating temp.(C.)	Condition	1	2	3	4	Mean		
Aug. 23 1923	20	31.0	26.0	28.5	—	Normal	246.0	280.0	278.0	240.0	268.0	100.00	
Jul. 19 "	21	23.0	21.0	24.5	100.0	Heated	254.0	258.0	266.0	252.0	259.3	96.75	
" " "	22	"	"	"	"	Quenched	224.0	234.0	236.0	220.0	231.3	86.31	
" 24 "	23	24.5	20.5	27.0	200.0	H.	316.0	338.0	320.0	328.0	328.7	122.65	
" " "	24	"	"	"	"	Q.	252.0	248.0	230.0	236.0	245.3	91.52	
Aug. 23 "	25	31.0	26.0	29.0	300.0	H.	334.0	356.0	346.0	344.0	348.7	130.11	
" " "	26	"	"	"	"	Q.	262.0	256.0	250.0	248.0	256.0	95.52	
" 24 "	27	29.5	"	30.0	400.0	H.	302.0	296.0	276.0	292.0	296.7	110.71	
" " "	28	"	"	"	"	Q.	240.0	220.0	228.0	216.0	229.3	85.56	
" 25 "	29	"	26.5	29.0	500.0	H.	253.0	242.0	238.0	254.0	249.7	93.17	
" " "	30	"	"	"	"	Q.	172.0	169.8	167.2	161.2	169.7	63.32	
" 28 "	31	30.0	27.0	31.0	600.0	H.	178.4	167.0	162.0	181.0	175.5	65.49	
" " "	32	"	"	"	"	Q.	128.0	126.8	137.6	141.2	135.6	50.60	
" 30 "	33	29.0	25.5	30.0	700.0	H.	122.0	112.4	120.0	118.6	120.2	44.85	Fine cracks appeared
" " "	34	"	"	"	"	Q.	101.8	99.0	102.0	94.0	100.9	37.65	Cracks appeared
Seo. 3 "	35	32.0	27.0	28.0	800.0	H.	112.0	104.0	116.0	124.0	117.3	43.77	Friable on edges
" " "	36	"	"	"	"	Q.	82.0	94.0	90.0	93.0	92.3	34.44	Coherence slight
" 5 "	37	"	27.5	"	900.0	H.	76.0	74.0	80.0	78.0	78.0	29.10	" "
" " "	38	"	"	"	"	Q.	42.8	44.0	46.2	38.4	44.3	16.53	Coherence very slight

Effects of Temperature and Humidity on the Properties etc.

Table III.

Portland cement mortar mixed with Volcanic ash.

Proportion 0.7 : 0.3 : 3.0 ("0.3 ash mortar").

Amount of water mixed 8.6%.

Date of testing	No. of Set	Molding		Testing			Compressive strength (kg./□cm.)					Strength ratio	Remarks before strength test
		Laboratory temp.(C.)	Water temp.(C.)	Laboratory temp.(C.)	Heating temp.(C.)	Condition	1	2	3	4	Mean		
Sep. 8 1923	39	33.0	28.0	30.0	—	Normal	208.0	242.0	222.0	218.0	221.3	100.00	
Jun. 19 "	40	23.0	21.0	25.0	100.0	Heated	222.8	213.2	225.0	221.4	223.1	1008.0	
" " "	41	"	"	"	"	Quenched	200.0	193.4	193.0	187.2	195.5	88.34	
" 24 "	42	24.5	20.5	28.0	200.0	H.	276.0	274.0	290.0	300.0	288.7	130.63	
" " "	43	"	"	"	"	Q.	208.0	201.0	220.0	223.4	217.1	98.10	
Sep. 7 "	44	23.5	28.0	"	300.0	H.	310.0	308.0	314.0	298.0	310.7	100.40	
" " "	45	"	"	"	"	Q.	214.0	226.0	210.0	228.0	222.7	100.63	
" 8 "	46	33.0	"	29.0	400.0	H.	266.0	264.0	265.0	266.0	265.7	120.06	
" " "	57	"	"	"	"	Q.	200.0	198.0	204.0	210.0	204.7	92.50	
" 10 "	48	35.0	29.0	27.0	500.0	H.	222.0	220.0	224.0	220.0	222.0	100.31	
" " "	49	"	"	"	"	Q.	174.0	178.0	170.0	160.0	176.0	79.53	
" 11 "	50	34.5	28.0	"	600.0	H.	199.7	192.0	182.0	190.0	193.9	87.62	
" " "	51	"	"	"	"	Q.	138.0	134.0	120.0	124.0	132.0	59.65	
" 13 "	52	35.0	"	27.5	700.0	H.	118.0	127.0	139.0	130.0	132.0	59.65	Fine cracks appeared
" " "	53	"	"	"	"	Q.	97.2	92.0	106.0	99.4	100.9	45.59	Cracks appeared
" 15 "	54	34.5	"	26.0	800.0	H.	51.0	49.0	64.0	68.0	61.0	27.56	Friable on edges
" " "	55	"	"	"	"	Q.	37.0	34.0	50.0	48.6	45.2	20.43	Coherence slight
" 18 "	56	31.0	27.0	24.0	900.0	H.	45.0	46.2	45.0	40.0	45.4	20.52	" "
" " "	57	"	"	"	"	Q.	25.8	24.2	28.0	26.0	26.6	12.02	Coherence very slight

Table IV.

Portland cement mortar mixed with Volcanic ash.

Proportion 0.5 : 0.5 : 3.0 ("0.5 ash mortar").

Amount of water mixed 9.3%.

Date of testing	No. of set	Molding		Testing			Compressive strength (kg./□cm.)					Strength ratio	Remarks before strength test
		Laboratory temp.(C.)	Water temp.(C.)	Laboratory temp.(C.)	Heating temp.(C.)	Condition	1	2	3	4	Mean		
Sep. 20 1923	58	32.0	27.5	24.5	—	Normal	185.0	176.0	178.6	179.0	180.9	100.00	
Jun. 19 "	59	23.0	21.0	24.5	100.0	Heated	201.0	178.0	177.4	187.2	188.9	104.31	
" " "	60	"	"	"	"	Quenched	174.0	168.6	166.6	165.6	169.7	93.81	
" 25 "	61	24.5	20.5	28.0	200.0	H.	266.0	270.0	270.0	264.0	268.7	148.50	
" " "	62	"	"	"	"	Q.	184.0	183.0	185.2	186.4	185.2	102.38	
Sep. 20 "	63	32.0	27.5	26.0	300.0	H.	280.0	246.0	276.0	272.0	276.0	152.57	
" " "	64	"	"	"	"	Q.	165.4	162.0	164.0	158.0	163.8	90.55	
" 21 "	65	31.0	27.0	25.0	400.0	H.	218.0	240.0	226.0	228.0	231.3	127.86	
" " "	66	"	"	"	"	Q.	156.0	157.0	144.6	149.0	154.0	85.13	
" 24 "	67	31.5	"	24.5	500.0	H.	196.0	195.6	199.0	180.0	196.9	108.84	
" " "	68	"	"	"	"	Q.	126.6	129.0	136.0	134.6	133.2	73.63	
" 25 "	69	31.0	27.5	"	600.0	H.	158.8	150.4	160.0	160.8	159.9	88.39	
" " "	70	"	"	"	"	Q.	97.2	94.6	100.0	98.0	98.4	54.39	
" 27 "	71	33.0	28.0	23.5	700.0	H.	106.4	99.0	92.0	108.0	104.5	57.77	Fire cracks appeared
" " "	72	"	"	"	"	Q.	55.0	48.8	58.8	55.0	56.3	31.12	Cracks appeared
Oct. 1 "	73	29.0	25.0	22.0	800.0	H.	39.4	43.0	38.9	42.0	41.5	22.94	Friable on edges
" " "	74	"	"	"	"	Q.	25.2	30.0	27.4	26.0	27.8	15.37	Coherence slight
" 3 "	75	26.0	"	23.0	900.0	H.	21.0	22.0	19.8	20.6	21.2	11.72	" "
" " "	76	"	"	"	"	Q.	14.0	13.0	14.8	16.0	14.9	8.24	Coherence very slight

Effects of Temperature and Humidity on the Properties etc.

Table V.

Portland cement mortar.

Proportion 1 : 3 ("Cement mortar").

Amount of water mixed 8.6%.

Date of testing	No. of set	Molding		Testing			Compressive strength (kg/□cm.)					Strength ratio	Remarks before strength test
		Labo- ratory temp.(C.)	Water temp.(C.)	Labo- ratory temp.(C.)	Heating temp.(C.)	Condition	1	2	3	4	Mean		
Feb. 18 1924	134	6.5	6.5	6.5	—	Normal	203.2	195.2	211.0	212.0	208.7	100.00	
" 13 "	135	8.5	"	4.0	100.0	Heated	254.0	250.4	229.0	244.6	249.7	119.65	
" " "	136	"	"	"	"	Quenched	217.2	219.0	215.8	216.2	217.5	104.22	
" 14 "	137	8.0	6.0	6.0	200.0	H.	294.0	274.0	256.0	262.0	276.7	132.25	
" " "	138	"	"	"	"	Q.	200.4	182.0	198.0	185.2	194.5	93.20	
" " "	139	"	"	8.0	300.0	H.	268.0	290.0	292.0	288.0	290.0	138.96	
" " "	140	"	"	"	"	Q.	181.8	181.4	271.2	190.0	197.7	94.73	
" 13 "	141	8.5	6.5	7.0	400.0	H.	268.0	256.0	274.0	256.0	266.0	127.46	
" " "	142	"	"	"	"	Q.	181.6	172.4	160.2	164.8	172.9	82.85	
" 12 "	143	7.5	6.0	5.5	500.0	H.	244.0	258.0	248.0	262.0	256.0	122.66	
" " "	144	"	"	"	"	Q.	125.0	148.6	128.6	150.2	142.5	68.28	
" 16 "	145	9.5	6.5	5.0	600.0	H.	144.8	152.6	157.8	157.0	155.8	74.65	
" " "	146	"	"	"	"	Q.	96.6	97.0	89.0	89.2	94.3	45.18	
" 19 "	147	8.0	7.0	6.0	700.0	H.	123.6	117.0	134.4	129.4	129.1	61.86	
" " "	148	"	"	"	"	Q.	70.8	78.0	74.0	72.2	75.1	35.98	
" 21 "	149	7.0	4.0	5.0	800.0	H.	100.0	113.0	90.0	104.4	105.8	50.66	
" " "	150	"	"	"	"	Q.	47.2	46.4	54.0	30.0	49.2	23.57	
" 9 "	151	5.5	4.5	7.5	900.0	H.	71.2	67.4	77.2	71.4	73.3	35.12	
" " "	152	"	"	"	"	Q.	12.2	14.8	14.6	12.6	14.0	6.71	Fine cracks appeared

Table VI.

Portland cement mortar mixed with Infusorial earth.

Proportion 0.9 : 0.1 : 3.0 ("0.1 earth mortar").

Amount of water mixed 10%.

Date of testing	No. of set	Molding		Testing			Compressive strength (kg./□cm.)					Strength ratio	Remarks before strength test
		Laboratory temp. (C.)	Water temp. (C.)	Laboratory temp. (C.)	Heating temp. (C.)	Condition	1	2	3	4	Mean		
Nov. 6 1923	77	20.0	18.5	15.5	—	Normal	244.0	290.0	260.0	262.0	270.7	100.00	
" " "	78	"	"	17.0	100.0	Heated	268.0	276.0	270.0	280.0	275.3	101.70	
" " "	79	"	"	"	"	Quenched	250.0	240.0	264.0	262.0	258.7	95.57	
" " "	80	"	"	18.0	200.0	H.	294.0	318.0	296.0	316.0	310.0	114.52	
" " "	81	"	"	"	"	Q.	260.0	276.0	278.0	264.0	272.7	100.74	
" 7 "	82	18.0	17.5	16.5	300.0	H.	408.0	436.0	422.0	418.0	425.3	157.11	
" " "	83	"	"	"	"	Q.	306.0	270.0	276.0	280.0	287.3	106.13	
" " "	84	"	"	17.0	400.0	H.	350.0	354.0	358.0	370.0	360.7	133.25	
" " "	85	"	"	"	"	Q.	238.0	236.0	220.0	224.0	282.7	85.96	
" 3 "	86	21.5	20.5	"	500.0	H.	273.0	296.0	294.0	268.0	287.7	106.28	
" " "	87	"	"	"	"	Q.	186.0	182.0	184.0	188.0	186.0	68.71	
" 8 "	88	17.5	16.0	15.0	600.0	H.	232.0	228.0	212.0	224.0	228.0	84.23	
" " "	89	"	"	"	"	Q.	154.0	153.0	147.0	154.4	153.8	56.82	
" 12 "	90	20.5	18.5	10.0	700.0	H.	191.4	186.4	178.0	186.0	187.9	69.42	
" " "	91	"	"	"	"	Q.	118.8	113.0	92.0	108.0	113.3	41.85	
" 15 "	92	20.0	17.0	13.0	800.0	H.	86.0	74.0	80.0	78.0	81.3	30.03	
" " "	93	"	"	"	"	Q.	48.0	46.0	49.2	54.0	50.4	18.62	
" 17 "	94	18.5	16.0	14.0	900.0	H.	53.8	50.6	48.4	49.4	51.3	18.95	
" " "	95	"	"	"	"	Q.	30.6	35.2	34.2	32.0	33.8	12.49	Fine cracks appeared

Effects of Temperature and Humidity on the Properties etc.

Table VII.

Portland cement mortar mixed with Infusorial earth.

Proportion 0.7 : 0.3 : 3.0 ("0.3 earth mortar").

Amount of water mixed 15%.

Date of testing	No. of Set	Molding		Testing			Compressive Strength (kg./□cm.)					Strength ratio	Remarks before strength test
		Laboratory temp. (C.)	Water temp. (C.)	Laboratory temp. (C.)	Heating temp. (C.)	Condition	1	2	3	4	Mean		
Nov. 21 1923	96	17.0	15.0	13.5	—	Normal	149.8	151.6	147.4	148.0	149.8	100.00	
" " "	97	"	"	14.0	100.0	Heated	161.8	174.4	180.0	167.2	173.9	116.09	
" " "	98	"	"	"	"	Quenched	156.8	151.4	148.0	154.0	154.1	102.87	
" " "	99	"	"	14.5	200.0	H.	221.2	223.8	221.0	232.2	225.7	150.66	
" " "	100	"	"	"	"	Q.	205.6	207.0	206.8	206.2	206.7	137.98	
" 22 "	101	17.5	15.5	12.0	300.0	H.	260.0	266.0	270.0	256.0	265.3	177.10	
" " "	102	"	"	"	"	Q.	206.0	202.4	200.8	198.0	203.1	135.58	
" " "	103	"	"	14.0	400.0	H.	256.0	260.0	284.0	250.0	266.7	178.04	
" " "	104	"	"	"	"	Q.	182.8	173.2	171.6	178.8	178.3	119.03	
" 23 "	105	16.5	14.5	"	500.0	H.	210.6	214.4	220.0	246.0	226.8	151.40	
" " "	106	"	"	"	"	Q.	163.2	159.2	172.0	152.0	164.8	110.01	
" 24 "	107	"	15.0	"	600.0	H.	210.8	197.0	210.0	224.0	214.9	143.46	
" " "	108	"	"	"	"	Q.	121.0	101.0	122.4	110.0	117.8	78.64	
" 27 "	109	20.5	17.5	"	700.0	H.	50.0	44.0	41.0	53.4	49.1	32.78	Cracks appeared
" " "	110	"	"	"	"	Q.	28.0	40.8	34.6	39.2	38.2	25.50	Friable on edges
" 30 "	111	20.0	18.0	11.0	800.0	H.	29.0	80.8	31.4	30.6	30.9	20.63	Coherence slight
" " "	112	"	"	"	"	Q.	24.6	25.8	26.8	25.0	25.9	17.29	"
" 3 "	113	16.5	15.5	11.5	900.0	H.	26.0	29.8	28.2	27.6	28.5	19.03	"
Dec. " "	114	"	"	"	"	Q.	24.0	22.0	20.5	24.4	23.5	15.69	Coherence very slight

Table VIII.

Portland cement mortar mixed with Infusorial earth.

Proportion 0.5 : 0.5 : 3.0 ("0.5 earth mortar").

Amount of water mixed 18.9%.

Date of testing	No. of set	Molding		Testing			Compressive strength (kg./□cm.)					Strength ratio	Remarks before strength test
		Labo-ratory temp. (C.)	Water temp. (C.)	Labo-ratory temp. (C.)	Heating temp. (C.)	Condition	1	2	3	4	Mean		
Dec. 4 1923	115	15.5	15.0	10.5	—	Normal	71.4	67.0	74.3	68.4	71.4	100.00	
" 5 "	116	17.5	15.5	10.0	100.0	Heated	91.2	91.6	73.8	80.8	87.9	123.11	
" " "	117	"	"	"	"	Quenched	81.8	74.0	71.6	74.4	76.7	107.42	
" " "	118	"	"	11.0	200.0	H.	140.0	135.0	144.8	126.8	139.9	195.94	
" " "	119	"	"	"	"	Q.	134.8	126.2	126.8	138.0	133.2	186.55	
" 6 "	120	16.5	"	12.0	300.0	H.	149.2	160.0	158.0	155.0	157.7	220.87	
" " "	121	"	"	"	"	Q.	137.0	140.8	134.0	136.6	138.1	193.42	
" " "	122	"	"	"	400.0	H.	165.8	174.8	172.4	166.0	171.1	239.64	
" " "	123	"	"	"	"	Q.	134.0	127.0	132.6	131.6	132.7	185.85	
" 7 "	124	13.0	12.5	"	500.0	H.	180.0	176.2	177.4	173.0	177.9	249.16	
" " "	125	"	"	"	"	Q.	112.4	109.0	105.2	101.4	108.9	152.52	
" 8 "	126	"	10.0	14.0	600.0	H.	120.0	104.6	124.0	117.4	120.5	168.77	
" " "	127	"	"	"	"	Q.	70.6	75.6	81.0	76.4	77.7	108.82	
" 11 "	128	14.0	12.5	11.0	700.0	H.	42.0	56.0	36.8	48.0	48.7	68.21	Cracks appeared
" " "	129	"	"	"	"	Q.	25.6	37.0	48.2	27.0	37.4	52.38	Friable on edges
" 13 "	130	12.0	11.5	"	800.0	H.	23.8	25.4	27.4	24.4	25.7	35.99	Coherence slight
" " "	231	"	"	"	"	Q.	22.0	24.0	24.6	26.8	25.1	35.15	" "
" 15 "	132	11.5	9.5	12.0	900.0	H.	19.2	20.2	19.6	22.0	20.6	28.85	" "
" " "	133	"	"	"	"	Q.	20.0	22.0	18.6	18.4	20.2	28.29	Coherence very slight

Effects of Temperature and Humidity on the Properties etc.

The strength ratio is the ratio of the strength of mortar with either heating or quenching treatment to that of similar mortar without such treatment, expressed as percentage.

Figs 2 and 3 are curve sheets showing the variation of strength with relation to heating temperature. These are not comparable owing to the fact that they were put up with different kinds of sand.

For heated condition, the strength in almost every mortar increases up to 300°C. heating temperature and then it decreases until the final temperature. Up to about 400°—550° C. for the mortar using the standard sand and about 500°—650° C. for the mortar using river sand, the strength appears not to be affected by the heating only and beyond the temperatures mentioned the falling off in strength appears to be largely due to loss of bond between the materials. Temperatures at which the strength of the mortars was unaffected are approximately as follows :

Cement mortar A*,	400° C.,	Cement mortar B*,	550° C.
0.1 ash mortar,	450° „	0.1 earth mortar,	520° „
0.3 „ „	500° „	0.3 „ „	640° „
0.5 „ „	550° „	0.5 „ „	670° „

Thus we see that the temperature at which the mortar is unaffected rises in accordance with the smaller original strength in the mortar which depends generally on the smaller amount of cement in the mixture, except the one containing a comparatively small amount of infusorial earth such as 0.1.

By the heating the greatest strength in each mortar is obtained at 300° C. except the 0.5 earth mortar which has a maximum value at 500° C. The percentage gains of the strength are as follows :

Cement mortar A,	21%	Cement mortar B,	39%
0.1 ash mortar,	30%	0.1 earth mortar,	57%
0.3 „ „	40%	0.3 „ „	77%
0.5 „ „	53%	0.5 „ „	149%

* A, Standard sand used.

* B, River sand used.

The greatest strength ratio is raised generally in accordance with the smaller amount of cement in the mixture.

Quenching always reduces the strength got by heating. The strength in cement mortars, both A and B, is lowered at any temperature by quenching except that the latter has a slightly raised value at 100° C. Ash mortar has also less value generally than the normal strength except that 0.3 at 300° C. and 0.5 at 200° C. are not much affected in regard to strength. Earth mortar, on the contrary, gain strength in some temperatures. The greatest strength is obtained at 300° for 0.1 and 0.5, and at 200° C. for 0.3 earth mortar. Temperatures having no effect upon the strength of earth mortar are 330° for 0.1, 530° for 0.3, and 620° C. for 0.5, the temperature rises higher the less cement there is in the mixture.

From the fact that for either heated or quenched condition the greatest strength in each mortar is generally obtained at about 300° C. heating temperature, it is probable that the dehydration of the cement is caused at such a temperature and the falling off the strength begins beyond that temperature, i.e., 300° C.

The normal strength of cement mortar A is 312.7 kg. per sq. cm. By heating up to 900° C. it is reduced to 56.0 kg. per sq. cm., which is about 18% of the former and by quenching at this temperature, the strength is reduced to 21.4 kg. per sq. cm. which is only 7% of normal strength. As for cement mortar B, its normal strength is reduced to about 35% by heating up to 900° C. and to 7% by quenching at this temperature. The loss of strength in each mortar by heating, but especially by quenching at a high temperature such as 800° or more, is decidedly great.

For the relative effectiveness of the different admixtures when compared with the cement mortar using the same kind of sand, it will be seen from the results that for the ash mortar the strength decreases generally in accordance with the amount of ash in the mixture; up to 500° C. (900° C. for 0.1) the strength ratio of all ash mortar is always greater than that of cement mortars, both heated and quenched, and that for the earth mortar, the one containing a small amount of infusorial earth such as 0.1 has a strength greater than all the other cement and earth mortars; and the strength

of mortar containing a great amount of infusorial earth decreases generally in accordance with the amount of earth in the mixture; up to 600°C. the strength ratio of all earth mortars is greater than that of cement mortars both heated and quenched.

Owing to the fact that the loss of strength in ash and earth mortars due to heating and quenching up to 600° C. is generally less than that of cement mortars, we may say that the mortar containing an admixture such as volcanic ash or infusorial earth, is more fire resistant relatively than the cement mortar in some region of the heating temperature and specially is the mortar containing a smaller amount of infusorial earth most fire resistant up to 800° C. at the age of four weeks.

In the testing, fine cracks appeared horizontally in the specimens specially near the corner when they were heated up to 800° or 900° C. for cement mortar and 700° C. for ash and earth mortars, more remarkably when quenched, and specimens exposed to such a high temperature crumbled into powder when slightly pressure was applied with the testing machine.

Fig 4 shows how the different kinds of sand used for cement mortar affect its strength, and the general forms of curve showing the variations of strength at different heating temperatures not differing so much.

b. Compression test of concrete.

Table IX shows the results obtained in the testing and Fig. 5 is a curve sheet showing the variation of strength with relation to heating temperature.

By heating, the compressive strength of the concrete is increased up to 400° C. and having reached the maximum value at this temperature, it begins to decrease and continues to a final temperature of 900° C. The maximum value is 176.1 kg. per sq. cm., about 50% greater than the normal strength and the minimum value at 900° C. is 17.4 kg. per sq. cm., the strength ratio being 14.77%.

Quenching reduces the strength of concrete got by heating even as with mortars. By quenching, the concrete has the maximum value at

Table IX.
 Portland cement concrete.
 Proportion 1 : 2 : 4.
 Amount of water mixed 6.66%.

Date of testing	No. of set	Molding		Testing			Compressive strength					Strength ratio	Remarks before strength test
		Laboratory temp. (C.)	Water temp. (C.)	Laboratory temp. (C.)	Heating temp. (C.)	Condition	1	2	3	4	Mean		
Dec. 18 1923	1	12.0	12.0	7.5	—	Normal	kg./100cm. dia. 10500	" 9570	" 6480	" 7690	kg./□cm. 117.8	100.00	
" 20 "	2	11.5	11.0	11.0	100.0	Heated	11850	12100	10800	12900	156.4	132.78	
" 22 "	3	12.5	12.0	13.0	"	Quenched	9450	9700	8740	9900	123.3	104.67	
May 29 "	4	21.0	18.0	17.5	200.0	H.	11800	12000	9700	11400	149.4	126.83	
" 24 "	5	7.0	5.0	7.5	"	Q.	8620	8670	10850	11420	131.3	111.46	
Feb. 7 "	6	4.5	6.0	8.5	300.0	H.	8320	12800	11570	12040	154.5	131.15	
Mar. 8 "	7	8.0	6.5	7.0	"	Q.	7480	8980	11480	6850	118.6	100.68	
" 29 "	8	7.0	5.5	8.5	400.0	H.	14500	15000	10950	12000	176.1	149.49	
" 31 "	9	7.0	5.5	10.0	"	Q.	7750	7940	6350	8100	101.0	85.74	
Jan. 11 "	10	11.0	10.0	7.0	500.0	H.	10340	11000	11950	12000	148.3	125.87	
" 14 "	11	11.0	9.0	7.0	"	Q.	7000	5230	5800	6970	83.9	71.22	
May 31 "	12	20.5	18.5	18.0	600.0	H.	8540	5980	7300	6700	95.7	81.24	
Jan. 18 "	13	12.0	8.5	10.0	"	Q.	4000	3760	4100	4500	53.5	45.42	
Mar. 11 "	14	9.0	6.0	7.0	700.0	H.	6880	7100	7600	5260	91.6	77.76	
" 20 "	15	6.0	5.5	3.5	"	Q.	3100	2870	2200	2480	35.9	30.48	
" 26 "	16	7.0	5.5	6.0	700.0	H.	3460	3940	3950	5400	56.4	47.88	
" 28 "	17	7.5	5.0	8.0	"	Q.	840	660	1050	850	11.6	9.85	
Dec. 25 "	18	13.0	12.0	4.0	800.0	H.	1580	1000	1030	1500	17.4	14.77	
" 27 "	19	11.0	10.5	8.0	"	Q.	400	500	450	420	5.8	4.92	

200° C., the strength being increased up to this temperature, and then it decreases rapidly at about a uniform rate up to the final temperature. The maximum value is 131.3 kg. per sq. cm., about 11.5% greater than the normal strength, and the minimum value is 5.8 kg. per sq. cm., the strength ratio being only 4.92%.

Thus we see that concrete gains strength up to about 500° C. by heating, and up to about 300° C. by quenching; at higher temperatures, however, it loses strength.

By comparing the strength ratio of the concrete with that of the cement mortar B, we see also that the former is more fire resistant than the latter up to 700° C. It is, however, not conclusive, since the fire resisting property depends mostly on the nature of the coarse aggregate used in the concrete.

c. Tensile test of neat cement and cement mortar.

Tables X and XI show the results obtained by the testing. The mean values are taken from four specimens from each set having the greatest strength values in that set.

Fig. 6 is a curve sheet showing the variation of strength with relation to heating temperature.

By heating, the tensile strength of neat cement is decreased up to 200° and then being increased up to 300° C., it begins to be decreased again and so continues to the final temperature. The maximum strength at 300° C. is 65.1 kg. per sq. cm., about 1% less than the normal strength and the minimum strength at 900° C. is 3.7 kg. per sq. cm., the strength ratio being only 5.6%. By quenching the strength is always decreased and at 800° C. or a higher temperatures it is entirely lost.

Cement mortar has its maximum strengths at 100° C. both by heating and by quenching and then the strength continues to decrease gradually up to the final temperature. The maximum value is 36.0 kg. per sq. cm. for the heated condition, and 26.9 kg. per sq. cm. for the quenched condition, the strength ratio being 142.86% for the former, and 106.75% for the latter, both greater than the normal strength. The minimum value

Tabel X.

Neat cement.

Amount of water mixed 12%.

Date of testing	No. of set	Molding		Testing			Tensile strength (kg./□cm.)							Strength ratio	Remarks before strength test
		Laboratory temp. (C.)	Water temp. (C.)	Laboratory temp. (C.)	Heating temp. (C.)	Condition	1	2	3	4	5	6	Mean		
May 22 1924	1	20.0	16.5	17.5	—	Normal	69.0	61.9	63.7	60.0	64.5	62.0	65.8	100.00	
" " "	2	"	"	"	100.0	Heated	58.6	52.0	45.0	58.3	44.8	49.7	54.7	83.13	
" " "	3	"	"	"	"	Quenched	43.4	39.5	54.5	53.3	48.5	57.3	53.4	81.15	
" 23 "	4	19.5	"	19.5	200.0	H.	44.7	41.1	41.6	40.9	45.4	39.8	43.2	65.65	
" " "	5	"	"	"	"	Q.	36.5	30.5	39.9	46.0	42.0	40.4	42.1	63.98	
" 26 "	6	17.0	14.0	17.0	300.0	H.	59.3	65.9	66.2	65.5	62.6	62.5	65.1	98.93	
" " "	7	"	"	"	"	Q.	27.7	35.9	35.5	28.3	34.6	30.0	34.0	51.67	
" " "	8	"	"	"	400.0	H.	53.0	51.2	54.8	48.5	50.2	51.6	52.7	80.09	
" " "	9	"	"	"	"	Q.	17.1	23.4	22.6	18.9	22.4	22.8	22.8	34.65	
" 23 "	10	19.5	16.5	19.5	500.0	H.	11.4	10.8	10.4	10.5	9.0	11.7	11.1	16.87	
" " "	11	"	"	"	"	Q.	9.0	7.5	11.4	5.2	5.8	6.0	8.5	12.92	
" 22 "	12	20.0	"	17.5	600.0	H.	10.3	8.6	6.8	8.2	10.2	7.6	9.3	14.13	
" " "	13	"	"	"	f ₁	Q.	8.2	5.9	5.0	8.7	5.6	6.8	7.4	11.25	
" 27 "	14	17.0	13.5	"	700.0	H.	14.4	11.4	10.7	17.6	12.3	15.2	14.9	22.64	
" " "	15	"	"	"	"	Q.	3.0	2.3	1.9	2.5	2.0	1.7	2.5	3.80	Fine cracks appeared
" 28 "	16	19.0	16.0	17.0	800.0	H.	8.9	8.0	7.7	8.8	9.7	7.3	8.9	13.53	"
" " "	17	"	"	"	"	Q.	0	0	0	0	0	0	0	0	Coherence completely lost
" 24 "	18	18.0	14.5	19.0	900.0	H.	3.1	3.0	4.0	4.2	3.5	3.0	3.7	5.62	Cracks appeared
" " "	19	"	"	"	"	Q.	0	0	0	0	0	0	0	0	Coherence completely lost

Effects of Temperature and Humidity on the Properties etc.

Table XI.
Portland cement mortar.
Proportion 1 : 3.
Amount of water mixed 7.1%.

Date of testing	No. of set	Molding		Testing			Tensile strength (kg./□cm.)							Strength ratio	Remarks before strength test
		Labo-ratory temp.(C.)	Water temp.(C.)	Labo-ratory temp.(C.)	Heating temp.(C.)	Condition	1	2	3	4	5	6	Mean		
Mar. 27 1924	20	9.0	6.5	6.5	—	Normal	22.1	24.8	24.7	24.8	23.2	26.3	25.2	100.00	
May 22 "	21	20.0	16.5	17.5	100.0	Heated	34.6	38.6	32.5	32.5	36.2	34.6	36.0	142.86	
" " "	22	"	"	"	"	Quenched	24.2	20.4	26.6	23.3	27.9	28.8	26.9	106.75	
Mar. 12 "	23	5.0	5.0	7.0	200.0	H.	29.6	34.4	34.5	33.2	34.1	28.5	34.1	135.32	
" " "	24	"	"	"	"	Q.	23.0	21.6	20.5	20.0	24.1	22.7	22.9	90.87	
" 27 "	25	6.5	6.5	8.5	300.0	H.	24.9	19.7	22.0	21.1	22.0	23.3	23.3	92.46	
" " "	26	"	"	"	"	Q.	13.8	15.2	15.0	13.4	13.7	12.3	14.4	57.14	
" " "	27	"	"	8.5	400.0	H.	19.3	17.2	18.0	17.5	18.8	16.9	18.4	73.02	
" " "	28	"	"	"	"	Q.	9.0	10.2	11.5	11.1	9.9	12.5	11.3	44.84	
" 13 "	29	5.0	5.0	6.5	500.0	H.	10.6	13.1	15.0	10.0	14.5	12.9	13.9	55.16	
" " "	30	"	"	"	"	Q.	6.8	7.4	9.0	6.3	7.4	9.3	8.3	32.94	
" 14 "	31	4.5	4.5	5.0	600.0	H.	7.3	7.4	6.5	7.0	6.6	7.4	7.3	28.97	
" " "	32	"	"	"	"	Q.	4.6	3.5	3.9	3.8	3.5	3.0	4.0	15.87	
" 20 "	38	5.5	5.5	4.0	700.0	H.	3.7	4.9	4.3	3.5	3.5	3.7	4.2	16.67	
" " "	34	"	"	"	"	Q.	3.4	3.9	3.2	2.3	4.0	3.1	3.6	14.29	Fine cracks appeared
" 26 "	35	4.0	4.0	6.0	800.0	H.	4.3	3.9	4.0	3.5	4.0	4.1	4.1	16.27	"
" " "	36	"	"	"	"	Q.	2.1	2.3	2.0	2.3	2.0	1.9	2.2	8.73	Coherence slight
Apr. 1 "	37	5.0	5.0	11.5	900.0	H.	2.3	2.1	2.3	3.0	2.5	2.6	2.6	10.32	"
" " "	38	"	"	"	"	Q.	0	0	0	0	0	0	0	0	Coherence completely lost

at 900° C. for the heated condition is 2.6 kg. per sq. cm., the strength ratio being only 10.32% and for the quenched condition at this temperature the strength is entirely lost.

Thus we see that neat cement always loses its tensile strength both by heating and by quenching, the cement mortar, however, gains strength up to 200° C. or more by heating and up to 100° C. or more by quenching, and so we may conclude that the cement mortar is more fire resistant relatively than the neat cement, the strength ratio of the former being greater in almost every case than that of the latter.

CHAPTER 2. DISTRIBUTION OF HEAT THROUGH THE CONCRETE MASS.

I. PURPOSE AND NECESSITY OF TEST.

The purpose of the testing was to determine the distribution of heat in the portland cement concrete when the surface was heated and the influence of the various proportions of concrete on the distribution of heat.

It is well known that concrete is a bad conductor of heat and several experiences and some experiments have shown us that that notion is correct. It is, however, quite possible that the reinforcing steel imbedded near the surface in the concrete may be subjected to a dangerous temperature in the case of a great fire, owing to the conduction of heat through the protecting coat.

In calculation of the deformation due to temperature change in the concrete structure, it is usual to assume the concrete being subjected to a uniform temperature throughout the whole mass. This is evidently incorrect specially for massive concrete work, as we may suppose that there is a great difference in temperature between the part near the surface and the interior part.

The conductivity may depend upon the nature of the aggregate used in the concrete. If the aggregate is such that chemical changes take place when certain temperatures are reached, or if one aggregate is a better

non-conductor than another then the rate of the progress of temperature from the heated surface towards the centre of the element of the structure may be very different in accordance with these facts.

These factors necessitate the test on the distribution of heat through the concrete.

With regard to the influence of the different proportions of concrete on the heat distribution the author had not the least notion of it and he was much interested to determine what it might be, using the same materials for the test specimens.

2. SOME REMARKABLE EXPERIMENTS PERFORMED IN THE PAST.

Prof. F. C. Lea⁽⁶⁾ carried out a few experiments in order to get some information on the effect of temperature upon the reinforcing steel in the concrete owing to the conduction of heat through the protecting coat. The testing was made on neat cement, 1:3 mortar and 1:2:4 concrete. The specimens were in the form of cylinders of $4\frac{1}{2}$ inches and 2 inches in diameter, 6 inches long, a cube of 4 in. by 4 in. by 4 in. The heating was done in an electric furnace, and temperature was measured by thermocouples which had been made to touch the face or imbedded at different distances from one face of the specimens. The results of these test, though by no means conclusive, indicate that the usual thickness of covering for the steel is by no means sufficient to prevent the dangerous temperature of 650° C. for the steel being reached in those cases where the fire can maintain a high temperature for several hours, and as far as the tests go, they appear to indicate that not a great deal of difference is to be expected by varying the aggregate, unless materials are used which change chemically below 650° C.

Prof. I. H. Woolson⁽⁷⁾ carried out some experiments in 1905—1906 on the conductivity of concrete and of imbedded steel. Conductivity tests

(6) Engineering, Aug. 27, 1920. Vol. 110.

(7) American Society for Testing Materials, Vol. 7, 1907.

for concrete were made on a specimen which was provided with a series of holes running in from the rear face to points at definite distances from the front face to which heat was applied.

Two specimens of each mixture were made. Fig. 7 gives the size of the blocks, and location of the holes in which the therms-couples were placed. The blocks were placed for test in the gas furnace doorway. The aggregate used was a 1 : 2 : 4 mixture of cement, sharp sand, and $\frac{3}{4}$ inch crushed trap rock, or a corresponding size of clear quartz gravel. In the cinder mixture the proportion was changed to 1 : 2 : 5.

The conclusions were: That all concretes have a very low thermal-conductivity, and herein lies their ability to resist fire. That when the surface of a mass of concrete is exposed for hours to a high heat, the temperature of the concrete one inch or less beneath the surface will be several hundred degrees below the outside. That a point two inches beneath the surface would stand an outside temperature of 1500° F. for two hours, with a rise of only 500 to 700° F., and points with three or more inches of protection would scarcely be heated above the boiling point of water.

For conductivity tests of imbedded steel, the specimens were made by imbedding $\frac{3}{4}$ inch square steel bars in blocks, of concrete 3 feet and 8 inches square. The bars projected 6 inches beyond the end of the concrete. Holes $\frac{1}{4}$ inch deep were drilled into the bars at regular distances apart, and corresponding holes made in the concrete. Two specimens of each mixture were made under the same conditions as the other specimens. Two specimens at a time were placed with the projecting bars in the doorway of the furnace, the concrete being of such size that it completely filled the openings. Thermo-couples were inserted in the holes in the bars nearest the fire, and thermometers in the others. The temperature of the furnace was raised and the temperature in each hole was read. Prof. Woolson found that when the end face of the concrete was subjected to a temperature of 1,700° F. for an hour, a point in the bar two inches from the heated face of the concrete has a temperature of only 1,000° F. a point five inches in the concrete only 400° to 500°, a point

eight inches in, only reached the temperature of boiling water and that the travel of heat along the bar was really very small.

Besides the above two, there still remain another experiments to be described on the conductivity of concrete. These however, were made in a similar way to determine the effect of various aggregates and hence are omitted here.

3. TEST SPECIMENS AND HEATING APPARATUS.

Concretes of different proportions, 1 : 1½ : 3, 1 : 2 : 4, 1 : 3 : 6, and 1 : 4 : 8 were used for testing. Two specimens of each kind were made. Each specimen was made in the form of a rectangular block, the front face to which heat was to be applied being molded in such a form to make it just fit the entrance opening of an electric furnace. The block was provided with six holes of 0.5 cm. diameter running in 6 cm. and 9 cm. depths from the upper face and being located at various distances from 6 cm. to 26 cm. from the front face.

An electric muffle furnace was used for heating the specimen on one side (front face) and a pyrometer with a platinum-rhodium thermocouple was used for the purpose of measuring the interior temperature of the furnace and the concrete. The pyrometer was carefully checked before the tests and corrected. Fig. 8 shows the size and the form of the test block, and also the location of the holes in which the thermocouple was inserted.

For the concrete Kidzu river sand and Kamo river gravel were used. The concrete was mixed moderately wet and well tamped. Each specimen was left for the first three days covered with a wet cloth, after which it was unmolded and stored in wet sand during 25 days and then tested.

4. TESTINGS.

Each specimens at the age of 28 days was placed for testing in the furnace doorway tightly to make it fit the opening, and an asbestos sheet

was packed around the opening to prevent the escape of heat. After such precautions, had been taken, the furnace temperature was raised from room temperature to 100° C. at first and keeping it constant for about half an hour in order to allow the transmission of heat freely through the concrete mass, the interior temperature was measured in every hole of the block by inserting the thermo-couple in it. Next, raising the furnace temperature up to 200° C. it was kept constant for about half an hour also and the interior temperature measured again. This process was repeated up to the furnace temperature of 900° C. raising 100° C. each time. The furnace temperature being raised at the rate of 100° about every half-hour, the temperature gradient in the testing made a sort of step form, and it took about 7 or 8 hours for the completion of the testing of each specimen. Two specimens for each concrete were tested and the mean value was taken from two measured temperatures in every hole.

In such a way the rate of heat conduction of the several concretes of varied proportions may be indicated by the difference of the measured temperatures in every hole of the concrete exposed to any definite temperature in the furnace.

5. RESULTS OF TESTS.

Tables XII—XV show the results obtained in the testing, and Figs. 9 a. b. c. are the curve sheets for these results. Each curve shows the variation of the temperature at several points of different distances from the heated surface in the concrete at which the readings were taken.

It will be seen that each curve has a steeper slope at the part nearer the heated surface and the higher the heating temperature the steeper the curve. At the part 10 cm. or more distant from the heating surface each curve becomes very flat.

Several proportions of the concrete ordinarily used, such as 1 : 1.5 : 3, 1 : 2 : 4 and 1 : 3 : 6 have no remarkable effect on thermal conductivity; a leaner mixture, such as 1 : 4 : 8, however, has less conductivity than the others,

The conclusions we may draw from this data are: That all gravel

Table XII.

Proportion 1 : 1.5 : 3.

Specimen	Temp. in furnace (C.)	Time elapsed in		Temperature in concrete at various distances from exposed surface (C.)					
		h	m	6	10	14	18	22	26(cm.)
a	6.0	0	0	6.0	6.0	6.0	6.0	6.0	6.0
b	11.0	0	0	11.0	11.0	11.0	11.0	11.0	11.0
mean	8.5	0	0	8.5	8.5	8.5	8.5	8.5	8.5
a	100.0		40	20.0	10.0	8.0	6.0	6.0	6.0
b	100.0		40	23.0	20.0	15.0	11.0	11.0	11.0
mean	100.0		40	21.5	15.0	11.5	8.5	8.5	8.5
a	200.0	1	30	42.0	28.0	20.0	9.0	6.0	6.0
b	200.0	1	30	40.0	25.0	20.0	15.0	11.0	11.0
mean	200.0	1	30	41.0	26.5	20.0	12.0	8.6	8.5
a	300.0	2	20	97.0	54.0	30.0	20.0	15.0	10.0
b	300.0	2	20	97.0	50.0	30.0	23.0	21.0	20.0
mean	300.0	2	20	97.0	52.0	30.0	21.0	18.0	15.0
a	400.0	3	10	100.0	90.0	54.0	30.0	25.0	20.0
b	400.0	3	10	99.0	80.0	50.0	28.0	23.0	20.0
mean	400.0	3	10	99.6	85.0	52.0	29.0	24.0	20.0
a	500.0	4	00	112.0	94.0	60.0	38.0	25.0	20.0
b	500.0	4	00	114.0	95.0	57.0	36.0	24.0	23.0
mean	500.0	4	00	113.0	94.5	58.5	37.0	24.5	21.5
a	600.0	4	50	115.0	97.0	76.0	48.0	34.0	25.0
b	600.0	4	50	120.0	98.0	73.0	45.0	34.0	25.0
mean	600.0	4	50	117.5	97.5	74.5	46.5	34.0	25.0
a	700.0	6	30	180.0	100.0	92.0	54.0	38.0	30.0
b	700.0	5	30	179.0	100.0	91.0	57.9	37.0	30.0
mean	700.0	6	40	179.5	100.0	91.5	55.5	37.5	30.0
a	800.0	7	30	208.0	102.0	95.0	62.0	43.0	34.0
b	800.0	6	30	210.0	104.0	95.0	60.0	43.0	34.0
mean	800.0	7	00	209.0	103.0	95.0	61.0	43.0	34.0
a	900.0	8	20	322.0	137.0	100.0	77.0	54.0	38.0
b	900.0	7	20	324.0	152.0	100.0	76.0	53.0	38.0
mean	900.0	7	50	323.0	144.5	100.0	76.5	53.5	38.0

Table XIII.

Proportion 1 : 2 : 4.

Specimen	Temp. in furnace (C.)	Time elapsed in		Temperature in concrete at various distances from exposed surface (C.)					
		h	m	6	01	14	18	22	26(cm.)
a	6.5	0	0	6.5	6.5	6.5	6.5	6.5	6.5
b	8.0	0	0	8.0	8.0	8.0	8.0	8.0	8.0
mean	7.25	0	0	7.25	7.25	7.25	7.25	7.25	7.25
a	100.0		50	15.0	9.0	6.5	6.5	6.5	6.5
b	100.0		55	15.0	13.0	8.0	8.0	8.0	8.0
mean	100.0		52.5	15.0	11.0	7.25	7.25	7.25	7.25
a	200.0	1	30	30.0	21.0	10.0	6.0	6.5	6.5
b	200.0	1	40	43.0	25.0	13.0	8.0	8.0	8.0
mean	200.0	1	35	36.5	23.0	11.5	7.25	7.25	7.25
a	300.0	2	10	90.0	04.8	30.0	10.0	6.5	6.5
b	300.0	2	00	90.0	43.0	30.0	25.0	15.0	15.5
mean	300.0	2	05	90.0	45.5	30.0	17.5	10.75	10.75
a	400.0	2	50	101.0	60.0	38.0	25.0	13.0	10.0
b	400.0	4	05	103.0	77.0	48.0	35.0	25.0	20.0
mean	400.0	3	28	102.0	68.5	43.0	30.0	19.0	15.0
a	500.0	3	30	108.0	68.0	43.0	30.0	25.0	12.0
b	500.0	4	45	117.0	94.0	70.0	43.0	30.0	25.0
mean	500.0	4	08	112.5	81.0	56.5	36.5	27.5	18.5
a	600.0	4	10	133.0	91.0	48.0	35.0	28.0	20.0
b	600.0	5	25	170.0	100.0	90.0	53.0	38.0	32.0
mean	600.0	4	48	151.0	95.5	69.0	44.0	33.0	26.0
a	700.0	4	50	167.0	96.0	57.0	38.0	30.0	28.0
b	700.0	6	05	208.0	108.0	96.0	60.0	43.0	34.0
mean	700.0	5	28	187.5	102.0	76.5	49.0	36.5	31.0
a	800.0	5	30	220.0	103.0	90.0	43.0	34.0	30.0
b	800.0	6	50	260.0	116.0	97.0	70.0	48.0	38.0
mean	800.0	6	10	240.0	109.5	93.6	56.5	41.0	34.0
a	900.0	6	10	390.6	120.0	100.0	60.0	40.0	37.0
b	900.0	7	35	332.0	137.0	103.0	92.0	60.0	43.0
mean	900.0	6	53	346.0	128.5	101.5	76.0	50.0	40.0

Table XIV.

Proportion 1 : 3 : 6.

Specimen	Temp. in furnace (C.)	Time elapsed in		Temperature in concrete at various distances from exposed surface (C.)					
		h	m	6	10	14	18	22	26(cm.)
a	8.5	0	0	8.5	8.5	8.5	8.5	8.5	8.5
b	9.0	0	0	9.0	9.0	9.0	9.0	9.0	9.0
mean	8.75	0	0	8.75	8.75	8.75	8.75	8.75	8.75
a	100.0		40	15.0	13.0	8.5	8.5	8.5	8.5
b	100.0		40	20.0	15.0	9.0	9.0	9.0	9.0
mean	100.0		40	17.5	14.0	8.75	8.75	8.75	8.75
a	200.0	1	20	30.0	23.0	12.0	8.5	8.5	8.5
b	200.0	1	20	34.0	26.0	15.0	9.0	9.0	9.0
mean	200.0	1	20	32.0	24.5	13.5	8.75	8.75	8.75
a	300.0	2	05	50.0	30.0	20.0	14.0	8.5	8.5
b	300.0	2	25	60.0	32.0	20.0	15.0	9.0	9.0
mean	300.0	2	15	55.0	31.0	20.0	14.5	8.75	3.75
a	400.0	2	50	97.0	54.0	30.0	20.0	12.0	12.0
b	400.0	2	50	100.0	60.0	34.0	25.0	20.0	15.0
mean	400.0	2	50	98.5	57.0	32.0	22.5	16.0	13.5
a	500.0	3	40	102.0	77.0	43.0	30.0	20.0	16.0
b	500.0	3	40	107.0	91.0	50.0	38.0	30.0	25.0
mean	500.0	3	40	104.5	84.0	46.5	34.0	25.0	20.5
a	600.0	4	30	127.0	95.0	60.0	32.0	23.0	21.0
b	600.0	4	35	164.0	103.0	76.0	45.0	38.0	30.0
mean	600.0	4	33	145.5	99.0	68.0	38.5	30.5	25.5
a	700.0	5	20	180.0	99.0	90.0	38.0	30.0	25.0
b	700.0	5	30	222.0	108.0	92.0	60.0	45.0	34.0
mean	700.0	5	25	201.0	103.5	91.0	49.0	37.5	29.5
a	800.0	6	20	242.0	108.0	94.0	53.0	38.0	30.0
b	800.0	6	20	268.0	122.0	97.0	77.0	57.0	38.0
mean	800.0	6	20	255.0	115.0	95.5	65.0	47.5	34.5
a	600.0	7	20	298.0	125.0	97.0	68.0	43.0	38.0
b	900.0	7	20	320.0	153.0	107.0	93.0	68.0	41.0
mean	900.0	7	20	309.0	139.0	102.0	80.5	55.5	39.5

Table XV.

Proportion 1 : 4 : 8.

Specimen	Temp. in furnace (C.)	Time elapsed in		Temperature in concrete at various distances from exposed surface (C.)					
		h	m	6	10	14	18	22	26(cm.)
a	8.0	0	0	8.0	8.0	8.0	8.0	8.0	8.0
b	5.0	0	0	5.0	5.0	5.0	5.0	5.0	5.0
mean	6.5	0	0	6.5	6.5	6.5	6.5	6.5	6.5
a	100.0		40	9.0	8.0	8.0	3.6	8.0	8.0
b	100.0		40	9.0	7.0	5.0	5.0	5.0	5.0
mean	100.0		40	9.0	7.5	6.5	6.5	6.5	6.5
a	200.0	1	30	30.0	25.0	20.0	10.0	8.0	8.0
b	200.0	1	30	28.0	23.0	12.0	9.0	5.0	5.0
mean	200.0	1	30	29.0	24.0	16.0	9.5	6.5	6.5
a	300.0	2	20	57.0	30.0	25.0	15.0	10.0	8.0
b	300.0	2	20	53.0	28.0	29.0	10.0	9.0	7.0
mean	300.0	2	20	55.0	29.0	22.5	12.5	9.5	7.5
a	400.0	3	10	90.0	43.0	29.0	24.0	15.0	10.0
b	400.0	3	00	96.0	43.0	34.0	20.0	12.0	10.0
mean	400.0	3	05	93.0	43.0	31.5	22.0	13.5	10.0
a	500.0	4	00	99.0	65.0	36.0	30.0	23.0	12.0
b	500.0	3	45	99.0	68.0	43.0	30.0	23.0	17.0
mean	500.0	3	53	99.0	66.5	39.5	30.0	23.0	14.5
a	600.0	4	50	108.0	80.0	39.0	35.0	29.0	20.0
b	600.0	4	30	120.0	96.0	60.0	38.0	25.0	20.0
mean	600.0	4	40	114.0	88.0	49.5	36.5	27.0	20.0
a	700.0	5	40	126.0	92.0	48.0	41.0	33.0	25.0
b	700.0	5	40	177.0	99.0	74.0	48.0	38.0	25.0
mean	700.0	5	40	151.5	95.5	61.0	44.5	35.5	25.0
a	800.0	6	35	163.0	94.0	60.0	48.0	38.0	30.0
b	800.0	6	40	218.0	99.0	93.0	55.0	40.0	30.0
mean	800.0	6	38	190.5	96.5	76.5	51.5	39.0	30.0
a	900.0	7	20	264.0	106.0	90.0	54.0	43.0	37.0
b	900.0	7	20	276.0	112.0	96.0	65.0	48.0	38.0
mean	900.0	7	20	270.0	109.0	93.0	59.5	45.5	37.5

concretes have a low thermal conductivity in general and the higher the surface temperature the lower comparatively the interior temperature, and herein lies their ability to resist fire. That the conduction of heat is not uniform through the concrete mass, being greater at the part near to the heating surface. That when the surface of a mass of the concrete is exposed for hours to a high heat, the temperature of the concrete 6 cm. beneath the surface will be several hundred degrees below the outside and a point 14 cm. beneath the surface would scarcely be heated above the boiling point of water. That a point 26 cm. beneath the surface would stand an outside temperature of 900° C. for half an hour with a rise of only from 37 to 43° C.. That as a result of such low thermal conductivity, 6 cm. or more of concrete covering will protect reinforcing metal from injurious heat (about 650° C. or more) for the period of any ordinary conflagration since the heating of the reinforcing steel up to almost 300° or 400° C. does not affect its physical properties.

6. EMPIRICAL FORMULA SHOWING THE RATE OF HEAT TRANSMISSION THROUGH THE CONCRETE MASS.

From the results obtained in the testing, the author intended boldly to deduce an empirical formula showing the rate of heat transmission through the concrete mass. The rate is not uniform, depending principally on the temperature at the exposed surface. Considering a definite temperature at the exposed surface the present writer assumed that the rate of heat transmission might be expressed by the following equation

$$y = \frac{\alpha}{\beta + x} + \gamma,$$

in which y stands for the temperature in the concrete mass, x the distance from the exposed surface, and α , β , and γ are the constants to be determined empirically in a given concrete.

The observations furnish the values of y for the given values of x and taking the greatest value of 900° C. as a definite temperature at the exposed surface, the most probable values of the constants α , β and γ were

determined for various proportions of concrete, by the ordinary method of least squares. Then we have,

- for 1 : 1.5 : 3, $a=3120.51$, $\beta=3.10$, $\gamma=-71.78$,
- for 1 : 2 : 4, $a=2975.95$, $\beta=2.88$, $\gamma=-67.27$,
- for 1 : 3 : 6, $a=3912.89$, $\beta=2.94$, $\gamma=-62.14$,
- for 1 : 4 : 8, $a=2206.78$, $\beta=2.25$, $\gamma=-44.51$

Thus an empirical formula is obtained for each concrete. Tables XVI—XIX show a comparison of the observed values of temperature in the concrete mass at various distances from the exposed surface with those computed from the empirical formula. The curves corresponding to the empirical formula and the actual observation are shown in Figs. 10—13. The agreement between the calculated and the observed values in each concrete is moderately close.

As the proof that the general formula is applicable for any definite temperature at the exposed surface of the concrete, an example taking 500° C. as the definite temperature in 1 : 2 : 4 concrete is added below. In this case the constants being determined in a similar way we have the following values,

$$a=1235.95, \quad \beta=2.37, \quad \gamma=-23.61$$

As Table XX and Fig. 14 show, the agreement between the calculated and the observed values is quite close.

Table XVI.

$$1 : 1.5 : 3. \quad y = \frac{3120.51}{3.10 + x} - 71.78$$

<i>x</i> in cm.	<i>y</i> in degrees C.		
	Observed	Calculated	Difference
0	900.00	943.84	+ 34.84
6	323.00	271.13	- 51.87
10	144.50	166.43	+ 21.93
14	100.00	110.71	+ 10.71
18	76.50	76.11	- 0.39
22	53.50	52.55	- 0.95
26	38.00	35.45	- 2.55

Table XVII.

1 : 2 : 4.

$$y = \frac{2975.95}{2.88 + x} - 67.28.$$

x in cm.	y in degrees C.		
	Observed	Calculated	Difference
0	900.00	966.05	+66.05
6	346.00	267.86	-78.14
10	128.50	163.78	+25.28
14	101.50	109.03	+7.53
18	76.00	75.26	-0.74
22	50.00	52.34	+2.34
26	40.00	35.78	-4.22

Table XVIII.

1 : 3 : 6.

$$y = \frac{2912.89}{2.94 + x} - 62.14.$$

x in cm.	y in degrees C.		
	Observed	Calculated	Difference
0	900.00	928.64	+28.64
6	309.00	263.81	-44.11
10	139.00	162.97	+23.97
14	102.00	109.81	+7.81
18	80.50	76.97	-3.53
22	55.00	54.66	-0.34
26	39.50	38.51	-0.91

Table XIX.

1 : 4 : 8.

$$y = \frac{2206.78}{2.25 + x} - 44.51.$$

x in cm.	y in degrees C.		
	Observed	Calculated	Difference
0	900.00	936.73	+36.73
6	270.00	222.98	-47.02
10	109.00	135.63	+26.63
14	93.00	91.29	-1.71
18	59.50	64.47	+4.97
22	45.50	46.50	+1.00
26	37.50	33.61	-3.89

Table XX.

1 : 2 : 4.

$$y = \frac{1235.95}{2.37 + x} - 23.61.$$

x in cm.	y in degrees C.		
	Observed	Calculated	Difference
0	500.00	497.90	-2.10
6	112.50	127.05	+11.55
10	81.00	76.31	-4.69
14	56.50	51.89	-4.61
18	36.50	37.07	+0.57
22	27.50	27.11	-0.39
26	18.50	19.96	+1.46

Thus we know that the rate of heat transmission through the concrete mass may be expressed approximately by the equation

$$y = \frac{a}{\beta + x} + \gamma,$$

in which the constants depend on the proportions of the concrete and the temperature at the exposed surface.

In a calculation of the deformation due to temperature in the concrete structure, it is usual to assume that the structure will be subjected to uniform temperature, and that means that the thermal stress in the concrete section produced by the temperature change is uniform throughout the section. But as mentioned above the temperature in the concrete section is not uniform at every point, decreasing greatly the further from the exposed surface, hence the thermal stress evidently varies. The deformation of the concrete caused by the temperature change in ordinary atmospheric conditions should be considerably less than that generally believed. If any reinforcement is used to prevent the temperature crack it would be more efficacious to insert it as near as possible to the exposed surface since that part is more deformed than the interior. The stress produced actually in the reinforcement due to thermal change should be considerably less than that calculated from the usual formula based on the temperature being

uniform through the whole mass, the error however, is always on the safe side.

CHAPTAR 3. EFFECTS OF TEMPERATURE AND HUMIDITY UPON THE TIME OF SET IN CEMENT.

I. GENERAL REMARKS

The setting of cement is due to chemical reaction, and the temperature is known to control the rate of all chemical reactions. In general, heat accelerates and cold retards chemical union. Furthermore, the solution of some products, such as gypsum ($Ca SO_4$), contained in Portland cement, is active at a relatively low temperature, and inactive at a higher temperature, which the solution of other products acts in the reverse order.

It is well known that the higher temperature accelerates and the lower temperature retards the time of set in cement. In our governmental regulations regarding Portland cement, it is specified that the beginning (initial set) and the end (final set) of setting must lie within proper limits of time. The standard temperature, however, is left out of consideration in the regulation curiously enough, although it is customary to test the time of set at the laboratory temperature of 15° — 18° C.

It is believed also that the humidity of the atmosphere has some effect on the set of cement, although no corrected data have yet been given on this factor. On the testing of set in cement either Vicat's or Gillmore's needle apparatus is commonly used, and the time of set is indicated by the penetration of the needle. Humidity specially would have more effect upon the results of such needle methods of determining the time of set, as these tests are made on the surface rather than on the body of the test specimen.

2. FORMULAE SHOWING THE EFFECT OF TEMPERATURE ON THE SETTING OF CEMENT.

Very few experiments on this subject have been carried out. The

most elaborate of which the author knows were those performed by Dr. S. Kasai⁽⁸⁾ at Berlin in 1905—1906. By his experiments he has determined the relations between the time of set in cement and the temperature and the humidity. These experiments were performed at ordinary atmospheric condition at various temperatures and humidities, without using any special regulating appliances, except that a wet cloth was placed around the specimen to obtain higher humidity.

The formula showing the velocity of chemical reaction is expressed in the following form ;

$$\log \frac{I}{z} = -\frac{a}{273+t} + \beta$$

where z , the time chemical reaction takes.
 t , the temperature of the atmosphere in degrees C.,
 a and β , the constants to be determined experimentally.

Since the setting of cement is due to chemical reaction, he investigated whether such a relation between the time of set in cement and the temperature might exist or not, and finally he proved by his experiments that the hypothesis was correct.

The formula for the setting of cement takes the following form ;
 for time of initial at (beginning of set),

$$\log_{10} \frac{I}{z_a} = -\frac{a}{273+t} + \beta_a$$

for time of final set (end of set),

$$\log_{10} \frac{I}{z_e} = -\frac{a}{273+t} + \beta_e$$

where z_a , the time of initial set,
 z_e , the time of final set,
 t , the temperature of the atmosphere in degrees C.,
 a, β_a, β_e , the constants varying with the kinds, condition in storage and degree of aeration of cement.

(8) Das Abbinden der Portlandzement von Dr. S. Kasai, Onoda (Japan) 1908.

He has also determined the following values of the constants for three kinds of cement used ;

for cement A	$\alpha=3470,$	$\beta_a=11,294,$	$\beta_e=11,066$
for cement B	$\alpha=2550,$	$\beta_a=7,935,$	$\beta_e=7,748$
for cement C	$\alpha=3760,$	$\beta_a=12,309,$	$\beta_e=12,157$

He concluded also from his investigations in the experimental results that the humidity does not have any considerable effect on the time of set in cement.

Prof. J. B. Johnson states in his own book⁽⁹⁾, with the results of Prof. Tetmajer's experiments as the basis, that usually the setting of cement progresses rapidly after it has begun as indicated by the curves in Fig. 14 and any cement sets very much more slowly at a low temperature than at a high temperature as is shown in Fig. 15, the relation for 1:3 Portland cement mortar being expressed by the following equations ;

$$\text{for time of initial set, } t = \frac{90.0}{4.0 + C^\circ} - 1.5 \text{ in hour}$$

$$\text{for time of final set, } t = \frac{244.7}{6.1 + C^\circ} - 1.8 \text{ in hour}$$

The author thought that a good deal of research still remained to be done on these subjects, and not content with the experiments described above, he has carried out tests on Portland cement with or without the various kinds of admixtures to determine their effect on the setting at same time, using special appliances to keep the temperature and the humidity constant at any required degree.

3. EQUIPMENT AND APPARATUS.

Although Dr. Kasai's experiment may be regarded as most valuable on this subject, it was restricted with in comparative narrow ranges of temperature and humidity since he carried it out in ordinary atmospheric conditions. The experiment made by the author covered wider ranges, he

(9) J. B. Johnson *The Materials of Construction*, 1914.

being provided with a special equipment and apparatus in order to being the test specimen subject either to required uniform temperature or humidity.

Figs. 16 a—d show the general view and the detailed part of the equipment. A wooden box (test box) is placed on the table, a thermostat and a humidstat being suspended in the box-chamber. The thermostat serves to keep the temperature and the humidstat, the humidity in the chamber at constant value. The former can be regulated by adjusting a screw at any required degree of temperature up to 130° F. and by the thermometer attached to it the chamber temperature can be read. The latter can be regulated also by its adjusting screw at any required percentage of humidity; it, however, can not indicate chamber humidity directly and hence it is necessary to use a hygrometer at the same time for that purpose. Both thermostat and humidstat are actuated automatically by electric means, and these instruments were manufactured by the Johnson Service Co. U. S. A. When the temperature or the humidity in the chamber exceeds the adjusted value the electric circuit breaks and after that when it reaches the adjusted value, the circuit being closed automatically, it starts anew.

To raise the temperature in the chamber to any required degree, the electric heaters six in number are fixed on the bottom of the box over which the metal gauze is spread over the whole surface in order to warm the chamber uniformly. The heaters are connected electrically with the thermostat.

To give the moisture in the chamber at any required percentage of humidity, an evaporator is attached near the lower side of the box. It consists of a can containing the water which is supplied from a small tank fastened outside the box and an electric heater. The water in the can may be heated and vaporized by the heater and the vapor enters into the chamber from two openings on the bottom passing through the connecting pipe. The evaporator is also connected electrically with the humidstat.

The thermostat works within a range of about 5° F. and the humidstat, of about 10 percent.

In such a way we can regulate the temperature and the humidity in

the chamber at any required value which is higher than that of the atmosphere. But it is impossible to maintain the temperature lower than the atmospheric temperature, as there is no cooling device provided. The effect of low temperature near or below freezing point being put out of consideration here, the testing was always carried out at a temperature higher than that of the atmosphere, and an intensely cold day in winter was chosen for the less required value.

In the testing for the less value of humidity than that in the atmosphere, calcium chloride was used to make it absorb the moisture in the chamber and to lower the humidity down to the required value. It was carefully endeavoured to keep the humidity constantly at that point, specially at the higher required temperature, since much moisture should be generated from the specimens placed in the chamber.

4. TESTING.

The testing was performed in two different ways. The first, the humidity in the chamber, being kept at a constant percentage, the time of set of the test specimen was measured at different uniform temperatures. The second, the temperature in the chamber being kept at a constant degree, the time of set was measured at different uniform humidities.

The variations of atmospheric temperature and humidity in Kyoto, obtained from the results observed during 43 years up to 1922 at the Kyoto Meteorological Station are shown in Fig. 17 a—b. The maximum temperature is about 38° C., the minimum about —8° C., the average 13.° 8 C. The maximum value of humidity is evidently 100%, the minimum about 10%, the average 77.2%.

In this testing, the humidity of 80% was taken as a standard value and as it was almost impossible to make the humidity as low as the minimum value in the time of testing with the equipment provided by the author, the range of humidity had to be restricted to between only 40 and 100%. As a standard temperature the ordinary value of 18° C. was used and the range of temperature was taken from 5° to 50° C., the lower value was neglected by insufficient equipment also.

Materials used for the testing were ;

- i neat Portland cement ("cement paste")
- ii Portland cement mixed with hydrated lime, the proportions being 0.7
c : 0.3 l ("lime paste")
- iii Portland cement mixed with volcanic ash, the proportions being 0.7
c : 0.3 a ("ash paste")
- iv Portland cement mixed with infusorial earth, the proportions being 0.7
c : 0.3 e ("earth paste")

The mixing of the materials was made in the laboratory on the cold days of last winter, and sometimes the water used for the mixing was warmed to a little lower than the required temperature in which the testing was carried out, in order to reduce its intense coldness by adding hot water to it. After each paste had been made, it was immediately placed in the chamber of the test box, whose temperature was regulated already and then were measured the times of set of the paste, both initial and final, by means of Vicat's needle apparatus.

In the first testing, the uniform temperatures were taken at every 5 degrees from 5° to 50° C. under the constant standard humidity of 80%. In the second testing, the uniform humidities were taken at every twenty percent from 40 to 100%, at the constant standard temperature of 18° C.

5. RESULTS OF TESTS

A. First Testing.

Table XXI shows the results obtained in the testing, and Fig. 18 is a curve sheet showing the variation in time of set of cement and other pastes with relation to different temperatures. Each curve shows evidently that the temperature has a remarkable effect on the time of set. As is generally recognized, the lower temperature retards and the higher temperature accelerates the times of set, both initial and final. The rate of variation is not uniform, being greater with the lower temperatures.

Table XXI.

Kind of paste	Temperature (C) in		Amount of water (%)	Time of set (h, m)				Duration
	labor.	water		Init.	Fin.	Mean		
						Init.	Fin.	
Temperature 5° C.								
Cement	2.5—8.0	5.0	26.2	6.06	19.11			
"	"	"	"	6.01	19.10	6.04	19.11	13.07
Lime	"	"	40.0	8.08	26.29			
"	"	"	"	8.09	26.26	8.09	26.28	18.19
Ash	"	"	32.0	7.09	28.40			
"	"	"	"	7.06	28.48	7.08	28.44	21.36
Earth	"	"	72.0	9.16	30.17			
"	"	"	"	9.18	30.25	9.17	30.21	21.04
Temperature 10° C.								
Cement	2.5—7.5	6.7	26.2	5.03	15.56			
"	"	"	"	5.02	15.55	5.03	15.56	10.53
Lime	"	"	40.0	6.03	21.03			
"	"	"	"	6.05	21.06	6.04	21.05	15.01
Ash	"	"	32.0	4.58	21.13			
"	"	"	"	4.56	21.16	4.57	21.15	16.18
Earth	"	"	72.0	6.06	22.29			
"	"	"	"	6.10	22.31	6.08	22.30	16.22
Temperature 15° C.								
Cement	3.5—8.0	7.0	26.2	4.11	12.51			
"	"	"	"	4.24	12.58	4.18	12.55	8.37
Lime	"	"	40.0	5.29	16.05			
"	"	"	"	5.34	16.16	5.32	16.11	10.39
Ash	"	"	32.0	3.58	19.50			
"	"	"	"	4.12	20.10	4.05	20.00	15.55
Earth	"	"	72.0	5.38	18.20			
"	"	"	"	5.43	18.30	5.41	18.25	12.44
Temperature 20° C.								
Cement	6.5—8.5	5.0	26.2	3.45	8.57			
"	"	"	"	3.49	8.56	3.47	8.57	5.10
Lime	"	"	40.0	4.07	10.15			
"	"	"	"	4.17	10.29	4.11	10.27	6.16
Ash	"	"	32.0	3.46	16.18			
"	"	"	"	3.44	16.15	3.45	16.17	12.32
Earth	"	"	72.0	4.20	12.42			
"	"	"	"	4.24	12.48	4.22	12.45	8.23

Kind of paste	Temperature (C) in		Amount of water (%)	Time of set (h, m)				Duration
	labor.	water		Init.	Fin.	Mean		
						Init.	Fin.	
Temperature 25° C.								
Cement	8.0—12.0	7.0	26.2	2.19	7.08			
"	"	"	"	2.29	7.07	2.24	7.08	4.44
Lime	"	"	40.0	2.55	8.15			
"	"	"	"	3.00	8.19	2.58	8.17	5.19
Ash	"	"	32.0	1.49	10.41			
"	"	"	"	1.52	10.40	1.51	10.41	8.50
Earth	"	"	72.0	3.13	11.18			
"	"	"	"	3.15	11.25	3.14	11.22	8.08
Temperature 30° C.								
Cement	5.0—7.5	6.0	26.2	2.05	5.50			
"	"	"	"	2.03	5.53	2.04	5.52	3.48
Lime	"	"	40.0	2.29	7.03			
"	"	"	"	3.00	6.50	2.45	6.57	4.12
Ash	"	"	32.0	1.38	8.40			
"	"	"	"	1.40	8.38	1.39	8.39	7.00
Earth	"	"	72.0	3.04	10.02			
"	"	"	"	3.10	10.00	3.07	10.01	6.54
Temperature 35° C.								
Cement	4.0—7.5	5.5	26.2	1.58	5.13			
"	"	"	"	1.52	5.09	1.55	5.11	3.16
Lime	"	"	40.0	2.19	6.02			
"	"	"	"	2.32	6.04	2.26	6.03	3.37
Ash	"	"	32.0	1.13	8.02			
"	"	"	"	1.21	8.04	1.17	8.03	6.46
Earth	"	"	72.0	2.28	9.26			
"	"	"	"	2.45	9.58	2.37	9.42	7.05
Temperature 40° C.								
Cement	5.0—8.0	5.0	26.2	1.50	4.05			
"	"	"	"	1.45	4.19	1.48	4.12	2.24
Lime	"	"	40.0	2.07	5.02			
"	"	"	"	1.55	5.00	2.01	5.01	3.00
Ash	"	"	32.0	1.12	6.05			
"	"	"	"	1.00	6.18	1.06	6.12	5.06
Earth	"	"	72.0	2.12	7.07			
"	"	"	"	2.30	7.27	2.21	7.17	4.56

Kind of paste	Temperature (C) in		Amount of water (%)	Time of set (h, m)				Duration
	labor.	water		Init.	Fin.	Mean		
						Init.	Fin.	
Temperature 45° C.								
Cement	7.0-9.0	6.0	26.2	1.32	3.54			
"	"	"	"	1.40	4.02	1.36	3.58	2.22
Lime	"	"	40.0	1.56	4.28			
"	"	"	"	2.02	4.48	1.59	4.38	2.39
Ash	"	"	32.0	0.54	5.23			
"	"	"	"	0.58	5.38	0.56	5.31	4.35
Earth	"	"	72.0	2.06	6.49			
"	"	"	"	2.11	6.58	2.09	6.54	4.45
Temperature 50° C.								
Cement	4.5-5.5	4.5	26.2	1.21	3.07			
"	"	"	"	1.22	3.17	1.22	3.12	1.50
Lime	"	"	40.0	1.37	3.17			
"	"	"	"	1.42	3.20	1.40	3.19	1.39
Ash	"	"	32.0	0.40	4.02			
"	"	"	"	0.45	4.09	0.43	4.05	3.23
Earth	"	"	72.0	1.44	5.36			
"	"	"	"	1.58	5.28	1.51	5.32	3.41

As mentioned already Dr. Kasai concluded from the results obtained in his experiments that the general formula showing the velocity of the chemical reaction is also applicable for the setting of cement and he adopted the following formulæ to express the relation between the time of set in cement and the atmospheric temperature ;

$$\text{for the time of initial set, } \log_{10} \frac{I}{z_a} = -\frac{\alpha}{273+t} + \beta_a,$$

$$\text{for the time of final set, } \log_{10} \frac{I}{z_e} = -\frac{\alpha}{273+t} + \beta_e.$$

Will the results of the author's experiments satisfy these relations too?

In the next place, the author will endeavour to prove whether that question can be answered in the affirmative or not in a way similar to that of Dr. Kasai.

$$\text{The formula, } \log \frac{I}{z} = -\frac{\alpha}{273+t} + \beta$$

may be written in the form, $y = -a x + \beta$

in which y stands for $\log \frac{1}{z}$ and x for $\frac{1}{273+t}$

This is an equation of a straight line and the constants a and β may be determined if the straight line is drawn from the calculated values of x and y , with the observed values of t and z as basis.

From the results obtained in the testing we obtained the observed and the calculated values as shown in Table XXII.

Plotting the points, taking x as abscissa and y as ordinate, we see that the points lay on nearly a straight line and the two lines for both the initial (beginning) and the final (end) set in each paste are nearly parallel.

Fig. 19 a—d show the parallel lines averaging the points plotted in each time of initial and of final set for four kinds of paste.

Values of the constant a and β can be easily determined from the nature of the straight line drawn for each paste. For cement paste (see Fig. 20),

$$a = \tan \theta = \frac{0.926}{0.003674 - 0.003100} = \frac{0.926}{0.000574} = 1604.17$$

$$\approx 1604.$$

$$0.000574 : 0.926 = 0.002805 : \beta_e$$

$$\beta_e = \frac{0.926 \times 0.002805}{0.000574} = 4.5251$$

$$\approx 4.525$$

$$\beta_a = \beta_e + 0.430 = 4.955$$

Thus we have ;

for cement paste, $\log_{10} \frac{1}{z_a} = -\frac{1604}{273+t} + 4.955$

$$\log_{10} \frac{1}{z_e} = -\frac{1604}{273+t} + 4.525$$

similarly,

for lime paste, $\log_{10} \frac{1}{z_a} = -\frac{1827}{273+t} + 5.585$

Table XXII.

Observed values.			Calculated values.					
t	z_a	z_e	$\frac{1}{z_a}$	$\frac{1}{z_e}$	$y = \log_{10} \frac{1}{z_a}$	$y = \log_{10} \frac{1}{z_e}$	$273 + t$	$x = \frac{1}{273 + t}$
A. CEMENT PASTE								
5	6.07	19.18	0.1647	0.0521	$\bar{1}.217$	$\bar{2}.717$	273	0.00360
10	5.05	15.93	0.1980	0.0628	$\bar{1}.297$	$\bar{2}.798$	283	0.00353
15	4.30	12.92	0.2326	0.0778	$\bar{1}.367$	$\bar{2}.889$	288	0.00347
20	3.78	8.95	0.2646	0.1117	$\bar{1}.423$	$\bar{1}.048$	293	0.00341
25	2.40	7.13	0.4167	0.1403	$\bar{1}.619$	$\bar{1}.147$	298	0.00336
30	2.07	5.87	0.4831	0.1704	$\bar{1}.684$	$\bar{1}.231$	303	0.00330
35	1.92	5.18	0.5208	0.1931	$\bar{1}.717$	$\bar{1}.286$	308	0.00325
40	1.80	4.20	0.5556	0.2381	$\bar{1}.745$	$\bar{1}.377$	313	0.00319
45	1.60	3.97	0.6250	0.2519	$\bar{1}.796$	$\bar{1}.401$	318	0.00314
50	1.37	3.20	0.7575	0.3125	$\bar{1}.879$	$\bar{1}.495$	323	0.00310
B. LIME PASTE								
5	8.15	26.47	0.1227	0.0378	$\bar{1}.089$	$\bar{2}.577$	278	0.00360
10	6.07	21.08	0.1647	0.0474	$\bar{1}.217$	$\bar{2}.676$	283	0.00353
15	5.53	16.18	0.1808	0.0618	$\bar{1}.257$	$\bar{2}.791$	288	0.00347
20	4.18	10.45	0.2392	0.0957	$\bar{1}.379$	$\bar{2}.933$	293	0.00341
25	2.97	8.28	0.3367	0.1208	$\bar{1}.527$	$\bar{1}.082$	298	0.00336
30	2.75	6.95	0.3636	0.1439	$\bar{1}.561$	$\bar{1}.158$	303	0.00330
35	2.43	6.05	0.4115	0.1653	$\bar{1}.614$	$\bar{1}.218$	308	0.00325
40	2.02	5.02	0.4950	0.1992	$\bar{1}.695$	$\bar{1}.299$	313	0.00319
45	1.98	4.63	0.5051	0.2160	$\bar{1}.703$	$\bar{1}.334$	318	0.00314
50	1.67	3.32	0.5988	0.3106	$\bar{1}.777$	$\bar{1}.492$	323	0.00310
C. ASH PASTE								
5	7.13	28.73	0.1403	0.0348	$\bar{1}.147$	$\bar{2}.542$	278	0.00360
10	4.95	21.25	0.2020	0.0471	$\bar{1}.305$	$\bar{2}.673$	283	0.00353
15	4.08	20.00	0.2451	0.0500	$\bar{1}.389$	$\bar{2}.699$	288	0.00347
20	3.75	16.28	0.2667	0.0614	$\bar{1}.426$	$\bar{2}.788$	293	0.00341
25	1.85	10.68	0.5405	0.0936	$\bar{1}.733$	$\bar{2}.971$	298	0.00336
30	1.65	8.65	0.6061	0.1156	$\bar{1}.783$	$\bar{1}.063$	303	0.00330
35	1.28	8.05	0.7813	0.1242	$\bar{1}.893$	$\bar{1}.094$	308	0.00325
40	1.10	6.20	0.9091	0.1613	$\bar{1}.959$	$\bar{1}.208$	313	0.00319
45	0.93	5.52	1.0753	0.1812	0.032	$\bar{1}.258$	318	0.00314
50	0.72	4.10	1.3890	0.2439	0.143	$\bar{1}.387$	323	0.00310
D. EARTH PASTE								
5	9.28	30.35	0.1073	0.0329	$\bar{1}.033$	$\bar{2}.517$	278	0.00360
10	6.13	22.50	0.1631	0.0437	$\bar{1}.212$	$\bar{2}.640$	283	0.00353
15	5.68	18.42	0.1761	0.0543	$\bar{1}.246$	$\bar{2}.735$	288	0.00347
20	4.37	12.75	0.2288	0.0784	$\bar{1}.359$	$\bar{2}.894$	293	0.00341
25	3.23	11.37	0.3096	0.0880	$\bar{1}.491$	$\bar{2}.944$	298	0.00336
30	3.12	10.02	0.3205	0.0998	$\bar{1}.506$	$\bar{2}.999$	303	0.00330
35	2.62	9.70	0.3817	0.1031	$\bar{1}.582$	$\bar{1}.013$	308	0.00325
40	2.35	7.28	0.4255	0.1374	$\bar{1}.629$	$\bar{1}.138$	313	0.00319
45	2.15	6.90	0.4651	0.1449	$\bar{1}.668$	$\bar{1}.161$	318	0.00314
50	1.85	5.53	0.5405	0.1808	$\bar{1}.733$	$\bar{1}.257$	323	0.00310

$$\log_{10} \frac{1}{z_e} = -\frac{1827}{273+t} + 5.153$$

for ash paste, $\log_{10} \frac{1}{z_a} = -\frac{1717}{273+t} + 5.414$

$$\log_{10} \frac{1}{z_e} = -\frac{1717}{273+t} + 4.694$$

for earth paste, $\log_{10} \frac{1}{z_a} = -\frac{1384}{273+t} + 4.062$

$$\log_{10} \frac{1}{z_e} = -\frac{1384}{273+t} + 3.550$$

Now we will see what is the difference between the values observed actually and those calculated from the formulæ.

The statement is shown in Table XXIII. Several curves plotted from observed and calculated values of z_a and z_e for each paste are shown in Fig. 21 a—d. The full line (broken) indicates the curve obtained from the observed values and the dotted line, that from the calculated values based on the formula of chemical reaction. In each case the calculated curve seems to be an average line of irregular observed curve and so both curves agree moderately well, the difference at any temperature being small.

Thus, it is proved that Dr. Kasai's conclusion of the relation between the time of set in cement and that atmospheric temperature is fairly correct, although his experiments were not carried out in a definite condition of humidity, and indirectly that the effect of humidity on time of set is not considerable. The author has proved that the formula showing the velocity of chemical reaction is applicable for the time of set, not only in cement but for all pastes containing any admixture of cement, only differing in the values of the constants, α and β , for each paste.

Furthermore, the author endeavoured to learn whether his experimental results agreed or not with those of Prof. Tetmajer's experiment, assuming the latter to be expressed by the following formula generally,

$$z = \frac{a}{b+t} + c,$$

Table XXIII.

Temperature in degrees C.	Observed, in hours	Calculated, in hours					
		Formula of chem. react.	Dif.	Tetmajer's formula	Dif.	Author's formula	Dif.
A. CEMENT PASTE							
Time of Initial set							
5	6.07	6.53	+0.46	7.18	+1.11	5.85	-0.22
10	5.05	5.15	+0.10	5.02	-0.03	5.02	-0.03
15	4.30	4.11	-0.19	3.85	-0.45	4.27	-0.03
20	3.78	3.30	-0.48	3.12	-0.66	3.60	-0.18
25	2.40	2.68	+0.28	2.62	+0.22	3.01	+0.61
30	2.07	2.18	+0.11	2.25	+0.18	2.50	+0.43
35	1.92	1.79	-0.13	1.97	+0.05	2.07	+0.15
40	1.80	1.48	-0.32	1.75	-0.05	1.72	-0.08
45	1.60	1.23	-0.37	1.57	-0.03	1.45	-0.15
50	1.37	1.03	-0.29	1.43	+0.06	1.26	-0.11
Time of Final set							
5	19.18	17.57	-1.61	21.24	+2.06	19.21	+0.03
10	15.93	13.87	-2.06	15.08	-0.85	15.58	-0.35
15	12.92	110.6	-1.86	11.46	-0.46	12.41	-0.51
20	8.95	8.89	-0.06	9.08	+0.13	9.72	+0.77
25	7.13	7.21	+0.08	7.39	+0.26	7.51	+0.38
30	5.87	5.88	+0.01	6.13	+0.26	5.77	-0.10
35	5.18	4.82	-0.36	5.16	-0.02	4.51	-0.67
40	4.20	3.98	-0.22	4.39	+0.19	3.72	-0.48
45	3.97	3.30	-0.67	3.75	-0.22	3.41	-0.56
50	3.20	2.78	-0.44	3.23	+0.03	3.57	+0.37
B. LIME PASTE							
Time of Initial set							
5	8.15	9.79	+1.64	8.76	+0.61	7.91	-0.24
10	6.07	7.48	+1.41	6.26	+0.19	6.49	+0.42
15	5.53	5.78	+0.25	4.83	-0.70	5.27	-0.26
20	4.18	4.51	+0.33	3.91	-0.27	4.23	+0.05
25	2.97	3.54	+0.57	3.26	+0.30	3.39	+0.42
30	2.75	2.81	+0.06	2.78	+0.03	2.73	-0.02
35	2.43	2.24	-0.19	2.42	-0.01	2.27	-0.16
40	2.02	1.80	-0.22	2.12	+0.01	1.99	-0.03
45	1.98	1.46	-0.52	1.89	-0.09	1.91	-0.07
50	1.67	1.19	-0.48	1.69	+0.02	2.01	+0.38
Time of Final set							
5	26.47	26.39	-0.08	29.16	+2.69	26.07	-0.40
10	21.08	20.12	-0.96	19.54	-1.54	20.69	-0.39
15	16.18	15.55	-0.63	14.33	-1.85	16.05	-0.13
20	10.45	12.14	+1.69	11.07	+0.62	12.16	+1.71
25	8.28	9.52	+1.24	8.84	+0.56	9.01	+0.73
30	6.95	7.55	+0.63	7.21	+0.26	6.61	-0.34
35	6.05	6.02	-0.03	5.97	-0.08	4.95	-1.10
40	5.02	4.84	-0.18	5.00	-0.02	4.04	-0.98
45	4.63	3.92	-0.71	4.21	-0.42	3.88	-0.75
50	3.22	3.19	-0.13	3.56	+0.24	4.45	+1.11

Temperature in degrees C.	Observed, in hours	Calculated, in hours					
		Formula of chem. react.	Dif.	Tetmajer's formula	Dif.	Author's formula	Dif.

C. ASH PASTE

Time of Initial set

5	7.13	5.78	-1.35	8.06	+0.93	6.55	-0.58
10	4.95	4.50	-0.45	5.21	+0.26	5.23	+0.28
15	4.08	3.53	-0.55	3.73	-0.35	4.09	+0.01
20	3.75	2.79	-0.96	2.81	-0.94	3.14	-0.61
25	1.85	2.23	+0.38	2.18	+0.33	2.37	+0.52
30	1.65	1.79	+0.14	1.72	+0.07	1.77	+0.12
35	1.28	1.45	+0.17	1.39	+0.11	1.39	+0.11
40	1.10	1.18	+0.08	1.13	+0.03	1.18	+0.08
45	0.93	0.97	+0.04	0.91	-0.02	1.15	+0.22
50	0.72	0.80	+0.08	0.73	+0.01	1.31	+0.59

Time of Final set

5	28.73	30.30	+1.57	31.02	+1.29	27.91	-0.82
10	21.25	23.58	+2.33	22.90	+1.75	23.08	+1.83
15	20.00	18.52	-1.48	17.40	-2.60	18.83	-1.17
20	16.28	14.66	-1.62	14.07	-2.21	15.12	-1.16
25	10.68	11.70	+1.02	11.40	+0.72	11.97	+1.31
30	8.65	9.40	+0.75	9.35	+0.70	9.37	+0.72
35	8.05	7.60	-0.45	7.72	-0.33	7.33	-0.72
40	6.20	6.20	0.00	6.41	+0.21	5.84	-0.36
45	5.52	5.07	-0.45	5.31	-0.21	4.91	-0.61
50	4.10	4.19	+0.09	4.40	+0.30	4.53	+0.43

D. EARTH PASTE

Time of Initial set

5	9.28	8.24	-1.04	8.89	-0.39	8.59	-0.69
10	6.13	6.73	+0.60	6.64	+0.51	7.02	+0.89
15	5.68	5.53	-0.15	5.25	-0.43	5.67	-0.01
20	4.37	4.59	+0.22	4.30	-0.07	4.54	+0.17
25	3.23	3.82	+0.59	3.61	+0.38	3.63	+0.40
30	3.12	3.21	+0.09	3.08	-0.04	2.94	-0.18
35	2.62	2.70	+0.08	2.67	+0.05	2.47	-0.15
40	2.35	2.29	-0.06	2.34	-0.01	2.22	-0.13
45	2.15	1.95	-0.20	2.07	-0.08	2.19	+0.04
50	1.85	1.67	-0.18	1.84	-0.01	2.38	+0.53

Time of Final set

5	30.35	26.81	-3.54	31.47	+1.12	28.69	-1.66
10	22.50	21.88	-0.62	22.39	-0.11	23.38	+0.88
15	18.42	18.02	-0.40	17.24	-1.18	18.79	+0.37
20	12.75	14.93	+2.18	13.92	+1.17	14.93	+2.18
25	11.37	12.42	+1.05	11.60	+0.23	11.79	+0.42
30	10.02	10.43	+0.41	9.89	-0.13	9.38	-0.64
35	9.70	8.79	-0.91	8.58	-1.12	7.69	-2.01
40	7.28	7.45	+0.17	7.54	+0.26	6.73	-0.55
45	6.90	6.34	-0.56	6.69	-0.21	6.49	-0.45
50	5.53	5.43	-0.10	5.99	+0.46	6.98	+1.45

in which z and t are the same as before and a , b and c are the constants depending on the kind of cement, admixture if used, and other conditions, which are to be determined experimentally.

By applying the method of least squares in order to determine the most probable values of the constants from the results obtained in the testing, we get:

i Cement paste,

for the time of initial set,

$$a=86.17, \quad b=6.86, \quad c=-0.09$$

$$z_a = \frac{86.17}{6.86+t} - 0.09$$

for the time of final set,

$$a=337.62, \quad b=9.24, \quad c=-2.47$$

$$z_e = \frac{337.62}{9.24+t} - 2.47$$

ii Lime paste,

for the time of initial set,

$$a=122.18, \quad b=8.32, \quad c=-0.40$$

$$z_a = \frac{122.18}{8.32+t} - 0.40$$

for the time of final set,

$$a=380.77, \quad b=6.77, \quad c=-3.14$$

$$z_e = \frac{380.77}{6.77+t} - 3.14$$

iii Ash paste,

for the time of initial set,

$$a=100.29, \quad b=6.00, \quad c=-1.06$$

$$z_a = \frac{100.29}{6.00+t} - 1.06$$

for the time of final set,

$$a=671.73, \quad b=13.03, \quad c=-6.26$$

$$z_e = \frac{671.73}{13.03+t} - 6.26$$

iv Earth paste,

for the time of initial set,

$$a=157.33, \quad b=11.27, \quad c=-0.72$$

$$z_a = \frac{157.33}{11.37 + t} - 0.72$$

for the time of final set,

$$a=432.09, \quad b=8.13, \quad c=-1.44$$

$$z_e = \frac{432.09}{8.13 + t} - 1.44$$

In the Table XXIII a comparison of the observed values of the time of set with those computed from these formulæ and in Fig. 21 a—d the curves corresponding to the formulæ (drawn in chain lines) are shown. The agreement between the calculated and the observed values in each case is moderately close.

Lastly, the author intended to propose a new formula to show the relation more correctly and simply. Assume the relation to be expressed by the equation,

$$z = a + bt + ct^2$$

the notations being the same as before. This is equivalent to assuming that the curve is a parabola, with its axis vertical.

The observations furnish the values of z for the values of t ; and thus, determining the values of the constants a , b and c , by the ordinary method of least squares, we have :

i Cement paste,

for the time of initial set,

$$a=6.76, \quad b=-0.19, \quad c=0.0016$$

$$z_a = 6.76 - 0.19t + 0.0016t^2$$

for the time of final set,

$$a=23.32, \quad b=-0.87, \quad c=0.0095$$

$$z_e = 23.32 - 0.87t + 0.0095t^2$$

ii Lime paste,

for the time of initial set,

$$a=9.51, \quad b=-0.34, \quad c=0.0038$$

$$z_a=9.51-0.34t+0.0038t^2$$

for the time of final set,

$$a=32.20, \quad b=-1.30, \quad c=0.0149$$

$$z_e=32.20-1.30t+0.0149t^2$$

iii Ash paste,

for the time of initial set

$$a=8.06, \quad b=-0.32, \quad c=0.0037$$

$$z_a=8.06-0.32t+0.0037t^2$$

for the time of final set,

$$a=33.28, \quad b=-1.13, \quad c=0.0111$$

$$z_e=33.28-1.13t+0.0111t^2$$

iv Earth paste,

for the time of initial set,

$$a=10.38, \quad b=-0.38, \quad c=0.0044$$

$$z_a=10.38-0.38t+0.0044t^2$$

for the time of final set,

$$a=34.73, \quad b=-1.28, \quad c=0.0145$$

$$z_e=34.73-1.28t+0.0145t^2$$

In Table XXIII a comparison of the observed values of the time of set with those computed from these formulæ and in Fig. 21 a—d the curves corresponding to the formulæ (drawn in double dotted chain lines) are shown. The agreement between the parabolic curve and the observed broken line in each case is moderately close.

Thus, there are three forms of the formulæ to show the relation between the atmospheric temperature and the time of set in cement either with or without any admixture and the calculated values from each of them has a close agreement with the values obtained from direct observation of same kind of paste respectively. Comparing these formulæ, the first form, the general formula of chemical reaction, is too tedious to apply directly and although the second form, Tetmajer's formula, is simpler, it is inferior to the third form, the author's formula, in close agreement with the observed results as a whole, the first being the most inferior in this point.

It is to be noticed here that according to the formula deduced by the author the highest temperature sometimes makes the time of set rather slower than that of a low temperature. It means the point corresponding to the highest temperature passes over the lowest point or vertex of the parabola, and of course this is irrational, although the agreement between the computed and the observed values is very close. Hence the author persists in maintaining that his formula is reasonably applicable in the temperature range from 5° to 45° C. excluding the highest temperatures.

In conclusion we would say that, it is very important to specify a standard temperature at the testing of setting time in Portland cement, a matter which is neglected in our governmental regulations, and in cases where admixtures are used, it is irrational to follow the regulation intended for cement only; and especially is it reasonable the time of final set, to specify a time later by 20—30% than that of cement, according to the kind of admixture used at 20° C.

B. Second Testing.

Table XXIV shows the results obtained in the testing and Fig. 22 is a curve sheet showing the variation of time of set in cement and other pastes with relation to difference in humidity. Each curve makes nearly a straight line and hence the variation is approximately uniform.

As a rule, the humidity has the effects retarding the times of set, both initial and final. The mean time of the initial set of cement paste is 3^h.06^m at 40%, and 3^h.55^m at 100% humidity; and the mean time of the final set of the same is 8^h.46^m at 40%, and 9^h.28^m at 100%, the retardation being 49^m for the former and 42^m for the latter. The retardation in other pastes within the same range of humidity is about 30^m for the initial and about from 1 to 1½^h for the final set. So, the effect of humidity on the time of set in any paste is not considerable. If we assume 80% as a normal humidity, the higher value tends to retard and the lower value, to accelerate the time of set generally.

Thus we may say that, although it is not necessary to specify a

Table XXIV.

Kind of paste	Temperature (C) in		Amount of water (%)	Time of see (h, m)				Duration (h, m)
	labor.	water		Init.	Fin.	Mean		
						Init.	Fin.	
Humidity 100%								
Cement	5.0—7.5	5.0	26.2	3.00	9.20			
"	"	"	"	4.00	9.36	3.55	9.28	5.33
Lime	"	"	40.0	4.48	12.03			
"	"	"	"	4.41	12.46	4.45	12.25	7.40
Ash	"	"	32.0	3.53	17.53			
"	"	"	"	4.03	18.05	3.58	17.59	14.01
Earth	"	"	72.0	4.58	14.38			
"	"	"	"	5.02	14.52	5.00	14.45	9.45
Humidity 80%								
Cement	6.0	4.5	26.2	3.35	9.18			
"	"	"	"	3.49	9.30	3.42	9.24	5.42
Lime	"	"	40.0	4.38	12.14			
"	"	"	"	4.30	11.46	4.34	12.00	7.26
Ash	"	"	32.0	3.25	17.01			
"	"	"	"	3.37	17.21	3.31	17.11	13.40
Earth	"	"	72.0	4.58	14.08			
"	"	"	"	4.46	14.00	4.52	14.04	9.12
Humidity 60%								
Cement	6.0—7.0	5.5	26.2	3.23	9.03			
"	"	"	"	3.26	9.10	3.25	9.07	5.42
Lime	"	"	40.0	4.20	11.40			
"	"	"	"	4.24	11.46	4.22	11.43	7.21
Ash	"	"	32.0	3.17	16.37			
"	"	"	"	3.22	16.43	3.19	16.40	13.21
Earth	"	"	72.0	4.40	13.24			
"	"	"	"	4.50	13.29	4.45	13.27	8.42
Humidity 40%								
Cement	5.0—8.0	5.0	26.2	3.00	8.45			
"	"	"	"	3.12	8.46	3.06	8.46	5.40
Lime	"	"	40.0	4.10	11.17			
"	"	"	"	4.16	11.31	4.13	11.24	7.11
Ash	"	"	32.0	3.12	16.18			
"	"	"	"	3.14	16.23	3.13	16.21	13.08
Earth	"	"	72.0	4.33	12.53			
"	"	"	"	4.40	13.03	4.37	12.58	8.21

standard humidity at testing the time of set in cement or any other paste as in the case of temperature, it should be put in consideration that the higher percentage of humidity has always a retarding effect.

C. Effect of Admixture.

For the relative effectiveness of the different admixtures on the time of set when compared with cement paste at varying temperatures, it will be seen from the results of the first testing that the hydrated lime and the infusorial earth act as retarders of the time of set in cement both initial and final, especially of the latter. The volcanic ash retards the time of final set also, but it accelerates the time of initial set at a higher temperature than 10° C. As a rule, the amount of retardation becomes greater with the lower temperature. The maximum retardation occurs always at the lowest temperature of 5° C. and its amount for the time of initial set is 2^h.05^m in lime paste, 3^h.13^m in earth paste, and 1^h.04^m in ash paste, and for the time of final set, 7^h.17^m, 11^h.10^m, and 9^h.33^m respectively. Of the all, the infusorial earth most retards the time of set, both initial and final, except that the volcanic ash affects mostly the time of final set within a narrow range near the standard temperature. The effect of retardation of the hydrated lime is less than that of the infusorial earth at any temperature. The volcanic ash retards the time of final set more than the hydrated lime, and curiously it accelerates the time of initial set at any temperature excepting the lowest, although the variation does not exceed an hour. For the duration of the setting, i. e., the time expended from beginning to end of setting, the cement paste has the least value and the lime paste follows it. Earth paste has less value than ash paste at low temperatures, but they have about the same value at higher temperatures.

For the effect of admixture on the time of set at varying degrees of humidity, it will be seen from the results of the second testing that any admixture in the cement acts as a retarder of the time of set, especially of final set in any condition of humidity. Average retardations of the time of final set for ash, earth and lime pastes are 7^h.50^m, 4^h.30^m and 2^h.40^m

respectively. Infusorial earth and hydrated lime retard the time of initial set, the average retardation being 1^h. 20^m and 1^h. 00^m respectively. Volcanic ash, however, does not have any considerable effect on the time of initial set. It accelerates rather the initial set when the humidity is higher than about 60%, but the variation is a matter of only a few minutes. For the duration of the setting, ash paste is the longest of all and earth and lime pastes follow.

Thus, from the facts mentioned above, we may say generally that any admixture retards the time of set in cement in any atmospheric condition except only that volcanic ash has the curious effect of accelerating the time of initial set in cases at a temperature higher than about 10° C., and in a humidity higher than about 60% ; that any admixture retards more the time of final set than that of initial set so that the duration of setting would be lengthened ; that the retardation effect is greater at a low temperature and nearly independent of the humidity ; that the amount of retardation and the duration of setting depend upon the kind of admixture used.

CHAPTER 4. EFFECTS OF TEMPERATURE AND HUMIDITY UPON THE STRENGTH OF MORTAR AND CONCRETE.

I. GENERAL REMARKS. •

The basis of all mortar and concrete is the union of inert materials by substances produced through chemical reaction between Portland cement and water. Any acceleration or retardation of this chemical process affects the quantity and quality of the binder resulting from this reaction ; and any such alteration affects critically the quality, strength, and endurance of the mortar and concrete formed by admixture of this binding product with sand and stone.

It has been shown in the preceding chapter that low temperature has a marked effect in increasing the time of set in cement, retarding the chemical union, often from two to two and half times as long a period being required to obtain a final set at a temperature of 5° C. as is required at normal temperature of 20° C. If water in mortar or concrete freezes

before the cement has set, it is not available for the chemical action of setting and hardening, hence the mortar or the concrete will not set at all until the ice melts. When also the cement or the sand possesses slow hardening properties, the mortar may remain soft enough to be broken with the fingers for several months after laying. On the other hand, the concrete of Portland cement even if set is obstructed by freezing, will eventually attain, after thawing, a fair ultimate strength with slight surface damage, if moisture is present or applied to permit proper hydration of the cement.

When the mortar or the concrete is exposed to high temperature for some time after it has been deposited, a part of the free water will disappear by evaporation before the chemical action of setting and hardening is completed, and the ultimate strength may be reduced, a condition brought on by deficiency of available water. Hence it is necessary to prevent such evaporation in order to obtain good results; and it is customary in practice to cover the surface of green concrete or mortar with canvas, sheeting, burlap, straw, etc., not to be exposed to the direct sun, specially during a few days in hot summer, it being wetted every day by sprinkling water on it and allowing it to set freely.

The amount of evaporation depends mainly upon the atmospheric temperature, and, furthermore, the humidity of the atmosphere affects it. Thus relative evaporation speeds at different temperatures and different degrees of humidity are also to be considered, with correlative effect on the strength of the mortar or concrete produced at a given time. It is reasonable to expect that mortar or concrete laid in a high atmospheric temperature is quick-setting and of early strength and that laid in a low atmospheric temperature is slow-setting and of slow strength.

The effect of freezing on the strength of mortar and concrete has been well studied, but the effect of high temperature and especially of humidity has rather been left out in the cold, as it were. A. B. Mc Daniel⁽¹⁰⁾ carried out an experiment at the University of Illinois and has

(10) Bulletin 81, Eng. Exp. Station, Univ. of Illinois.

determined the general effect of temperature on the strength of various mixtures of concrete. F. W. Taylor and S. E. Thompson⁽¹¹⁾ made up the curves illustrating the effect of different uniform temperatures upon cement mortar from a series of experiments carried out by J. E. Howard⁽¹²⁾ at Watertown Arsenal. In these experiments the humidity was left out of consideration and the temperatures measured were comparatively low. Therefore the present scribe carried out some experiments in testing to determine both the effects of temperature and of humidity upon the strength of mortar and of concrete, making the specimens set at different uniform temperatures with constant humidity, and at different uniform humidities with constant temperature.

2. EQUIPMENT AND APPARATUS.

The equipment and apparatus used to make the test specimens subject to constant temperature or humidity during the setting were just the same as those described in the preceding chapter.

3. TEST SPECIMENS

Test specimens were made of cement mortar in the proportion of 1 : 3, and of cement concrete in the proportion of 1 : 2 : 4. The form of the mortar specimen was a cube each side of which had a surface area of 50 sq. cm. ; and the concrete specimen was in form a cylinder of 10 cm. in diameter and 15 cm. long. Standard sand was used for the mortar specimen, and Kidzu river sand and Kamo river gravel were used for the concrete specimen.

4. TESTING.

The mixing of the materials for mortar and concrete was made in the laboratory, sometimes using the water warmed a little lower than the chamber temperature in the testing box, for the reason mentioned already. After the mortar and concrete specimens had been made, the former being

(11) Taylor and Thompson, Concrete plain and reinforced, 1917.

(12) Tests of Metals. U. S. A. 1901.

taken out of the mould, the latter in moulded condition, they were placed immediately into the chamber of the testing box whose temperature and humidity had been regulated already to the required value and kept there until they were completely set. The setting of the specimens was carried out in the same chamber simultaneously with the testing of the time of set of cement hence the specimens were subjected either to uniform temperature from 5° to 50° C., jumping five degrees each time, under a constant humidity of about 80%, or to a uniform change of humidity from 40% to 100%, jumping 20% each time under a constant temperature of 15°—18° C., their complete sets could be indicated by the final set of the cement paste. Four specimens each of mortar and of concrete composing a set for the test, were used for each temperature and each humidity.

The mortar specimens were stored in water, the concrete specimens in the moist sand being taken out of the mould after they had been removed from the testing box and at the age of 28 days their compressive strength was tested by means of the Amslar-Laffon testing machine.

5. RESULTS OF TESTS.

A. Effect of Temperature.

Table XXV and XXVI show the results obtained in the strength test. The mean values were taken from three specimens having the greatest strength in each set. Fig. 23 is a curve sheet showing the variation of strength with relation to the different temperatures of setting. The curves have a very curious form, the strength in both mortar and concrete being raised and lowered alternately at each temperature.

The difference in strength between the lowest and the highest temperatures is only 4.9 kg per sq. cm. for the mortar and 5.4 kg per sq. cm. for the concrete. If we draw an average line on each curve, it lies nearly horizontal, and the maximum deviation of strength from the average line does not exceed about 10 percent. Thus we can say that the effect of temperature during the setting of mortar and concrete on their strength is not considerable.

Table XXV.

Cement mortar 1 : 3.

Constant humidity 80% during setting.

Amount of water mixed 7.3%.

No. of set	Temperature (C) in		Uniform chamber temp. (C)	Compressive strength in Kg/sq. cm.				
	labor.	water		a	b	c	d	mean
1	4.5	3.0	5	192.0	214.0	197.4	191.8	201.1
2	7.5	6.0	10	190.0	197.0	171.0	196.0	194.3
3	8.0	7.0	15	224.8	226.8	218.0	223.0	224.9
4	7.5	5.0	20	204.0	192.0	197.4	201.0	200.8
5	10.0	7.0	25	204.8	217.2	183.6	211.4	211.1
6	7.5	6.0	30	177.0	182.0	171.6	177.0	178.7
7	7.0	5.5	35	180.0	205.2	175.0	167.4	186.7
8	6.5	5.0	40	214.8	185.0	188.0	188.2	197.0
9	7.5	6.0	45	203.6	193.0	178.4	191.6	196.1
10	6.0	4.5	50	209.0	185.0	185.8	194.0	196.3

Table XXVI.

Concrete 1 : 2 : 4.

Constant humidity 80% during setting.

Amount of water mixed 5.7%.

No. of set	Temperature (C) in		Uniform chamber temp. (C)	Compressive strength in Kg/78.54 sq. cm.				
	labor.	water		a	b	c	d	mean Kg./sq.cm.
1	4.5	3.0	5	11380	9280	10770	9530	134.45
2	7.5	6.0	10	9900	10000	10550	10100	130.09
3	8.0	7.0	15	11260	12020	12900	12150	157.34
4	7.5	5.0	20	10770	8850	10850	8350	128.46
5	10.0	7.0	25	12320	12700	12220	10640	158.04
6	7.5	6.0	30	11050	12300	9600	10550	139.33
7	7.0	5.5	35	11650	9580	12500	11000	149.18
8	6.5	5.0	40	10850	11560	9570	11350	143.27
9	7.6	6.0	45	11070	11840	9670	11000	143.91
10	6.0	4.5	50	11000	11250	9590	10700	139.83

Table XXVII.

Cement mortar 1 : 3.
 Temperature 15°—18° (C.) during setting.
 Amount of water mixed 7.3%.

No. of set	Temperature (C) in		Humidity in %	Compressive strength in Kg./sq. cm.				
	labor.	water		a	b	c	d	mean Kg./sq. cm.
1	7.0	5.0	100	181.6	183.4	194.0	197.0	191.5
2	6.0	4.5	80	205.0	200.0	201.0	197.0	202.0
3	8.8	5.5	60	205.2	198.0	197.0	218.0	207.1
4	6.0	5.0	40	199.0	215.2	197.2	220.0	211.4

Table XXVIII.

Concrete 1 : 2 : 4.
 Temperature 15°—18° (C.) during setting.
 Amount of water mixed 5.7%.

No. of set	Temperature (C) in		Humidity in %	Compressive strength in Kg./78.54 sq. cm.				
	labor.	water		a	b	c	d	mean Kg./sq. cm.
1	7.0	5.0	100	6700	7560	7930	6520	94.18
2	6.0	4.5	80	11200	11000	10790	10200	140.00
3	8.8	5.5	60	11750	12000	11600	12600	154.28
4	6.0	5.0	40	11800	12320	11620	12720	156.35

B. Effect of Humidity.

Tables XXVII and XXVIII show the results obtained in the strength test. The mean values were taken from the three specimens having the greatest strength in each set. Fig. 24 is a curve sheet showing the variation of strength with relation to different humidities. These curves show that the strength decreases generally as the humidity rises. The decrease of strength in the mortar is approximately uniform, that in the concrete, however, is more rapid when the humidity is high.

If we assume the strength at the normal humidity of 80% as unity, the strength at different humidities is as follows ;

for mortar,

humidity	40	60	80	100%
strength	1.05	1.03	1.00	0.95

for concrete,

humidity	40	60	80	100%
strength	1.12	1.10	1.00	0.67

The variation of strength in the mortar is very small, not exceeding a mere 5 percent, that in the concrete, however, is more remarkable, especially on extremely high humidity.

Thus, we may say that the effect of humidity during the setting of mortar and concrete on the strength may be neglected without any likely error except in the case of the concrete at extremely high humidity.

CHAPTER 5. THERMAL EXPANSION OF CEMENT MORTARS WITH OR WITHOUT AN ADMIXTURE.

1. PURPOSE OF TEST.

It is well known that mortar and concrete expand or contract when they are subjected to temperature change just like other building materials. The investigation of the coefficient of the thermal expansion of mortar and of concrete is therefore one of the most important factors in preparing the materials for the construction use.

Various experiments to obtain the proper value of the coefficient of the thermal expansion have been carried out by several authorities. Shitkewitsch⁽¹²⁾ reviews very fully the data regarding the coefficient of expansion of various cement mortar and other building materials. His data regarding cement and concrete are quoted in full in Table XXIX. The figures of Keller, Haswell, Rae and Dougherty are added.

The average of all the figures for mortar is about 0.0000104 per degree of Centigrade or 0.0000058 per degree of Fahrenheit and for concrete

(12) "Monolität d. Betonbauten", Forscherarbeiten a. d. Gebiet d. Eisenbetons Heft 7, Berlin, 1913 or International Engineering Congress, 1915. Material of Engineering Construction.

is about 0.0000102 per degree C. or 0.0000057 per degree F.

The rate of expansion per degree of Fahrenheit for wrought iron and steel, as given by Kent, is from 0.0000065 to 0.0000069; and as given by the U. S. Government Reports on Iron and Steel, it varies from 0.0000062 to 0.0000068. The mean of these values is 0.0000065. This value is nearly equal to that of mortar and concrete and it is evident that no special consideration need be taken in regard to the relative coefficient of expansion of steel and concrete in a structure subjected to ordinary temperatures.

Thus the thermal expansion of mortar and concrete has been comparatively well investigated. For the influence of different proportions

Table XXIX.

Coefficient of thermal expansion of cement, mortar and concrete.

Materials	Linear coefficient of expansion		Authority
	per degree C.	per degree F.	
Neat cement	0.0000122	0.0000068	Meier
"	0.0000145	0.0000081	"
"	0.0000143	0.0000079	Adie
"	0.0000107	0.0000059	Bouniceau
"	0.0000137	0.0000076	Hyatt
"	0.0000140	0.0000078	"
"	0.0000126	0.0000070	Keller
"	0.0000144	0.0000080	Haswell
Mortar 1:3	0.0000118	0.0000066	Bouniceau
" 1:1	0.0000110	0.0000061	Keller
" 1:2	0.0000101	0.0000056	"
" 1:4	0.0000104	0.0000058	"
" 1:6	0.0000092	0.0000051	"
" 1:8	0.0000095	0.0000053	"
" 1:2	0.0000101	0.0000056	Rae and Dougherty
Concrete 1:2:4 (Bedford lime stone)	0.0000098	0.0000054	Pence
" 1:2:4 (Kankakee lime stone)	0.0000101	0.0000056	"
" 1:2:4 (gravel)	0.0000097	0.0000054	"
" 1:5 (gravel)	0.0000095	0.0000053	"
" 1:2:5 (gravel)	0.0000119	0.0000066	Rae and Dougherty

to the thermal expansion however, we know but little and as for the effect of admixtures the author does not know how the investigation has been developed.

As the various experiments show, the thermal expansion of mortar does not differ very much from that of concrete, and therefore we may deduce the latter without any appreciable error from the results obtained for the former. So, the author intended boldly to attempt an experiment to learn the relation between the thermal coefficient of expansion and the different proportions in mortar, and also to determine the effect of admixtures much used in practice such as hydrated lime, volcanic ash and infusorial earth.

2. TEST SPECIMENS.

Tests were made on several specimens of different proportions with or without an admixture as shown in Table XXX.

Table XXX.

No.	Proportion	Amount of water mixed (in percent)
Portland cement mortar. ("cement mortar")		
	Cement Sand	
1	1 : 0.5	16.5
2	1 : 1.0	19.2
3	1 : 1.5	14.6
4	1 : 2.0	13.3
5	1 : 3.0	11.0
6	1 : 4.0	10.2
7	1 : 5.0	9.5
Portland cement mortar mixed with hydrated lime. ("lime mortar")		
	Cement Lime Sand	
8	0.9 : 0.1 : 3.0	13.5
9	0.8 : 0.2 : 3.0	15.0
10	0.7 : 0.3 : 3.0	16.0
11	0.6 : 0.4 : 3.0	17.0

No.	Proportion			Amount of water mixed (in percent)
Portland cement mortar mixed with volcanic ash. ("ash mortar")				
	Cement	Ash	Sand	
12	0.9	: 0.1	: 3.0	15.0
13	0.8	: 0.2	: 3.0	14.5
14	0.7	: 0.3	: 3.0	14.0
15	0.6	: 0.4	: 3.0	14.0
16	0.5	: 0.5	: 3.0	14.0
Portland cement mortar mixed with infusorial earth. ("earth mortar")				
	Cement	Earth	Sand	
17	0.9	: 0.1	: 3.0	15.0
18	0.8	: 0.2	: 3.0	17.0
19	0.7	: 0.3	: 3.0	20.0
20	0.6	: 0.4	: 3.0	25.0
21	0.5	: 0.5	: 3.0	25.0

(in each case the standard sand was used.)

Each specimen was a cylinder in form of 1.36 cm. diameter and 10 cm. length and the specimen was molded in the brass tube made specially for testing use. Each specimen was left for the first two days covered with a wet cloth, after which it was taken out of the mould and stored in water until the day before the testing.

3. EQUIPMENT AND APPARATUS.

In the testing special equipment and apparatus were used. Fig. 25 shows the general view of the equipment.

Test specimen *T* was inserted into the silica tube *S* whose diameter is slightly greater than that of the specimen, in such a manner that the rounded end of the specimen exactly touches the bottom of the tube, and the other end which is liable to expand freely is in contact with the small silica tube *s*. The large tube is fixed at one end and its greater part is put in the furnace for the testing. The small tube passes over the small wheel *w* outside the large tube, and it presses the specimen a little by the friction on the wheel which tends to revolve by means of the small counter weight *g*. The brass piece *C* having a small hole in each end connects

with two pins, the one is situated near the free end of the small silica tube *s* and the other at an eccentric point in wheel *W*, both being firmly fixed. The fine rod *P* is a pointer, whose one end is fixed to the wheel *W* and the other end may slide along the graduated arc *G*. *F* is a tubular resistance furnace and it supplies the heating temperature of the required degree to the specimen, the temperature is measured by means of a thermocouple which is so inserted in the small tube *s* as to touch the bottom. Before the testing the graduation arc was calibrated directly by using the micrometer screw in place of the test specimen and the pyrometer was carefully checked and corrected.

4. TESTING.

On the day before the testing, each specimen was taken out of the water and laid in a hot air bath, the temperature being kept at 120° C. constantly for three hours to expel the moisture contained in the specimen, and then cooled gradually.

At age of 28 days the specimen was placed in the furnace for the testing, it being inserted in the large silica tube with the small silica tube as shown in Fig. 25. At first the temperature was raised to about 100° (or 200°) C. in about 10 minutes and keeping it as constant as possible for 20 minutes, the temperature was raised again about 100° (or 200°) C. or more and the process continued up to the final temperature. It took about 4 (or 6) hours for the testing up to the temperature 900° C.

The elongation of the specimen caused by being heated shifts the end of pointer along the graduated arc and the amount can be directly observed.

As we know the fused silica is a good heat conductor and although the mortar has low thermal conductivity, it may be thought that the whole mass of the mortar would be heated uniformly at the end of constant temperature during twenty minutes as it receives the heat from all sides and its diameter is very small. Hence the observation of the elongation was always taken at the end of a constant temperature intermediately.

The observed amount of the elongation, however, does not indicate the true thermal expansion of the mortar since it is affected by the elongation of the silica tubes. The large tube elongates toward the free end as one end is firmly fixed and the small tube too, toward the same direction pressing the specimen into the bottom of the former. Since the elongation of the overlapping length in both tubes cancels each other and the effect of elongation for the outer part of the small tube is almost negligible due to the fact that the temperature outside of the furnace is very low and that the thermal expansion of fused silica is very small, the observed amount of elongation must be the difference between that in the specimen and that in the large silica tube with the same length.

Now, let

- E , be the observed amount of elongation in the testing,
- e , the true elongation of the specimen,
- S , the elongation of the silica tube having the same length as the specimen,

then we have

$$E = e - S$$

$$\therefore e = E + S$$

The elongation of the silica tube, S , can be determined by the ordinary formula

$$S = c t l$$

where

- t , temperature in degrees C.,
- l , length of silica tube, here equals that of the specimens,
- c , coefficient of thermal expansion of fused silica. The value is well determined and according to Le Chatlier it is taken as 0.0000007 per degree C.

By the principle mentioned above, the true elongations caused by several temperatures were calculated and the coefficient of thermal expansion determined.

Table XXXI.

No.	Proportion	Temp. in degrees C.	Expansion mm./100mm. long	Thermal coef.	Temp. in degrees C.	Expansion mm./100mm. long	Thermal coef.
1	C 1.0 : S 0.5	20—300	0.160	0.00000571	300—500	0.349	0.00001745
2	C 1.0 : S 1.0	20—350	0.295	0.00000894	300—500	0.205	0.00001767
3	C 1.0 : S 1.5	20—300	0.335	0.00000836	300—400	0.165	0.00001650
4	C 1.0 : S 2.0	20—370	0.456	0.00001303	370—559	0.398	0.00002211
5	C 1.0 : S 3.0	20—150	0.210	0.00001615	150—315	0.362	0.00002194
6	C 1.0 : S 4.0	20—150	0.171	0.00001315	150—320	0.416	0.00002447
7	C 1.0 : S 5.0	20—120	0.168	0.00001680	120—300	0.373	0.00002072
8	C 0.9 : L 0.1 : S 3	20—150	0.221	0.00001700	150—320	0.411	0.00002418
9	C 0.8 : L 0.2 : S 3	20—220	0.345	0.00001725	220—350	0.365	0.00002080
10	C 0.7 : L 0.3 : S 3	20—300	0.455	0.00001625	300—500	0.620	0.00003100
11	C 0.6 : L 0.4 : S 3	20—300	0.425	0.00001518	300—500	0.495	0.00002475
12	C 0.9 : A 0.1 : S 3	20—300	0.401	0.00001432	300—500	0.484	0.00002420
13	C 0.8 : A 0.2 : S 3	20—300	0.430	0.00001536	300—575	0.800	0.00002909
14	C 0.7 : A 0.3 : S 3	20—300	0.414	0.00001479	300—500	0.461	0.00002305
15	C 0.6 : A 0.4 : S 3	20—300	0.441	0.00001575	300—540	0.667	0.00002779
16	C 0.5 : A 0.5 : S 3	20—300	0.414	0.00001475	300—500	0.521	0.00002605
17	C 0.9 : E 0.1 : S 3	20—300	0.501	0.00001789	300—500	0.551	0.00002755
18	C 0.8 : E 0.2 : S 3	20—300	0.431	0.00001530	300—500	0.534	0.00002670
19	C 0.7 : E 0.3 : S 3	20—300	0.465	0.00001661	300—500	0.555	0.00002775
20	C 0.6 : E 0.4 : S 3	20—300	0.445	0.00001589	300—500	0.450	0.00002250
21	C 0.5 : E 0.5 : S 3	20—300	0.451	0.00001611	300—500	0.559	0.00002795

(Continued)

1	C 1.0 : S 0.5	500—720	0.335	0.00001523	720—850	-0.110	
2	C 1.0 : S 1.0	500—690	0.438	0.00002526	690—900	0.002	0.00000010
3	C 1.0 : S 1.5	400—610	0.738	0.00003514	610—800	0.003	0.00000010
4	C 1.0 : S 2.0	550—740	0.607	0.00003195	740—900	0.009	0.00000056
5	C 1.0 : S 3.0	315—520	0.904	0.00004410	520—700	0.028	0.00000156
6	C 1.0 : S 4.0	320—515	0.919	0.00004623	515—700	0.024	0.00000138
7	C 1.0 : S 5.0	300—460	0.871	0.00005443	460—675	0.135	0.00000626
8	C 0.9 : L 0.1 : S 3	320—500	0.828	0.00004600	500—690	0.018	0.00000095
9	C 0.8 : L 0.2 : S 3	350—580	0.821	0.00003570	580—800	0.005	0.00000023
10	C 0.7 : L 0.3 : S 3	500—750	0.558	0.00002232	750—900	0.005	0.00000023
11	C 0.6 : L 0.4 : S 3	500—700	0.594	0.00002970	700—785	0.041	0.00000482
12	C 0.9 : A 0.1 : S 3	500—675	0.642	0.00003669	675—695	0.002	0.00000100
13	C 0.8 : A 0.2 : S 3	575—590	0.236	0.00015733	590—720	0.154	0.00001184
14	C 0.7 : A 0.3 : S 3	500—735	0.706	0.00003004	735—900	0.002	0.00000012
15	C 0.6 : A 0.4 : S 3	540—675	0.519	0.00003844			
16	C 0.5 : A 0.5 : S 3	500—690	0.633	0.00003332			
17	C 0.9 : E 0.1 : S 3	500—520	0.264	0.00013200	520—685	0.162	0.00000082
18	C 0.8 : E 0.2 : S 3	500—535	0.222	0.00006343	535—680	0.241	0.00001662
19	C 0.7 : E 0.3 : S 3	500—695	0.479	0.00002456			
20	C 0.6 : E 0.4 : S 3	500—700	0.464	0.00002320	700—740	-0.037	
21	C 0.5 : E 0.5 : S 3	500—550	0.359	0.00007180	550—700	0.131	0.00000873

(Continued)

5	C 1.0 : S 3.0	700—850	-0.054				
6	C 1.0 : S 4.0	700—840	-0.101				
7	C 1.0 : S 5.0	675—780	0.008	0.00000076			
13	C 0.8 : A 0.2 : S 3	720—850	0.010	0.00000769			
17	C 0.9 : E 0.1 : S 3	685—800	0.008	0.00000070			
18	C 0.8 : E 0.2 : S 3	680—750	0.035	0.00000500			

5. RESULTS OF TESTS.

Fig. 26 a—d show the relation between the heating temperature and the expansion of the test specimen. The rate of expansion is not uniform, it varying with the temperature range. Table XXXI gives the thermal coefficients of expansion of mortars at different temperature ranges. These are calculated in each temperature range at which the rate of expansion is considered as approximately uniform.

These results show us that when any mortar of various proportions either with or without an admixture is heated up to high temperature, its thermal coefficient of expansion is not constant, varying considerably with the temperature range. The coefficient increases approximately up to 500° or 700° C. according to the kind of mortar, reaching about two or more times the value at lower temperature, but it becomes smaller at higher temperature and a few shows a slightly negative value.

In cement mortar the coefficient decreases generally with the richness of the cement and this fact contradicts the result of Keller's experiment (see Table XXIX.). The value for 1:3 cement mortar at low heating temperature below 150° C. is 0.00001615 per degree C., being greater than the commonly accepted value of 0.00001. In lime mortar the coefficient decreases generally with the amount of hydrated lime mixed and the average value at low heating temperature below 150° C. is 0.00001642 per degree C. being approximately equal to that of 1:3 cement mortar within the same temperature range. Both ash and earth mortars have about the same value of the coefficient in same temperature range respectively, not depending on the different proportion. The average value for all ash mortars at low heating temperature below 300° C. is 0.00001500 and for all earth mortars at the same temperature is 0.00001618 per degree C. All mortars having three parts of sand either with or without any admixture have about the same value of the thermal coefficient of expansion at low heating temperature below 150° C. except that of the ash mortar is slightly less, it means that no admixture has any considerable effect on the thermal expansion at such a low temperature range. At higher temperature range

the coefficient varies moderately and some give exceptionally great expansion.

Thus, we may say that the thermal coefficient of expansion of any mortar may be assumed as constant at only a lower temperature range than 150° C. and assuming both mortar and concrete have the same value of the coefficient, that in designing a concrete structure subject to the ordinary atmospheric temperature change only, the constant coefficient may be used, in designing the structure exposed to intense heat, however, it is by no means wise to assume the same value and the greater value according to the temperature range should be used. According to the author's experiment it is preferable to take 0.000016 as the coefficient for 1 : 3 and 0.00001 for a mortar as rich as 1 : 1. But he does not persist in it, as his experiment was carried out with a comparatively small number of specimens and when the test specimens were only four weeks of age. In reinforced concrete it is assumed that both the materials of concrete and steel have about the same value of thermal coefficient, considering the value commonly for the former to be 0.00001 and for the latter to be 0.000012 per degree C.

Strictly speaking, the assumption is not correct, but for the concrete ordinarily used as the reinforced concrete, the difference between the thermal coefficients of concrete and steel at low temperature range is so considerably small that the assumption may be applied without appreciable error in practice. At high temperature range such as in 500° C. or more, however, the assumption is quite erroneous,* and when both concrete and steel embedded in it receive heat as intense as 500° C. or more, a considerably high thermal strain would be caused certainly between them since the difference of the thermal coefficient in these materials is considerably great at such a high temperature range.

* With regards to the thermal coefficient of iron and steel, it is stated in "Hütte des Ingenieur Taschenbuch I (1920, S. 369 & 371)",

for iron and steel $e = 0.000011$
 for cement and concrete $e = 0.000014$ } in temperature range between 0 and 100° C.
 and for iron and steel in high temperature, following relation exists,

$$1000 e = 0.011 + 0.000008t$$

in which t represents the temperature in degree C.

GENERAL CONCLUSIONS.

General conclusions obtained from the various experiments described already will be summarized in the followings pages.

Compressive strength of mortar both with and without an admixture such as volcanic ash and infusorial earth, is raised by heating them up to about 300° C., the percentage gain of the strength varies from 20 to 150 percent according to the kind of mortar and the greatest strength ratio is raised generally in accordance with the smaller amount of cement in the mixture. Quenching reduces always the strength got by heating. Loss of strength in every mortar by heating, especially by quenching at high temperature such as 800° C. or more is decidedly great. The mortar containing an admixture is more fire resistant relatively than the cement mortar in some region of heating temperature since the rate of decrease on strength due to heating and quenching in the former is less than that in the latter.

The compressive strength of concrete is increased also by heating it up to 400° C. and by quenching up to 200° C. and then the strength continues to decrease until the highest temperature of 900° C. is reached, more remarkably by quenching.

The tensile strength of neat cement is always decreased both by heating and by quenching, cement mortar, however, gains strength up to 200° C. or more by heating and up to 100° C. or more by quenching, and hence the latter is more fire resistant than the former.

Gravel concrete has a very low thermal conductivity and the proportion of the concrete has no remarkable effect on the thermal conductivity, except that in a linear mixture such as 1 : 4 : 8 it is a little less than in the other. The distribution of heat is not uniform in the concrete, being greater at the part near to the heated surface.

The rate of heat transmission through the concrete mass may be expressed approximately by the following equation,

$$y = \frac{a}{\beta + x} - r$$

in which the constants a , β and γ vary with the proportion of concrete using the same cement and aggregates and the temperature at the exposed surface. Since the concrete receives the less effect of temperature in its interior part than the outer surface, the deformation of the concrete due to the temperature change should be considerably less than that generally believed. Any reinforcement used to prevent the crack produced by temperature change in the concrete should be inserted as near as possible to the exposed surface and the thermal stress actually produced in the reinforcement by such a cause would be remarkably less than that calculated from the usual formula, the error however, is always on the safe side.

Atmospheric temperature has a remarkable effect on the setting time in cement both with and without any admixture. The lower temperature retards and the higher temperature accelartes the time of set, both initial and final. The rate of variation however, is not uniform, being greater at the lower temperature. The general formula showing the velocity of chemical reaction

$$\log \frac{1}{z} = -\frac{a}{273+t} + \beta$$

is also applicable to express the relation between the atmospheric temperature and the setting time in cement either with or without an admixture.

Tetmajer's formula

$$z = \frac{a}{b+t} + c$$

and the author's formula

$$z = a + b t + c t^2$$

are both applicable to show the relation too. As a whole, of these three formulæ the last agrees most with the result actually observed.

The humidity in the atmosphere has no considerable effect on the time of set in cement either with or without an admixture. As a rule, however, the higher humidity tends to retard the time of set a little.

Any admixture retards the setting time in cement and lengthens the duration of setting generally.

Thus we see that it is very important to specify a standard temperature at the testing in Portland cement and that where any admixture is used it is irrational to follow the regulation specified for the cement only, it should specify a time later than that of cement.

Atmospheric temperature higher than 5° C. during the setting of mortar and concrete does not have much effect on the strength. The effect of humidity during the setting of mortar and concrete on the strength may be neglected without reasonable error except for the concrete at extreme high humidity in which the strength is reduced about 30 percent.

The rate of expansion of any mortar either with or without an admixture, caused by temperature change is not uniform, varying with the temperature range and hence the thermal coefficient of expansion in the mortar is not constant through the temperature range.

The coefficient increases approximately up to about 500° or 700° C. according to the kind of mortar, reaching about two or more times of the value at lower temperature, but becomes smaller at higher temperature and some give a slightly negative value. The coefficient decreases generally with the richness of cement in cement mortar and with the amount of hydrated lime mixed in lime mortar. Both ash and earth mortars, however, have about the same value of the coefficient at same temperature range respectively, not depending on the amount of admixture. No admixture has any considerable effect on the thermal expansion of mortar at low temperatures below 150° C. The average value of the coefficient is 0.000016 for 1:3 and 0.000010 for 1:1 cement mortar at such a low temperature range. We may use such a constant coefficient in designing the concrete structure subject to the atmospheric temperature only, assuming both mortar and concrete have the same coefficient, and in designing a structure to be subjected to intense heat, however, the greater value according to the temperature range should be used.

The assumption that both materials of concrete and steel have about the same value of thermal coefficient may be correct only at low temperature range. At high temperature range such as in 500° C. or more, however,

the assumption is quite erroneous, the difference of the coefficients in these materials being then considerably great.

THE END.

Fig. 1

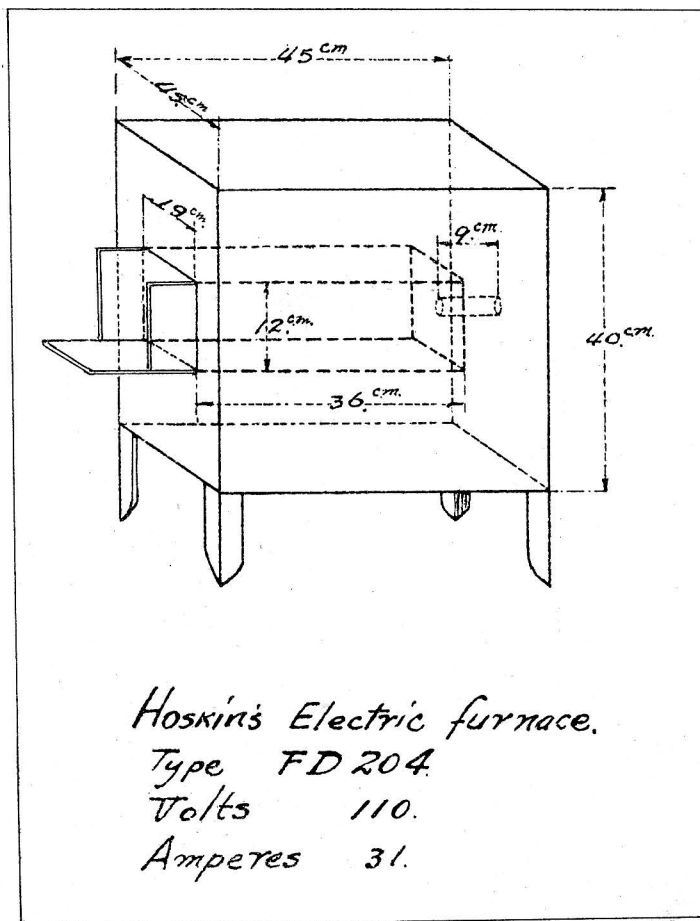

Fig. 1_b

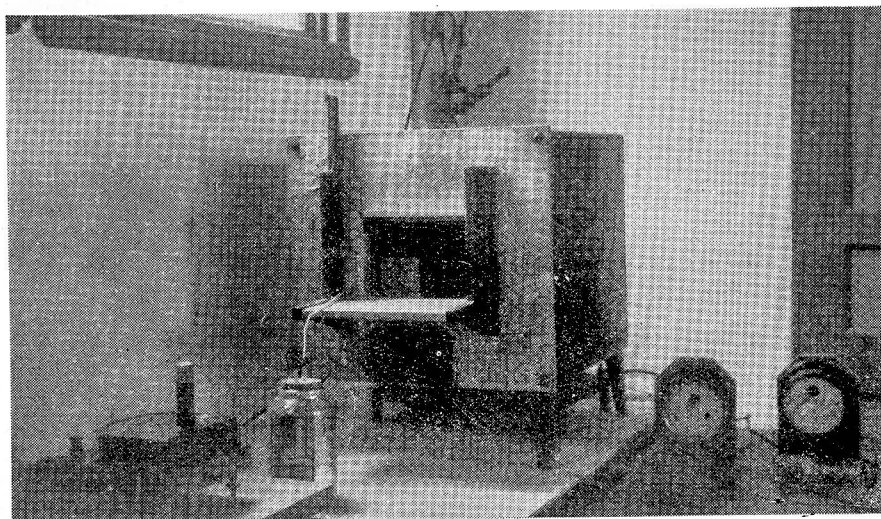

Fig. 2.

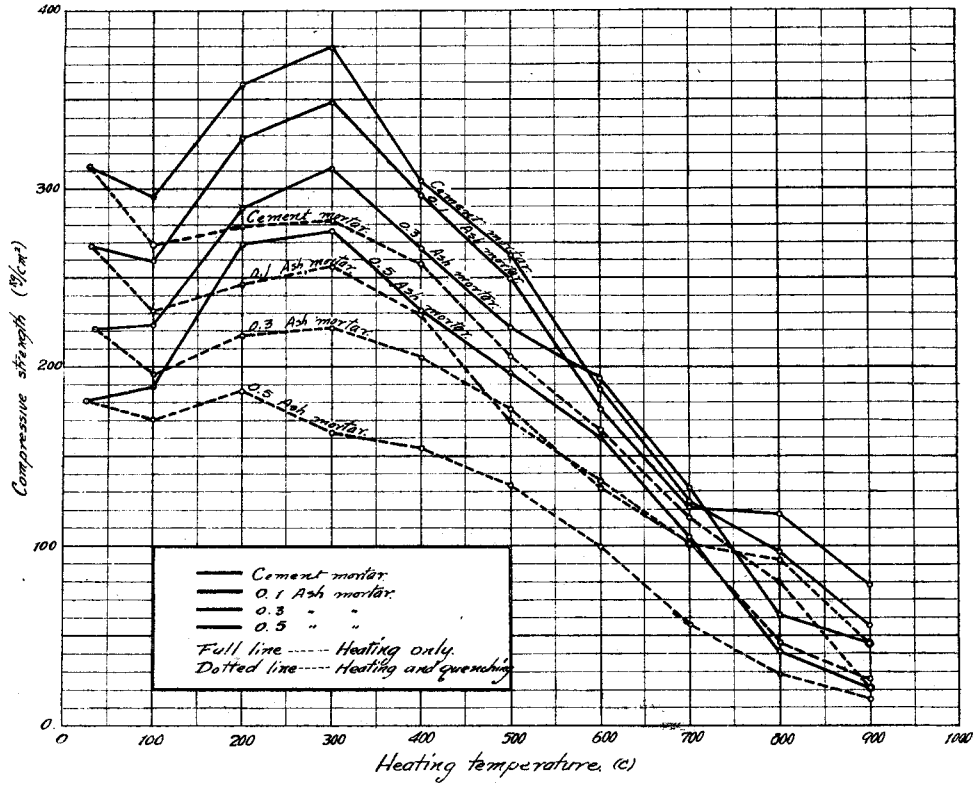

Fig. 3.

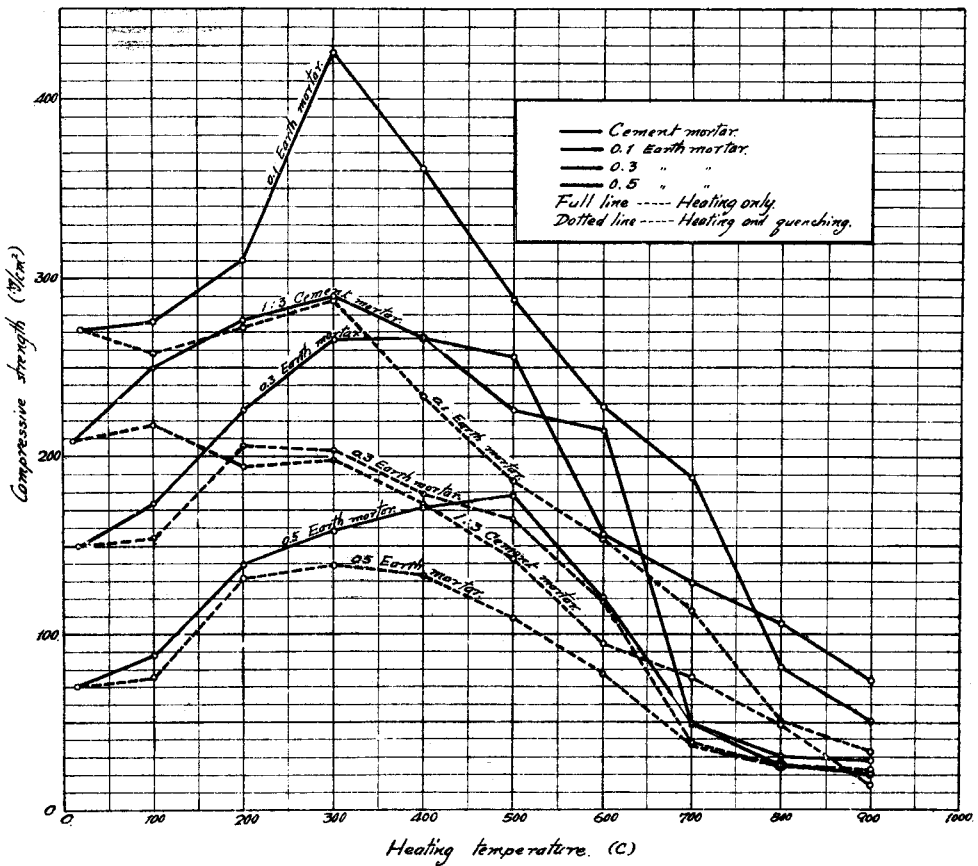

Fig. 4.

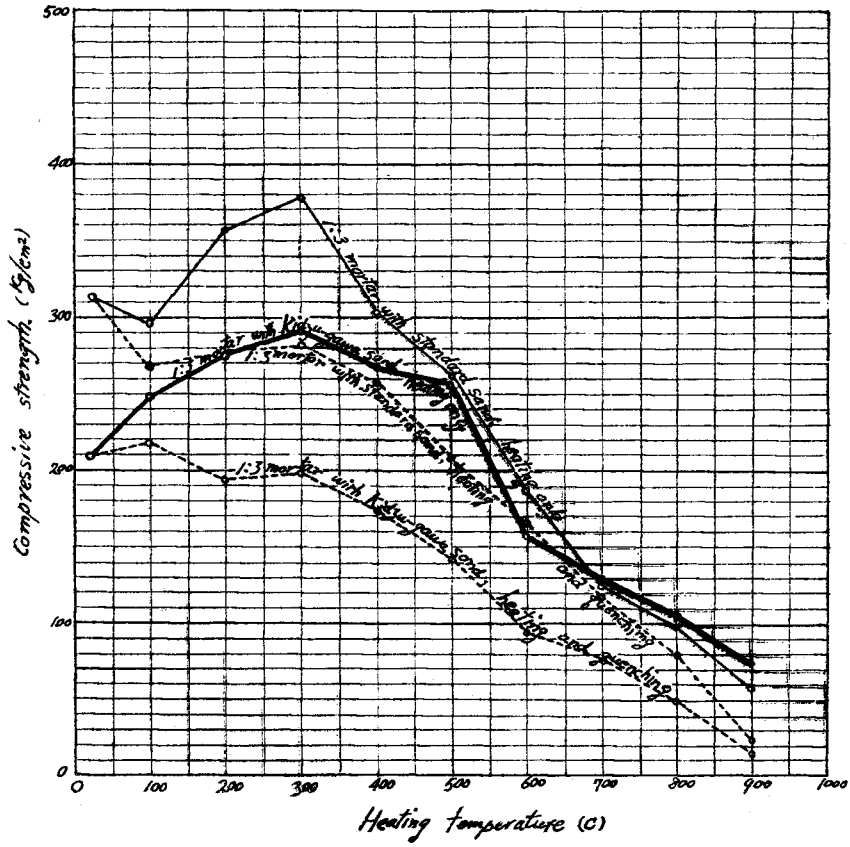

Fig. 5.

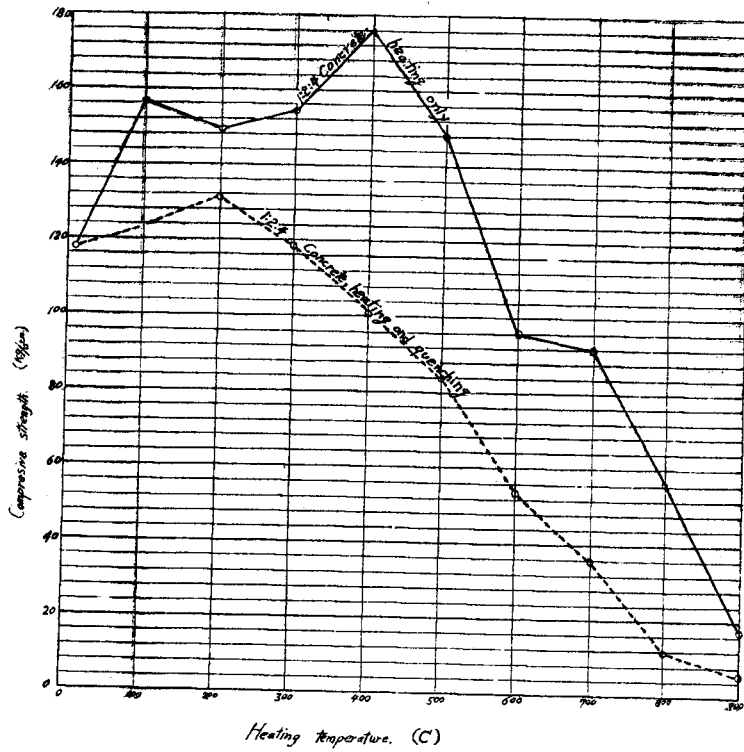

Fig. 6.

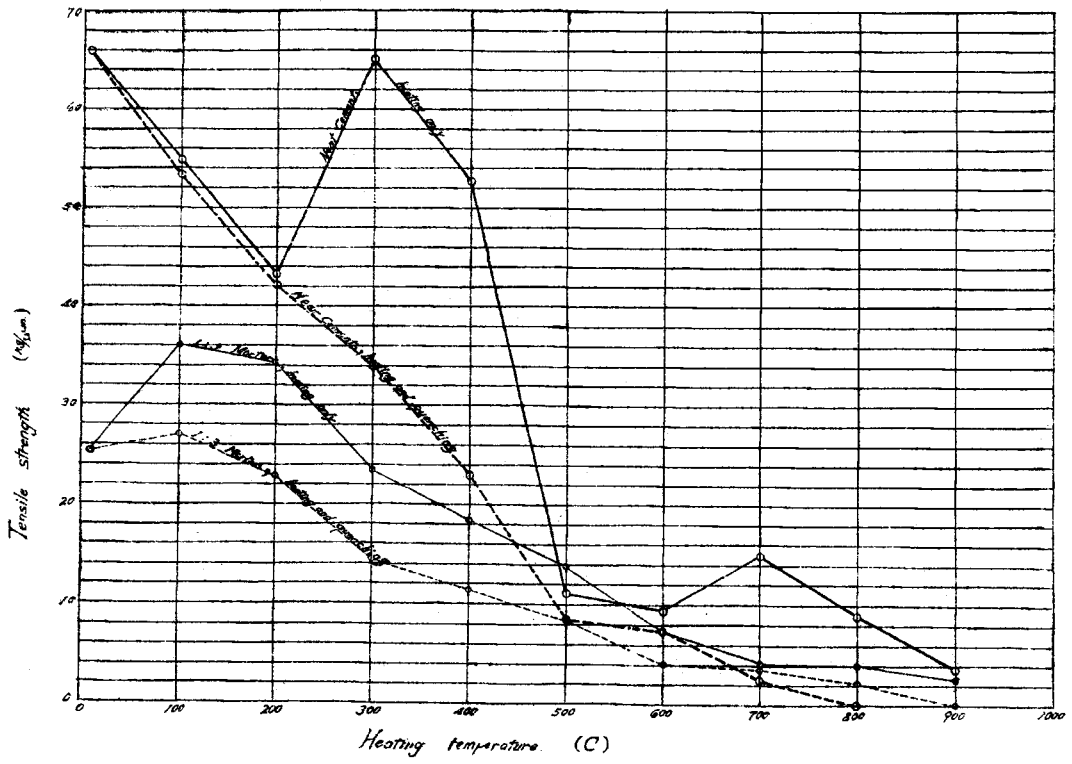

Fig. 7

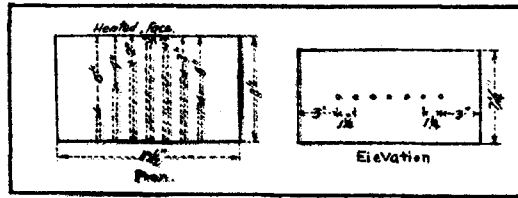

Fig. 8.

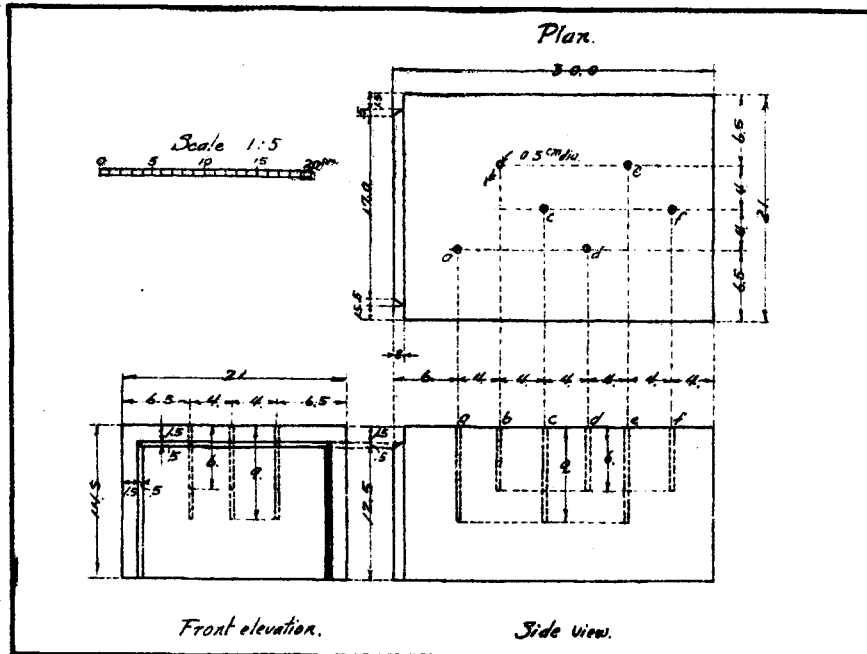

Fig. 9a

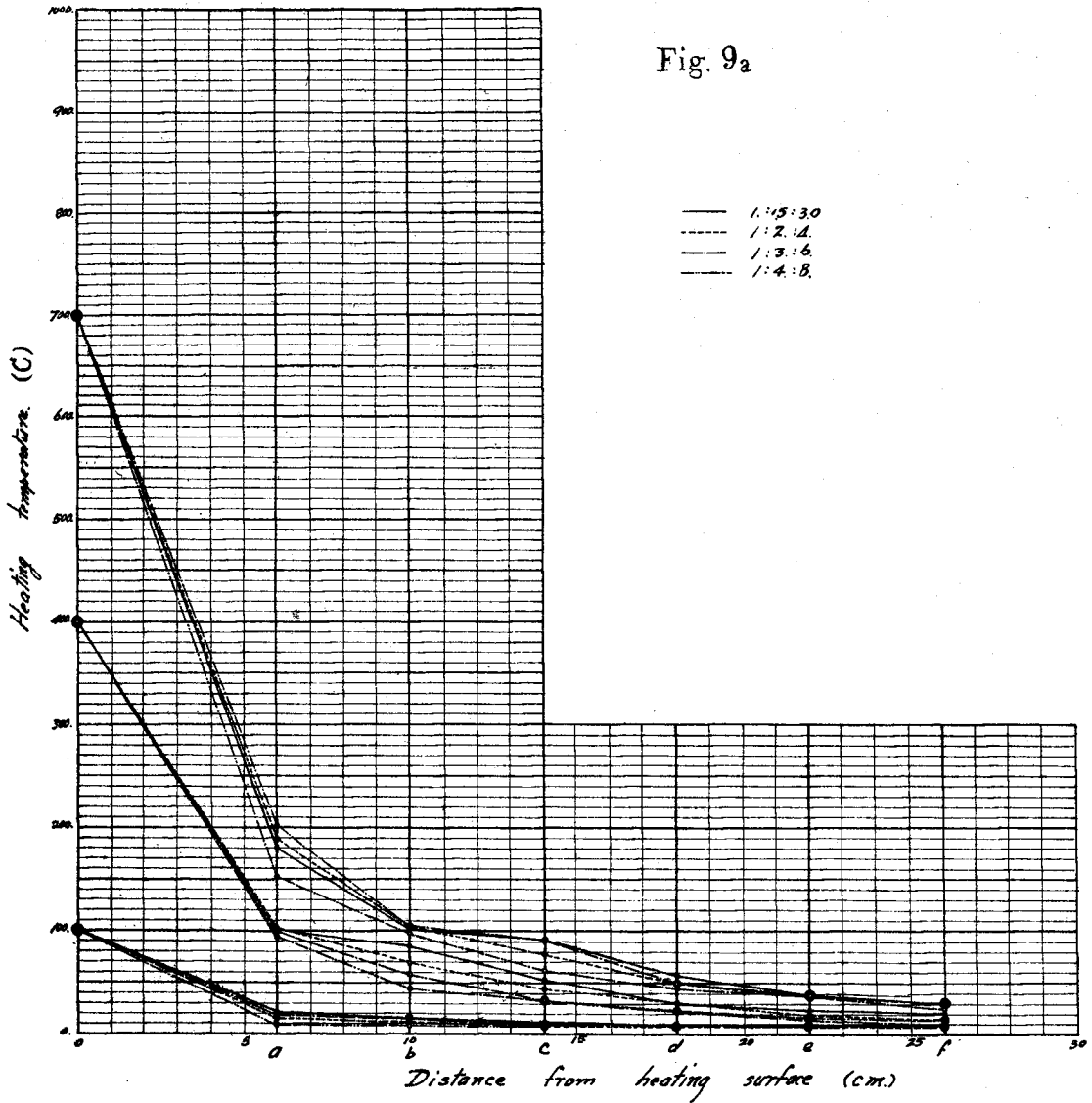

Fig. 9_b

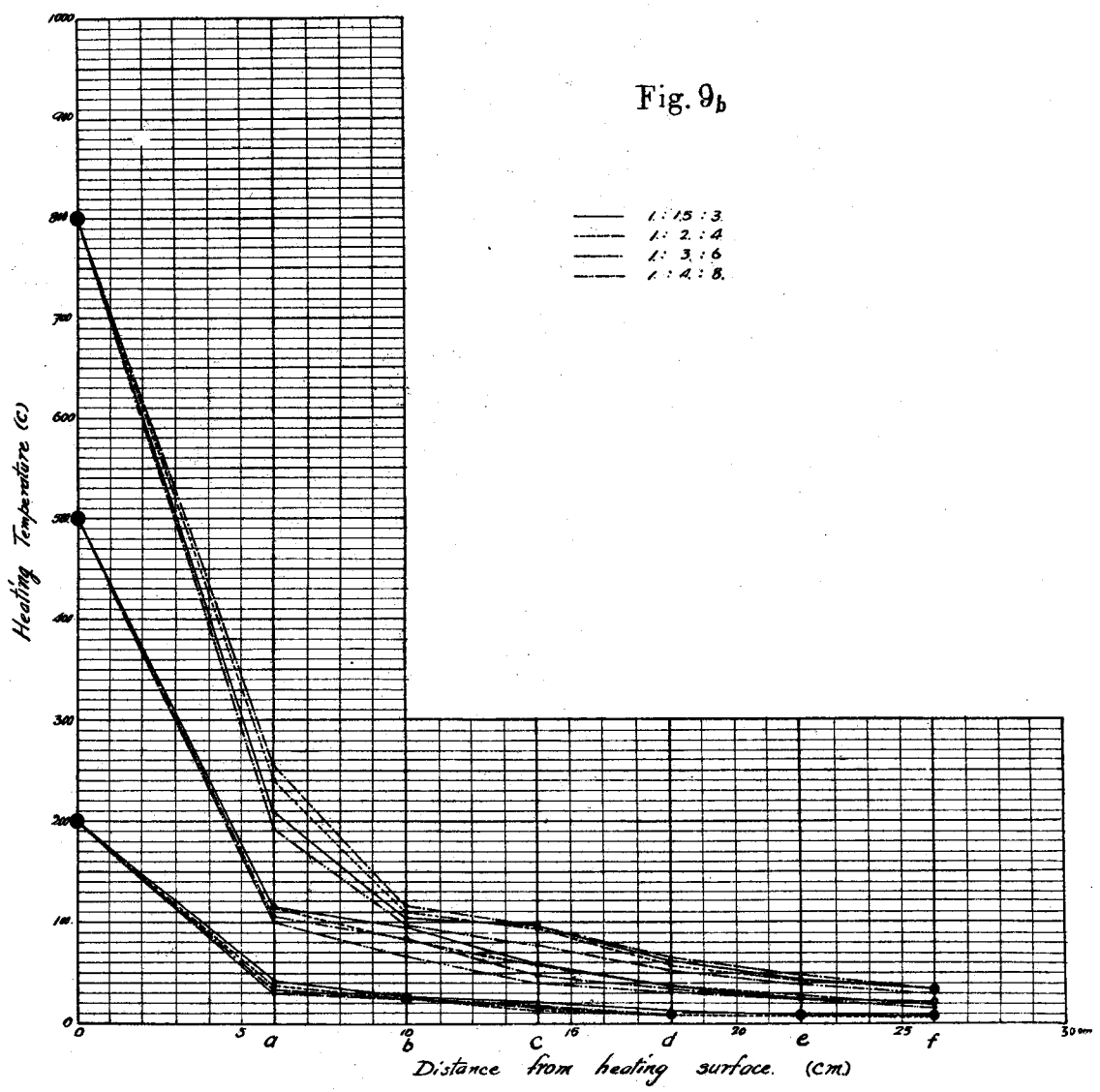

Fig. 9c

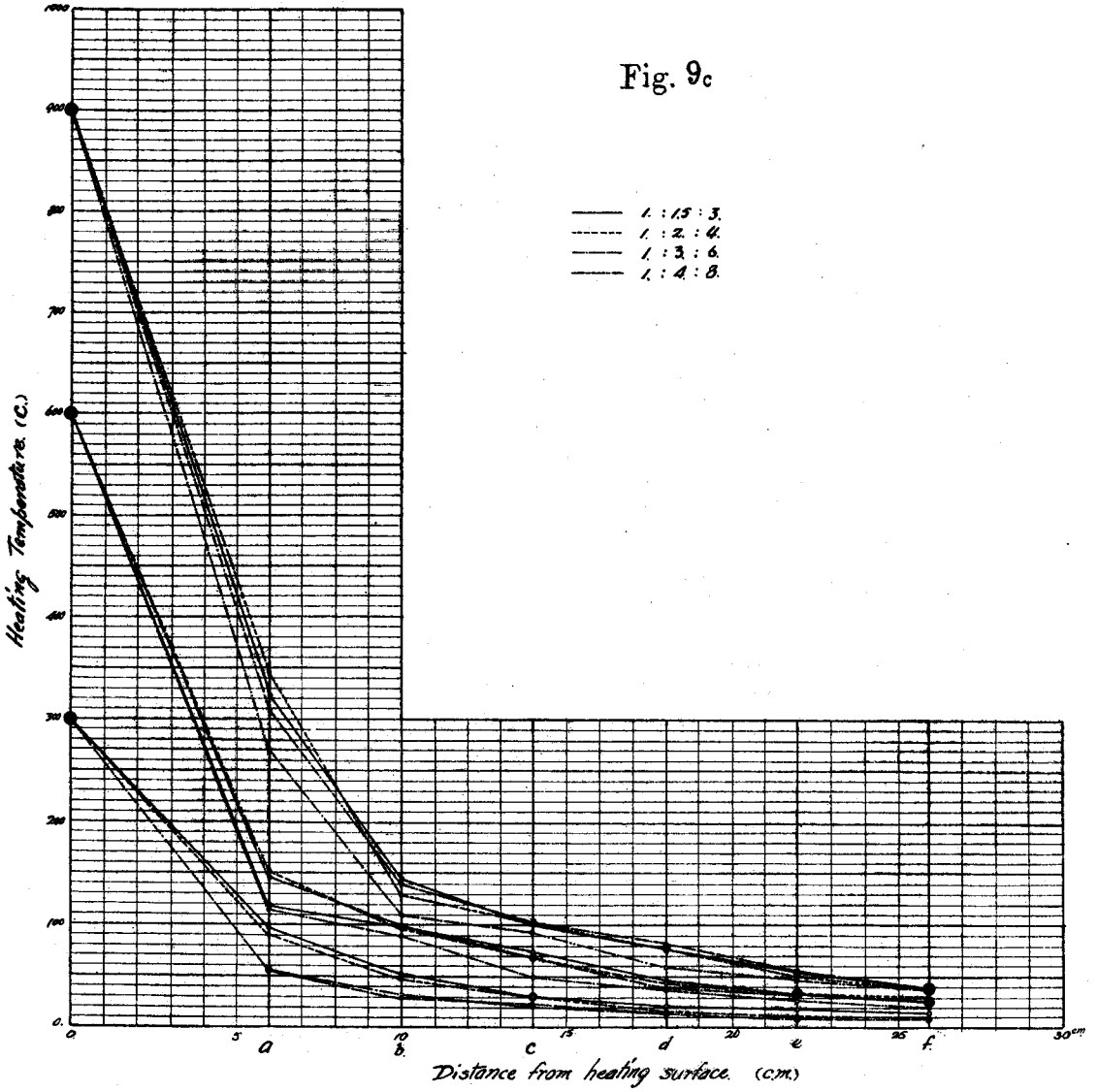

Fig. 10

$l : 15 : 3$
Temperature at exposed surface 400°C .

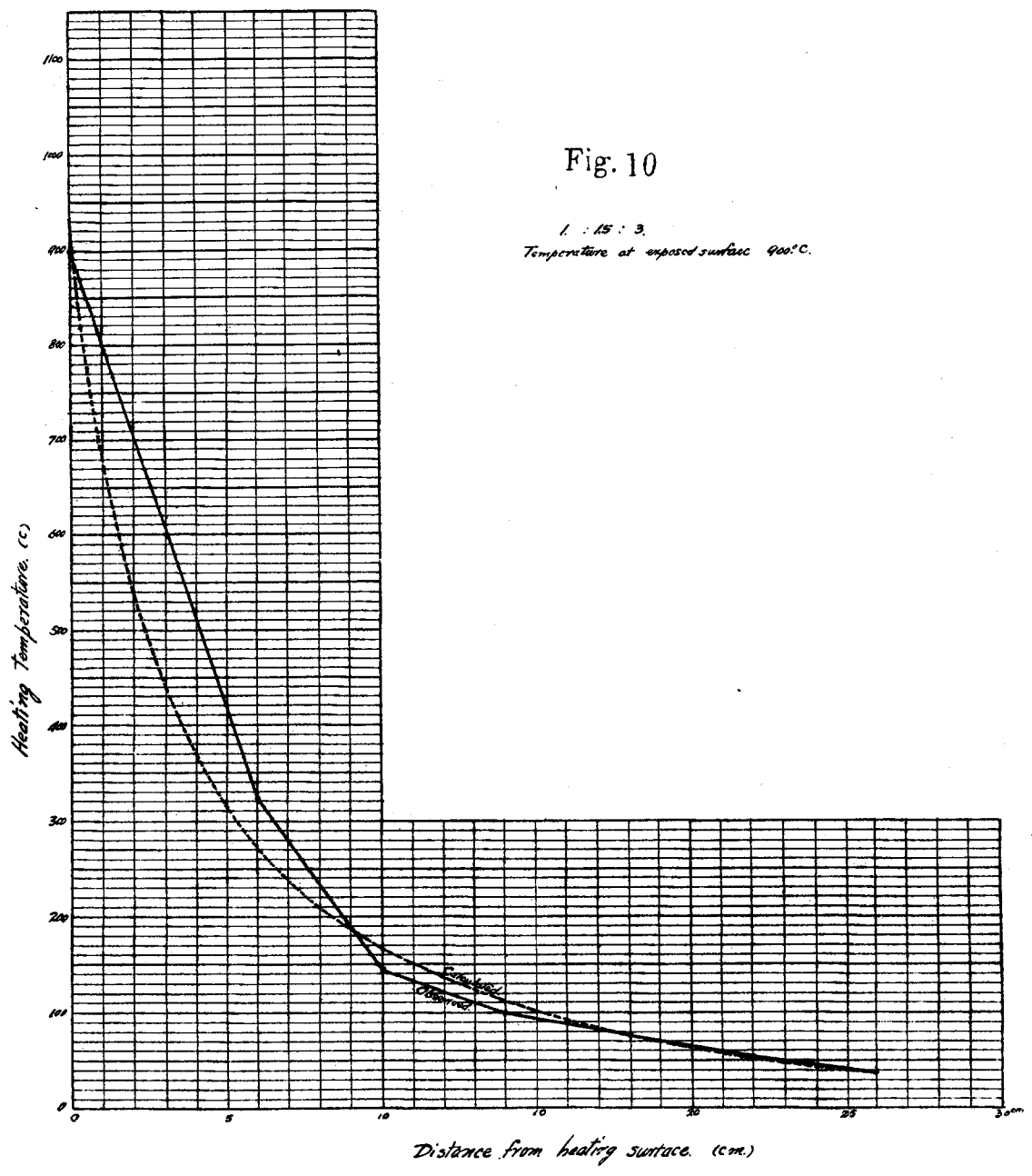

Fig. 11.

1 : 2 : 4

Temperature of exposed surface 900°C.

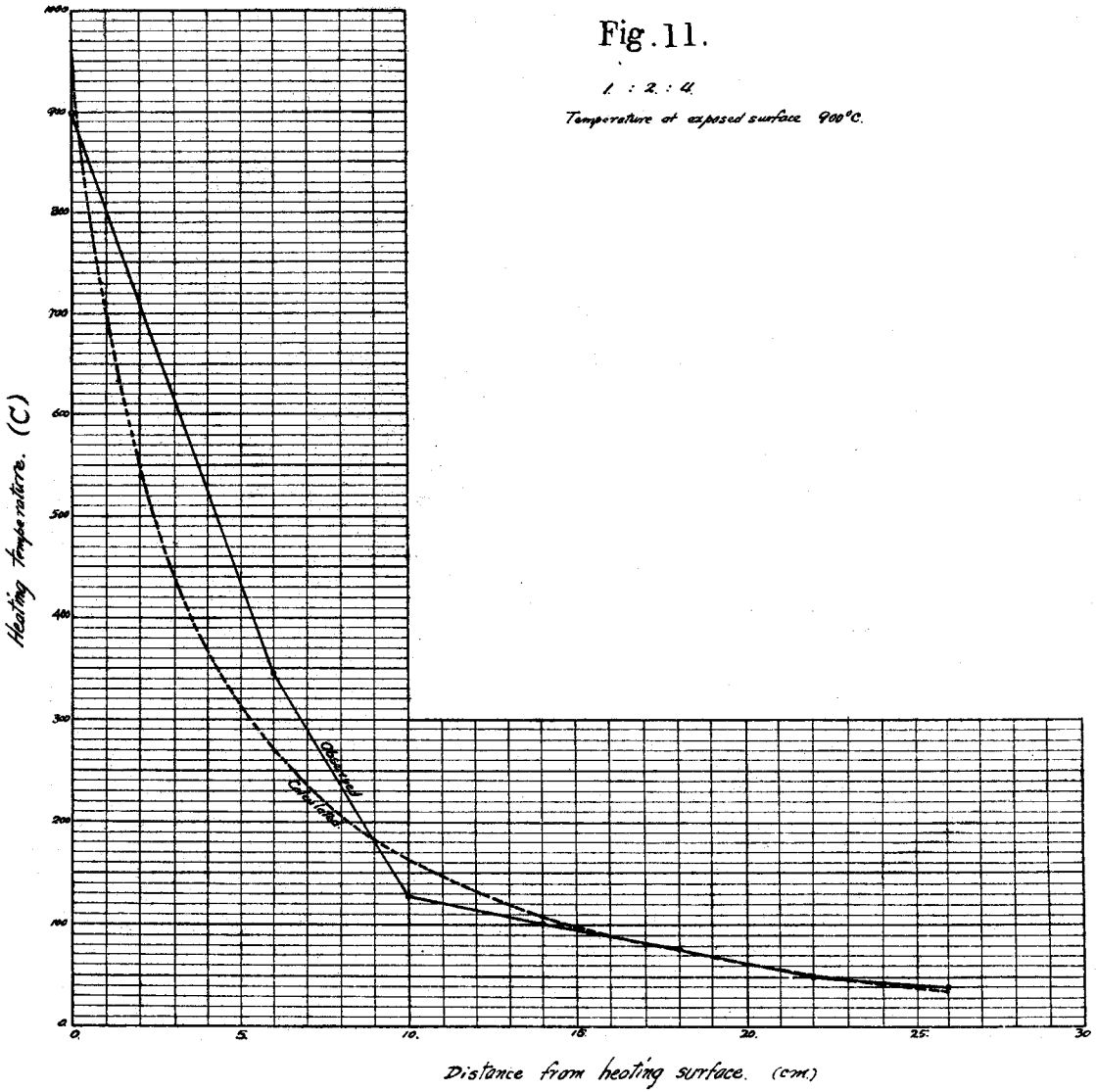

Fig.12

1:3:6.

Temperature at exposed surface. 900°C.

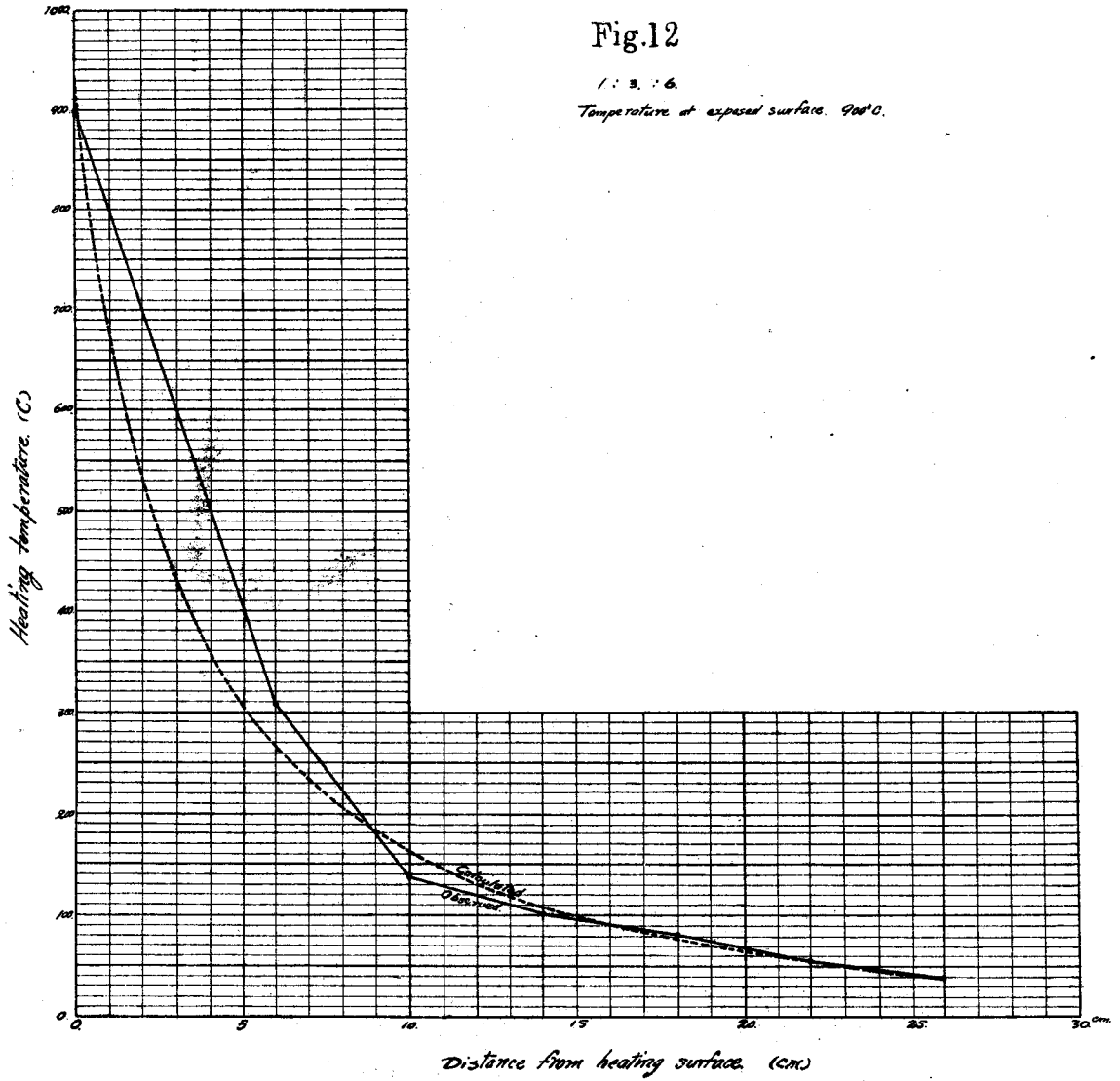

Fig. 13.

1 : 4 : 8.
Temperature of exposed surface 900°C.

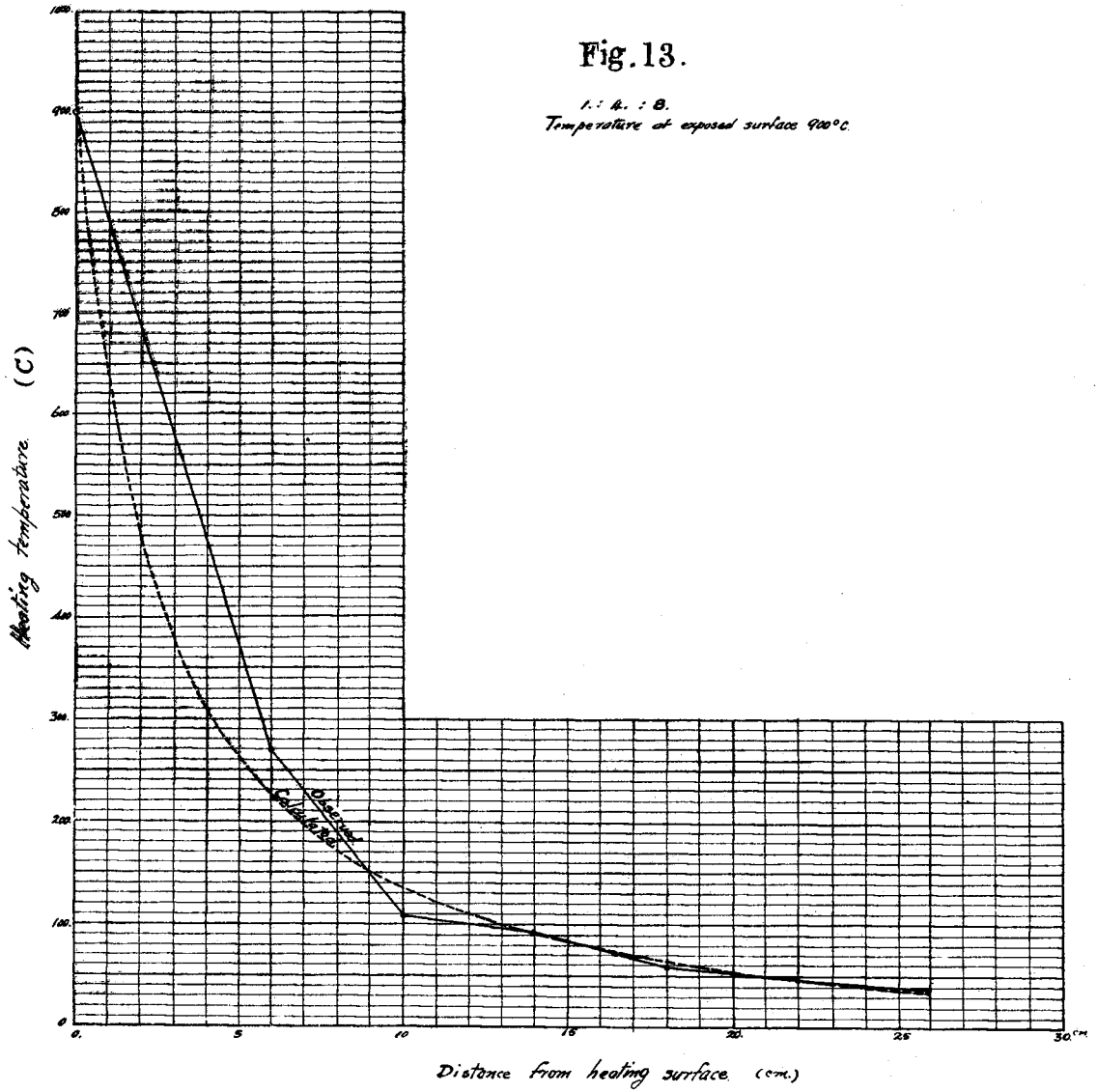

Fig. 14.

1 : 2 : 4
Temperature of exposed surface 500°C.

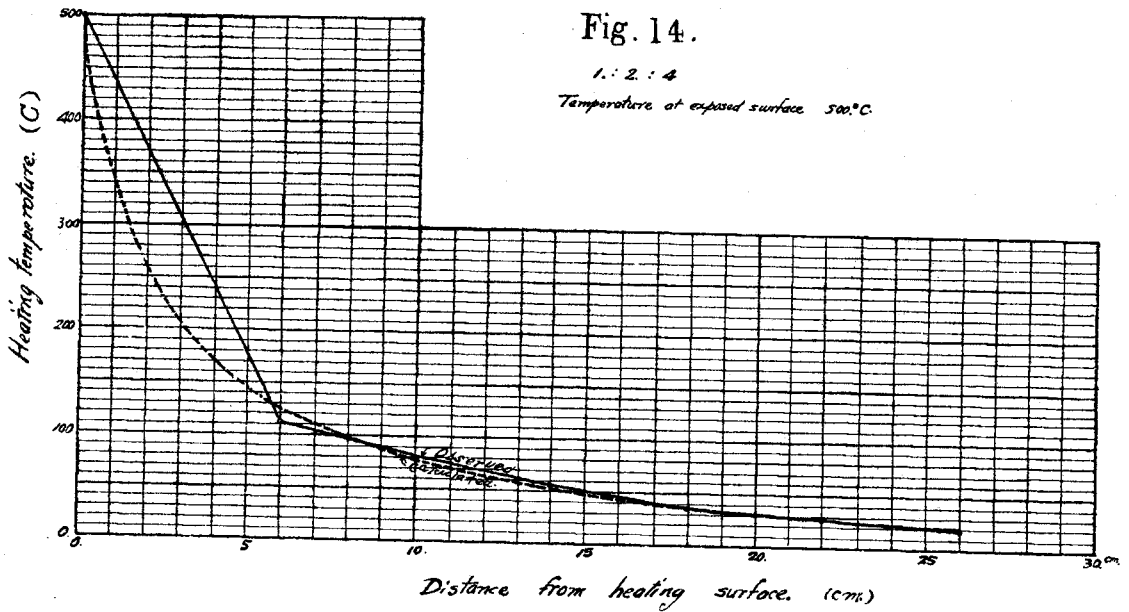
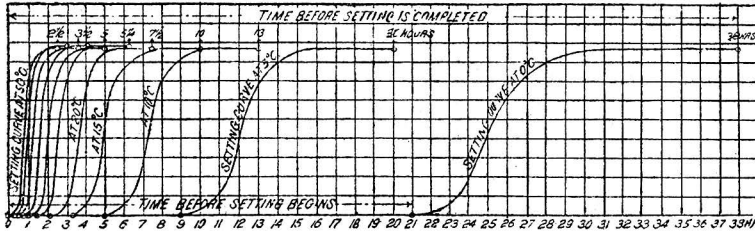
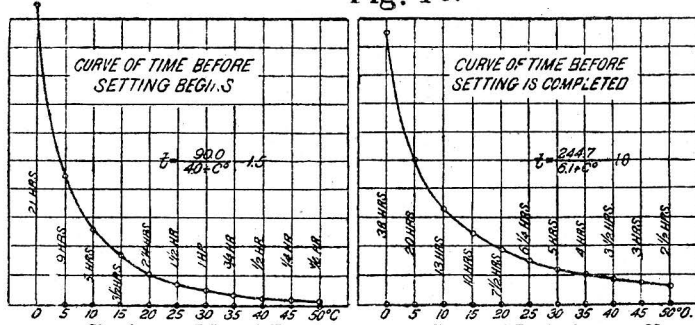

Fig. 14.



Graphical Representation of the Rate of Setting of Portland Cement at Various Temperatures

Fig. 15.



Showing the Effect of Temperature on the Setting of Portland-cement Mortar 1 C.:3 S. The temperature is given in degrees centigrade. (Tetmajer's Communications, vol. vi, Plate VIII.)

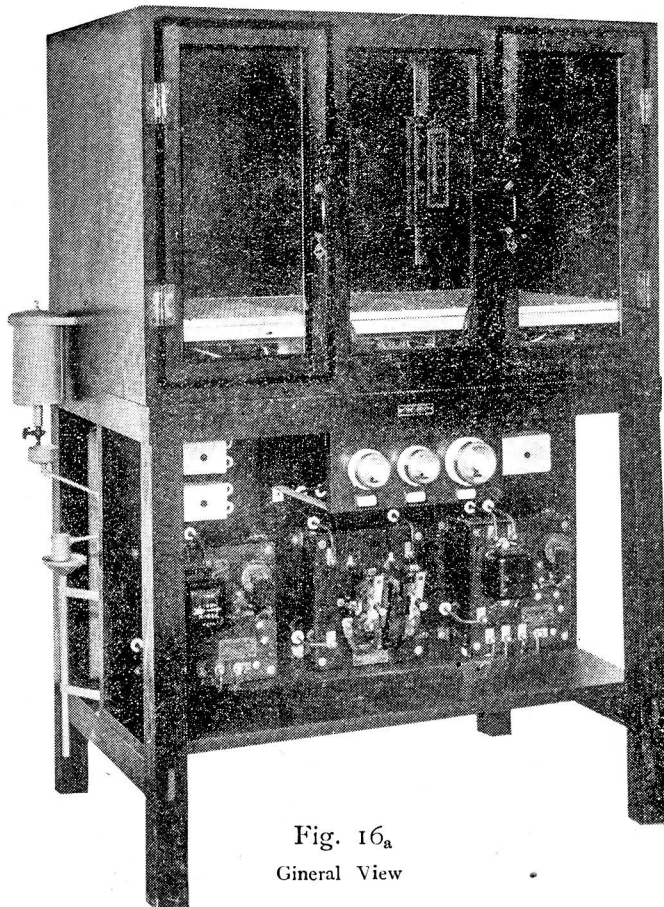
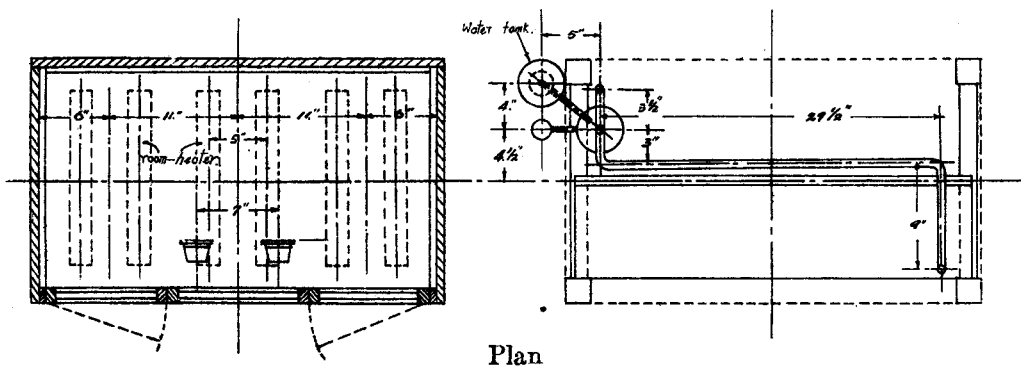
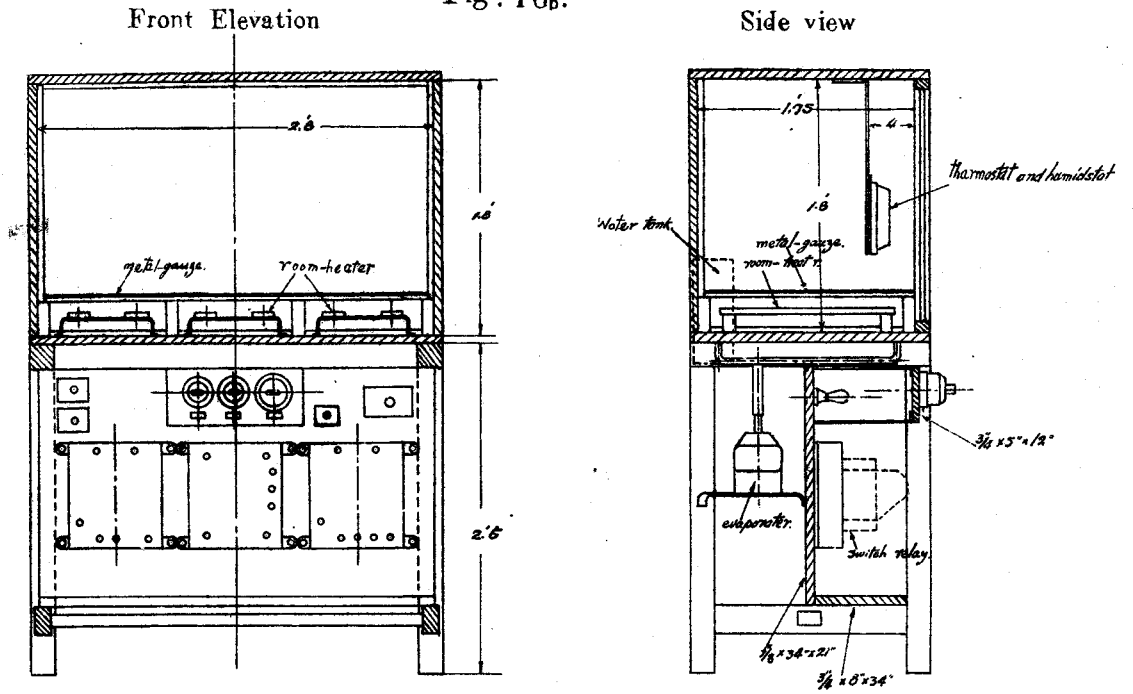

Fig. 16_a
General View

Fig. 16b.



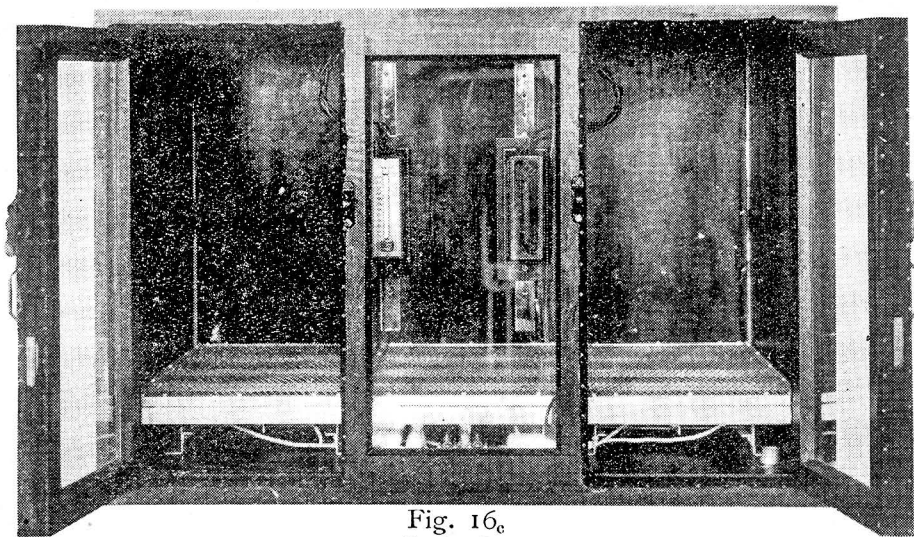

Fig. 16_e
Testing box.

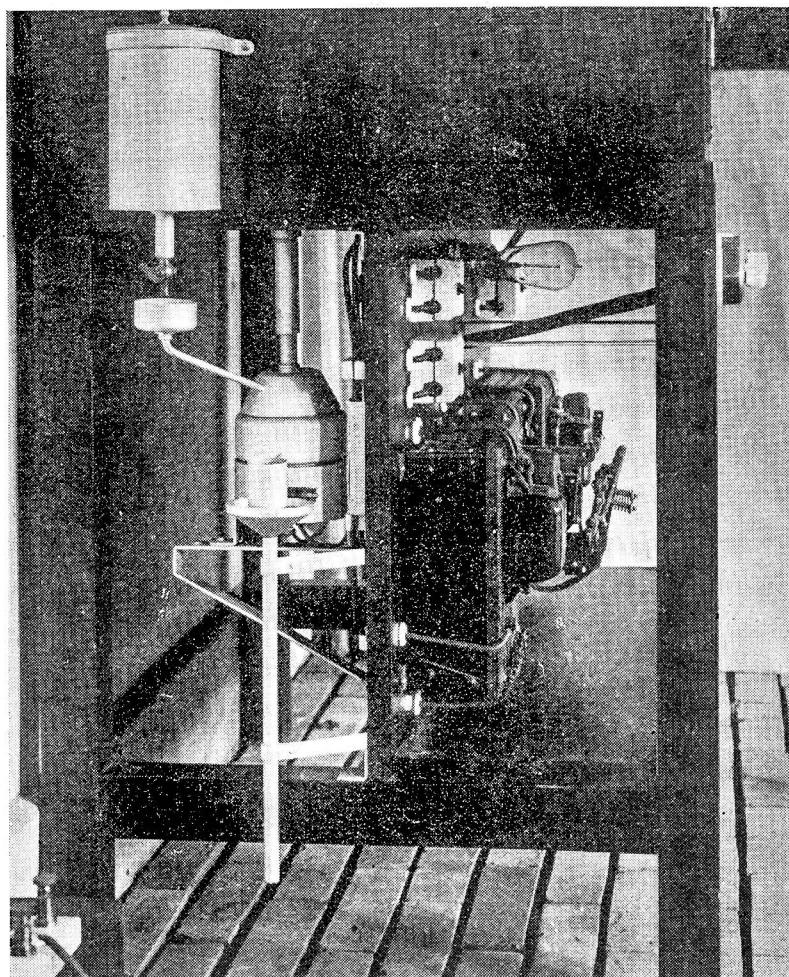

Fig. 16_a
Water tank, evaporator and switch relay.

Fig. 17a

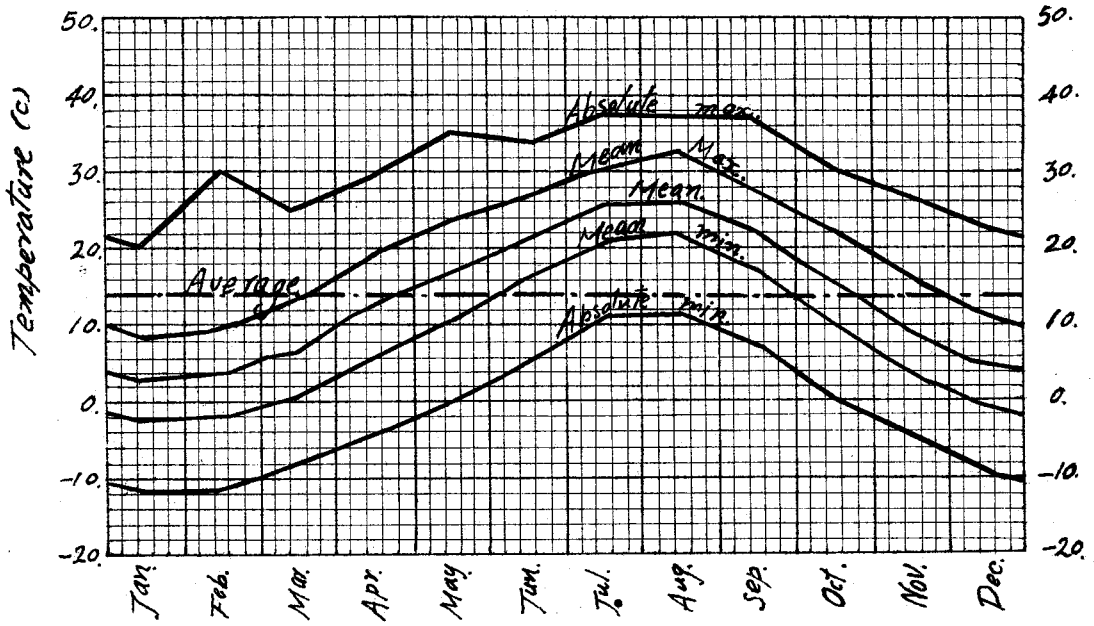

Fig. 17b

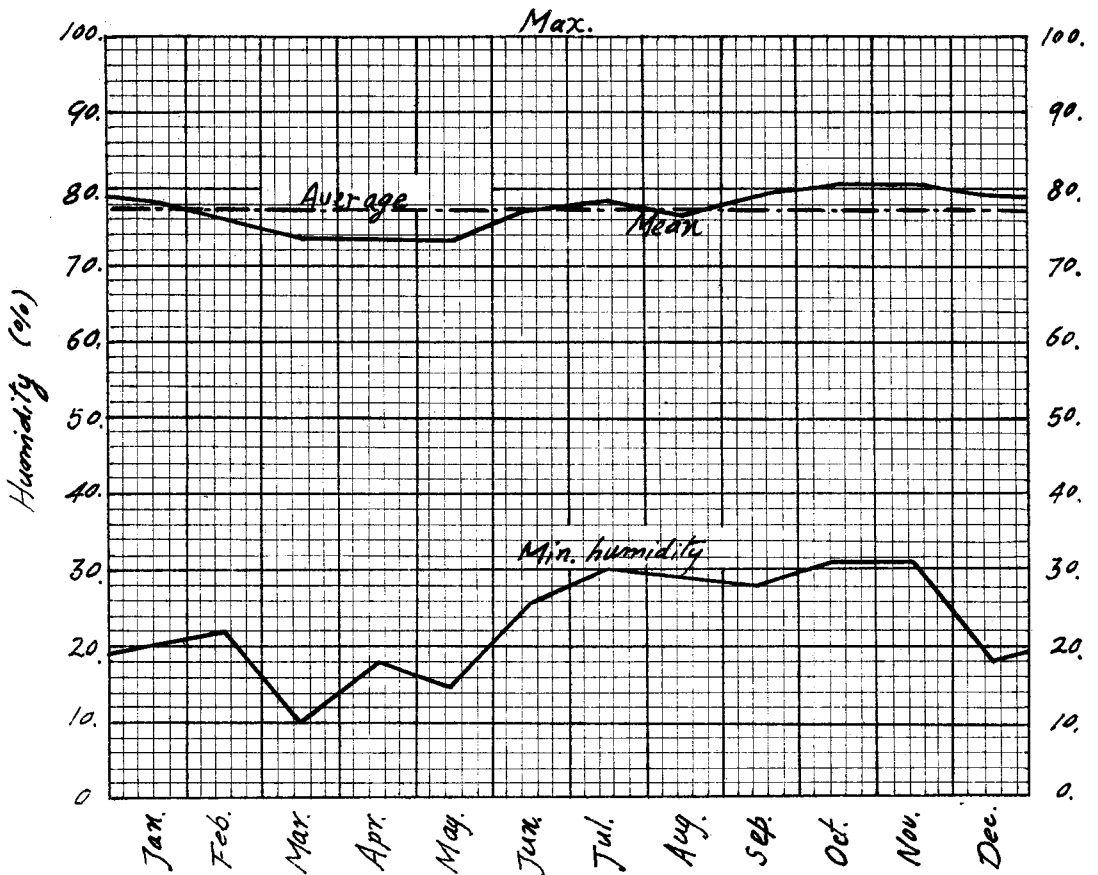

Fig. 18

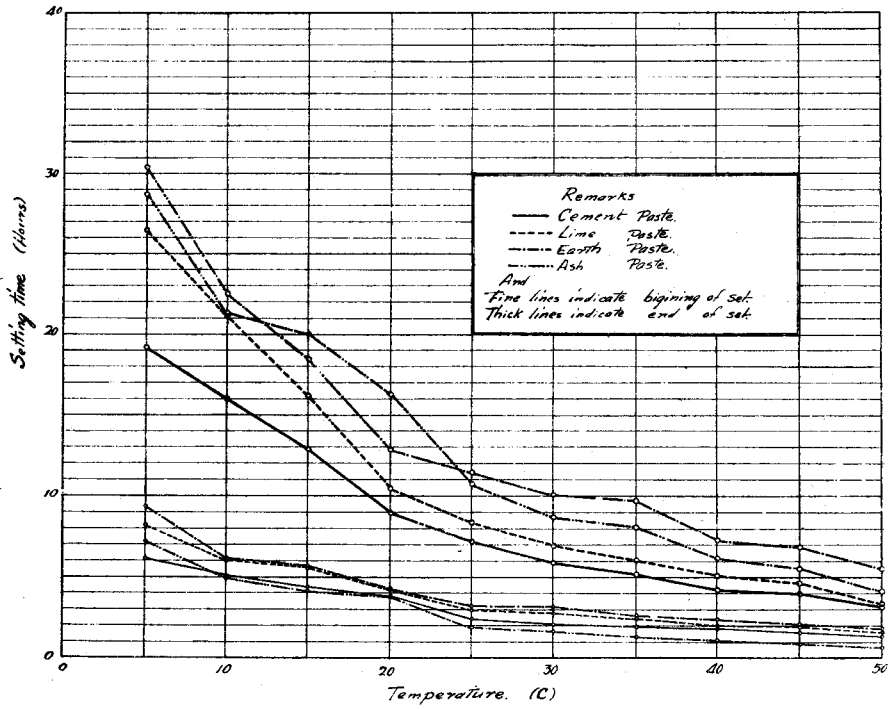

Fig. 19a
 Cement paste.

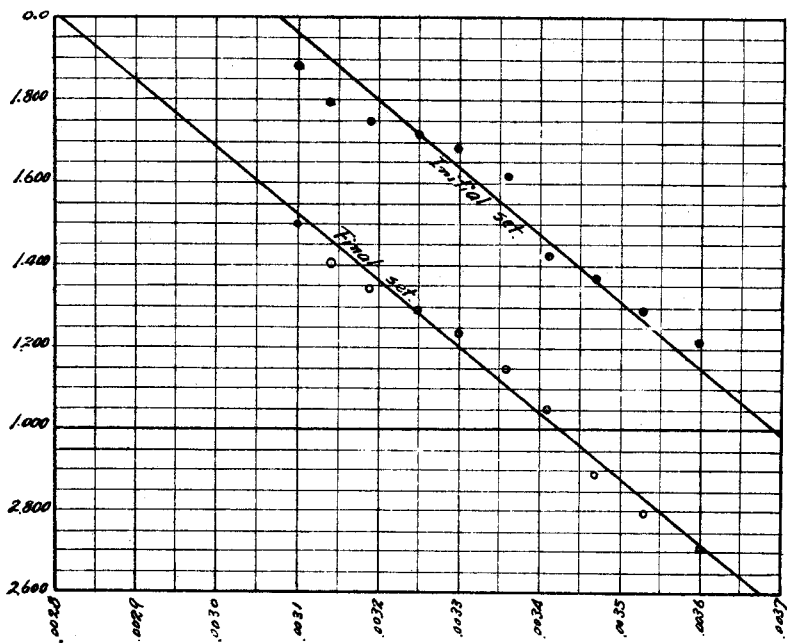

Fig. 19b
Lime paste

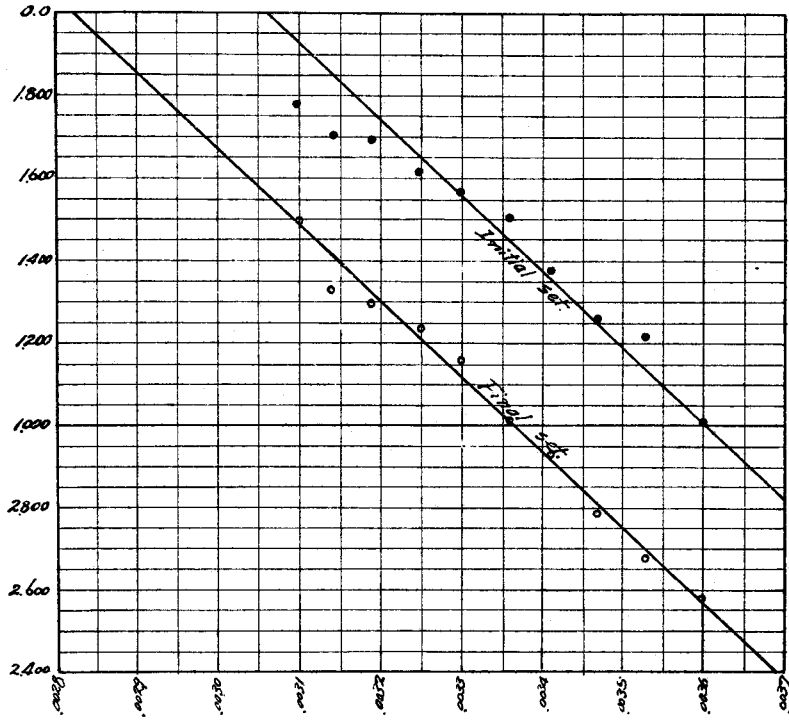

Fig. 19c
Ash paste

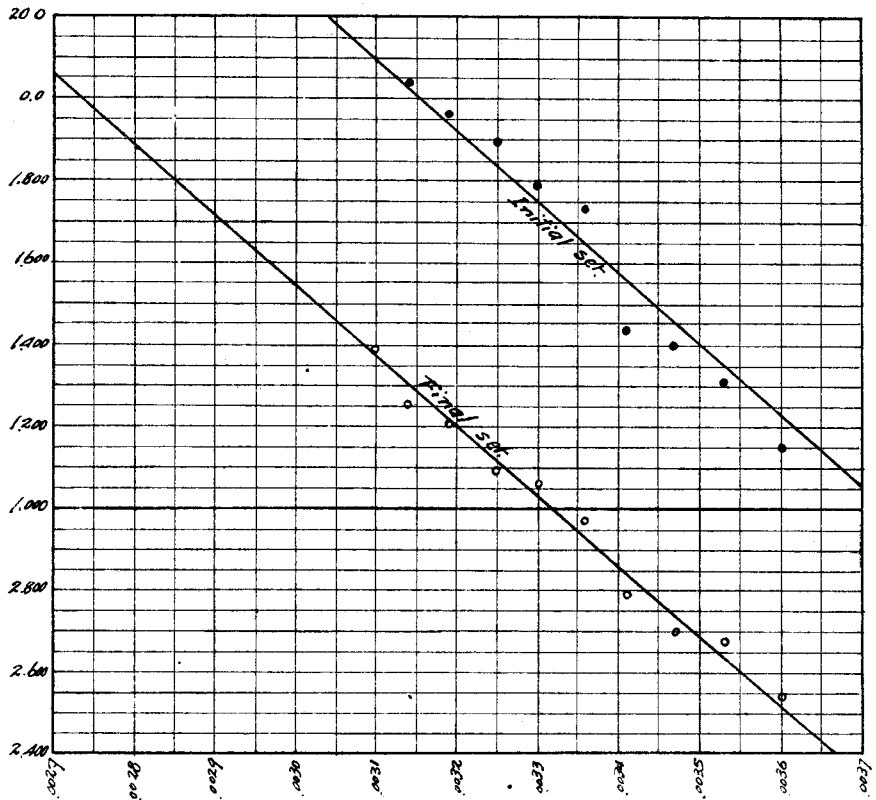

Fig. 19d
Earth paste.

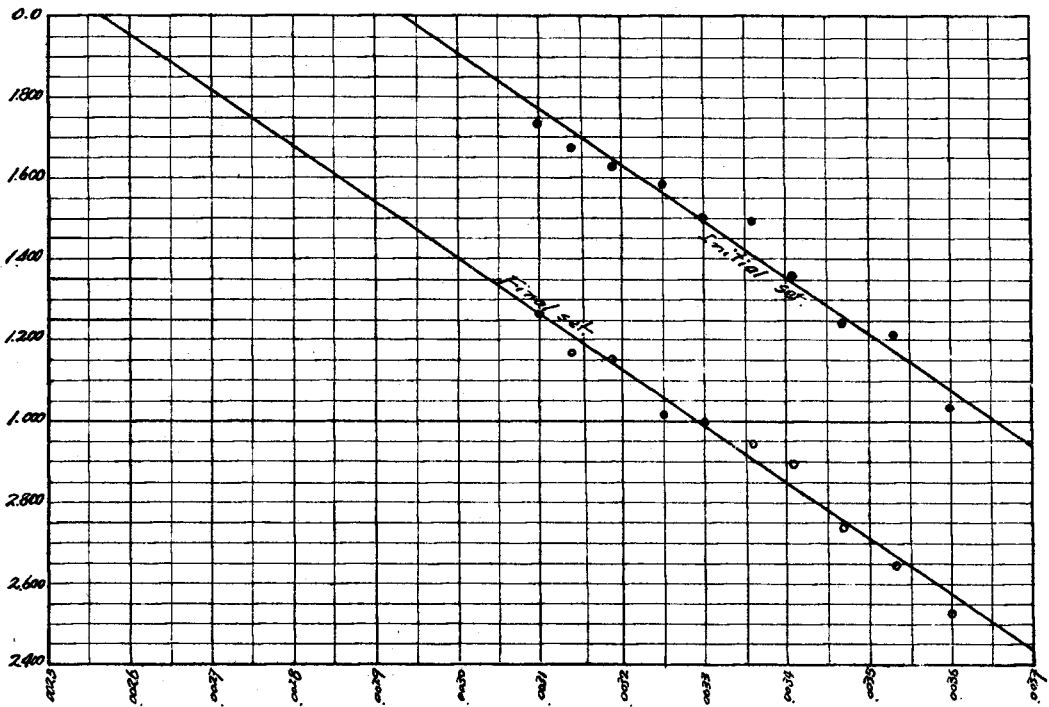
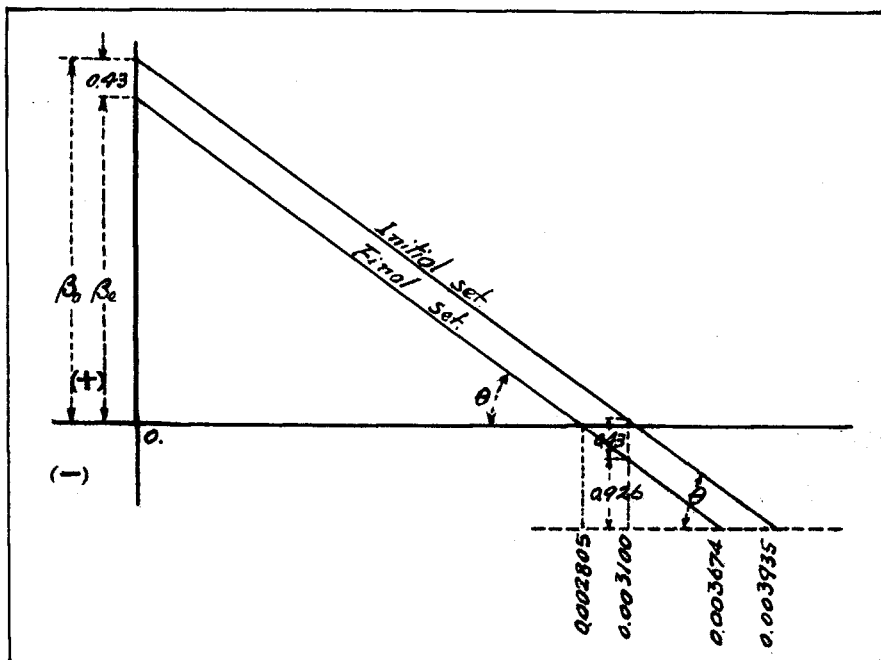
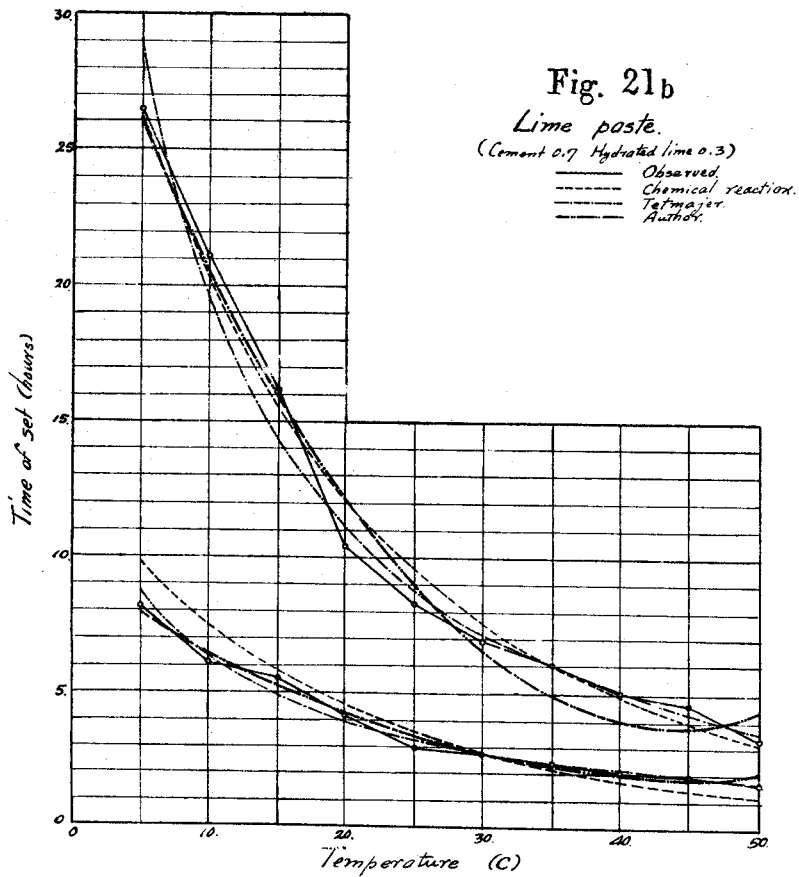
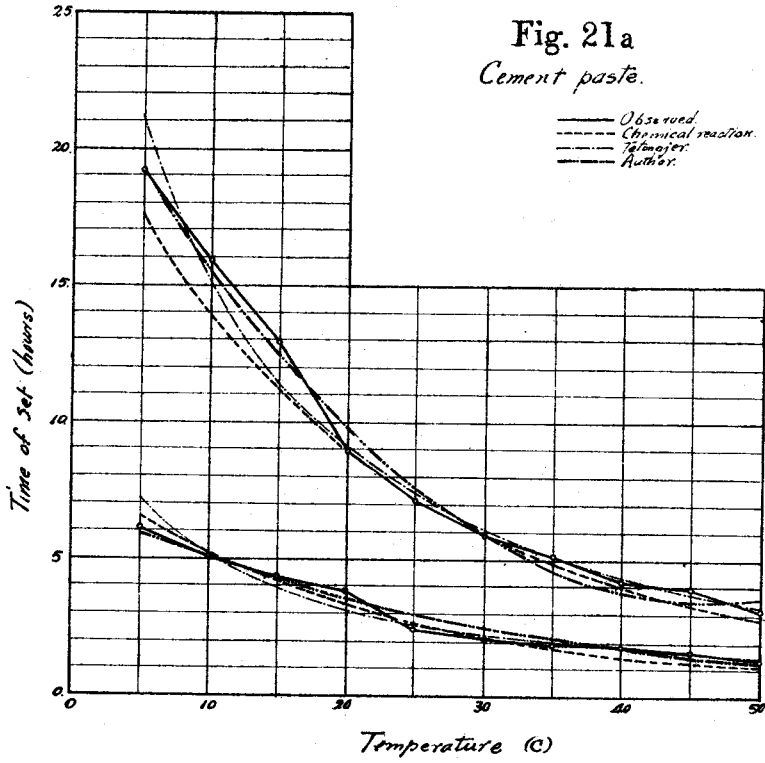

Fig. 20





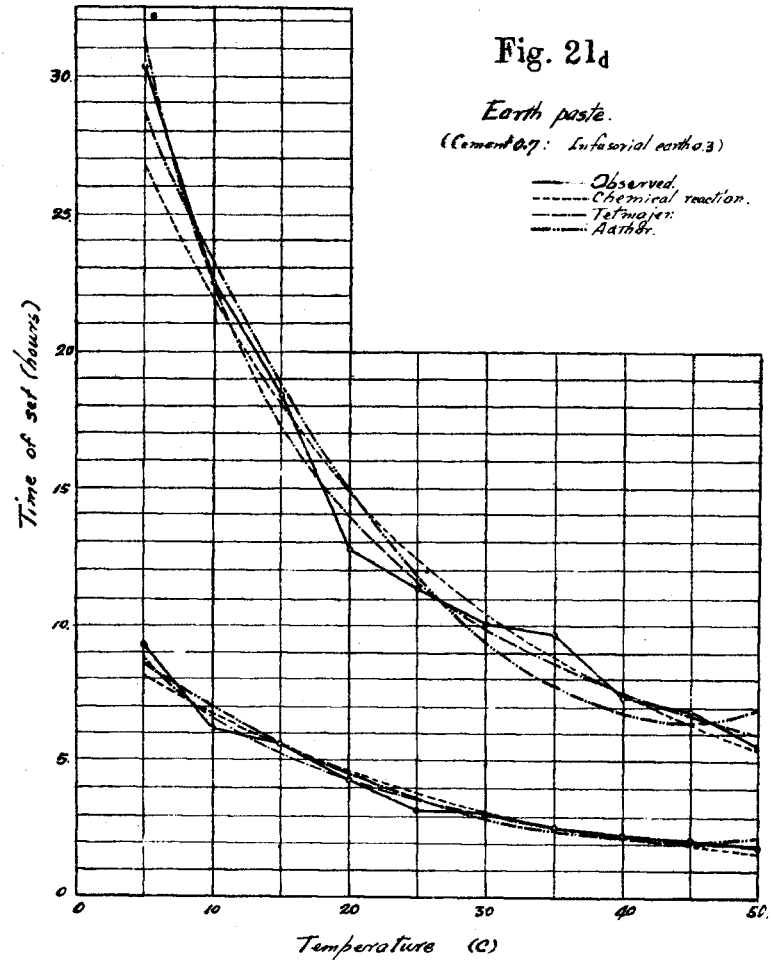
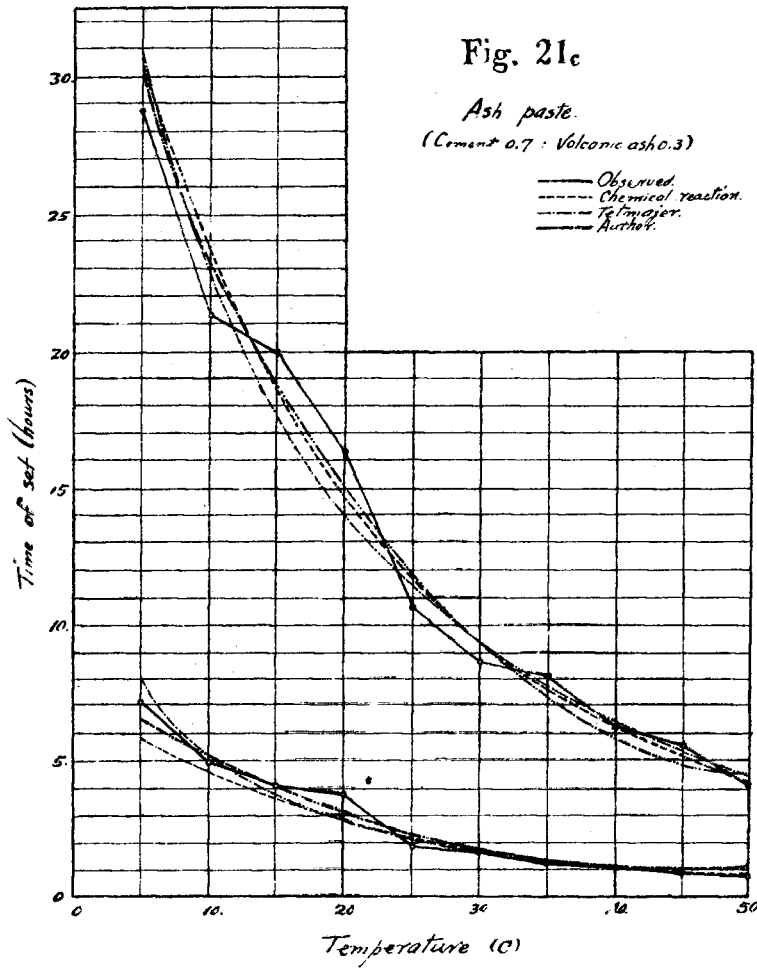

Fig. 22

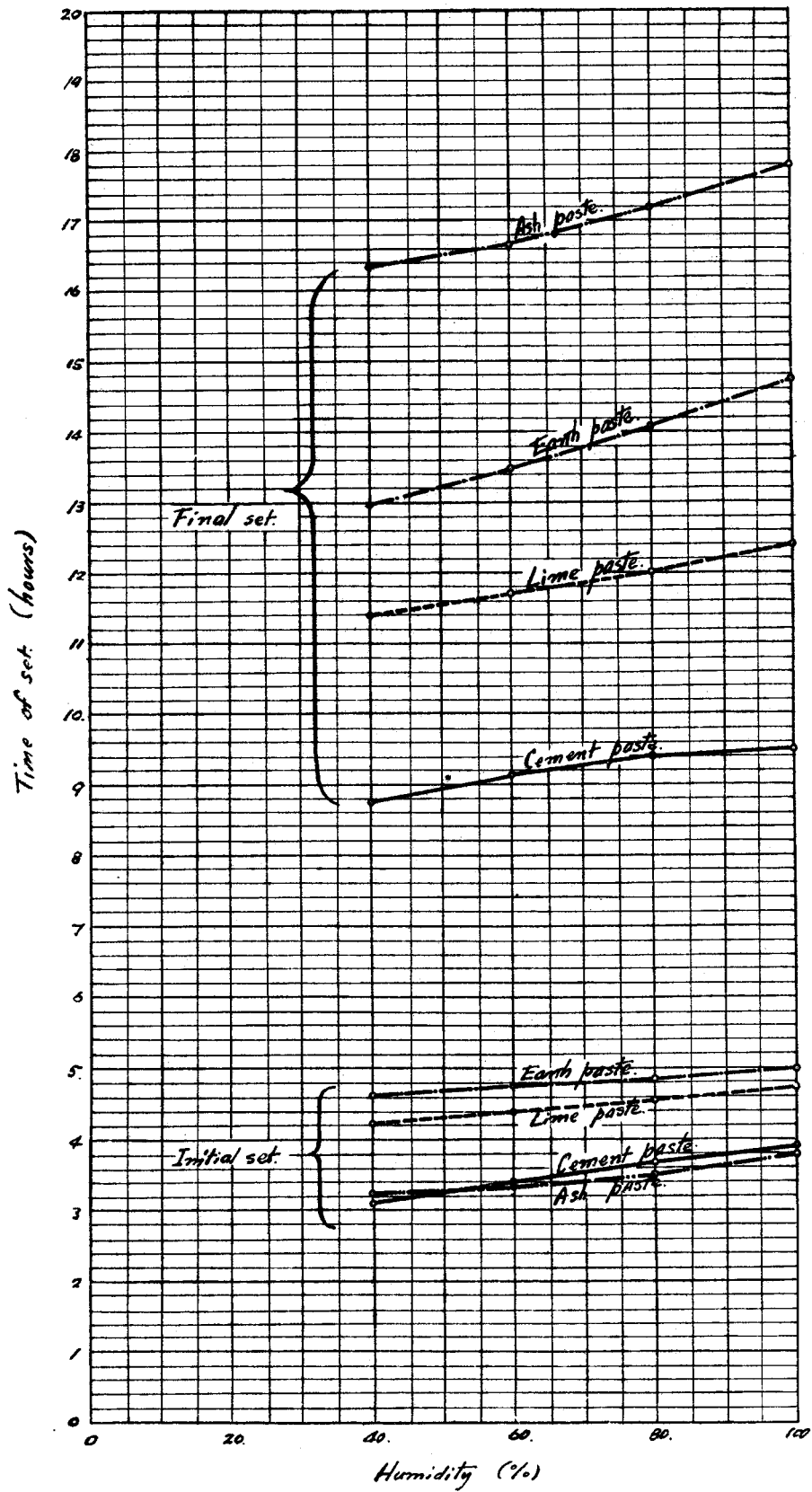

Fig. 23

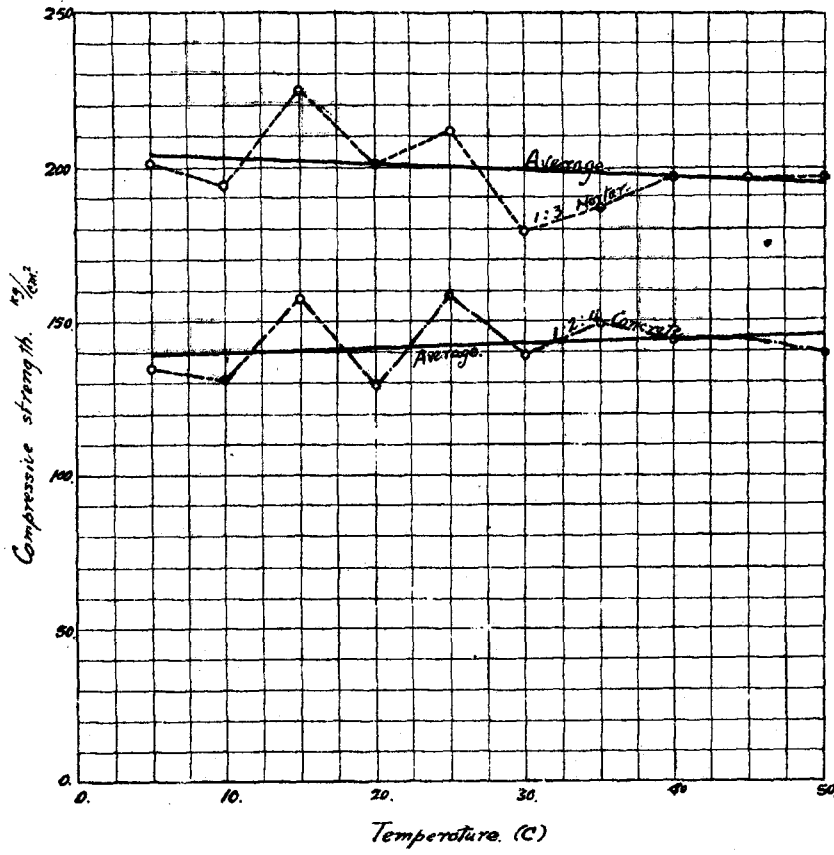

Fig. 24

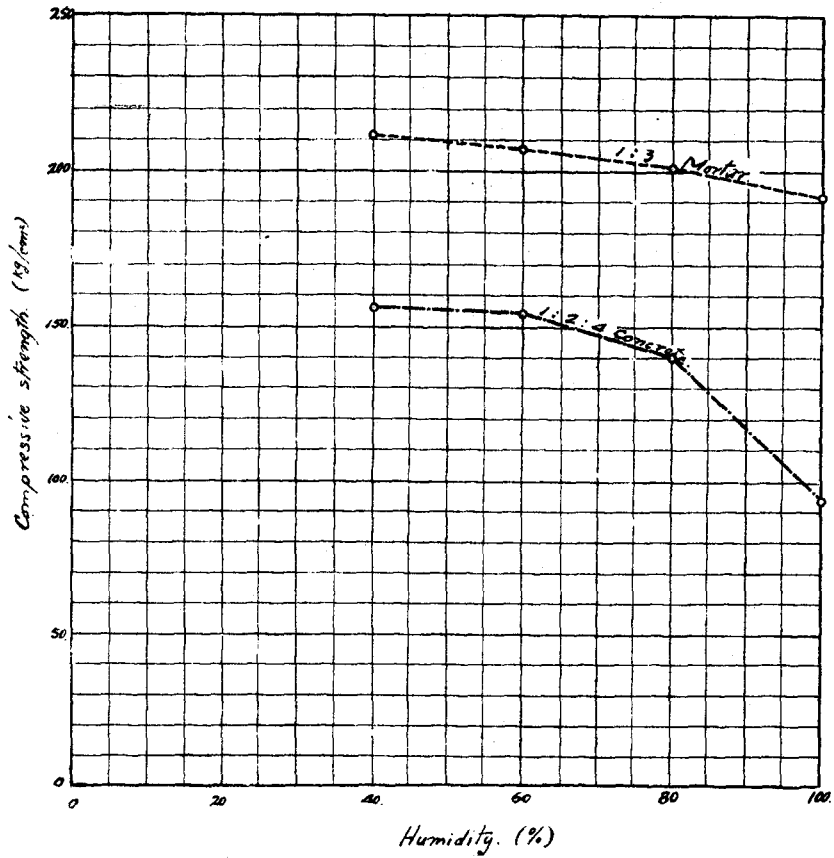

Fig. 25.

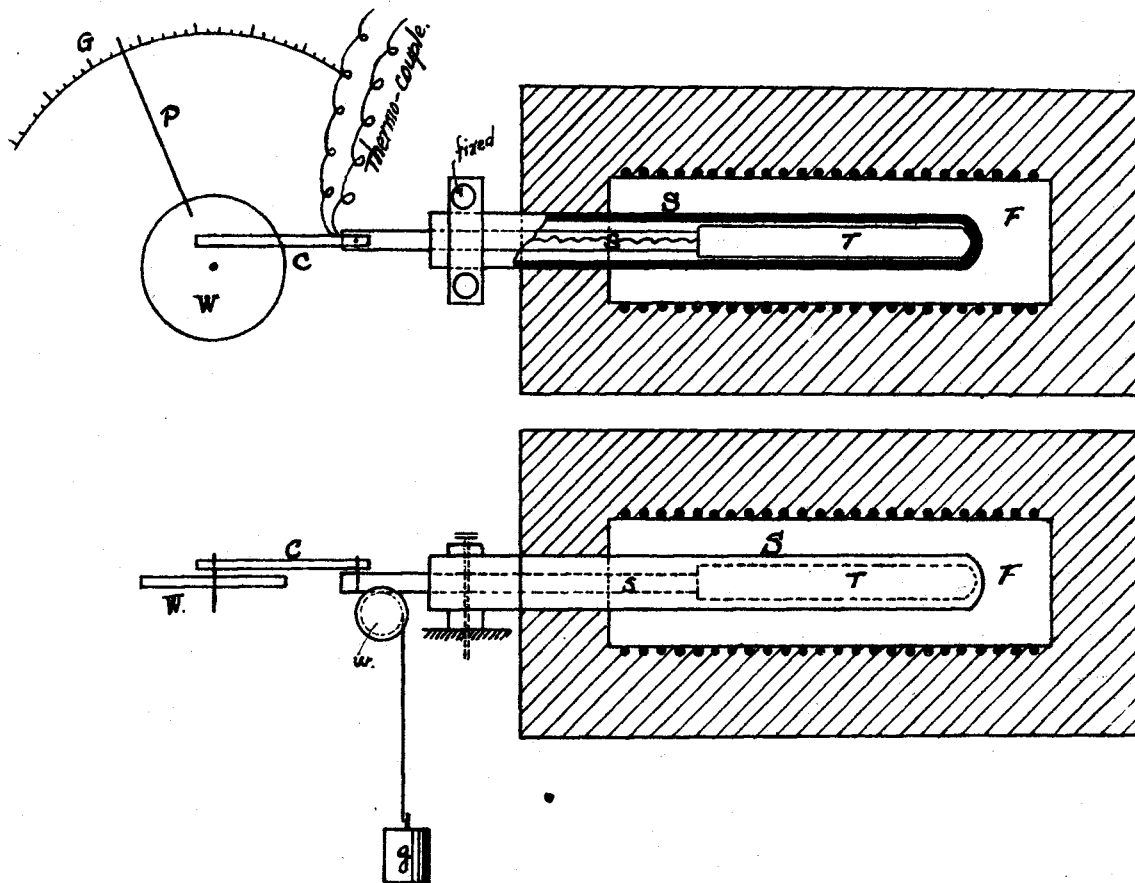

Fig.26a.

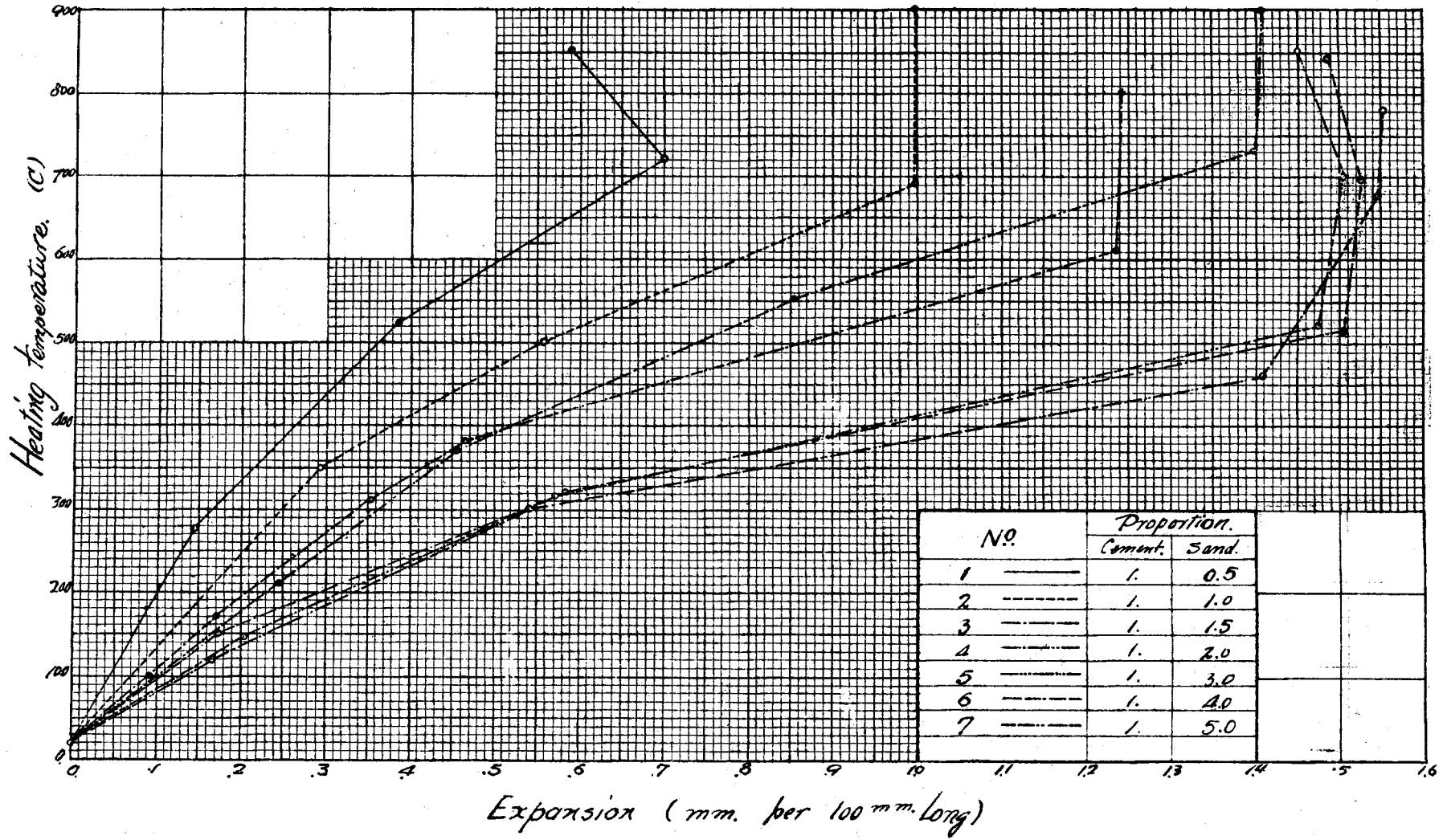

Fig. 26b.

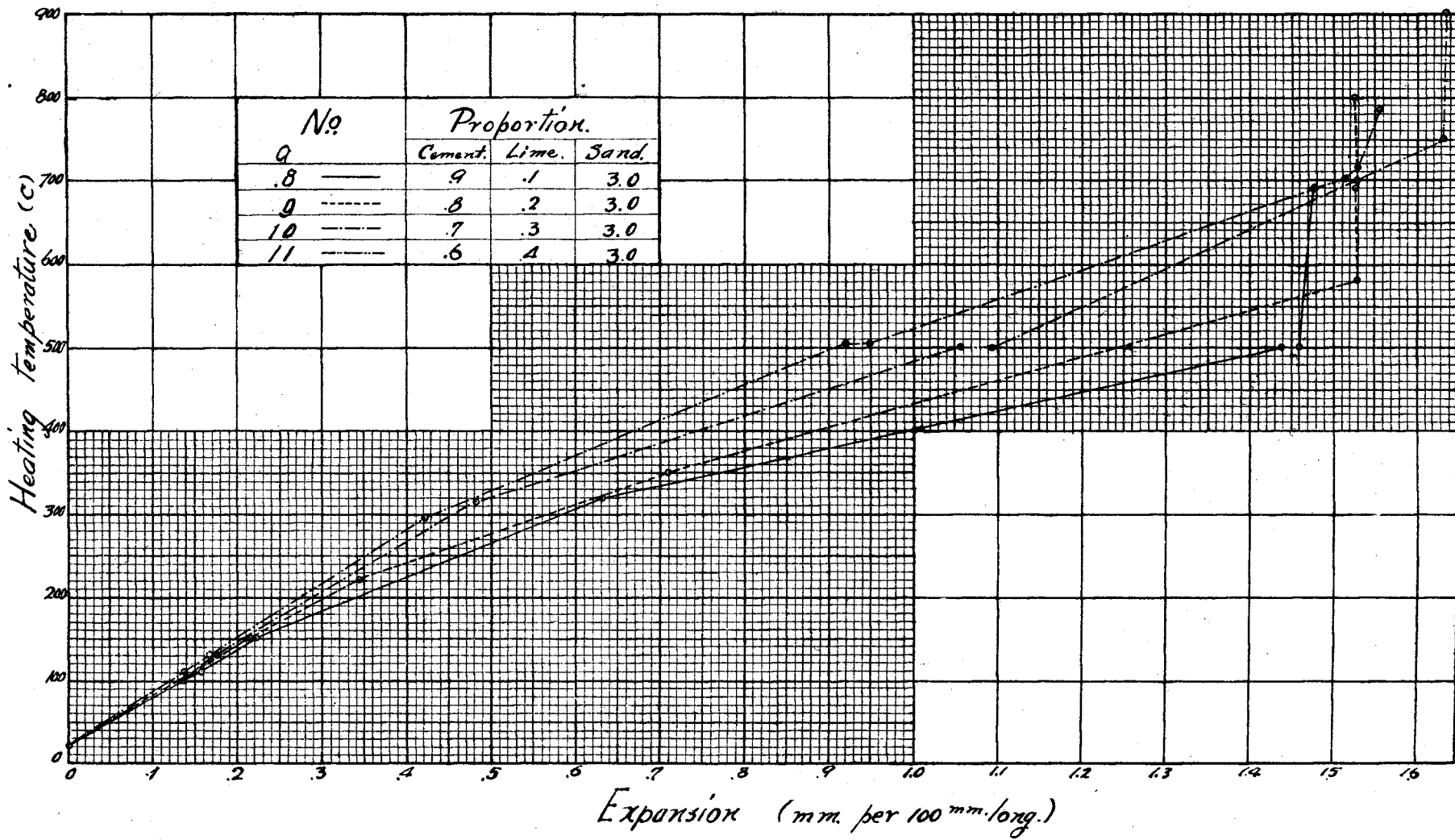

Fig. 26c.

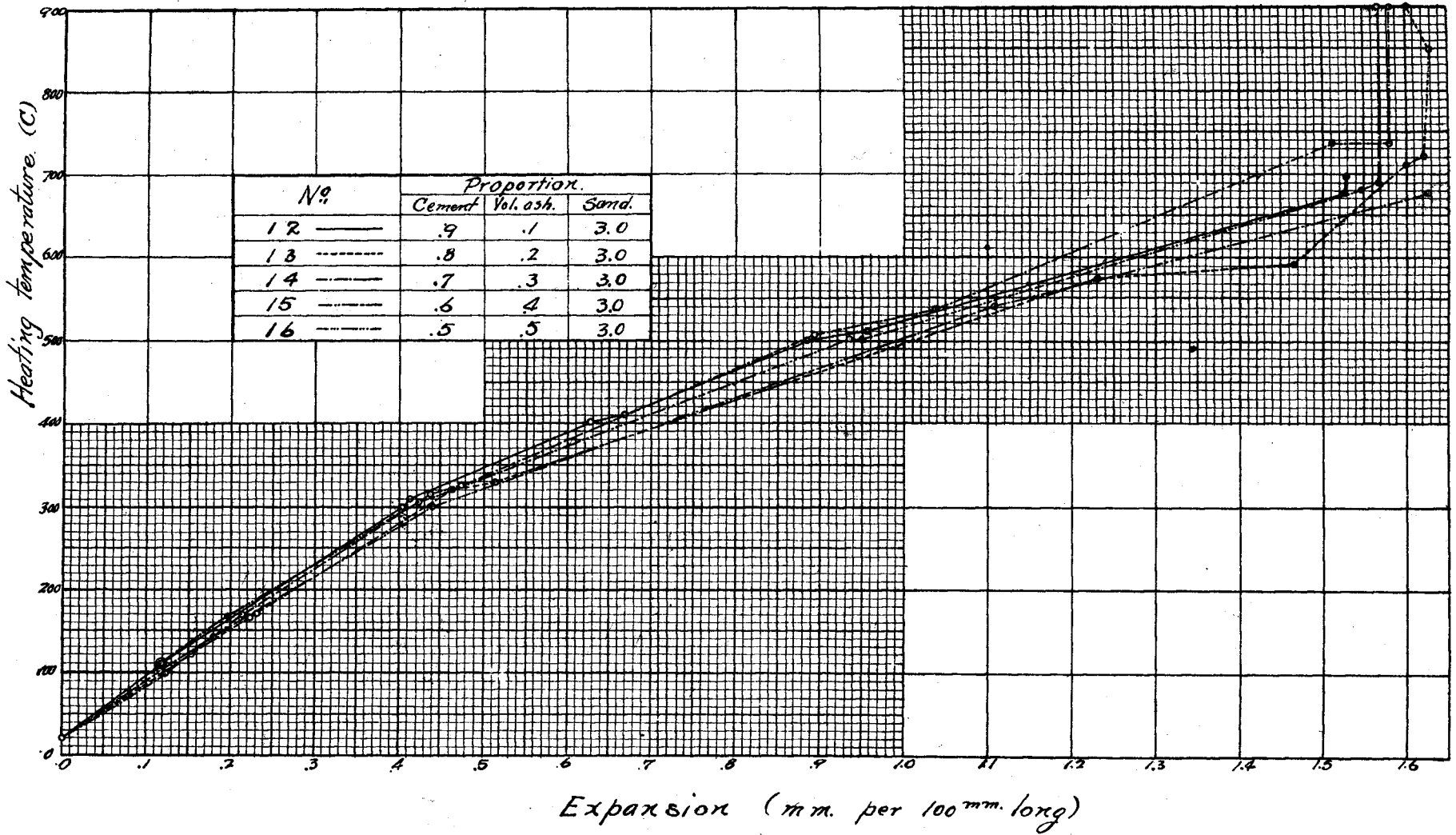

Fig. 26a.

