



TITLE:

# Tear-figures on Certain Minerals IV

AUTHOR(S):

Kuhara, Mikio

---

CITATION:

Kuhara, Mikio. Tear-figures on Certain Minerals IV. Memoirs of the College of Engineering, Kyoto Imperial University 1918, 2(3): 71-82

ISSUE DATE:

1918-11-12

URL:

<http://hdl.handle.net/2433/280033>

RIGHT:

## Tear-figures on Certain Minerals. IV.

By

**Mikio Kuhara.**

In the previous papers<sup>1</sup>, the tear-figures on the minerals belonging to the regular, rhombic, hexagonal and monoclinic systems were discussed, in the following articles the author desires to explain the characteristics of those on crystals of the tetragonal and triclinic systems. For this purpose, the author has selected wulfenite and copper-sulphate crystals as the representatives of the minerals belonging to the two systems.

### Wulfenite.

The specimen under examination was a translucent thin-platey crystal spreading parallel to the basal pinacoid and showing faces  $\{110\}$  and  $\{001\}$ . H-2. 7-3; brittle; cleavage good pyramidal; system tetragonal.

A basal pinacoid was polished and a light percussion of a needle-point was applied on it. A tear-figure on this face is a square with sides slightly curved giving the figure a rounded appearance (PL. XXIV, Fig. 1a, b and d). The sides of the square are parallel to  $\{100\}$ . The square figure, in the centre, has crossed cracks each of which is paral-

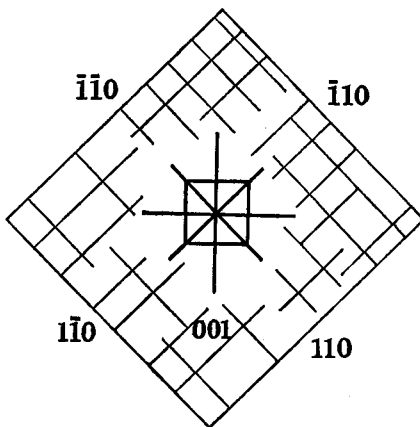

Fig. 29.

1) Mikio Kuhara, "Tear-figures on Certain Minerals. I-III." These Memoirs, Vol. I, No. 8, pp. 267-74, 1916; Vol. I, No. 10, pp. 279-86, 1917; and Vol. II, No. 2, pp. 53-62, 1918.

lateral to the sides of the square (PL. XXIV, Fig. 1a, b and d). This is the form commonly produced. Sometimes the diagonal cracks bisecting the angles between the crossed cracks and parallel to  $\{110\}$  are observed. From the foregoing, the perfect figure is assumed to be a square with four cracks (Fig. 29) of which the two parallel to  $\{100\}$  are always distinct while the others are indistinct or missive. The primitive figure has various shapes (Fig. 30), among which a single cross is most common (PL. XXIV, Fig. 1c, e and Fig. 2b).

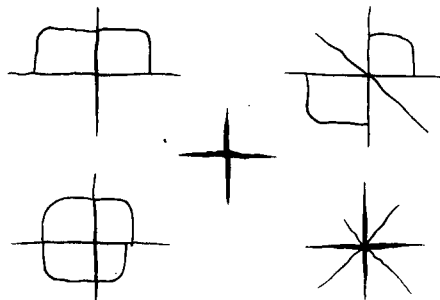

Fig. 30.

The various shapes of the imperfect figure.

### Copper-sulphate.

The examined specimen was an artificial crystal developing the faces  $\{1\bar{1}0\}$ ,  $\{110\}$ ,  $\{100\}$ ,  $\{010\}$  and  $\{111\}$  on which the tear-figures were studied.

H-2.5, cleavage  $\{1\bar{1}0\}$ ,  $\{110\}$ , and  $\{111\}$  imperfect; brittle; system triclinic. The tear-figures were produced with a very light pressure or percussion of a needle-point.

On  $(110)$ , the perfect tear-figure consists of four cracks (Fig. 31 and Fig. 1b, PL. XXV) of which  $\alpha$  is  $90^\circ$  to the edges between  $(010)$  and  $(1\bar{1}0)$  or  $(100)$  and  $(1\bar{1}0)$ . The angles between the other cracks and  $\alpha$  are as follows:

$\alpha$  and  $\beta$ ..... $44^\circ$

$\alpha$  and  $\gamma$ ..... $77^\circ$  approximately parallel to the edges between

$\alpha$  and  $\delta$ ..... $111^\circ$   $(010)$   $(1\bar{1}0)$  or  $(100)$   $(1\bar{1}0)$ .

- The imperfect figures are composed of a less number of cracks. The various shapes, of which the form (a) is common, are shown in Fig. 32 and Fig. 1, PL. XXV.

On  $(110)$ , the tear-figure is turned  $180^\circ$  around the  $b$ -axis.

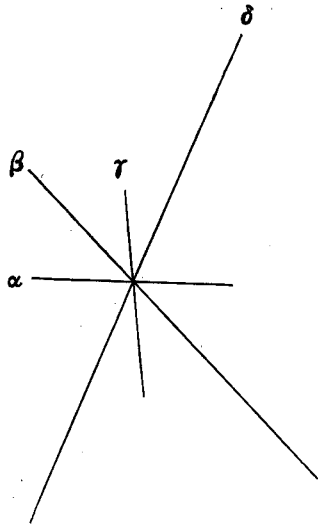

Fig. 31.

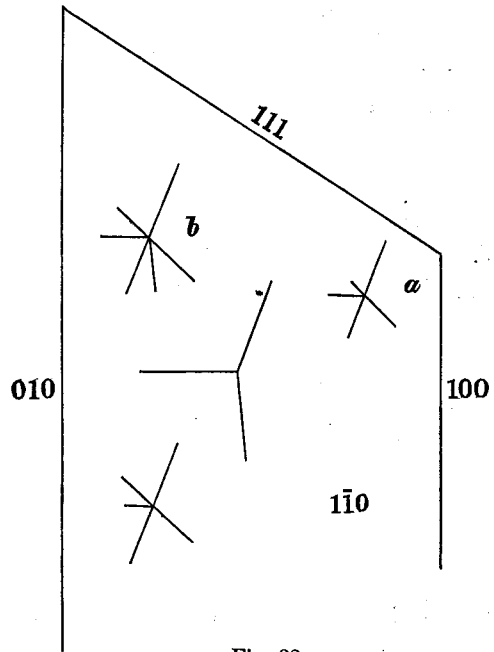

Fig. 32.

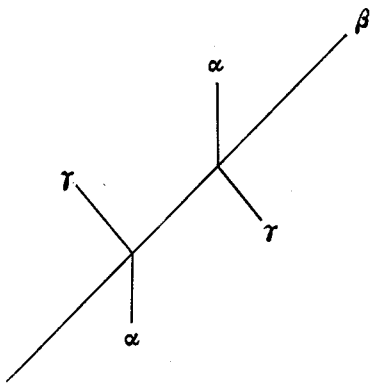

Fig. 33.

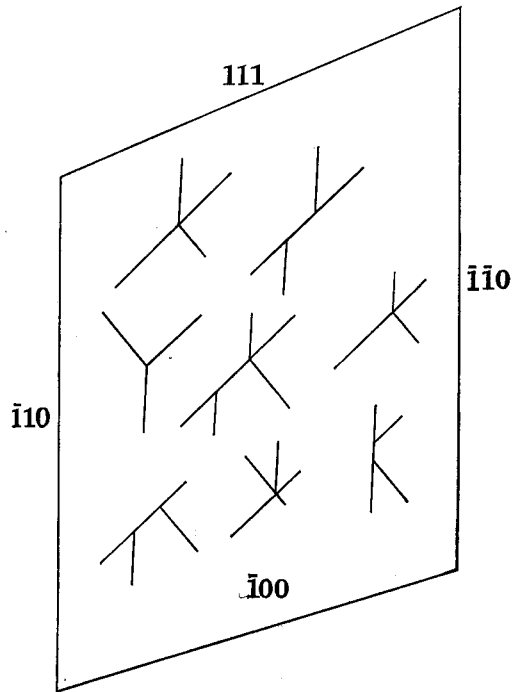

Fig. 34.

On  $(\bar{1}00)$ , a perfect figure is composed of the cracks of three directions and has the shape shown in Fig. 33 and Fig. 2a, PL. XXV. The angles between  $\alpha$  and the other cracks are as follows:

$$\alpha \text{ and } \beta \dots\dots\dots 45^\circ$$

$$\alpha \text{ and } \gamma \dots\dots\dots 140^\circ$$

$\beta$  is always the longest. The various shapes of the imperfect tear-figures are shown in Fig. 34.

On  $(100)$ , the tear-figure is turned  $180^\circ$  around the  $b$ -axis.

On  $(111)$ , the perfect figure is composed of the five cracks (Fig. 35 and Fig. 1a, PL. XXVI). The angles between  $\alpha$  and the others are as follows:

$$\alpha \text{ and } \beta \dots\dots\dots 23^\circ$$

$$\alpha \text{ and } \epsilon \dots\dots\dots 120^\circ$$

$$\alpha \text{ and } \gamma \dots\dots\dots 83^\circ$$

$$\alpha \text{ and } \delta \dots\dots\dots 141^\circ$$

$\alpha$  being parallel to  $\{100\}$ ,  $\beta$  to  $\{1\bar{1}0\}$  and  $\epsilon$  to  $\{010\}$ . The imperfect figures are shown in Fig. 2, PL. XXVI. Fig. 36a and Fig. 1b, PL. XXVI

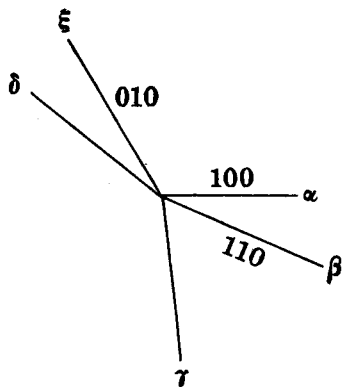

Fig. 35.

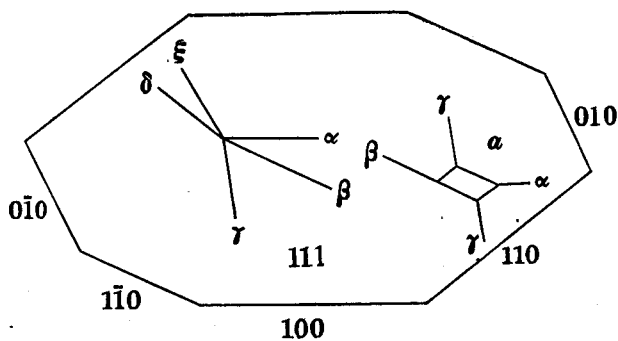

Fig. 36.

show an imperfect form consisting of a rhombic figure and four rays. The sides of the central rhomb are parallel to  $\{1\bar{1}0\}$  and  $\{110\}$ , and two of the rays to  $\{1\bar{1}0\}$  and  $\{100\}$ , but other two are indeterminable.

On  $(010)$ , the perfect tear-figure is a starlike form with five cracks one of which,  $\alpha$ , is parallel to  $(111)$  (Fig. 37 and Fig. 1, PL. XXVII). The angles between  $\alpha$  and other cracks are as follows:

$\alpha$ and $\beta$ .....	$25^\circ$	$\alpha$ and $\delta$ .....	$82^\circ$
$\alpha$ and $\gamma$ .....	$57^\circ$	$\alpha$ and $\epsilon$ .....	$124^\circ$

The imperfect figure has two or three cracks (Fig. 38 *a* and *b*; Fig. 2 *a* and *b*, PL. XXVII).

Every Tear-figure on this crystal is asymmetrical even as the crystal itself; but certain cracks or sides of it, in most cases, are parallel to certain faces

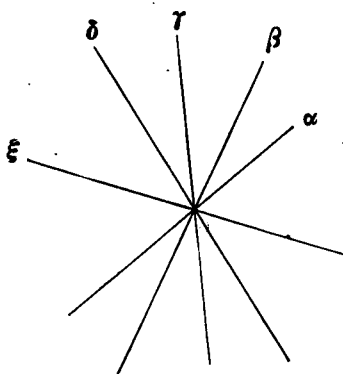

Fig. 37.

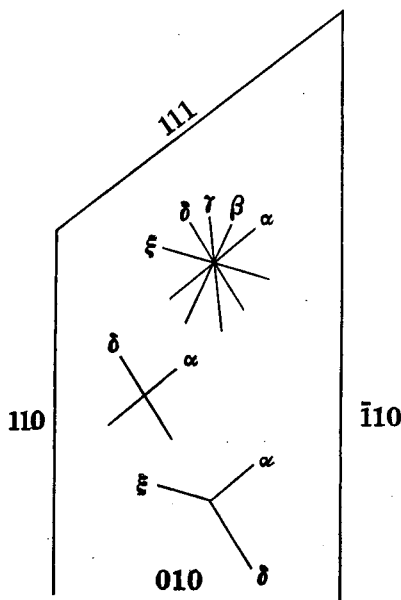

Fig. 38.

which bound the host face. To denote, therefore, the directions of the cracks which are not certain to what face they are parallel, the author shows the angles from a determined crack.

### Supplementary Notes.

#### STIBNITE.

On (010), a complete tear-figure is assumed to be an hour-glass shaped one which is composed of the inverted and upright isosceles triangles. Thus, the symmetry of the figure is quite concordant with that of the crystal (Fig.39).

#### VIVIANITE.

By a close investigation of a tear-figure on (010) of vivianite with perfect terminations, the upper side of the triangle is parallel to ( $\bar{1}01$ ) and the

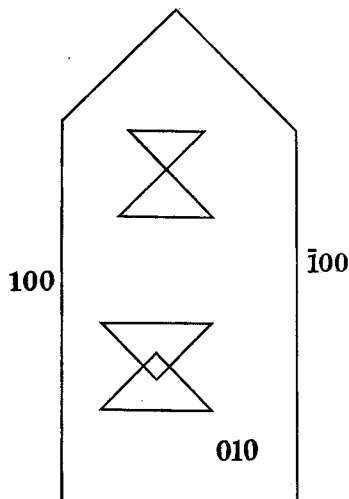

Fig. 39.

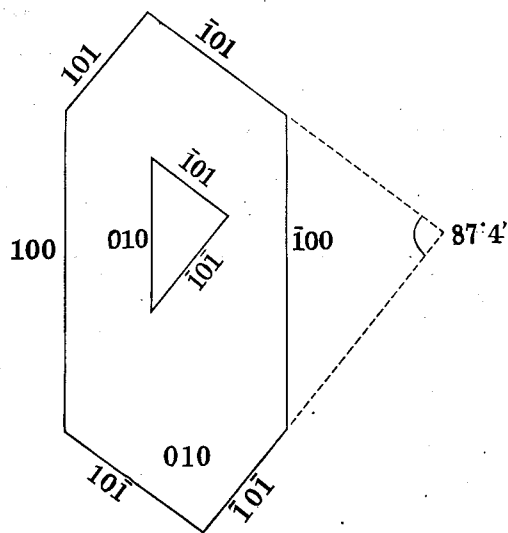

Fig. 40.

lower to  $(\bar{1}0\bar{1})$ . The apical angle of the figure is little smaller than  $90^\circ$ , which is approximately equal to the angle between  $(\bar{1}01)$  and  $(\bar{1}0\bar{1})$  (Fig. 40).

### The Inclination of the sides and radiating cracks of the Tear-figures.

In the previous articles<sup>1</sup>, the author has discussed only the shapes of tear-figures, and a problem concerning the inclination of the walls and cracks of a tear-figure pit has remained untouched because of the difficulty of measuring it. Measuring the inclination with the reflecting goniometre is actually impossible, owing to the extreme smallness of the wall. When stronger percussion or pressure is applied on a crystal with the purpose of making a figure large enough for observation, it becomes irregular or sometimes breaks up. An inclined wall always shows a broad dark band under the microscope, because the light rays striking against it are reflected outside the objective with either vertical illumination or transmitted light. Fig. 41 *a* illustrates the manner in which the rays are reflected by the

1) Mikio Kuhara, "Tear-figures on Certain Minerals. I-III." *Loc. cit.*

inclined wall when an opaque mineral is observed with vertical illumination and Fig. 41*b* illustrates such reflection in the case of a transparent mineral with transmitted light.

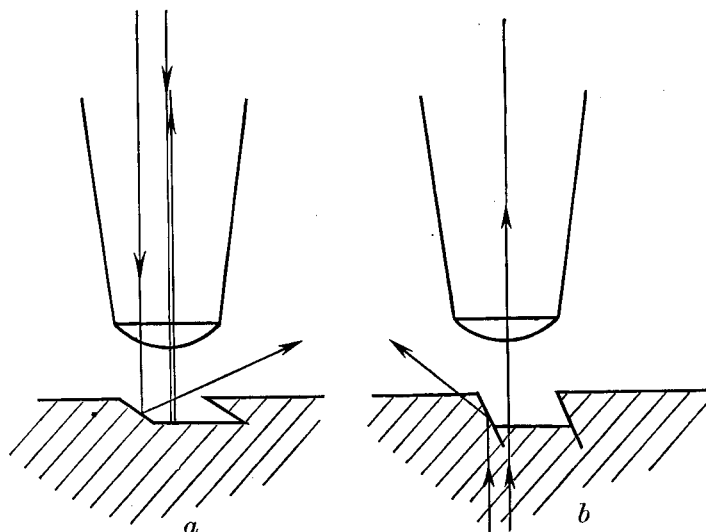

Fig. 41.

One side of the broad dark band is always sharp and the other irregular. The sharp side is the intersection of the inclined wall and its mother face, and the other its lower termination (Fig. 42).

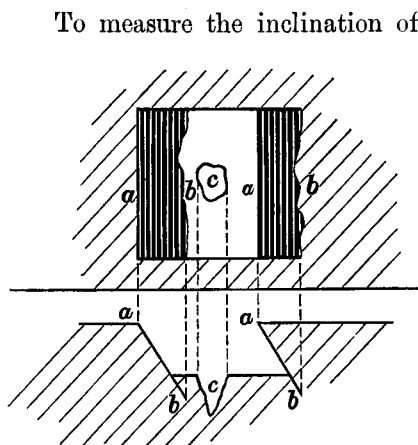

Fig. 42.

*a b*.....inclined wall.  
*c*.....pit of a needle-point.

To measure the inclination of the wall, at first the face to be examined is placed exactly perpendicular to the axis of the microscope tube, next the crystal is rotated to such a position that the dark band becomes a sharp straight line, then the angle is read. This is the complement of the angle between the mother face and a crystal face to which the wall of the tear-figure is parallel. In Table I, the figures within brackets indicates the crystal face to which a wall or a crack is parallel, the others without brackets only their



TABLE I. The examined crystal faces and the tear-figures on them.

System	Mineral	faces	Direction of walls, and cracks of the tear-figures.																		
Cubic	Galena	100			(100)																
		111			(100)																
	Sphalerite	111										111									
	Pyrite	100			(100)							111									
	Alum	100		(110)	(100)																
		111									(111)										
Tetr.	Wulfenite	001		(110)	(100)																
Rhomb.	Stibnite	001	(010)	(110)	(100)																
		111	010	110																	
		010											(011)								
	Enargite	100		(110)	(100) <sup>1</sup>	(001)							(011)								
		001		(110)	(100)																
	Barite	001	(010)	(110)	(100)																
		110		(110)		(001)															
	Aragonite	100	(010)								(101)?			032							
		010			(100)	(001)							(h01)	or β, γ							
		001		(110)																	
110		(010)?											021	(h51) <sup>2</sup> & two in-							
011			(110)											determinable							
cracks																					
Hexag.	Calcite	0001											(10 $\bar{1}$ 0)								
	R							(0001)					(R?)								
Monoc.	Vivante	010			(100)								(101)	( $\bar{1}$ 01)							
Gypsum		100	(010)			(100)							(101)								
	111	(010)			(100)																
	010				(100)	(001)							( $\bar{1}$ 01)	( $\bar{2}$ 01)							
	001	(010)																			
	010																				
Borax	100	010			001	111													221		
	111	(010) <sup>3</sup>	110	100															041		
	010			(100)	(001)						(101)										
Tric.	Copper-sulphate	001		110	100															041	
		100		$\alpha$	110																
		111	$\epsilon$	110	$\alpha$	$\beta$						$\beta$	$\gamma$							$\delta$	
		010		110	100	$\bar{1}\bar{1}0$							$\gamma$	$\delta$							$\epsilon$
		110										$\alpha$	$\beta$	$\gamma$	$\delta$						

1) The bottom of the tear-figure.

2) The obtuse angle between the wall and its mother crystal face is 20°-65°.

3) " " " " " " " " " " 55°-65°.

horizontal directions, the estimation of their angles not having succeeded owing to various obstacles.

A wall or a crack of the tear-figure which is  $90^\circ$  to its mother face always shows a sharp line, with the following exceptions:

- a) when the face to be examined is not cut strictly parallel to the natural face.
- b) when the face to be examined is not placed strictly perpendicular to the axis of the microscopic tube.
- c) when numerous parallel cracks are produced closely together along a wall of the tear-figure.

### Application of Tear-figures.

As the author has described, in his articles on each mineral, the application of tear-figures to practical mineralogy, he desires here to summarize it.

As a tear-figure has its own shape peculiar to a crystal face, it is known by that to what face its mother face belongs.

A tear-figure sometimes possesses a wall or a crack parallel to a face which presents itself only in a more complicated form than its mother crystal; example, the six-sided figure on the basal section of  $\{R\}$  of calcite.

Sometimes a wall of a tear-figure indicates a face which is not ordinarily found on its mother crystal. In this case, it suggests the presence of such a new face; example,  $(\bar{2}10)$  of gypsum, and the faces parallel to the tentacles and tails of the butterfly-shaped figure of aragonite.

Two different crystals with faces of similar shape, same direction of cleavage, similar hardness and colour, etc., are sometimes distinguished by tear-figures; example, the rhombic figure on  $\{001\}$  of aragonite and the six-sided figure on  $\{0001\}$  of calcite; the rhombic figure on  $\{R\}$  of calcite and the six-rayed figure on  $\{001\}$  of barite.

### Summary and conclusions.

When a stripping action by any mode of formation is given upon a crystal face (natural and artificial) or cleavage face of certain crystals, tear-figures are produced. The common mode of formation is that a light percussion or pressure of a needle-point is applied vertically to a well-polished face. The most important factors producing a beautiful figure are the softness and the brittleness of the crystal, smoothness of the polished face and development of cleavages. When a needle is applied obliquely to the face, the tear-figure has a defective form, especially in the direction of the needle-point by the lateral pressure of it. See Fig. 1, PL. IX, "Tear-figures, etc., II.," the Newton rings are seen on the defective side of the rhombic figure of calcite. Tear-figures usually have a polygonal body and radiating cracks, but the latter can not be seen on an opaque mineral though their presence is possible.

The walls bounding the polygonal body and the cracks are almost always parallel to certain crystal faces which commonly occur. The inclination of a wall and a crack of tear-figures sometimes can be estimated and sometimes can not, but that of the bottom of a pit rarely can because usually it is broken by the percussion of the needle-point.

The symmetry of a tear-figure is quite concordant with that of the mother crystal, that is to say, the number of the plane or axis of symmetry of the former is equal to that of the symmetry plane of the latter which perpendicularly cuts the face on which the tear-figure stands and they are always parallel.

The tear-figure has a close relation to the direction of the molecular cohesion of a crystal, that is to say, the direction of a wall or crack of a tear-figure is perpendicular to a direction of weak cohesion. The phenomenon of cleavage depends upon differences in cohesive power in different directions in a crystal. A distinct cleavage plane is always perpendicular to the direction of weaker cohesion, and the gliding plane to the direction of stronger cohesion. Thus it is certain that a cleavage plane must be parallel

to a certain wall or crack of a tear-figure but the gliding plane never parallel to the latter unless it coincides with the cleavage plane. In support of this view is the following table:

TABLE II. Relation of tear-figures to cleavage and gliding planes.

Minerals	Cleavages (Dana) <sup>1</sup>	Gliding planes <sup>2</sup> (Vernadsky)	Walls and cracks of tear-figures
Stibnite	010, 100, 110, 001, (gliding)	041, 051, and other brachydomes also macrodomes.	(010), (110), 001, 111, (100), (011)
Galena	100, 111	110	(100)
Sphalerite	111		111
Pyrite	None		111, (100)
Vivianite	010,* 100	10 $\bar{3}$ and hemiortho- domes	(100), (101), ( $\bar{1}$ 01)
Enargite	110, 100, 010,* 001		(110), (100), (001), (011)
Calcite	R, 01 $\bar{1}$ 2 (parting), 11 $\bar{2}$ 0 (parting)	01 $\bar{1}$ 2	(R), (0001), (10 $\bar{1}$ 0)
Gypsum	010, 100, $\bar{1}$ 01, 111,† 509,† 103†	101, $\bar{1}$ 03	(010), (100), ( $\bar{1}$ 01), (001), ( $\bar{2}$ 01).
Barite	001, 110, 010	011, 110, 601?	(001), (110), (100), (010)
Aragonite	110, 011	110 and brachydomes	(100), (010), 021, (h51), 032 (110), (001), (h01 ( $\beta$ , $\gamma$ )), (101) and two indeterminate cracks
Alum			(100), (111), (110)
Borax	100, 110, 010		(100), 110, 010, 041, 111, (001), <u>221</u> (101)
Wulfenite	111, 001, 113†		(110), (100)
Copper-sulphate	1 $\bar{1}$ 0, 110, 111		1 $\bar{1}$ 0, 110, 111, <u>010</u> , and 12 other cracks

In the table almost all the cleavage directions coincide with those of certain walls or cracks of the tear-figures except four, while no gliding-plane has its equivalent among the latter.

The walls or cracks of the tear-figures underlined have no equivalent among the cleavage planes.

1) Dana, System of Mineralogy, The sixth edition.

2) W. Vernadsky, "Gliding phenomena of crystalline substances." (Russian), Scientific papers of the Imperial University of Moscow, Sec. of natural history, part 13.

†) Have no equivalent among the walls and cracks of tear-figures.

\*) The presence of their equivalent in the tear-figure is probable but an experiment on them has not been undertaken.

The crystals selected for examination are of soft ones ( $H=1.-3.$ ) for easiness of producing tear-figures. If the crystal is harder, the point of an ordinary sewing-needle cannot make a pit on it, so a needle of a harder material such as high-speed steel must be used. A friend of the author's succeeded in making a tear-figure on a certain alloy-crystal with a needle of such material.

[End]

---



Fig. 1. Tear-figures on  $\{001\}$  of wulfenite.  
 a, b and d.....a common type of the figures.  
 The sides are slightly curved giving the figures a rounded appearance.  
 c and e.....a crossed figure, an imperfect one.  
 Transmitted light. Mag. 60 diam.

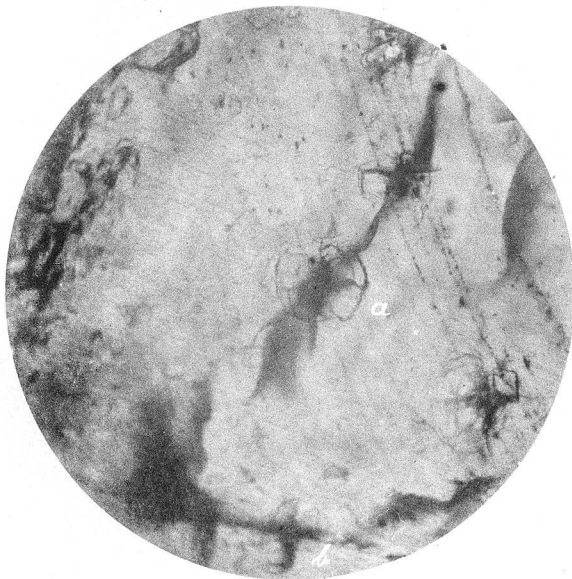

Fig. 2. Tear-figures on the same face of the same crystal.  
 a.....a perfect figure consisting of a square, crossed  
 and diagonal cracks.  
 b.....an imperfect figure consisting of crossed  
 cracks and half of the square.  
 Transmitted light. Mag. 60 diam.

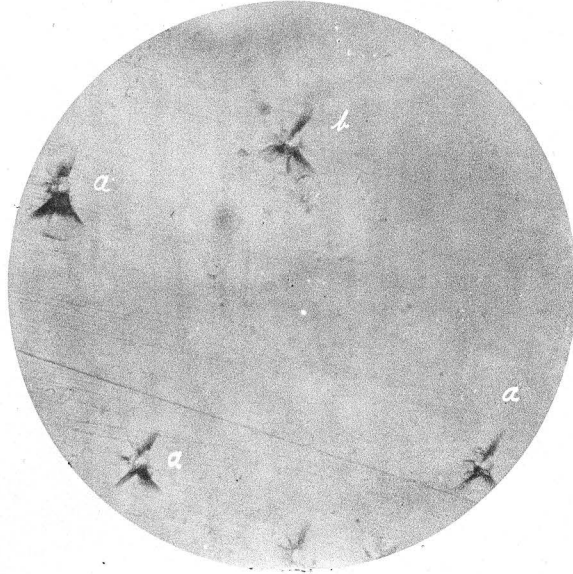

Fig. 1. Tear-figures on  $(\bar{1}\bar{1}0)$  of copper-sulphate crystal.  
 a.....a common type, composed of four cracks.  
 b.....a somewhat complicated type with a vertical crack.  
 Transmitted light. Mag. 60 diam.

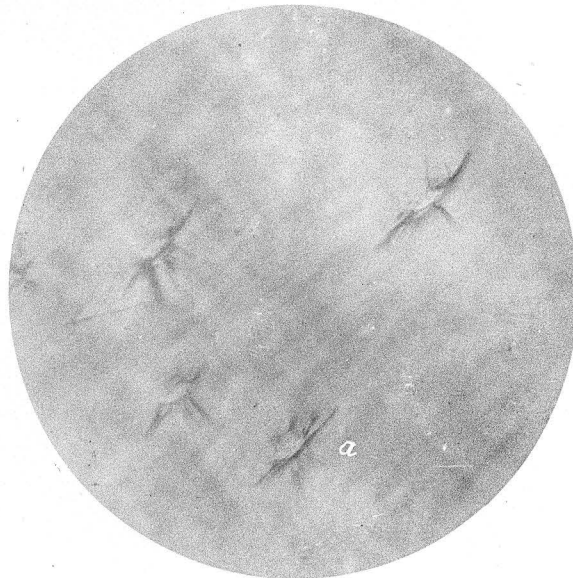

Fig. 2. Tear-figures on  $(100)$  of copper-sulphate crystal.  
 a.....a perfect form but the central polygonal figure is indistinct.  
 Other figures are imperfect.  
 Transmitted light. Mag. 100 diam.

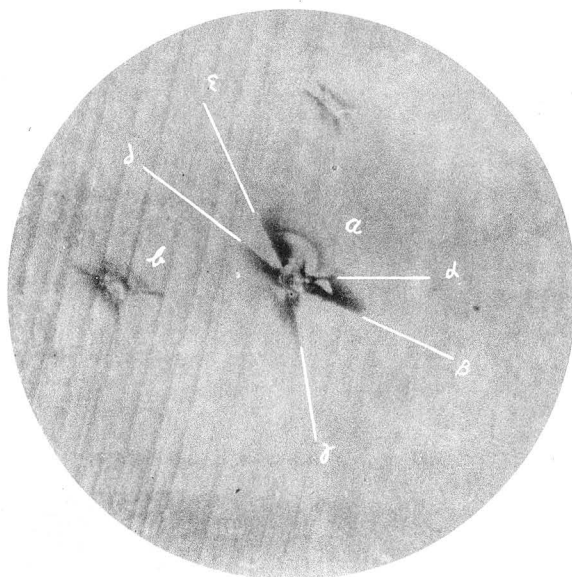

Fig. 1. Tear-figures on (111) of copper-sulphate crystal.  
 a.....a perfect form with cracks parallel to  $\{100\}$ ,  $\{\bar{1}\bar{1}0\}$  and  $\{010\}$ .  
 b.....an imperfect one with a rhombic body, whose sides are parallel to  $\{110\}$  and  $\{\bar{1}\bar{1}0\}$  and four rays, two of which are parallel to  $\{100\}$  and  $\{\bar{1}\bar{1}0\}$ .  
 The parallel streaks through the photomicrograph are polishing scratches. Transmitted light. Mag. 115 diam.



Fig. 2. Tear-figures on the same face as Fig. 1. Various shapes of imperfect figures. The parallel streaks are polishing scratches.  
 Transmitted light. Mag. 60 diam.



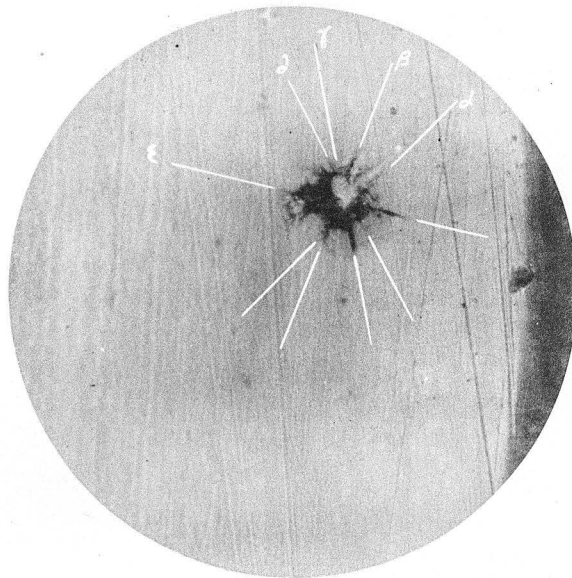

Fig. 1. Tear-figures on (010) of copper-sulphate crystal.  
 Perfect many-rayed figure,  $\alpha$  being only one crack  
 parallel to a crystal face, (111).  
 Black part on the right is an edge between (010) and ( $\bar{1}10$ ).  
 The parallel streaks are polishing scratches.  
 Transmitted light. Mag. 200 diam.

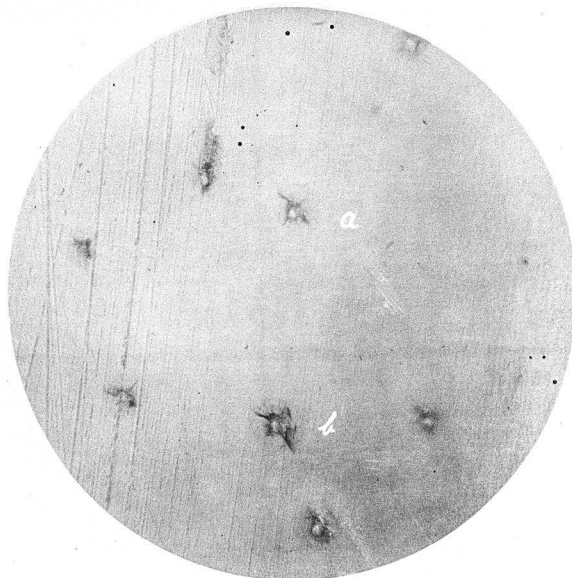

Fig. 2. The same as Fig. 1.  
 Imperfect forms.  
 a.....four-rayed figure consisting of the two cracks  $\alpha$  and  $\delta$ .  
 b.....three-rayed figure consisting of three cracks  $\alpha$ ,  $\delta$  and  $\epsilon$ .  
 The parallel streaks are polishing scratches.  
 Transmitted light. Mag. 60 diam.