



TITLE:

Tear-Figures on Certain Minerals I

AUTHOR(S):

Kuhara, Mikio

CITATION:

Kuhara, Mikio. Tear-Figures on Certain Minerals I. Memoirs of the College of Engineering, Kyoto Imperial University 1916, 1(8): 267-274

ISSUE DATE:

1916-10-25

URL:

<http://hdl.handle.net/2433/280020>

RIGHT:

Tear-Figures on Certain Minerals. I.

By

Mikio Kuhara.

When a light stroke or pressure is applied with a hard point vertically to a crystal face or a cleavage plane of certain minerals, a pit may be produced forming a peculiar figure, the shape of which well accords with the symmetry of the crystal. A same figure is sometimes produced by stripping off the cleavage planes. Such a figure must be formed by a tear-off action which naturally takes place by the above methods, and hence it is denominated a "TEAR-FIGURE" by the author.

The molecules of crystals have different cohesive power in different directions. Because of this characteristic, a crystal takes its own peculiar form, and possesses a marked tendency to split along certain directions. The planes along which such splitting occurs are known as cleavage. Thus a tear-figure must have close relation to this property and hence accords with the outer form and symmetry of its host crystal.

The tear-figures on the common faces (natural and artificial) and on the cleavage faces of certain minerals have been studied by the author.

For convenience in studying the relations between the figures and the symmetry of the crystals, the specimens were taken from those which have perfect crystal forms.

If a mineral is soft, brittle and has perfect cleavage, beautiful figures are produced easily by pressing a pin's point lightly against a well polished face or by strongly stripping off cleavage planes.

If a mineral is harder, less brittle and has imperfect cleavage, after pits have been made with a pin's point, it should be polished lightly with fine emery paper and then with rouge on broad-cloth to bring out the figures.

If still harder and a pin's point does not scratch the mineral, a corner of diamond may be used, and then polished, if necessary. Tear-figures may be produced upon certain minerals merely by polishing or by lightly tapping on a hard flat surface without making any pit with a hard point.

The figures thus produced were observed under the reflecting microscope with vertical illumination.

Earlier investigators of similar subjects are Cesàro,¹ Vernadsky,² Valentin,³ Samojloff,⁴ and Mügge.⁵

Samojloff⁶ has observed isosceles-triangular figures on the artificial section parallel to the base of a rhombohedron of calcite. These triangular figures were oriented in three directions making an angle of 120° one another. Each triangle had its base parallel to the edges between the base and the rhombohedral face of calcite and its apex on the opposite side of the edge. In short, the each direction of the three groups of triangles was parallel to one of the three symmetrical planes of the calcite. The apical angle of the triangle was 30°. He considers these figures to have been produced during polishing. He has not observed any figure on the face of the rhombohedron. He also has made similar figures by stripping a minute slice off a basal pinacoid of calcite with the point of a needle. Samojloff named these figures "ABREISSUNGSFIGÜREN"⁷ on calcite.

Cesàro⁸ discovered the same figure on the same section, (001), of calcite by rubbing it with charcoal.

1) Cesàro, *Annal. Soc. Géolog. Belge.* 1890, XVII, 116 and *Bull. Soc. Minér. d. I France* 1890, XIII, pp. 193. *Ref. Zeit. für Cryst. und Miner.* XXI, pp. 303.

2) W. Vernadsky, *Gleitungserscheinungen* (russ), Moskau 1898, pp. 147 and 172. *Extract Zeit. für Cryst. und Miner.* XXXI, pp. 519.

3) J. Valentin, *Zeit. für Cryst. und Miner.* 1889, XV, pp. 576.

4) J. Samojloff, *Verhandl. d. russ. Miner. Geselsch.* 1900, XXXVIII, pp. 343 und *Bull. d. Natur. de Moscou* 1902, XVI, pp. 233. *Ref. Zeit. für Cryst. und Miner.* XXXVI, pp. 172 und XXXIX, pp. 19, 1904.

5) O. Mügge, *Centralblatt für Miner. etc.* IV, pp. 405, 1904.

6) J. Samojloff, *Zeit. für Cryst. und Miner.* XXXIX, pp. 19, 1904.

7) The author employs the term "Tear-figure" in the same sense as "Abreissungsfigur" of Samojloff.

8) *Loc. cit.*

Samojloff⁹ and Valentin¹⁰ have observed the natural "Abreissungsfiguren" on the basal pinacoid of barite. They were isosceles triangles which accorded with but one plane of symmetry.

The following minerals have been examined by the author, of which the last three do not produce a figure sufficiently distinct to show characteristic form.

Stibnite, galena, sphalerite, pyrite, vivianite, enargite,
molybdenite, chalcopyrite, and hematite.

The author desires to thank Baron Fujita for his kind favour, and Professor D. Saito, and Assistant Professor T. Hiki of the Imperial University of Kyoto for their kind advice and valuable instructions.

Lastly he is also obliged to Professor K. Jimbo of the Imperial University of Tokyo for useful hints.

Stibnite.

The specimen was a long prismatic crystal developing the faces $\{111\}$, $\{110\}$ and $\{010\}$. The plane angle made by the edge between (111) and (010) and the edge between $(\bar{1}\bar{1}\bar{1})$ and (010) was about 90° (Fig. 1, a). H-2; cleavage perfect pinacoidal, yielding blade-like strips which are striated perpendicularly to the long direction; very brittle; crystal system rhombic.

A cleavage surface (010) was carefully examined under the micro-

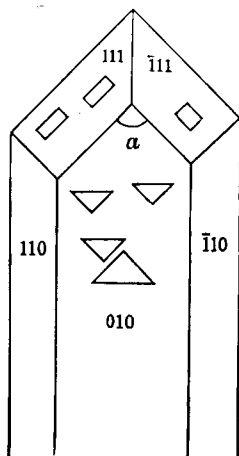

Fig. 1.

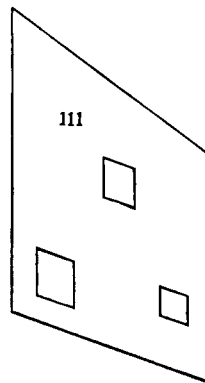

Fig. 2.

9) Loc. cit.

10) Loc. cit.

scope. Then, on the clear and scratchless portion, a pin's point was pressed very lightly and several pits were made. Upright and inverted isosceles-triangular figures, arranging their bases parallel to that of the stibnite, were discovered under the microscope, (Fig. 1; Fig. 1. Pl. I).

These figures have been produced also by stripping off cleavages (Fig. 2, Pl. I; Fig. 1, Pl. II). These triangles show angles of approximately 90° on their apices. Thus it is clear that the two equal sides are parallel to $\{111\}$, and the base is parallel to a symmetrical plane.

On the face (111) , the tear-figure has a rhombic form bounded by sides parallel to the crystal face (110) and (010) (Fig. 1 and 2).

On the basal section, three kinds of figures have been produced, namely *three-, four- and six-sided*. Of these figures, the last form is considered to be of perfect one being in harmony with the base of the stibnite. Its longer axis is parallel to the cleavage striations, or face (010) (Fig. 3. a; Fig. 2, Pl. II). In this case the two symmetrical axes of the figure are parallel to the planes of symmetry of the crystal.

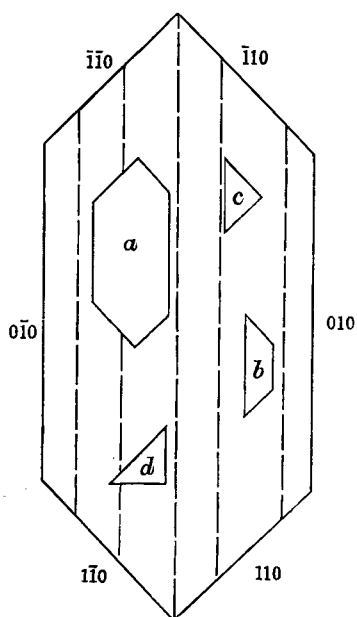

Fig. 3.

The second figure is trapezoidal, and seems to be a half form of the six-sided, with sides parallel to faces (110) , $(\bar{1}\bar{1}0)$, $(0\bar{1}0)$ and (010) (Fig. 3, b).

The first figure is a right-angled triangle arranging its base parallel to or 45° from a cleavage striation (Fig. 3, c and d; Fig. 1, Pl. III); the former is considered to be the second (four-sided) form wanting one side, and has sides parallel to faces (110) , $(\bar{1}\bar{1}0)$ and (010) ; and the latter also is a reduced form having its sides parallel to the crystal faces $(\bar{1}\bar{1}0)$, (010) and (100) .

Galena.

The examined specimen was a cube.

H-3; cleavage perfect cubic. A pressure with a pin's point on the polished cubic face has produced square figures with sides parallel to the cubic faces (Fig. 4; Fig. 2, Pl. III). On any section except cubic one, various triangular shapes have appeared according to the direction of cutting; for example, on the section rightly replacing an angle of a cube, an equilateral triangle has been produced, and on the random section, unequilateral triangle, (Fig. 5; Fig. 1, Pl. IV).

Thus when an aggregate of galena are cut and polished, various shapes of triangles are found on a same section. (Fig. 2, Pl. IV).

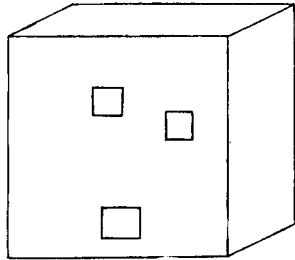

Fig. 4.

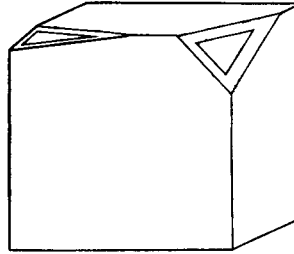

Fig. 5.

Sphalerite.

The specimen was crystallized in octahedron. H-4; cleavage perfect dodecahedral; brittle. An octahedral face was polished, and pits were made with a pin's point, then polished again on broad-cloth.

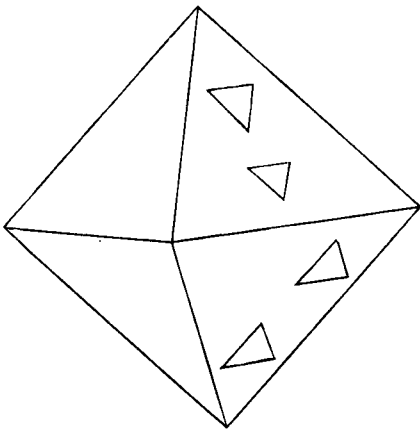

Fig. 6.

Inverted equilateral-triangular figures, each side parallel to the face of the octahedron, have been formed (Fig. 6; Fig. 1 and 2, Pl. V).

Pyrite.

The specimen was a cubic crystal striated. H-6; cleavage, none apparent brittle; cubic system. A cubic face was polished.

A pin's point does not scratch it. The photographed figures have been produced by polishing with fine emery paper and rouge. Two kinds of figures have been observed on the same cubic face, the one being a right-angled triangle with base 45° from the edges of the cube (Fig. 7; Fig. 2, a, Pl. VI) and the other a square with sides parallel to the cubic faces (Fig. 7; Fig. 2, b, Pl. VI).

The former (triangle) seems to be an imperfect form of the latter (square).

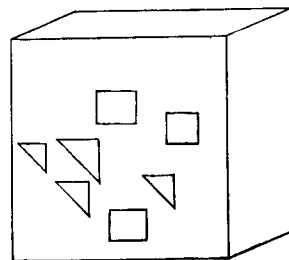

Fig. 7.

Vivianite.

The specimen was a cleavage piece. H-1,5 to 2; cleavage perfect pinacoidal; brittle; monoclinic system. A pressure on the cleavage face (010) with a pin's point very easily give rise to isosceles (right-angular?) triangles. The relation between the symmetry of the crystal and the figures was not clearly determined owing to the imperfect termination of the crystal (Fig. 8; Fig. 1, Pl. VII).

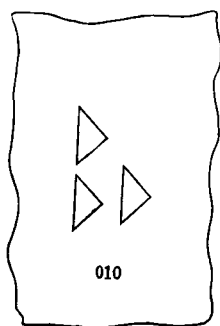

Fig. 8.

Enargite.

The specimen was a prismatic crystal. H-3; cleavage perfect prismatic; brittle; rhombic system. A light stroke on the face (100) with a pin's point and polishing have produced three kinds of tear-figures, *six-*, *four-* and *three-sided*. The six-sided is bounded by sides parallel to (001), (011), (110), (01 $\bar{1}$), (00 $\bar{1}$), and (1 $\bar{1}$ 0) (Fig. 9, a; Fig. 2, Pl. VII). This figure is considered to be the right-half form of an eight-sided symmetrical figure, though the

eight-sided figure has not been observed in my experiment. The four-sided figure which has sides parallel to (001) , (110) , $(00\bar{1})$, and $(1\bar{1}0)$ is an imperfect form of the former. Most of the figures produced in the experiment belong to this class, and the other two kinds are few in number.

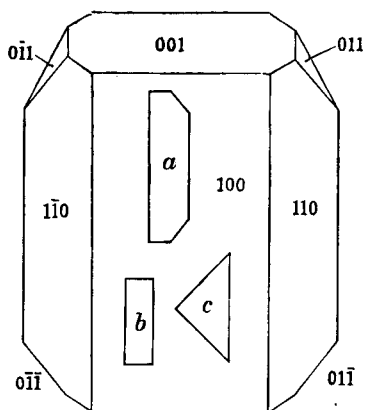

Fig. 9.

The triangular figure, having its base in a vertical direction and sides parallel to $(0\bar{1}1)$ and $(0\bar{1}\bar{1})$, is extremely reduced in form (Fig. 9, c; Fig. 1, Pl. VIII).

On the basal section, two types of figures have been produced by polishing, the one being a trapezoid with sides parallel to (100) , $(1\bar{1}0)$, $(\bar{1}00)$, and (110) (Fig. 10, a; Fig. 2, a, Pl. VIII) and the other an isosceles triangle with sides parallel to (110) , $(1\bar{1}0)$ and $(\bar{1}00)$, and

with angle of about 95° at the apex (Fig. 10, b; Fig. 2, b, Pl. VIII).

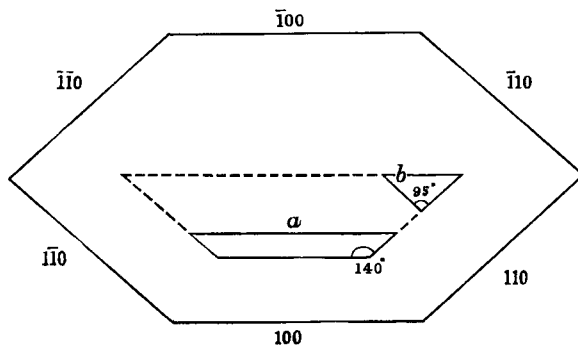

Fig. 10.

From the results of the foregoing investigation, it seems reasonable to conclude that:

When a stripping action is given upon certain minerals, tear-figures are produced.

The factors which produce the beautiful tear-figures are brittleness and softness of the crystals, and perfection of the cleavage.

Thus, for example, stibnite which has these three factors perfectly, produces the most beautiful figures.

Of these three factors, the most important is the brittleness of the crystals. Thus, for example, molybdenite, though easily cleavable and extremely soft, does not produce a figure owing to its great flexibility.

As far as observed, figures usually are bounded by sides parallel to the crystal faces that bound the face on which the figures stand. Consequently, a perfect figure has the same form as its host crystal face, and accords with the symmetry of the crystal.

Sometimes a figure wants one or more sides, is reduced into a simpler form and shows a result like *MEROHEDRISM* of crystals.

If it is true that a perfect tear-figure has the same form as that of the crystal face on which the figure stands, the appearance of such a perfect figure will hint us at knowing not only the shape and kind of its associated face, but also the symmetrical condition that the host crystal carries.

It is believed that much remains to be learned regarding tear-figures.

A second paper is under preparation, in which the character of tear-figures on other minerals than those studied in this paper will be presented.

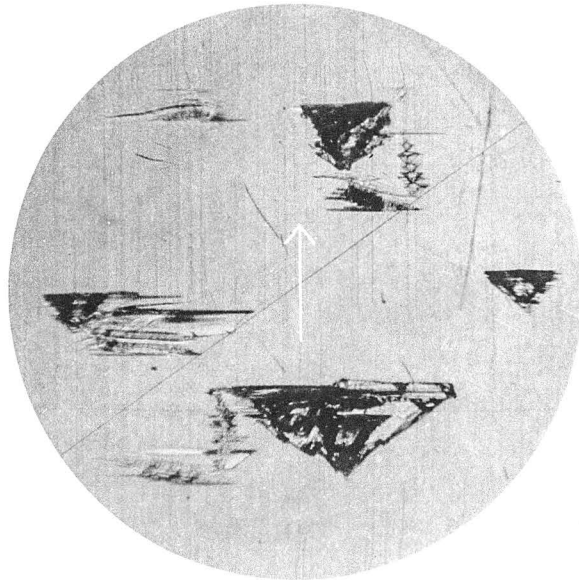

Fig. 1. Tear-figures on a cleavage face of stibnite.
Vertical illumination.
Magnification 75 diá.
Arrow shows the direction of c-axis.

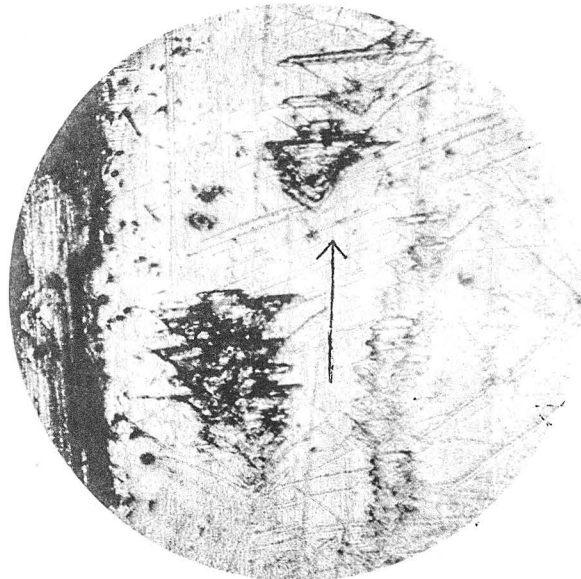

Fig. 2. Tear-figures produced by stripping off stibnite along the cleavage planes. Vert. illum.
Mag. 75 dia.
Arrow shows the direction of c-axis.

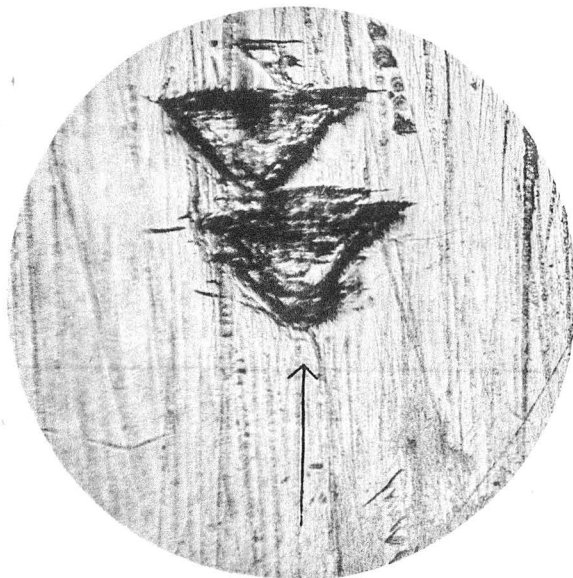

Fig. 1. Same as fig. 2, Pl. I.



Fig. 2. Tear-figures on a basal section of stibnite. Vert. illum. Mag. 60 dia.
The two straight lines intersecting at the apex of (a) are parallel to $\{110\}$ and form an angle of about 90° . Cleavage direction from North to South.

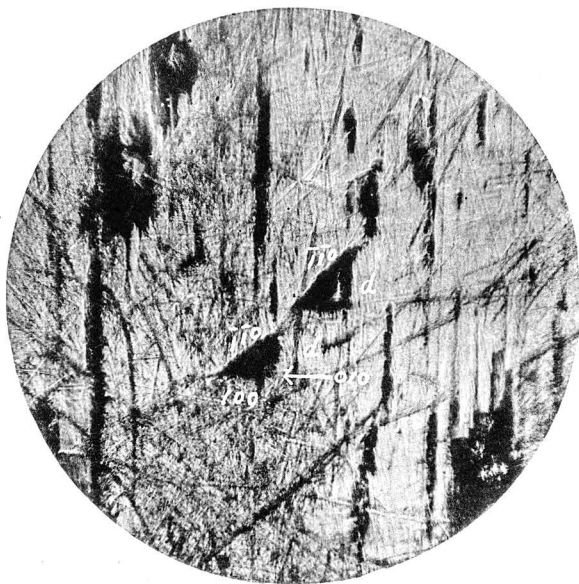

Fig. 1. Same as Fig. 2, Pl. II. but imperfect forms of the former, (d).
Cleavage direction from North to South.

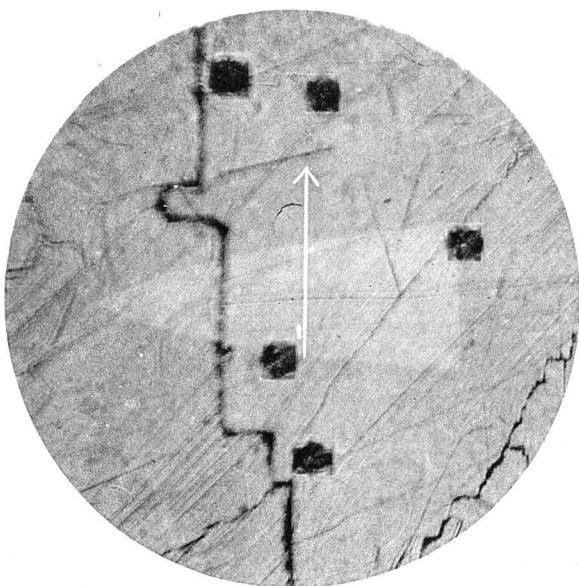

Fig. 2. Tear-figures on a cubic face of galena. Vert. illum.
Mag. 115 dia.
Arrow shows the direction of a cubic axis.

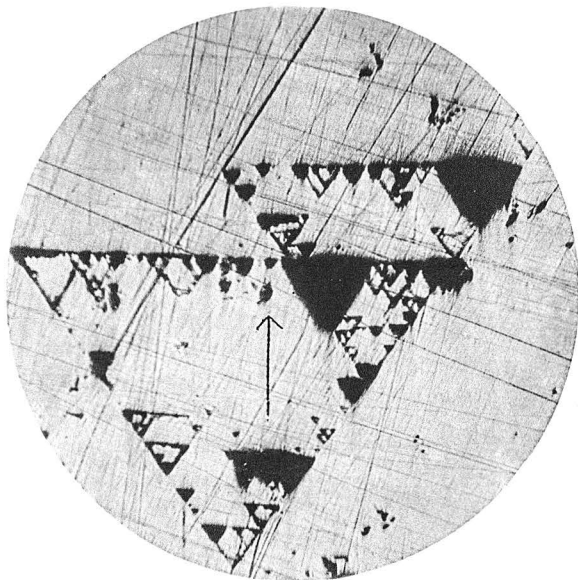

Fig. 1. Tear-figures on an octahedral section of galena.
Vert. illum.
Mag. 60 dia.
Arrow shows the direction of a cubic axis.

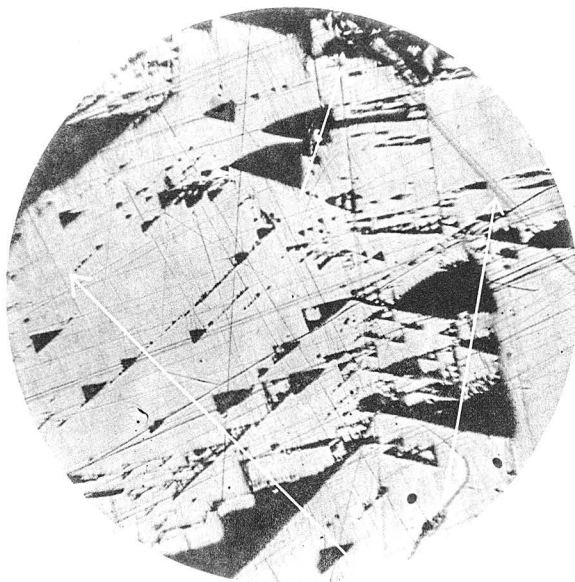

Fig. 2. Tear-figures on a section of an aggregate of galena.
Vert. illum. Mag. 60 dia.
Unparallel directions of triangles show the different
individual crystals.
Arrows show axes of three individual crystals.



Fig. 1. Tear-figures on an octahedral face of sphalerite.
Vert. illum. Mag. 60 dia.
Arrow shows the direction of a cubic axis.

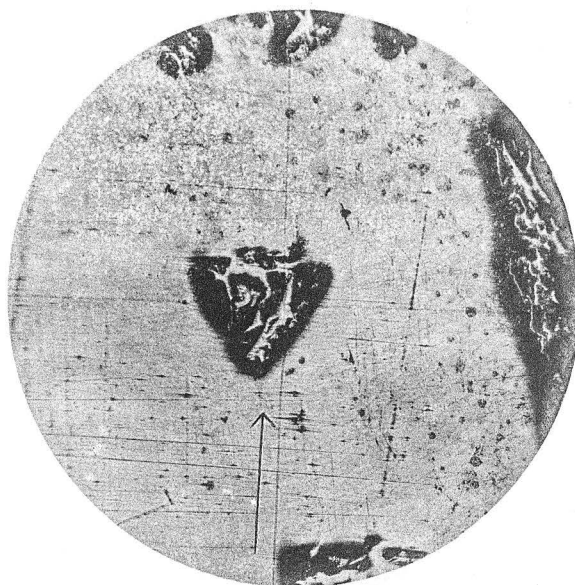

Fig. 2. Tear-figures. Same as fig. 1. Pl. V,
Arrow shows the direction of a cubic axis.



Fig. 1. Tear-figures on a cubic face of pyrite produced by merely polishing. Vert. illum.
Mag. 75 dia.
Arrow shows the direction of a cubic axis.

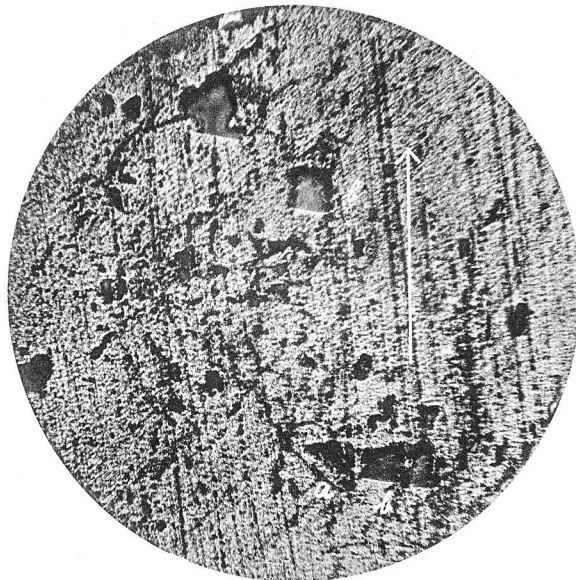

Fig. 2. Tear-figures on a cubic face of pyrite. Triangular (a) and square (b) figures are shown. Vert. illum.
Mag. 75 dia.
Arrow shows the direction of a cubic axis.

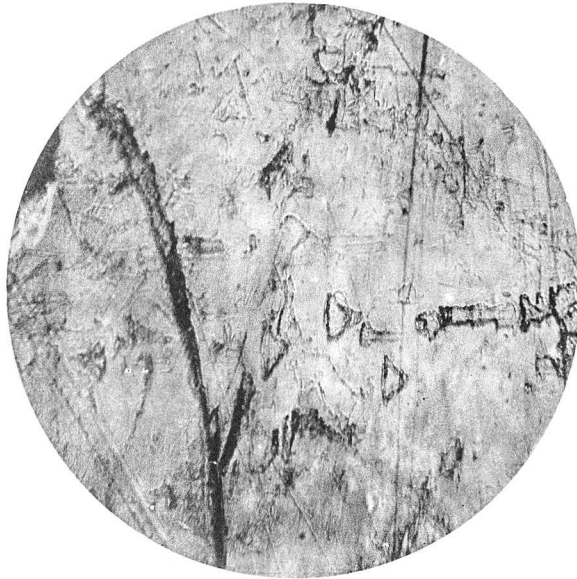

Fig. 1. Tear-figures on a cleavage face of vivianite.
Vert. illum. Mag. 60 dia.
The directions of axes are unknown owing to
the imperfect terminations of the crystal.

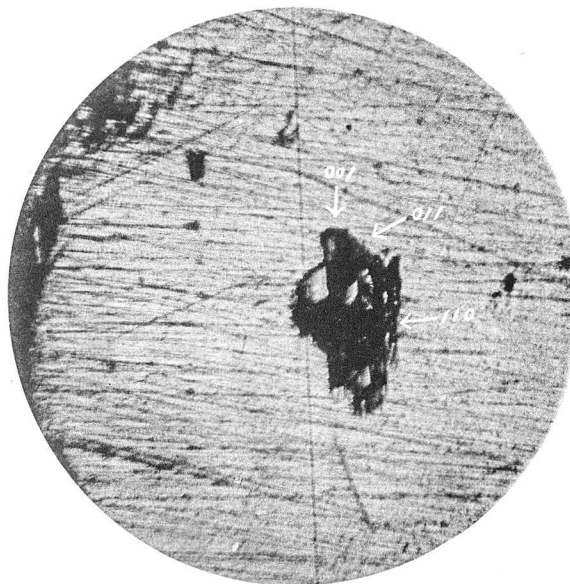

Fig. 2. Tear-figure on the (100) face of enargite. The six-sided
type bounded by sides parallel to $(00\bar{1})$, $(01\bar{1})$, $(1\bar{1}0)$, $(0\bar{1}\bar{1})$
 $(00\bar{1})$, and $(1\bar{1}0)$. The rounded image on the left hand is the
pit of a pin's point. The direction of the vertical axis from
North to south. Vert. illum. Mag. 60 dia.

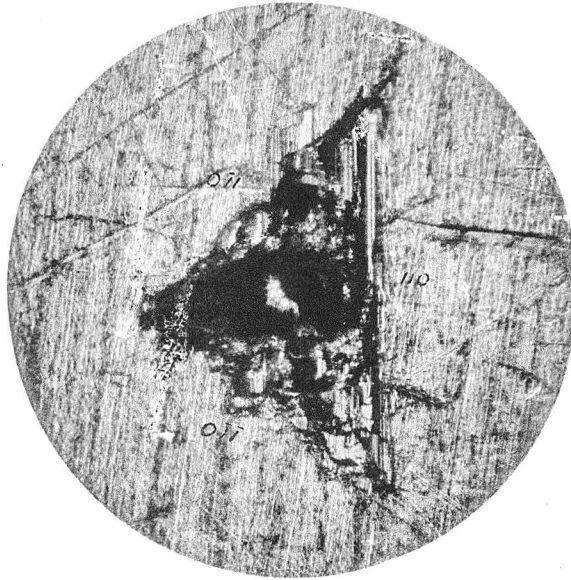

Fig. 1. Tear-figures on the face (100) of enargite. The Triangular type reduced from the four-sided type. As a whole, the figure is composed of parallel aggregate of four-sided prismatic figures. The direction of the vertical axis from North to South. Vert. illum. Mag. 130 dia.

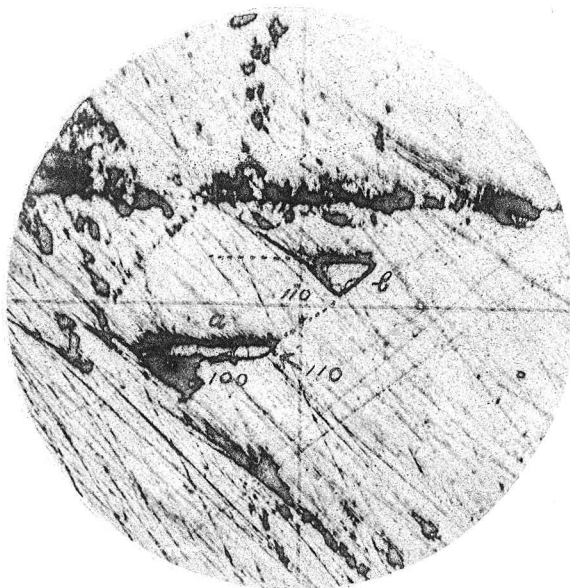

Fig. 2. Tear-figures on a basal section of enargite. Trapezoidal (a) and triangular (b) figures are shown. AB.....the direction of the brachy-axis. CD.....the direction of the macro-axis. Vert. illum. Mag. 50 dia.