

Representation of Urban Recharge Processes in the Distributed Recharge Model (ZOODRM) of the Glasgow urban area, Scotland

Majdi M Mansour¹, Andrew G Hughes², Brigid O'Dochartaigh³ and Malcolm T Graham³

¹British Geological Survey, *majm@bgs.ac.uk*, Wallingford, UK

²British Geological Survey, *aghug@bgs.ac.uk*, Keyworth, UK

³British Geological Survey, *beod@bgs.ac.uk*, *mtg@bgs.ac.uk*, Edinburgh, UK

ABSTRACT

Current interest in groundwater in the Glasgow area is being driven by ongoing urban regeneration and development, and is largely focussed on the role of shallow groundwater and its interaction with surface water. There is a need to improve the overall understanding of the hydrogeology of the whole of the Glasgow city area. The object-oriented recharge code ZOODRM has been applied to construct a water balance for the full Clyde Basin catchment. Because of the intense urbanisation of the study area ZOODRM has been modified and a new urban leakage mechanism has been added to simulate urban recharge processes. Detailed land-use mapping has been used to calculate the percentages of the major urban area features (buildings, gardens, and roads) within each model node. The culverted rivers in the Glasgow city area have been included in the model using the numerical river object. The model has been calibrated by matching the simulated and observed river flows. The newly developed urban leakage mechanism allows a more realistic representation of the urban recharge and run-off processes.

INTRODUCTION

Large parts of the Glasgow urban area are currently undergoing regeneration and development work. Interest in groundwater in these areas is largely focussed on the role of shallow groundwater and its interaction with surface water. To effectively understand and deal with development and planning issues, it is necessary to improve the overall understanding of the hydrogeology of the development areas. Management of urban surface water and groundwater has been given increased attention in recent years, for example the construction of 3D geological models for selected urban areas in the UK (Lelliott et al., 2006). To better understand the hydrogeology of the Glasgow area, groundwater modelling is undertaken using the ZOOM suite of object-oriented (OO) numerical groundwater models (Spink et al., 2006). OO techniques are widely used in commercial computer software. The suite of OO models used for this study includes a groundwater flow model, ZOOMQ3D (Jackson and Spink, 2004) and a distributed recharge model, ZOODRM (Hughes et al. in press).

The Glasgow city area is highly urbanised. Surface run-off is enhanced under these conditions and there is additional indirect recharge generated from leakage from pressurised water mains and damaged storm and sewage sewers. There is also significant water transfer from impermeable features such as roofs to open areas like gardens. Under these circumstances the conventional recharge calculation methods, for example the soil moisture deficit (SMD) method, are not applicable and alternative methods must be developed. ZOODRM is updated to include a recharge calculation method that better represent the key recharge mechanisms in urban areas. This method is presented in this paper.

DESCRIPTION OF THE RECHARGE MODEL ZOODRM

ZOODRM allows local grid refinement to increase the resolution of the recharge calculations over discrete areas. Recharge calculations over a grid node can be undertaken using one of three recharge calculation methods. These are the conventional Soil Moisture Deficit (SMD) method (Penman, 1948 and Grindley, 1967), the Environment Agency / FAO method (Hulme et al., 2002), and a specific method for recharge calculation in semi-arid areas (Hughes et al., in press). A daily time step is used for the recharge calculation. Each grid node is linked to a rain gauge by means of Thiessen polygons to obtain the daily rainfall and potential evaporation (PE) values. These values are varied across the model nodes and located within one polygon by multiplying them by the ratio of the long term average (LTA) rainfall and

LTA PE values calculated at the weather station and LTA rainfall and PE values at the grid nodes. LTA rainfall and potential evaporation (PE) values are estimated at the grid nodes by contouring the LTA rainfall and PE values at the weather stations and producing a gridded map of these contour lines.

The model also simulates indirect recharge processes originating from routing surface run-off water to

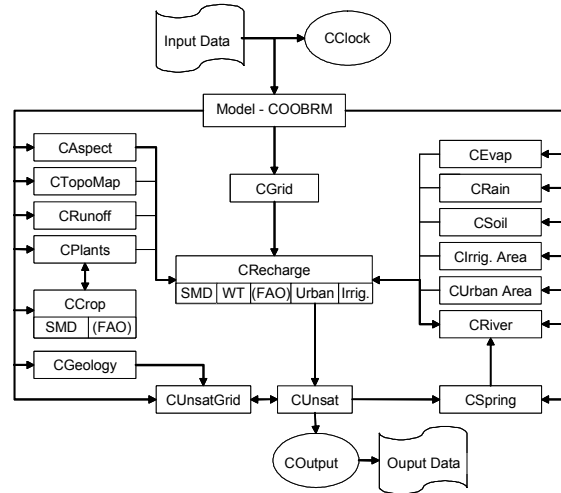

rivers and ponds, leakages through riverbeds, and routing water in the soil zone. A run-off coefficient is used to calculate run-off as a percentage of total rainfall at each node. A Digital Terrain Model (DTM) is used to provide slope aspect and route the calculated run-off from the grid node to the surface water feature. Water in the soil zone can be routed horizontally to rivers or to discharge points such as springs. A soil zone groundwater velocity, that can be varied spatially, is used for this purpose. The presence of the unsaturated zone can be taken into account in the model by including a lag between the time the estimated recharge leaves the soil zone and the time it reaches the water table. This lag time can be also varied spatially. Figure 1 illustrates the different classes of the numerical objects, prefixed with letter C, and the methods of calculations included in the model.

Figure 1. Framework of the recharge model.

RECHARGE MECHANISMS IN URBAN AREA NODES

Key recharge mechanisms identified in urban area nodes include the enhanced overland flows from buildings, car parks and roads, which increase the indirect recharge, and the direct recharge from back gardens, open spaces and parks which lose water directly from their soil zone to the saturated zone. Recharge calculations, however, are complicated by the transfer of water from one land-use type to another within the same node, for example the water movement from house roofs to back gardens.

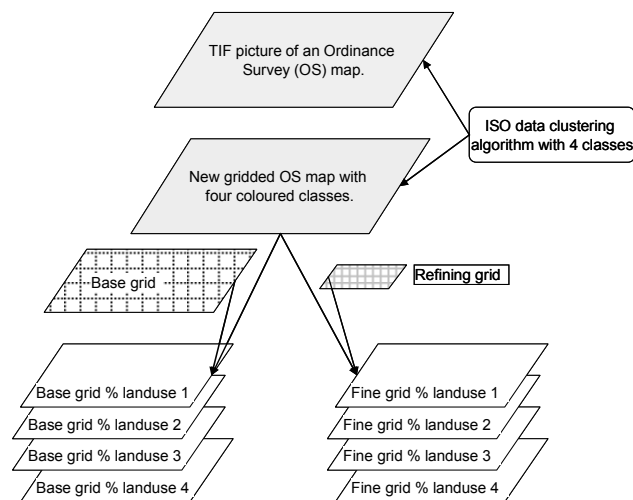

Figure 2. Calculation of the percentage land-use gridded maps.

The new recharge calculation method included in ZOODRM can deal with the following four land-use types: pavements and roads (land-use Type 1), buildings (land-use Type 2), back gardens (land-use Type 3), and parks and open green spaces (land-use Type 4). ZOODRM deals with surface water and recharge generated at the different land-use types at one node by calculating the surface run-off and recharge for each land-use type and proportioning the results using the corresponding percentage land-use values in that node. The percentage land-use values are obtained from gridded ASCII files. These gridded ASCII files are derived from Ordinance Survey (OS) maps and prepared in an ArcGIS environment using the following procedure (also illustrated in Figure 2):

1. High resolution TIF pictures of the OS map, with typical pixel size of 5 m, are imported into ArcGIS and used as gridded maps.
2. The number of classes of the output map is

specified (minimum three land-use types).

3. Isodata clustering algorithm “Iso Cluster” is used to determine the characteristics of the natural groupings of cells (using pixel colours).
4. The resulting signature file is used as the input for a classification function, such as Maximum Likelihood Classification, to produce an unsupervised classification raster (grid) that holds the defined classes only. Each 5 m pixel of this gridded map represents one land-use class.
5. Necessary corrections are undertaken to improve the gridded map.
6. Three or four gridded maps, each holding the percentage of one land-use type, are then produced for each grid resolution. The percentage of a land-use type at each grid node is calculated by dividing the total area of the land-use type (the number of pixels) in the grid node by the area of the grid node.

The numerical calculations of recharge and generated run-off at each node are then undertaken as follows:

1. Roads (land-use Type 1) receive water from rainfall and adjacent buildings. They lose some of this water as recharge and transfer the remaining water into run-off. A run-off coefficient is defined to determine the volume of water transferred to surface water courses and the volume of water infiltrated into the ground.
2. Buildings (land-use Type 2) transfer the rainfall they receive to roads (Land-use Type 1) and to gardens (Land-use Type 3) according to the following criteria:
 - a. Typically a house is bound by a road at the front and a garden at the rear. Consequently part of the rainfall will be transferred to the road and the other part will be transferred to the garden. If the area occupied by houses in a numerical urban node is equal to or greater than the area occupied by gardens half of this rainfall is transferred to back gardens. Otherwise the following formula is used to determine the fraction of rainfall transferred to the back garden:

$$K_{\text{house_Garden}} = 0.5 \times (\text{Percentage Landuse 3} / \text{Percentage Landuse 2}).$$
 The remaining fraction will be transferred to roads.
 - b. If the percentage of land-use Type 2 (houses) is greater than zero but the percentage of land-use Type 1 (roads) is zero, it is assumed that all the water transferred from houses to roads is overland run-off water, i.e. not reaching the storm sewers. This overland water is routed to the nearest river node based on the topographical gradient.
3. The conventional soil moisture deficit (SMD) method is applied to calculate the recharge over gardens (land-use Type 3). Any rainfall received from land-use Type 2 (houses) is added to the rainfall before calculating the run-off and recharge values.
4. An urban node may also include open green spaces and other specified land-use types. These land-use types can be added to the urban nodes on the condition that the SMD method applies to recharge calculations over them.

DESCRIPTION OF THE MODEL AREA

To improve the estimation of the recharge values and construct an accurate water balance it is important to include the direct and indirect recharge mechanisms occurring outside the study area. The boundary of the recharge model is therefore coincident with the boundary of the surface water catchment, which in this case is the whole Clyde Basin (Figure 3). This area is much larger than the Glasgow city boundary; however, dealing with such a large scale is possible when using ZOODRM because of its grid refinement capability. A coarse grid is laid over the whole catchment area which accounts for the key recharge mechanisms occurring outside the area of interest while refined grids are defined over the areas where high resolution recharge values are required.

The total recharge model area is approximately 3100 km² with Glasgow and its suburbs occupying the northwest part. Apart from this highly urbanised part of the recharge model, where the introduced recharge calculation method is applied, the land-use is moorland, grassland, and arable farming. Forestry and broadleaved woodlands are also present in the centre of the basin. The conventional SMD recharge calculation method is applied over these areas.

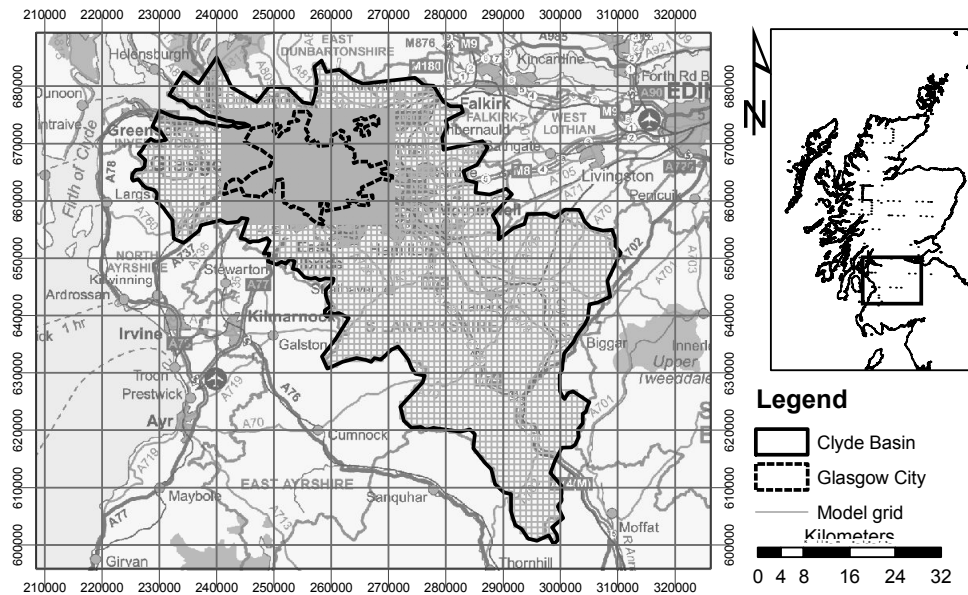

Figure 3. Recharge model covering the Clyde Basin area. (This map is based upon Ordnance Survey topographic material with the permission of Ordnance Survey on behalf of The Controller of Her Majesty's Stationery Office, © Crown copyright. Unauthorised reproduction infringes Crown Copyright and may lead to prosecution or civil proceedings. Licence Number: 100017897 [2006])

APPLICATION OF THE MODEL

A coarse model grid with 1000 m square cells is used to cover the whole Clyde Basin area. A refined grid with 100 m square cells is laid over Glasgow (Figure 3). Rainfall data at the gauging stations in the area and MORECS potential evaporation data are obtained from the Centre of Ecology and Hydrology database. Grid nodes are related to the evaporation squares and rainfall stations using Thiessen polygons. A gridded map file is used to specify the areas over which the SMD or the urban area recharge calculation methods are applied. Values for the different plants' root constants and wilting points for the SMD recharge calculation method are obtained from Lerner et al. (1990).

The CEHDTM map (Morris and Flavin, 1990) is used to derive the topographical gradient values and the aspect directions used in the surface flow routing. Major rivers and streams are included using the rivers objects of ZOODRM. It is possible to include the storm water sewers within Glasgow in the model by using these rivers objects. Indirect recharge caused by water leaking from these sewers can then be accounted for using the river leakage coefficient. The value of this leakage coefficient determines the percentage of total water, which reached the river node, lost to the underlying aquifer. At this stage of the study surface water generated within urban area nodes is assumed to reach the open rivers and streams by following the routing paths specified using the aspect directions map.

RESULTS

Figure 4 shows the recharge values calculated over the whole Clyde basin (left) and those calculated over the city of Glasgow (right). It is clear that recharge values calculated at the urban nodes are less than the recharge values calculated at the adjacent nodes where SMD method is applied. The surface run-off water, however, has increased significantly over the urban nodes. It must be noted that leakage from pressurized water mains are not included in the model. This may increase the recharge values at the urban nodes significantly.

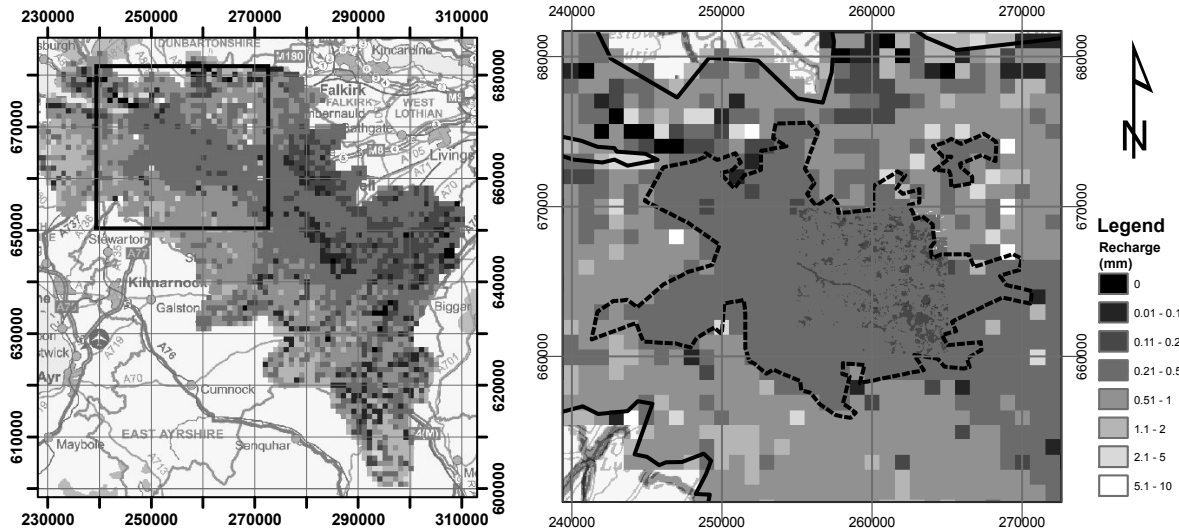

Figure 4. Recharge model results

SUMMARY AND CONCLUSIONS

A recharge calculation method that accounts for recharge processes in urban areas is developed and incorporated in the distributed recharge model ZOODRM. This method identifies four major land-use types and accounts for water transfer between these land-use types. Detailed land-use mapping has been used to calculate the percentages of the land-use types within each model node. The construction of the maps in ArcGIS environment is presented. The model is applied to calculate the recharge over the Glasgow city area, Scotland. The model area is extended to cover the whole Clyde Basin to include the recharge mechanisms taking place outside the study area. Recharge values presented here are the model first iteration results. These will be improved when the storm water networks are added and leakages from pressurised water mains are also included.

Published with the permission of the Executive Director of the BGS (NERC).

REFERENCES

- Grindley, J., 1967. The estimation of soil moisture deficits. *Meteorol. Mag.*, 96 (1137), 97-108.
- Hughes, A.G., Mansour, M.M., Robins, N.S., in press. Evaluation of distributed recharge in an upland semi-arid karst system: the West Bank Mountain Aquifer. *Hydrogeology Journal*.
- Hulme, P., Grout, M., Seymour, K., Rushton, K., Brown, L., Low, R., 2002. Groundwater resources modelling: guidance notes and template project brief (Version 1). Environment Agency, UK.
- Jackson, C.R., Spink, A.E.F. 2004. User's manual for the groundwater flow model ZOOMQ3D. British Geological Survey Internal Report no. CR/04/140N, Wallingford, U.K.
- Lelliott, M. R., Bridge, D.McC., Kessler, H., Price, S.J., Seymour, K.J., 2006. The application of 3D geological modelling to aquifer recharge assessments in an urban environment. *Quarterly Journal of Engineering Geology and Hydrogeology*. 39, 293-302.
- Lerner, D.N., Issar, A.S., Simmers I., 1990. Groundwater recharge: a Guide to understanding and estimating natural recharge. IAH, 8.
- Morris, D.G., Flavin, R.W., 1990. A digital terrain model for hydrology. *Proc 4th International Symposium on Spatial Data Handling*. 1 Jul 23-27 Zurich, 250-262.
- Penman, H.L., 1948. Natural evaporation from open water, bare soil and grass. *Proc. R. Soc. London, Ser. A*, 193, 120-145.
- Spink, A.E.F., Hughes, A.G., Jackson, C.R., Mansour, M.M., 2006. Object-oriented Design in Groundwater Modelling. MODFLOW and More 2006: Managing Ground-Water Systems – Conference Proceedings, Poeter, Hill and Zheng. Colorado School of Mines, USA.