



## Design, Construction, and Operational Plans of an Electric Paddle Wheel For a Laminated Bamboo Slats River Cruise Boat

Heri Supomo<sup>1)\*</sup>, Eko Budi Djatmiko<sup>1)</sup>, Setyo Nugroho<sup>1)</sup>, Wikaranosa Scotiandharu Supomo<sup>2)</sup>

1) Department of Naval Architecture, Faculty of Marine Technology, Sepuluh Nopember Institute of Technology, Indonesia

2) Baito Deling Research, Surabaya 60111, Indonesia

\*) Corresponding Author: [hsupomo64@gmail.com](mailto:hsupomo64@gmail.com)

### Article Info

### Abstract

#### Keywords:

river cruise boat;  
electric paddle wheel;  
laminated bamboo slats;  
carbon emission;

#### Article history:

Received: 25/11/2022  
Last revised: 23/02/2023  
Accepted: 27/05/2023  
Available online: 27/05/2023  
Published: 05/06/2023

#### DOI:

<https://doi.org/10.14710/kapal.v20i2.50503>

River cruise tourism in Indonesia has a moderately high potential as there are so many rivers in Indonesia that offer beautiful natural and urban views. However, the majority of river cruiser boats still use outboard engines, both two-stroke and four-stroke combustion engines. The working system of the outboard engine is to carry out the combustion process of the fuel oil. This combustion process usually has a loud sound, leading to noise pollutants that can harm the environment and make passengers uncomfortable. Burning fossil fuels also causes residual compounds that increase environmental pollution, especially carbon emissions. In this paper, an analysis will be carried out on the operational costs of a river cruise ship with electric paddle wheel propulsion. With a boat design with an LOA size of 5.4 m, breadth of 1.4 m, height of 0.8 m, draft of 0.3 m, and CB of 0.68, the paddle wheel diameter is 70 cm, blade width of 30cm, and six blades. The motor used to drive the paddle wheel has a power of 672.69 watts, with a battery capacity of 100 Ah. According to operational planning, benefits will be obtained, including zero carbon emissions and no noise, and operational benefits can be up to 90% greater when compared to the outboard engine drive.

Copyright © 2023 KAPAL: Jurnal Ilmu Pengetahuan dan Teknologi Kelautan. This is an open-access article under the CC BY-SA license (<https://creativecommons.org/licenses/by-sa/4.0/>).

## 1. Introduction

River cruise tourism in Indonesia has a moderately high potential if appropriately managed. This is because there are so many rivers in Indonesia that offer beautiful natural and urban views. The concept of river cruiser tourism is boarding a ship while enjoying the scenery provided [1]. Hence, the boat being ridden is also one of the essential components of this tourism.

Several rivers that used to mess up have also been revitalized to be used as river tours. Call it the Kalimas River in the city of Surabaya, the Tukad River in Bandung in the city of Denpasar, and the Cikapundung River in the town of Bandung [1]. Since the Kalimas River has been revitalized to become one of the tourist destinations in Surabaya, the number of tourists who come to ride tourist boats has increased. Every weekend, this river tour is never empty of visitors. Overall, this shows that riverside tourism is quite an attractive tourist destination among local tourists.



Figure 1. Outboard engine on river cruiser tourism boat in Kalimas River, Surabaya

But along with the rise of river tourism, there will be an environmental impact that must be considered. With the boats sailing down the river, of course, it will cause air and noise pollution. The increase in river tourism demand is not anticipated with the technological advancement of river tourism boats. Most river cruises still use materials that can harm the environment [2,3,4]. To make it worse, those boats also still use outboard engines, both two-stroke and four-stroke engines, as seen in Figure 1. The working system of the outboard engine is to carry out the combustion process of the fuel used. This combustion process usually has a loud sound, leading to noise pollutants that can harm the environment and make uncomfortable surrounding for the passenger [5]. This environmental factor is crucial because the river is part of the environment, in which many benefits for life and livelihood should not be damaged [6].

On the other hand, outboard engines generally use fossil fuels like gasoline mixed with oil. Burning fossil fuels cause residual compounds that can cause environmental pollution. The not-perfect fuel combustion process also produces exhaust emissions and energy losses. Fossil fuels contain hydrocarbon compounds. Complete combustion of these compounds will produce CO<sub>2</sub> and H<sub>2</sub>O compounds. However, if the air used in the combustion process is insufficient, it will have hazardous compounds in the form of SO<sub>x</sub>, CO, CO<sub>2</sub>, NO<sub>x</sub>, and HC compounds [5,7,8]. These compounds arise due to the presence of particles released due to the incomplete combustion process. The residue from this combustion will have the potential to exhaust gas emissions leading to environmental pollution.

This propulsion engine is a problem that must be resolved to utilize the potential of river tourism. Boats operating for river tourism must be boats with environmentally friendly propulsion engines that produce low carbon emissions. The solution that came to mind was to replace outboard engines with an electric energy-based drive to reduce the resulting carbon emissions. Electrical energy is a renewable energy that is environmentally friendly and tends to be cheaper when compared to fuel [9,10].

## 2. Methods

This research focused on applying an electric paddle wheel propulsion system on a river cruiser boat that operates on the Kalimas River, Surabaya. The design of this propulsion system includes design, fabrication, and installation. The design of the boat used as the object of research can be seen in Figure 2 and Figure 3.

Figure 2 shows the river cruiser boat lines plan used in this study. This boat has a length of All (LOA) of 5.4 m, a breadth of 1.4 m, a height of 0.8 m, a draft of 0.3 m, and a Coefficient Block (CB) of 0.68. This boat is designed to operate at the service speed of 3.5 knots. This boat is also designed with a flat sheer shape because it operates on rivers that do not require high speeds. The designed line plan also has a stable hull shape to support passenger comfort when the boat operates. The stability of this ship can be seen from the breadth of the boat, which is quite wide. In addition, the line plan is designed to accommodate the weight of the propulsion system behind the ship.

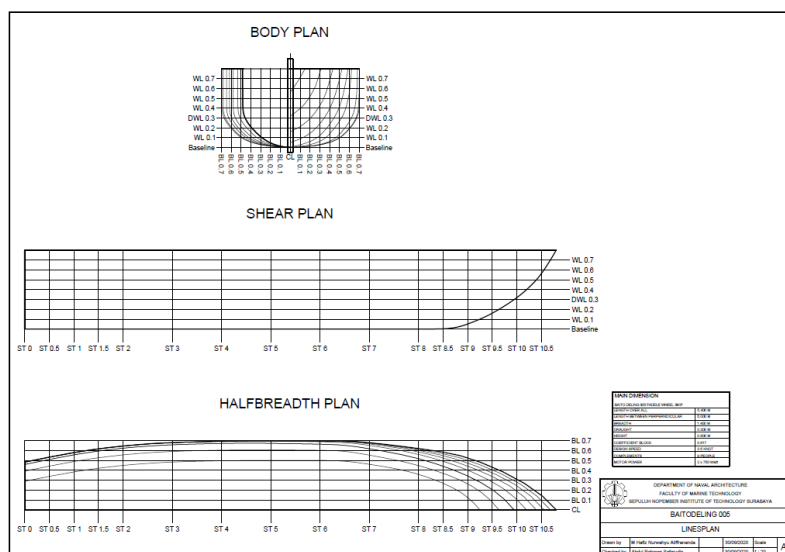

Figure 2. Lines plan of river cruiser boat

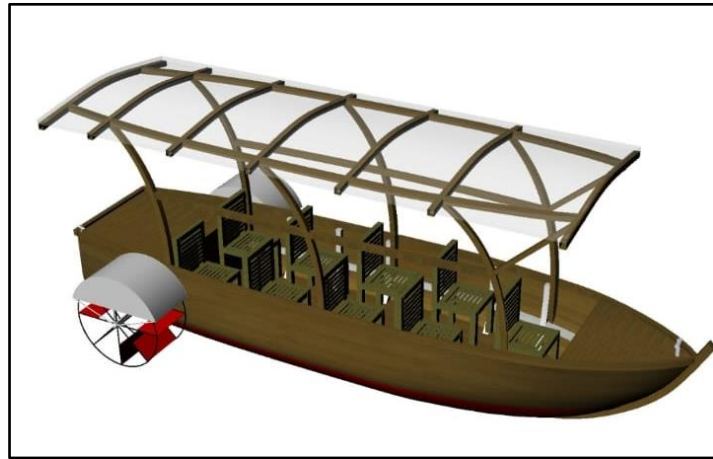

Figure 3. 3D Drawing of river cruiser tourism boat with electric paddle wheel propulsion system

This boat is designed to accommodate six passengers and one driver. There are six passenger seats arranged in two rows. The driver's seat is located at the front of the boat. Paddle Wheels are located at the rear on each side of the ship. The paddle wheel is connected to the shaft so that it can be driven by an electric motor in the engine room. The engine room has watertight openings in the upper part. These openings are useful for propulsion system maintenance and battery replacement processes. At the front of the boat is a storage cabinet that is useful for storing boat equipment, such as life jackets, mooring ropes, and other equipment. This layout can be seen clearly in the 3D drawing shown in [Figure 3](#).

In addition to the design and installation of the propulsion system, this research also focuses on calculating the economic value and the level of carbon emissions. The calculation of the economic value begins with planning the boat operation pattern and operational costs calculation. It ends with a comparative analysis of the operational costs of the outboard engine. Comparative analysis with the outboard engine was also carried out to determine the emission level between the two propulsion systems. The study aims to determine the position of the electric paddle wheel propulsion system with the outboard engine in the context of its use on a river cruiser tourism boat.

### 2.1. Paddle Wheel Design

The paddle wheel propulsion system used on this river cruiser boat is driven by an electric motor with an energy source from a battery. A paddle wheel is a propulsion system that provides thrust so the ship can move through the motion of its blade. Each blade surface pushes water when submerged and provides thrust when the paddle wheel rotates. This paddle wheel is a propulsion system suitable for ships operating on rivers because of its ability to overcome aquatic plants that can get caught in propeller-type propulsion [11].

In its use, the paddle wheel needs to be designed in such a way as to be able to move the ship efficiently. This design revolves around determining the paddle wheel's size, including the diameter, width, height, and location of the blade, as well as the position of the paddle wheel on the boat. Because the paddle wheel is driven by electricity, the size of this paddle wheel becomes an input for the needs of motor power and battery capacity. Determination of electrical specifications is very important to obtain an optimized propulsion system in achieving service speed and an operational range of the ship [9].

A ship can move when it provides a push or force against an existing resistance. In general, ships have a propulsion system that propels the boat to move. In determining a ship's propulsion system, it is necessary to calculate the power required to fight the resistance that occurs when the boat is sailing so that the ship can go according to the planned service speed. The river cruise ship that has been designed has a total resistance of 130.76 N. The calculated total resistance is a combination of all resistance, including frictional resistance, wave resistance, and viscous pressure resistance.

When the magnitude of the resistance on the ship and the desired service speed is known, then the ship's power requirements are determined to move the ship on the existing resistance at the planned speed. The first step in determining the ship's power is to calculate the effective power requirement with the following formula [9]:

$$PE = Rt \times Vs \quad (1)$$

In Formula 1, PE is the effective power of the boat where to get the PE size, the total resistance ( $R_t$ ) of 130,76 N is multiplied by service speed ( $V_s$ ) of 3.5 knots. The two components are multiplied from the known total resistance and service speed data, and the effective power required for the ship is 235.4 watts. The power requirement obtained is still an effective calculation of the need without considering the error factor beyond estimates. Therefore, the next calculation is done by adding the efficiency factor.

$$PE\% = PE/\% \quad (2)$$

In the calculation with the added efficiency value, the efficiency value used is 35%. The calculation is done by dividing the effective power by the efficiency value, as in Formula 2. After the efficiency value is added, it is known that the power required by the ship to overcome the resistance received by the boat is 672.69 Watts, equivalent to 1.05 HP.

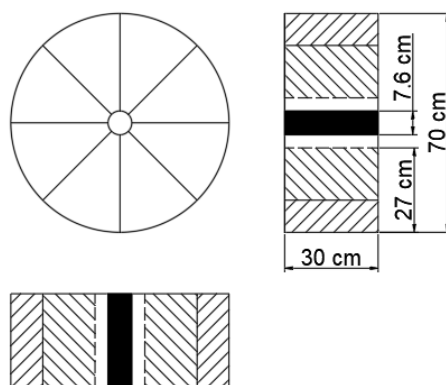

Figure 4. Paddle wheel design

The paddle wheel propulsion system rotates, so the paddle wheel's blades provide thrust. The calculation of the thrust that the paddle wheel can generate requires specification data from the paddle wheel design that has been made. In Figure 4, this paddle wheel has eight blades with a length of 30 cm and a width of 27 cm. In addition to the number of leaves, it is known that the paddle wheel has a diameter of 70 cm.

The calculation of the amount of power generated by each paddle wheel blade that is immersed in water can be generated from the multiplication of the water density of the shipping route, the coefficient of discharge, the area of the paddle wheel blades that are immersed in the water while rotating, and the relative speed which can be seen in the following formula [9,10]:

$$F = 0,5 \times \rho \times C_d \times A \times V_r^2 \quad (3)$$

F is the force on a paddle wheel blade,  $\rho$  is the density of water,  $C_d$  is the coefficient of discharge, A is the area of the blade submerged in water, and  $V_r$  is the relative velocity. Relative speed is the speed that occurs in some conditions. The condition in question is the amount of area submerged in water. This happens because the paddle wheel leaves are not always in the water when the conditions rotate. To determine the relative speed value can be calculated using the following formula:

$$V_r = V_c - V_b \quad (4)$$

$$V_r = (V_{kpl} \cdot \sin(90 - \theta)) - (V_{kpl} \cdot p) \quad (5)$$

Based on Formula 4 and Formula 5,  $V_r$  is the relative velocity resulting from subtracting the values of  $V_c$  and  $V_b$ .  $V_c$  is the value of the velocity approach on the blade with an angle of less than 90o or is not in a position perpendicular to the waterfront [9,10,11]. The value of  $V_c$  is obtained from the multiplication of the ship's speed value and the sin value from the reduction of the 90o angle and the angle of the paddle wheel blade to the waterfront. While  $V_b$  is the speed of the blade/blade resulting from the multiplication of the ship's speed and the constant "p," as stated by Antoine Parent in 1740 [12,13]. Formulas 4 and 5 are used to obtain the components of the calculation of the force generated by the paddle wheel using Formula 3, which is presented in Table 1.

Table 1. Calculation on angle variations					
Paddle-wheel blades 1					
A (m <sup>2</sup> )	Angle $\theta$	$V_c$	$V_b$	$V_r$	F
0,0897	45	1,27	0,60	0,67	20,82
Paddle-wheel blades 2					
A (m <sup>2</sup> )	Angle $\theta$	$V_c$	$V_b$	$V_r$	F
0,1794	0	1,80	0,60	0,12	132,48

Based on the calculation results observed in Table 1, it is known that a blade swinging at an angle of 0 degrees produces a thrust of 20.82 N. At the same time, a blade with an angle of 0o has a thrust of 174.12 N, so the total force generated by the paddle wheel is 174.12 N. Based on the results of the calculations in Table 1, the angle chosen for the paddle wheel blade is 0°.

## 2.2. Propulsion System Circuit

In Figure 5, it can be seen the electrical scheme planned for the paddle wheel drive system for river cruiser boats. There are several components in the ship's electrical system, namely 2 800 watt electric motors that function as paddle wheel propulsion, two electronic speed controllers that work to regulate the voltage that enters the engine so that the speed can be changed, 120 Ah 48 V battery serves to provide supply electrical energy, 2 48 V fans function as electric motor coolers, the fuse serves to cut off electricity when overloaded, the MCB acts as a protection system for the current flow of the electrical system; the throttle functions as a speed regulator for the electric motor, the power switch functions to start the electrical system so that electric motor can operate.

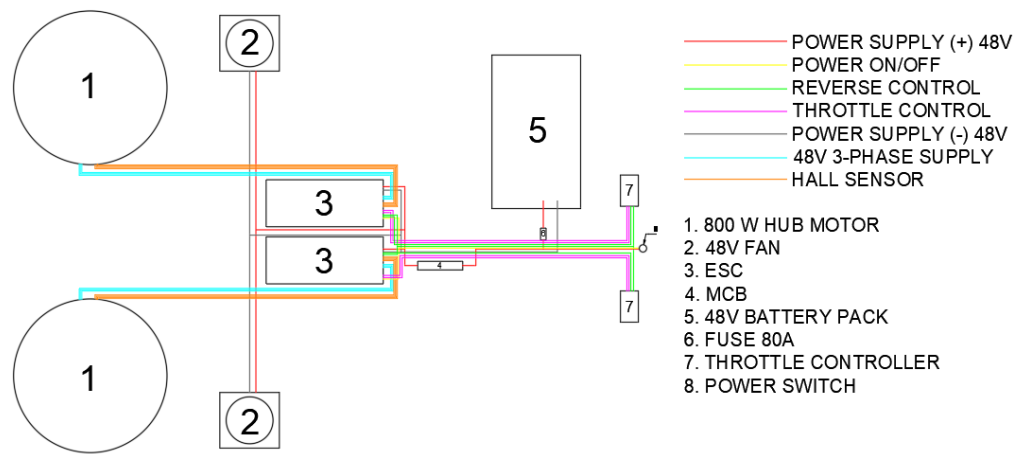

Figure 5. Wiring diagram of electric paddle wheel propulsion system

From the electrical system schematic above, electricity from the battery can flow when the power switch has been opened. Electricity from the battery will flow to the ESC and fan. The electric current from the battery received by the ESC will be channeled to the electric motor. In addition to the electric motor, the ESC is connected to the throttle so that the throttle can regulate the amount of electricity connected to the electric motor. Regulation of the amount of electricity that makes changes to the speed of the ship's speed. All electrical components that have been installed can be seen in [Figure 6](#).

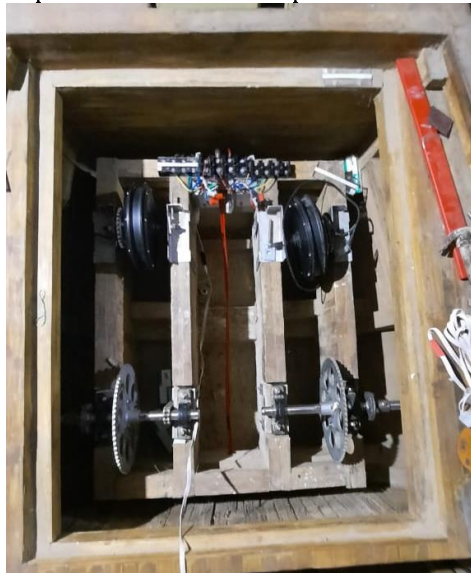

Figure 6. Installed electrical components

### 2.3. Fabrication and Installation

The fabrication of the paddle wheel begins with the construction of the frame. The paddle wheel frame is made by cutting the rebar according to the planned size. This rebar is cut into the frame's radii and the spherical outer frame. The rolling process is necessary to make the rebar into a wheel shape. Rolling is carried out manually with a simple roll tool.

The roller rebar was then assembled with another rebar with welding technology. Before welding, the pieces are set up first to ensure that the shape is precise. The setup process is carried out with the help of a spirit level, ruler, and ceramic joint grooves. This welding process is carried out using the Shielded Metal Arc Welding (SMAW) welding method ([Figure 7b](#)).

The installation of the paddle wheel leaves on this frame is carried out using the help of nuts and bolts. It is necessary to attach a bracket as a holder for the nuts. This bracket is 5 x 3 (cm) with bolt holes at the center point of the bracket. The first step in making the bracket is cutting the strip plate 20 cm long. After that, the plate is marked with a place for the bolt holes and pieces to become a 5 cm bracket. After the bracket is finished, the process continues to install the bracket on the paddle wheel frame. The marking process on the 20 cm strip plate and the process of punching holes in the plate with a drilling machine. The strip plate that has been perforated is then cut into brackets measuring 5 x 3 (cm). Since each paddle wheel blade requires at least four brackets, 64 brackets must be made. This bracket is then welded to the main frame of the paddle wheel using the SMAW welding method.



Figure 7. (a) setup process and (b) welding process of the paddle wheel frame

The paddle-wheel blade is an essential component of the propulsion system. The primary function of the paddle wheel blade is to provide momentum for the motion of the paddle wheel to move the ship. The paddle wheel blade is attached to the paddle wheel frame by bolting it to the bracket. Each paddle wheel has eight leaves of 30 cm x 27 cm, so the total leaves that must be made are as many as 16 pieces. The paddle wheel blade is made by cutting an aluminum plate with a thickness of xx mm according to the size of the blade. The aluminum plate is bent on the outer side with a bending radius of 3 mm. This is done to increase the volume of water that can be moved by the leaves so that the ship's speed can increase.

The lamination process is carried out based on the shape of the aluminum plate that has been bent. Bamboo slats are laminated on both sides of the paddle wheel with Epoxy Glue. Each side carries the lamination process with local pressure for 24 hours. After the glue has cured, the surface of the leaves must be cleaned of residual glue and leveled using a grinder.

After the blade is felt to be clean of residual glue, the cloth must be coated on the surface of the blade. This aims to increase the tightness of the leaves so that water does not seep into and touch the aluminum plate. This layer of cloth must be dried in the sun to cure before it can be applied. The finished paddle wheel leaves are then attached to the frame. This installation process is done by perforating the blade according to the point on the bracket in the frame. This installation is then carried out using nuts and bolts. The completed paddle wheel can be seen in [Figure 8](#).



Figure 8. Finished paddle wheel

Installing electrical components on the ship is carried out following the wiring diagram. There are two 800-watt electric motors on the ship's right and left stern. The electronic speed controller regulates the voltage flow between the two electric motors. In front of the electronic speed controller, there is a fuse to cut off the flow of electricity when it is overloaded, and the battery is a supplier of electric power. Besides the battery, there is a cooling system in the form of a 48 V fan. Just behind the stern bulkhead is an MCB that functions as an electric current protection system. All electrical systems located at the stern are integrated with the power switch and throttle on the ship's rudder.



Figure 9. Installed paddle wheel

Installation of the paddle wheel itself is done after the installation of shafts is finished. The shaft is needed to connect the paddle wheel to the electric motor. Each axle pipe is connected by a flange and held in place by bearings at several points. After ensuring that all axle and flange connections are aligned, the paddle wheel can be installed. The paddle wheel is installed using nuts and bolts on the flange at the end of the shaft (Figure 9). This installation is carried out precisely because it dramatically affects the movement of the paddle wheel; at the same time, it will impact the performance of the ship's motion.

#### 2.4. Operational Planning and Costing

The electric paddle wheel propulsion system is applied to a river cruiser boat operating on the Kalimas River in Surabaya. The boat operation starts at the Submarine Monument to Siola Park (Figure 10), with a capacity of six passengers. The operation was carried out in a round trip and covered approximately 4000 meters. One time this boat trip takes 22 minutes with a maximum speed of 6 knots. So, if this boat operates eight hours a day, then 22 trips can be made daily.



Figure 10. River cruiser tourism route

The limited capacity of the battery is a limitation of the boat's operational design. When the battery capacity has been used to its limit, it must be replaced or recharged so the boat can operate again. The battery capacity used in the electric paddle wheel propulsion system is 100Ah, lasting up to eight hours for 22 trips. Unfortunately, using 100% of the battery capacity continuously can cause a decrease in the battery's life. Considering this capacity limitation, the operation of this river cruiser boat requires at least two batteries that can be used interchangeably.

This river cruiser boat operation can be calculated from an economic point of view by reducing the income from tickets with the operational costs that arise. The calculation of these operational costs can be seen in Table 2. Based on these calculations, it was found that the profit from the River Cruiser boat operating on the Kalimas River is IDR 3,216,000 per month. This advantage is obtained after reducing monthly income with maintenance, crew, and battery charging costs.

Table 2. Operational cost calculation

Description	Income and outcome/month
<b>Income</b>	<b>IDR 7.776.000</b>
<b>Operational Cost</b>	
Cleaning fee	(IDR 1.500.000)
Crew fee	(IDR 2.500.000)

Charging fee	(IDR 560.000)
<b>Net Income</b>	<b>IDR 3.216.000</b>

When simulated, this river cruiser boat can accommodate 81 trips in one trip. This simulation was obtained from a survey conducted at tourist sites. Weekends (Friday, Saturday, Sunday) have the highest number of trips because visitors to tourist sites peak. The survey results found that the price of passenger tickets to enjoy the Kalimas River cruise boat is IDR 4,000 per person. With the number of passengers, as many as six people for one trip, an income of IDR 24,000 per trip. Meanwhile, if an accumulation of calculations is made based on the data on the number of trips, there will be an income of IDR 7,776,000 per month.

Later, the entire income will be used to cover operating expenses such as driver fees, power, and maintenance charges. According to Table 2, the necessary amount to pay the driver for one month is IDR 2,500,000. Approximately IDR 1,500,000 is spent each month on maintenance and cleaning in addition to driver expenses. The length of battery charging determines the price of power. kWh rates of IDR 1,699 will be multiplied by the charging time. The cost to charge the battery on this boat is IDR 13,931, and it takes about four hours to finish. According to the calculation, the battery gets charged roughly ten times over a week, costing IDR 140,000 weekly or IDR 560,000 monthly.

### 3. Results and Discussion

The boat's usage as a river cruiser tourist facility is not a new thing. Numerous excursions currently make use of boats, particularly those with outboard engines. A technical comparison analysis (Table 3) was conducted to determine the degree of advantage of the electric paddle wheel over the outboard engine. The two propulsion systems are compared based on technical aspects: environmental impact, service speed, noise, installation process, performance in the operational area, and refill or recharge process.

Based on Table 3, the electric paddle wheel propulsion system is generally superior to the outboard engine. The advantages of the outboard engine lie in the service speed and installation process. Electric paddle wheels have a low service speed due to a large amount of energy loss from the paddle wheel itself. However, the basic concept of river cruiser tourism is to ride a boat while down the river and enjoy the scenery, so high speed is not the main factor. In addition, in the installation process, the electric paddle wheel propulsion system has more system features than the outboard engine.

The main advantage of the electric paddle wheel is the absence of emissions or pollution, both carbon and sound. On the other hand, the outboard engine produces carbon emissions that are harmful to the environment and noise pollution that makes passengers uncomfortable. Both are produced from the combustion process when this engine is operating. In addition, the outboard engine propeller is also prone to snagging aquatic plants that grow a lot in the river. This risk will not arise in the electric paddle wheel propulsion system because the paddle wheel can lift aquatic plants when rotating.

Table 3. Technical comparison of electric paddle wheel and outboard engine

Aspect	Electric Paddle Wheel	Outboard Engine
Environmental Impact	Does not cause emissions because it is electric	Generates carbon emissions from burning fuel
Service Speed	3.5 knots	6 knots
Noise	Does not produce or low noise	Generates noise pollution from the combustion process
Installation Process	The installation process is quite complicated	The installation process is relatively easy
Performance in Operational Area	Does not get caught in aquatic plants	Prone to snagging aquatic plants
Refill or Recharge	Easy, just replace an empty battery with another fully charged battery	Easy, just fill the fuel tank with new fuel

This study examines the economic aspect of electric paddle wheel usage for river cruisers. This economic analysis is carried out to determine the economic value of using the electric paddle wheel and outboard engine. The purpose of this analysis is to find out the propulsion system with the most significant profit. This analysis is calculated based on operational simulations of river cruiser boats operating on the Kalimas River.

Table 4. Net income comparison

Description	Income and outcome/month	
	Electric Motor	Outboard Engine
Income	IDR 7.776.000	IDR 7.776.000
Operational Cost		
Cleaning fee	(IDR 1.500.000)	(IDR 1.500.000)
Crew fee	(IDR 2.500.000)	(IDR 2.500.000)
Energy Cost	(IDR 560.000)	(IDR 2.100.000)



Net Income	IDR 3.216.000	IDR 1.676.000
------------	---------------	---------------

Table 4 compares the monthly income for boats with outboard engines and boats with electric paddle wheel propulsion systems. It is anticipated that the income will be the same. Operational expenses, which include cleaning expenses, driver charges, and engine propulsion, account for the disparity. The main difference is energy cost. The electric paddle wheel propulsion system only requires energy expenditure (battery charging) and costs IDR 560,000 per month. This price is significantly less than outboard engines, which cost IDR 2,100,000 per month. The boat with electric propulsion will make IDR 3,260,000 in profit if this expense is divided by monthly income. The operating profit of a boat with an outboard motor is only IDR 1,676,000, which is 91% less than the electric motor profit.

The largest source of boats' carbon emissions pollutants is tourist vessels powered by combustion engines. Tour boats constantly operate for several hours, but fishing boats only require a motor system when departing for a fishing location or chart. Long-term use of outboard motors will correspond with the amount of fuel consumed and the number of carbon emissions generated. Outboard motors are currently seen on a lot of tourist vessels. An average tourist boat on the Kalimas River runs for eight hours, as was mentioned in the preceding subsection. According to these figures, 23 voyages in tourist boats powered by 25-pk outboard engines require 59 liters of RON 92 fuel.

Table 5. Carbon emission comparison

Propulsion System	Type of Fuel	Fuel Consumption (Litre/Year)	Calorie Value (TJ/Litre)	Fuel Consumption (TJ/Year)	Emission Factor (kg/TJ)	Total Emission (Ton/Year)
Outboard Engines	Gasoline	1099	0,000034	0,04	69.300	2,589
Electric Paddle Wheel	Battery	-	-	-	-	-

2.6 tons of carbon dioxide are emitted by boats with outboard engines annually, as stated in Table 5. These findings suggest that outboard motors have a significantly negative environmental impact on tourist boats. On the other hand, electric paddle-wheel tourist boats have a better effect on the environment because they do not emit carbon. No carbon emissions are produced using the battery's primary power to generate electrical energy.

#### 4. Conclusion

After conducting experiments and research, the conclusions of this study are as follows:

1. Based on ship design with a LOA of 5.4 m, a breadth of 1.4 m, a height of 0.8 m, a draft of 0.3 m, and a CB of 0.68, the paddle wheel has a diameter of 70 cm, a blade width of 30 cm, and six blades. The paddle wheel is moved by the electric motor that has a power output of 672.69 watts with a battery capacity of 100 Ah.
2. Technically, the electric paddle wheel propulsion system is superior to the outboard engine. Electric paddle wheel produces no carbon or noise pollution. In operational conditions, the electric paddle wheel can also overcome the threat of aquatic plants because the paddle wheel is unlikely to be entangled by aquatic plants. The lack of a paddle wheel in terms of speed also does not affect river cruiser tourism activities.
3. In operation, a boat that uses an electric paddle wheel propulsion system only requires energy expenditure (battery charging) only costs IDR 560,000 per month. This cost is much cheaper than outboard engines, which require IDR 2,100,000 per month. If this expense is calculated with the monthly income, the boat with electric propulsion will generate a profit of IDR 3,216,000. This profit is 91% greater than the operating profit of a boat with an outboard engine which is only IDR 1,676,000.
4. The emission computation yields an emission factor value of 69,300 kg/Tj for the propulsion system using gasoline fuel on tier 1 (IPCC default); the 25-horsepower outboard engine emits 2.6 tons of carbon dioxide annually. However, boats with electric propulsion for propulsion do not emit any carbon dioxide, as batteries and motors do not combust anything.

#### Acknowledgments

The author would like to thank all who have helped and supported completing this research, especially Baito Deling Research and Laboratory of Ship Production Technology and Management.

#### References

- [1] Tempo.co, "Wisata Susur Sungai dari Pedalaman hingga Jantung Kota", 2020, <https://travel.tempo.co/read/1312387/wisata-susur-sungai-dari-pedalaman-hingga-jantung-kota>.
- [2] M. Jastrzebska, M. Rutkowska, and W. Jurczak, "Recycling of Ships Made of Glass Reinforced Polyester," *Proceedings of the International Conference on Recycling of Ships and Other Marine Structures*, pp. 115-119, 2005.
- [3] K. Bartholomew, "Fibreglass Reinforced Plastics Recycling," *Minnesota Technical Assistance Program*, 2004.
- [4] H. Supomo, "The Use of Bamboo Slats Laminates as a Renewable Construction Material for East Java Traditional Fishing

- Boat," *Journal of Ocean Technology*, 2019.
- [5] C. Arapatsakos, A. Karkanis, and C. Anastasiadou, "The load and the gas emissions measurement of outboard engine", *International Journal of Heat and Technology*, 33(4), pp 221-228, 2015.
- [6] A. Balasubramanian, "River as an Ecosystem", *Educational Documentaries in Earth, Atmospheric, and Ocean Sciences*, 2005.
- [7] J. A. Park, C. Gardner, M. I. Chang, D. H. Kim, and Y. S. Jang, "Fuel use and green-house gas emissions from offshore fisheries of the Republic of Korea", *PloS one*, 10(8), 2015.
- [8] N. Saad, "Contribution fuel consumption of fishing vessel operation to greenhouse gas emission", *From Sources to Solution*, 343-346, 2013.
- [9] R. Rearboy, Y. Tiaple, S. Pongduang, T. Nantawong, "The Possibility of Using Electrical Motor for Boat Propulsion System", *International Conference on Alternative Energy in Developing Countries and Emerging Economics*, 2015.
- [10] K. Satpathi, "Operation and Protection of DC Shipboard Power System", *Nanyang Technological University*, 2019.
- [11] M. Masi, L. Artico, and P. Gobbato, "Study on the Reliability of Paddle-Wheel Tumble Flow Meters for High-Speed Engines", *Second International Conference on Material Science, Smart Structures and Application*, 2019.
- [12] Jones Zoë, "Domestic Electricity Generation using Waterwheels on Moored Barge", *School of the Built Environment, Heriot-Watt University*, 2005.
- [13] Sudiyono and Bambang A. "Perancangan dan Pembuatan Kapal Wisata dengan Motor Generator Listrik Tenaga Surya Sebagai Energi Alternatif Penggerak Propeler", *Jurnal Teknik Mesin Univ. Petra*. Vol. 10, No. 1, April 2008.