

Astérisque

YU. S. ILYASHENKO

Normal forms for local families and nonlocal bifurcations

Astérisque, tome 222 (1994), p. 233-258

http://www.numdam.org/item?id=AST_1994__222__233_0

© Société mathématique de France, 1994, tous droits réservés.

L'accès aux archives de la collection « Astérisque » (<http://smf4.emath.fr/Publications/Asterisque/>) implique l'accord avec les conditions générales d'utilisation (<http://www.numdam.org/conditions>). Toute utilisation commerciale ou impression systématique est constitutive d'une infraction pénale. Toute copie ou impression de ce fichier doit contenir la présente mention de copyright.

NUMDAM

Article numérisé dans le cadre du programme
Numérisation de documents anciens mathématiques

<http://www.numdam.org/>

Normal forms for local families and nonlocal bifurcations

Yu. S. Ilyashenko

INTRODUCTION

This paper deals with two closely related topics:

1. Finitely smooth normal forms for local families.
2. Bifurcations of polycycles of few- and many- parameter families. Here “few” is “no greater than 3”

The exposition is the summary of two large paper [I,Y3] and [K,S] which are to be published in the forthcoming book [I]. Therefore all the proofs are brief in this text; there detailed exposition would be found in the book, quoted above.

It appears, that for the study of nonlocal behavior of the orbits of vector field from the *topological* point of view, the *smooth* normal forms of vector field near singular points are necessary. For instance, consider a separatrix loop of a hyperbolic saddle (Figure 1).

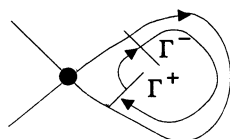

FIGURE 1

We want to know, whether the positive semiorbits winging inside the separatrix loop come *to* or *off* this loop. The topological normal form of the field near the saddle is one and the same for all the fields and give no information on the subject; it is

$$\dot{x} = x, \quad \dot{y} = -y$$

Meanwhile, the smooth normal form in the nonresonant case is

$$\dot{x} = \lambda_1 x, \quad \dot{y} = -\lambda_2 y$$

$\lambda_1 > 0$, $-\lambda_2 < 0$ are the eigenvalues of the singular point. The *correspondence map* of the entrance semitransversal Γ^+ onto the exit one Γ^- is equal to

$$\Delta(x) = x^\lambda, \quad \lambda = \lambda_2/\lambda_1$$

Suppose $\lambda \neq 1$. Then the correspondence map in the small neighborhood of O on Γ^+ has a large Lipschitz constant; in the case $\lambda > 1$ this constant tends to zero as the neighborhood contracts to a point. The smooth map from Γ^+ to Γ^- along the orbits cannot neutralize this contraction; therefore in the case $\lambda > 1$, the separatrix loop is orbitally stable from inside. In the same way, it is unstable if $\lambda < 1$.

The example motivates the study of smooth normal forms of local families.

On the other hand, the bifurcations of polycycles are closely related with to Hilbert 16th problem, as is discussed below.

§1. NUMBERS RELATED TO THE HILBERT 16th PROBLEM.

Consider a family of differential equations

$$(1) \quad \frac{dy}{dx} = \frac{P_n(x, y)}{Q_n(x, y)}$$

where P_n and Q_n are polynomials of degree no larger than the fixed constant n . The following definition is popular in the survey literature.

Definition 1. The Hilbert number $H(n)$ is the maximal possible number of limit cycles of the equation of the family (1).

It is obvious, that $H(1) = 0$. Indeed, a linear vector field has no limit cycles at all.

Nothing is known about the numbers $H(2)$; its mere existence is an open problem.

One can figure out, why Hilbert has chosen the family (1) for the study of limit cycles. In the end of the last century polynomial families gave probably the only natural example of finite parameter families of vector fields.

Now, when the mode and viewpoints have reasonably changed, generic finite parameter families became respectful. Therefore a smooth version of the Hilbert 16th problem may be stated; it is written between the lines of some text due to Arnold [AAIS].

Hilbert-Arnold conjecture. *The number of limit cycles of the equation of the typical finite parameter family (here and below “family” means “ C^∞ family of vector fields in S^2 ”) with the compact base is uniformly bounded with respect to the parameter.*

This conjecture is closely related to some nonlocal bifurcation problem. We will first state it and then recall necessary natural definitions.

Conjecture. *Cyclicity of any polycycle appearing in the typical finite parameter family is finite.*

Definition 2. A polycycle is a finite union of singular point and continual phase curves of the field which is connected and cannot be contracted along itself to any proper subset.

A limit cycle is generated by a polycycle γ in the family

$$\dot{x} = v(x, \epsilon), \quad x \in S^2, \epsilon \in B \subset \mathbb{R}^k$$

if the path $\epsilon(t)$ in the parameter space exists such that for any $t \in (0, 1]$ the equation corresponding to $\epsilon(t)$ has a limit cycle $l(t)$, continuously depending on the parameter t , $l(1) = l$, and

$$l(t) \rightarrow \gamma \text{ as } t \rightarrow 0$$

in sense of the Hausdorff distance.

Cyclicity of the polycycle in the family is the maximal number of limit cycles generated by this polycycle and corresponding to the parameter value, close to the critical one; the last corresponds to the equation with the polycycle.

Theorem (Roussarie). *The equations of the family with the compact base and the polycycles having finite cyclicity only have a uniformly bounded number of limit cycles.*

Therefore the last Conjecture implies the Hilbert-Arnold one. Some *bifurcation numbers* related to these Conjectures, are naturally defined.

Recall that a singular point of a planar vector field is called *elementary* if it has at least one nonzero eigenvalue. A polycycle is called elementary if all its vertexes are elementary.

Definition 3. $B(n)$ is the maximal number of limit cycles which can be generated by a polycycle met in a typical n -parameter family.

$E(n)$ is the maximal numbers of limit cycles which can be generated by an *elementary* polycycle in a typical n -parameter family.

$C(n)$ is the maximal number of limit cycles which can bifurcate in a typical n -parameter family from *all* the polycycles of the field, corresponding to the “critical” value of the parameter.

Conjecture. $B(n)$ exists and is finite for any n .

This Conjecture is stronger than Hilbert-Arnold one.

§2. STATEMENTS OF RESULTS.

Theorem 1 (Ilyashenko & Yakovenko). For any n the number $E(N)$ exists.

Theorem 2 (Kotova). $C(3) = \infty$.

This means that for any N one can find a generic 3-parameter family, in which some differential equation generates more than N limit cycles.

Moreover, a complete list of polycycles which can generate limit cycles and appear in generic 2 and 3- families is given; this is so called “Zoo of Kotova”, Table 1 below.

Theorem 3. $B(2) = 2$.

Theorem 4. $C(2) = 3$.

Last two theorems are due to Grosowskii, Druzkova, Chelubeev and Seregin.

Theorem 5 (Stanzo). For generic three parameter families there is a countable number of topologically nonequivalent germs of bifurcation diagrams.

In this form the Theorem 5 is an easy consequence of the Theorem 2. In fact Stanzo describes the topological and even the smooth structure of bifurcation diagrams for unfoldings of the phase portrait called “lips” (Figure 2), and constructs the invariants of the topological structure of these diagrams.

As a by product of this study a *generalized Legendre duality* is found.

Comments to the Table 1. In the Table 1 all the polycycles which can appear in the generic 2 and 3 parameter families are presented. For sure, “all” means “all equivalence classes”: the equivalence relation is as following. Two polycycles are equivalent, if they have diffeomorphic neighborhoods in \mathbb{R}^2 and a diffeomorphism of one of them to another exists which transforms one

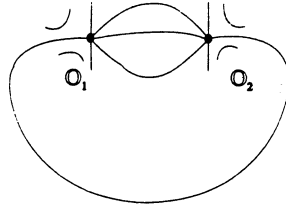

FIGURE 2. Lips

polycycle to another in such a way, that for a correspondent singular points the multiplicity and other characteristics shown in the table coincide. We do not claim, that the equivalent polycycles have equivalent unfoldings; on the contrary, for the most part of cases already investigated this is not the fact. The presence or absence of a punctured heteroclynic curve distinguishes two nonequivalent polycycles in the cell 3.9. Abbreviations in the table mean the following:

res resonant sadoble,
 k -degen degeneration in the nonlinear terms of codimension k ,
 $\int = 0$ $\int_{\gamma} \operatorname{div} v \, dt = 0$, where v is the correspondent vector field, t is time and γ is a separatrix loop.

The sign \oplus means that the correspondent case is investigated, but not published; the capital letter stands for the name of the author. In case, when the result is already published, the abbreviations mean

B Bogdanov, T Takens, L Lukianov, L-R Leontovich, Roussarie, R Reun, L.W Li Weign, DRS Dumortier, Roussarie, Sotomayor. Most part of the references may be found in [AAIS].





The authors of papers in preparation are

K Kotova, Ch Chelubeev, G Grosovski, S Seregin, St Stanzo.

They are young Moscow mathematicians.

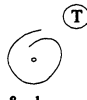
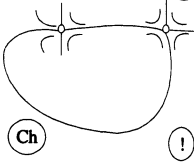
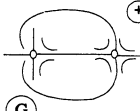
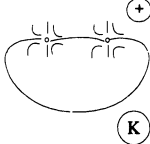
§3. NORMAL FORMS FOR LOCAL FAMILIES

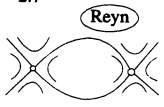
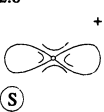
The detailed exposition is published in [IY1], therefore we give only a brief summary here.

2.1  & degen.	2.2  Ch !	2.3  G	2.4  K	2.5  Lukianov
2.6  & res. or $\int = 0$	2.7  Reyn	2.8  S	2.9  B - T	







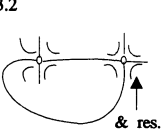
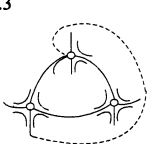
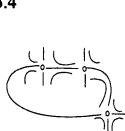
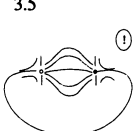
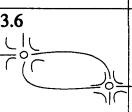
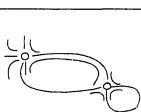
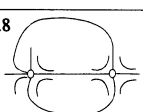
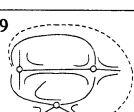
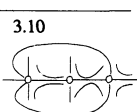
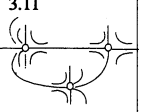
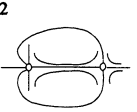
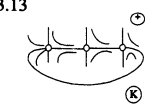
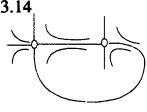
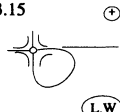

3.1  & 2-degen.	3.2  & res.	3.3 	3.4 	3.5  i
3.6 	3.7 	3.8 	3.9 	3.10 
3.11 	3.12 	3.13  K	3.14 	3.15  L,W
3.16  & 2-degen.	3.17  res. nonres.	3.18  res.	3.19  Rein	3.20 
3.21  & degen.	3.22  	3.23  $\dot{x} = x' + \dots$ K	3.24  an infinite series ...	

TABLE 1

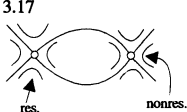
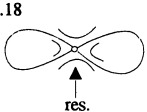
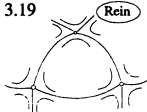
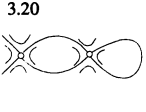
Theorem 6. 1. *The deformations of the hyperbolic germs of vector fields in a fix point which is nonresonant or oneresonant (all the resonance relations are the consequences of a single one $(\lambda, r) = 0$, $r \in \mathbb{Z}_+^n$, λ is a tuple of eigenvalues of a singular point) have polynomial integrable normal forms with respect to C^k -equivalence for any $k < \infty$.*

2. *Analogous statement holds for germs of diffeomorphisms with the only change: $(\lambda, r) = 0$ must be replaced by $\lambda^r = 0$, where λ is a tuple of multo-
plicators of the fix point.*

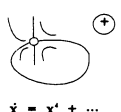
3. *Deformations of saddlenodes of vector field in \mathbb{R}^n (one eigenvalue is zero) having finite multiplicity and no supplementary resonances are C^k equivalent for any k to the linear suspension over one dimensional polynomial integrable family.*

The explicit formulae are listed in [IY1], and we shall not repeat it here. Note that the elementary singular points of the planar vector fields fall under conditions of the previous theorems. The list of finitely smooth normal forms of their unfoldings will be given in §6 and used below.

The above theorem exhausts the positive results of this kind. Unfoldings in the other cases corresponding to the codimension one degenerations has functional module of smooth classification, or have no reasonable classification at all.

Theorem 7. [IY2] 1. *Typical one parameter deformation of germs of one dimensional diffeos with multiplier $\lambda = 1$ or $\lambda = -1$ has the functional modules of C^1 -classification.*

2. *The same is true for the Andronov-Hopf families: deformations of planar vector fields with $\lambda_{1,2} = \pm i\omega$, $w \neq 0$.*

The modules in the above theorem are explicitly described.

The deformations of saddle suspensions over the above families are finitely smooth equivalent to linear suspensions over these families.

The result form the end of the long chain built by Belitski, Bogdanov, Brjuno, Dumortier, Kostov, Roussarie, Samovol, Takens. See [B], [Bo], [Br], [D], [K], [R], [S], [T].

§4. LIPS OR WHY $C(3) = \infty$?

Consider a vector field in \mathbb{R}^2 having two saddlenodes O_1, O_2 of multiplicity two and a saddle connection, like it is shown in Figure 2. These three requirements produce a vector field with degeneration of codimension 3.

Theorem 8 (Kotova). For any N in a typical 3 parameter family such a vector field with “lips” may be met that its unfolding will have the equations with more than N limit cycles.

Remark. This theorem immediately implies Theorem 2.

Sketch of the proof. The finitely smooth orbital versal deformation of a saddlenode of multiplicity two has the form [IY1]:

$$\begin{aligned} \dot{x} &= (x^2 + \varepsilon)(1 + ax)^{-1} \\ \dot{y} &= \pm y \end{aligned}$$

Consider the unfolding of “lips”. After the suitable reparametrization and coordinate change near saddlenodes one obtain the following local systems near O_1 and O_2 respectively (see Figure 2):

$$(4.1) \quad \begin{aligned} \dot{x} &= (x^2 + \varepsilon)(1 + a(\bar{\varepsilon})x)^{-1}, \quad \dot{y} = -y \\ \dot{x} &= (x^2 + \delta)(1 + b(\bar{\varepsilon})x)^{-1}, \quad \dot{y} = y \end{aligned}$$

where $\bar{\varepsilon} = (\varepsilon, \delta, \lambda) \in (\mathbb{R}^3, 0)$ and $\lambda = 0$ corresponds to the saddle connection.

Now consider the *limit cycle equations*. This will be an equation for the fix points of the Poincaré map; written in the appropriate form. For this sake decompose the Poincaré map for the unfolding of the polycycle, in the domain, where it is defined, into the composition of the four maps, shown in the figure 3.

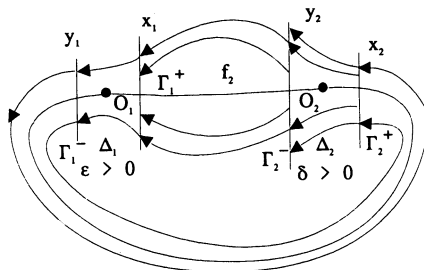

FIGURE 3

The transversals Γ_1^+, Γ_1^- are taken in the neighborhood of the point O_1 , where the normalizing chart for the local family is defined. Let Γ_1^+ be the entrance and Γ_1^- the exit transversal through which the phase curves enter in and come off the mentioned neighborhood of O_1 . Let x_1 and y_1 be restrictions of the y -function of the normalizing chart to Γ_1^+ and Γ_1^- respectively. Then the *correspondence map*

$$\Delta_1 : \Gamma_1^+ \rightarrow \Gamma_1^-$$

along the phase curves will take the form

$$\begin{aligned} \Delta_1(x_1) &= y_1, \quad y_1 = C_1(\varepsilon)x_1 \\ C_1(\varepsilon) &\rightarrow 0 \text{ as } \varepsilon \rightarrow 0 \end{aligned}$$

This map is called the *funnel*. In fact

$$\begin{aligned} C_1(\varepsilon) &= \phi(\varepsilon) \exp\left(-\frac{\pi}{\sqrt{\varepsilon}}\right) \\ \Phi(\varepsilon) &= \exp \frac{2}{\sqrt{\varepsilon}} \left(-\frac{\pi}{2} + \arctan \frac{1}{\sqrt{\varepsilon}}\right) = O(1). \end{aligned}$$

An analogous construction near the point O_2 gives the transversals Γ_2^+, Γ_2^- with the charts x_2, y_2 and the correspondence map

$$\begin{aligned} \Delta_2(x_2) &= y_2, \quad y_2 = C_2(\delta)x_2, \quad C_2(\delta) \rightarrow \infty \text{ as } \delta \rightarrow 0, \\ C_2(\delta) &= (\phi(\delta))^{-1} \exp \frac{\pi}{\sqrt{\delta}} \end{aligned}$$

The map Δ_2 is called is *shower*.

There are also two regular maps along the phase curves depending on $\bar{\varepsilon}$ as a parameter:

$$f_{\bar{\varepsilon}} : \Gamma_1^- \rightarrow \Gamma_2^+ \text{ and } g_{\bar{\varepsilon}} : \Gamma_2^- \rightarrow \Gamma_1^+.$$

The Poincaré map $\Delta : \Gamma_1^+ \rightarrow \mathbb{R} \supset \Gamma_1^+$ for any fixed $\bar{\varepsilon}$ is a composition

$$\Delta = g_{\bar{\varepsilon}} \circ \Delta_2 \circ f_{\bar{\varepsilon}} \circ \Delta_1$$

The limit cycle equation has the form

$$\Delta(x) = x,$$

or equally

$$(4.2) \quad \Delta_2 \circ f_{\bar{\varepsilon}} \circ \Delta_1 = g_{\bar{\varepsilon}}^{-1}$$

The last equation will be studied below.

Note that the function $g_{\bar{\varepsilon}}$ is not a germ but an actual function on a segment. The situation completely loses locality and, therefore, the following construction goes.

Chose the curve

$$\gamma = \{\bar{\varepsilon}(\varepsilon)\}, \quad \bar{\varepsilon}(\varepsilon) = (\varepsilon, \delta(\varepsilon), \lambda(\varepsilon)), \quad \lambda(\varepsilon) \equiv 0,$$

with the endpoint zero in the parameter space such that

$$\begin{aligned} f_{\bar{\varepsilon}}(x_1) &= 0 \text{ for } x_1 = 0, \quad \bar{\varepsilon} = \gamma(\varepsilon), \\ C_1(\varepsilon)C_2(\delta(\varepsilon)) &\equiv 1 \end{aligned}$$

The left hand side of (4.2) for small ε will be the rescaling \tilde{f}_{ε} of the smooth function $f_{\gamma(\varepsilon)}$ with $f_{\gamma(\varepsilon)}(0) = 0$:

$$\tilde{f}_{\varepsilon}(x_1) = C^{-1}(\varepsilon) \circ f_{\gamma(\varepsilon)} \circ C(\varepsilon)(x_1)$$

The limit of the rescaled smooth function with the zero value in zero is linear. The Figure 4 shows that for a function $g_{\bar{\varepsilon}}$ properly chosen the limit cycle equation (4.2) for $\bar{\varepsilon} = 0$ may have a prescribed number of solutions, and a situation is structurally stable.

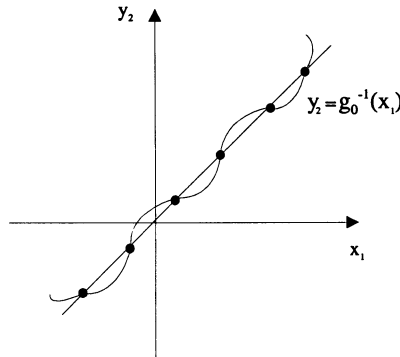

FIGURE 4

This proves the Theorem 8.

§5. BIFURCATION DIAGRAM FOR THE “LIPS”
AND GENERALIZED LEGENDRE DUALITY.

In the first half of this section the bifurcation diagram for “lips” will be described. This will give the sketch of the proof of the Theorem 5.

5.1 Bifurcation diagram and Legendre transformation.

Recall that the point in the parameter space of the family of vector fields belong to the bifurcation diagram if the corresponding vector field is not structurally stable in its domain.

We will describe the intersection of the bifurcation diagram (BD) for “lips” with the narrow funnel U centered on the curve

$$\varepsilon = \delta, \lambda = 0$$

Let

$$(5.1) \quad \delta_1 = \frac{\delta - \varepsilon}{\varepsilon^{\frac{3}{2}}}, \lambda_1 = \frac{\lambda}{\exp(-\sqrt{\varepsilon})}$$

$$U = \{(\varepsilon, \delta, \lambda) | \delta_1 \in \sigma, \lambda_1 \in \sigma\}$$

Here $\sigma = [-A, A]$ is such a segment, that

$$A \gg \max |g_{\bar{\varepsilon}}^{-1}|, A \gg \max (g_{\bar{\varepsilon}}^{-1})'$$

Let $(\varepsilon, \delta_1, \lambda_1)$ be the new coordinates in U . Consider only those point on the BD which correspond to semistable limit cycle. Fix a small value of ε . The limit cycle equation (4.2) has the form

$$(5.2) \quad C_2(\delta) f_{\bar{\varepsilon}}(C_1(\varepsilon)x) = g_{\bar{\varepsilon}}^{-1}(x)$$

Suppose that ε runs the curve in U having a definite limit point $(0, \delta_1, \lambda_1)$ in the chart $(\varepsilon, \delta_1, \lambda_1)$, see (5.1). Then the solution of (5.2) $g_{\bar{\varepsilon}}^{-1}$ is given by the intersection of the graph of $f_{\bar{\varepsilon}}$ and the rescaled graph of $f_{\bar{\varepsilon}}$ which is almost a straight line. When the parameters δ_1, λ_1 change, these “almost straight lines” changes also; the bifurcation diagram contains the points corresponding to the tangency of these graphs (Figure 5).

In the case, when $\varepsilon = 0$, the set of parameters (δ_1, λ_1) , corresponding to the tangencies (2) on the Figure 5, will form the part of the “blown up vertex”

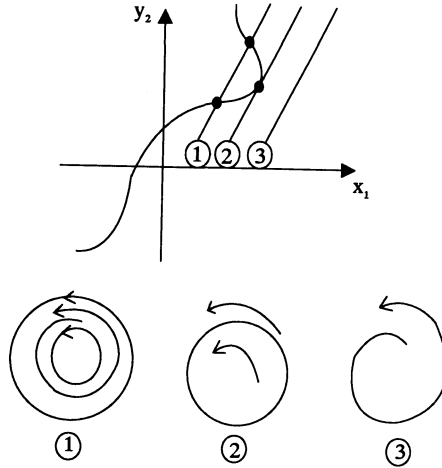

FIGURE 5

of BD in the funnel U . This set will be the Legendre transformation of the graph of g_0^{-1} on the parameter plane (a, b) of the straight lines

$$y_2 = ax_1 - b,$$

$$b = -\lambda_1, \quad a = f'_0(0) \exp\left(-\frac{\pi}{2} \delta_1\right)$$

The last formulae may be easily obtained analyzing the rescaling in the left hand side of (5.2).

Therefore, the intersection $BD \cap U$ contains a surface, which becomes diffeomorphic to a cylinder over the Legendre transformation of a graph of g_0^{-1} after the blowing up (5.1). This proves the Theorem 5, §2.

Now discuss the intersection

$$\Sigma = BD \cap U \cap \{\varepsilon = \varepsilon_0\}, \quad \varepsilon_0 > 0$$

Then the lines would be replaced by the curves, still forming the two parameter family; the parameter values corresponding to tangency with the graph of g_0^{-1} belong to Σ . This intersection is equal, up to some details, to

the generalized Legendre transformation of the graph of Σ . First recall some classical definitions [A].

5.2. Dual second order differential equations..

Definition 4. A two parameter family of curves in the plane is the divergent diagram of maps:

$$(5.3) \quad \mathbb{R}^2 \xleftarrow{\phi} \Omega \xrightarrow{\psi} \mathbb{R}^2, \quad \Omega \subset \mathbb{R}^3$$

Remark. In the generic case near a typical point \mathcal{O} of Ω both maps φ and ψ are regular (have rank 2). Consider the set $\psi(\Omega) = \{(a, b)\} \subset \mathbb{R}^2$ as a space of parameters and the set $\varphi(\Omega) = \{(p, q)\} \subset \mathbb{R}^2$ as a phase space. The level curves of the germ $\psi : (\Omega, \mathcal{O}) \rightarrow (\mathbb{R}^2, \mathcal{O}_1)$, $\mathcal{O}_1 = \psi(\mathcal{O})$ form the germ of a one dimensional foliation in \mathbb{R}^3 . The image of this foliation under the map ψ is the two parameter family of plane curves (in the naive sense), see Figure 6a.

Remark. Let (t, a, b) be the local chart near \mathcal{O} , and let $\varphi = (\varphi_1, \varphi_2)$. Denote by dot the derivation with respect to t along the level curves of $\psi : a = \text{const}, b = \text{const}$ in (Ω, \mathcal{O}) . Then the function

$$p = \frac{\dot{\varphi}_2}{\dot{\varphi}_1}$$

is the derivative of a function $y = f(x)$ with the graph $\varphi(\psi^{-1}(a, b))$ for suitable a and b . The function $\frac{d^2 f}{dx^2}$ may be also expressed through a, b, t, φ_1 , and φ_2 as a function q on (Ω, \mathcal{O}) . But in the generic case functions x, y, p form a chart in (Ω, \mathcal{O}) . Therefore one can write

$$q = \Phi(x, y, p)$$

The curves $\{\varphi(\psi^{-1}(a, b) \mid (a, b) \in \psi(\Omega, \mathcal{O})\}$ are the graphs of the solutions of the differential equations

$$(5.4) \quad y'' = \Phi(x, y, y')$$

Therefore, in a generic case, the diagram (5.3) near a genetic points, gives a germ of a second order differential equation.

Definition 5. The local second order differential equation is the genetic diagram (5.3) near a regular point of a map ψ , with the phase space $\text{Im } \varphi$ and a parameter space $\text{Im } \psi$.

Now define the differential equation *dual* to the previous one. For this sake we should nearly change the roles of the maps φ and ψ .

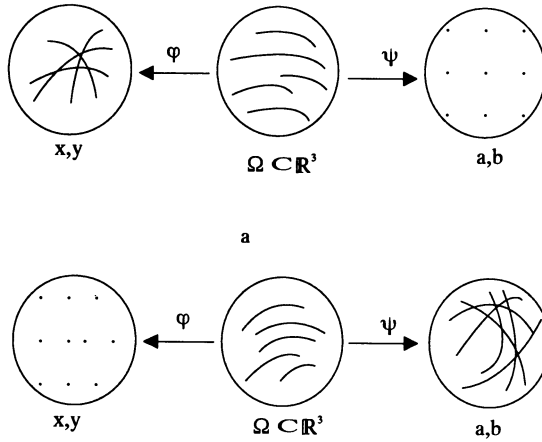

FIGURE 6

Definition 6. The second order differential equation dual to the one described in definition 5, is the same diagram (5.3) considered near a regular point of a map φ with the phase space $\text{Im } \psi$ and a parameter space $\text{Im } \varphi$ (see Figure 6 b)

5.3. Generalized Legendre duality.

The definition of the generalized Legendre duality is naturally realized with the constructions of the Figure 5.

Definition 7. The generalized Legendre transformation of the planer curve γ with respect to the family (5.3) with the parameter space $\text{Im } \psi$ is the set $\hat{\gamma}$ of the parameters $\alpha = (a, b)$ such that the curves

$$\gamma \text{ and } \varphi(\psi^{-1}(\alpha))$$

are tangent.

Remark. For the family

$$y = ax - b$$

(the maps φ and ψ have the form

$$(x, ax - b) \xleftarrow{\varphi} (a, b, x) \xrightarrow{\psi} (a, b)$$

the definition 7 give the classical Legendre transformation. The following theorem is a classical.

Theorem [A]. *The Legendre transformation is an involution for the genetic germ of a curve γ . Then means that the curve $\hat{\gamma}$ obtain from γ gives the same curve γ after a Legendre transformation.*

The equivalent statement: the Legendre transformation is the inverse to itself on the set of genetic germs of curves.

Theorem 9. (Stanzo). *The generalized Legendre transformations with respect to dual two parameter families, in sense of Definition 6, are inverse to each other on the set of genetic germ of plane curves.*

Remark. The first proof of this theorem was given by Stanzo and will be published in [K,S]. Here I reproduce the proof, proposed by Cromov *without looking to the explicit statement of the theorem*. I allow myself to reproduce here approximately a fragment of our conversation. I ask Gromov, does he know the fact called the “Generalized Legendre duality”. He says “ I don’t, but the proof must be similar to the classical one. The crucial point is, that the curves of the first family passing through one and the same point correspond to the curve of the dual family on the parameter plane. Let me find the proof in some classical book, for the traditional Legendre transformation”. We try to find it in some books of Klein and fail. “Well, – says Gromov, – in this case of lines it looks like what follows” – and he gave a sketch of the proof of the theorem [A], which will be extended below to the general context.

This proof is based on incidence reasons only. We will give a sketch of it using the consequences of some genericity assumptions without formulating them explicitly.

The principal fact used below is that the tangent line is the limit of chords. Similarly, the curve of the two parameter planar family tending to some curve γ in a point α , is a limit of the “chordal” curves of the family passing through the points α and β , where β is the point of the same curve γ tending to α .

Consider two dual families of planar curves given by diagram (5.3). Define by A, B, \dots points on $\text{Im } \psi$. Let Φ and Ψ_A be the curves of the dual families, correspondent to the parameter values A and α respectively:

$$\Phi_\alpha = \varphi(\psi^{-1}(\alpha)), \quad \Psi_A = \psi(\varphi^{-1}(A)).$$

Let

$$\begin{aligned} \tilde{\Phi}_\alpha &= \psi^{-1}(\alpha), \quad \tilde{\Psi}_A = \varphi^{-1}(A), \\ \Phi &= \{\Phi_\alpha \mid \alpha \in \text{Im } \psi\}, \quad \psi = \{\Psi_A \mid A \in \text{Im } \varphi\} \end{aligned}$$

Take a curve $\gamma \subset \text{Im } \varphi$, a point $A \in \gamma$ and a curve $\Phi_\alpha \in \Phi$ tangent to γ at a point A . Let γ^* be the generalized Legendre transformation of γ with respect

to the family Φ . We want to prove that the curve of the family Ψ tangent to the curve γ^* in the point α is ψ_A , that is to say, corresponds to the point A . This will give the desired duality.

Instead of this study the “chordal” curve; the curve of the family Ψ passing through α and the nearby point $\beta \in \gamma^*$. Let C be corresponding point of $\text{Im } \varphi$:

$$\Psi_C \ni \alpha, \beta; \Psi_C = \psi(\varphi^{-1}(C)).$$

The point β corresponds, by definition of γ^* , to the curve Φ_β of the family Φ , tangent to γ in the point B close to A . We state that the point C corresponding to the “chordal” curve Ψ_C is to the point of intersection of Φ_α and Φ_β (see Figure 7). Indeed, the curve

$$\tilde{\Psi}_C = \varphi^{-1}(C)$$

has a non empty intersections with the curves

$$\tilde{\Psi}_\alpha = \psi^{-1}(\alpha) \text{ and } \tilde{\Psi}_\beta = \psi^{-1}(\beta)$$

because these curves form the total inverse image of α and β with respect to the map ψ , and the curve $\psi(\tilde{\Psi}_C)$ contains α and β . Therefore the image

$$C = \varphi(\tilde{\Psi}_C) \text{ belongs to } \Phi_\alpha = \varphi(\tilde{\Psi}_\alpha) \text{ and } \Phi_\beta = \varphi(\tilde{\Psi}_\beta).$$

This means that the point C is the intersection point of Φ_α and Φ_β .

On the other hand C tends to A , as B tends to A . This proves the theorem.

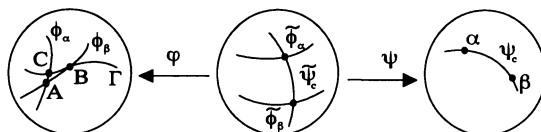

FIGURE 7

Remarks. 1. The generalized Legendre duality may be extended to higher dimensions.

2. After my talk in the conference on Dynamical systems in Triest, June 92, Zakalukin communicated me that this generalized Legendre duality may be derived from some of his recent results (though the statement was unknown to him before).

§6. BIFURCATIONS OF ELEMENTARY POLYCYCLES.

In this section the weakened version of the Theorem 1 is discussed.

6.1 Statement of result and four steps of the proof.

Theorem 10 (Ilyashenko & Yakovenko). *An elementary polycycle met in a typical finite parameter family generates only finitely many limit cycles in this family.*

We will give the brief sketch of the proof here; the detailed exposition is given in [IY3]. This proof splits into four steps.

Step I. Replace the Poincaré equation for limit cycles (the equation for fix points of the monodromy map) by the functional-Pfaffian system with the polynomial Pfaffian equations. This step uses the normal polynomial forms for the unfoldings of elementary singular points mentioned in §3 and summarized in the Table 2 below. The Poincaré equation is singular: its right hand side is not defined in the full neighborhood of zero point in the space of phase variables and parameters. The functional-Pfaffian system is regular in a likely neighborhood.

Step II. Replace the functional-Pfaffian system by purely functional system which is regular in the entire neighborhood of zero. This is done using the Khovanskii procedure [Kh].

Step III. Generalize Gabrielov finiteness theorem from real analytic to finitely smooth case. This means, find a sufficient property for finitely smooth maps of real manifolds with boundary to have a uniformly bounded number of universe images of the regular value of the map. This leads to the definition of the so called *nice maps*.

Step IV. The Khovanski procedure reduces the estimate of the cyclicity of elementary polycycle of the upper estimate of the regular solutions of the so called “special chain map”. The simplest, not exactly the necessary one, example of the special chain map is the following:

$$(6.1) \quad g = P \circ f, \quad f : B \rightarrow \mathbb{R}^N, \quad P : \mathbb{R}^N \rightarrow \mathbb{R}^n,$$

$B \subset \mathbb{R}^n$ is a ball; f is generic, P is polynomial.

Theorem 11 [IY3]. *For any fixed polynomial P and for generic f , the map (6.1) is nice.*

We will now explain these four steps in more details.

6.2 Step I. Reduction to functional-Pfaffian system.

Theorem 12 [IY3]. *The generic unfoldings of elementary singular points of the vector fields in the plane are finitely smooth equivalent to ones listed in the Table below. The correspondence maps for these unfoldings satisfy the Pfaffian equations listed in the column 3 of the same table.*

Type	Normal form	Pfaffian equation for the correspondence map
Nonresonant saddle	$\dot{x} = x,$ $\dot{y} = -\lambda(\varepsilon)y, \lambda > 0$	$x dy = \lambda(\varepsilon)y dx \quad x > 0, y > 0$
Resonant saddle	$\dot{x} = x(\frac{m}{n} + f_\mu(u, \varepsilon)),$ $\dot{y} = -y, u = x^m y^n$ is the resonant monial, $f_\mu = P_{\mu-1} \pm$ $u^\mu(1 + a(\varepsilon u^\mu))$ $P_{\mu-1}(u, \varepsilon) = \varepsilon_1 + \varepsilon_2 u +$ $\dots + \varepsilon_\mu u^{\mu-1}$	$(f_\mu(x^m, \varepsilon) - mx^m)f_\mu(y^n, \varepsilon)dx$ $+ nxy^{n-1}f_\mu(x^m, \varepsilon)dy = 0$ $x > 0, y > 0$
Degenerated elementary singular point (saddlenode)	$\dot{x} = g_\mu(x, \varepsilon),$ $\dot{y} = -y$ $g_\mu = P_{\mu-1}(x, \varepsilon) \pm x^{\mu+1} \cdot$ $(1 + a(\varepsilon)x^\mu), P_{\mu-1}$ is the same as before	a. $x dy = y dx$ <hr/> b. $g_\mu(x, \varepsilon)dy - y dx = 0,$ $y > 0$

TABLE 2

Commentary. The case **a** in the third row of the Table corresponds to the map of the transversals crossing the central manifold.

The case **b** corresponds to the map of the segment transversal to the stable manifold onto segment transversal to the central one.

Let now γ be an elementary polycycle met in a typical k -parameter family. Denote by

$$\Delta : (x, \varepsilon) \mapsto \Delta(x, \varepsilon)$$

the Poincaré map of this polycycle defined for some domain in the space of phase variable x on transversal and parameter ε . This domain contains in its closure zero point corresponding to the polycycle. The limit cycle equation has the form

$$(6.2) \quad \Delta(x, \varepsilon) = x$$

Our goal is to prove the existence of the upper estimate for number of solutions of this equation. The solution of (6.2) is intersection point of the cycle with

transversal Γ , see Figure 8. Replace this equation by the system corresponding to the intersection points of the limit cycles generated by γ with transversals separating the singular points $\mathcal{O}_1, \dots, \mathcal{O}_n$ from the other part of the polycycle, Figure 8.

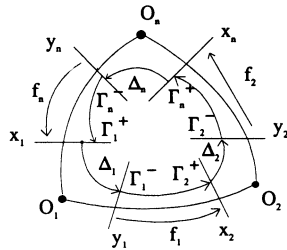

FIGURE 8

Let Γ_j^+ and Γ_j^- be the entrance and exit transversals in the neighborhood of the point \mathcal{O}_j . Let Δ_j be the correspondence map of Γ_j^+ to Γ_j^- . Consider the normalizing charts near the singular points, see Table 2. Let x_j, y_j be the restrictions of the appropriate coordinate functions of these charts to Γ_j^+ and Γ_j^- respectively. Then the equation (6.2) may be replaced by the system

$$\begin{aligned}
 y_1 &= \Delta_1(x_1, \varepsilon) \\
 x_2 &= f_1(y_1, \varepsilon) \\
 &\dots \\
 y_n &= \Delta_n(x_n, \varepsilon) \\
 x_1 &= f_n(y_n, \varepsilon)
 \end{aligned}
 \tag{6.3}$$

Traditionally the correspondence equations bring the main difficulties. After the Table 2 is written down they become standard. The explicit formulae for them may be derived from this table. What about the functions f_j , we only know that they are regular and generic.

The correspondence maps Δ_j are solution of the Pfaffian equations from the Table 2. Replace these maps in the system (6.3) by the correspondent equations; we will obtain the system

$$\begin{aligned}
 \omega_1(x_1, y_1, \varepsilon) \\
 x_2 &= f_1(y_1, \varepsilon) \\
 &\dots
 \end{aligned}
 \tag{6.4}$$

The 1-forms ω_j have the polynomial coefficients with respect to x and ε . This is the end of the step I.

Step II. Khovanskii procedure..

This procedure allows to replace Pfaffian equations once more by the “functional” ones, but the system constructed this time appears to be regular. The algorithm is described in [Kh], its realization may be found in [IY3]. The following system is obtained as a result

$$(6.5) \quad \mathcal{F}(j_c^n f, \varepsilon) = a$$

Here

$$(6.6) \quad f(y, \varepsilon) = (f_1(y_1, \varepsilon), \dots, f_n(y_n, \varepsilon)),$$

$\varepsilon = (\varepsilon_1, \dots, \varepsilon_k) \in B$ is a parameter, B is a ball in \mathbb{R}^k . The notation on the left hand side of (6.5) is explained by the following

Definition 8. Let C (C of Cartesian) denote the space of all maps

$$f : (\mathbb{R}^{n+k}, 0) \rightarrow (\mathbb{R}^n, 0)$$

of the form (6.6). The (n, C) jet of the map (6.6) in a point (y, ε) is the set of maps (6.6) (maps from the space C) which difference with f is n -flat in the point (y, ε) . The space of all jets $j_c^n f$, $f \in C$ is denoted by J_C^n .

The map \mathcal{F} is polynomial:

$$\mathcal{F} : \mathbb{R}^N \rightarrow \mathbb{R}^{n+k}$$

for appropriate N . Next two steps allow to prove that the map (6.5) has a uniformly bounded number of regular inverse images of any of its regular values.

6.4. Step III. Finitely smooth maps with Gabrielov property..

The following theorem of Gabrielov is well known.

Theorem [G]. *Let M be a compact analytic set in the real space and $g : M \rightarrow \mathbb{R}^m$ an analytic map. Then for any $a \in \mathbb{R}^m$ the number of connected components of the inverse image $g^{-1}(a)$ is uniformly bounded with respect to a .*

If the map (6.5) would be analytic, then the system (6.5) would have a uniformly bounded number of isolated solutions by the previous theorem. Unfortunately, the map (6.6) is only finitely smooth. In the general case the

Gabrielov theorem for finitely smooth maps is obviously wrong. We must find the sufficient local conditions for the finitely smooth map to have a uniform bound for the number of the inverse images of any of its regular values. These sufficient conditions were obtained analyzing the original proof of the Gabrielov theorem.

Analytic sets form the so called stratified manifolds [W], [M]. Therefore we will consider the smooth ones, referring to the necessary definitions in [M].

Let M be a stratified manifold. Denote by $\text{sk } M$, the *skeleton* of M , the union of its strata of all the dimensions lower than the maximal one; the last is called *the dimension of M* . Consider a complete flag in \mathbb{R}^m with the orthogonal projections π_j :

$$(6.7) \quad \mathbb{R}^m \xrightarrow{\pi_m} \mathbb{R}^{m-1} \rightarrow \dots \rightarrow \mathbb{R}^1 \xrightarrow{\pi_1} \mathbb{R}^0 = \{0\}$$

Definition 9. The map $g : M \rightarrow \mathbb{R}^m$ of m -dimensional compact stratified manifold in \mathbb{R}^m is called nice if a flag (6.7) and a commutative diagram

$$(6.8) \quad \begin{array}{ccccccc} M^m & \xleftarrow{i_m} & M^{m-1} & \xleftarrow{i_{m-1}} & \dots & \xleftarrow{i_2} & M^1 & \xleftarrow{i_1} & M^0 \\ g_m \downarrow & & g_{m-1} \downarrow & & & & g_1 \downarrow & & g_0 \downarrow \\ \mathbb{R}^m & \xrightarrow{\pi_m} & \mathbb{R}^{m-1} & \xrightarrow{\pi_{m-1}} & \dots & \xrightarrow{\pi_2} & \mathbb{R}^1 & \xrightarrow{\pi_1} & \mathbb{R}^0 \end{array}$$

exist having the following properties:

$$(6.9) \quad M^m = M, M^{j-1} = \text{sk } M^j, g_m = g,$$

M^j is a j -dimensional stratified manifold, i_j is a natural embedding. On all the strata of M^j of the higher dimension the following dichotomy holds: either g_j is regular in any point of the stratum, or $\text{rank } dg_j < \dim M^j$ on entire stratum.

Remark. The maps g_j are well defined by map g , the flag (6.7) and the diagram (6.8).

Definition 10.. The contiguity number for the stratified n -dimensional manifold is the maximal number of n -strata adjacent to the $n - 1$ strata in the small neighborhood of the points of these last strata, see Figure 9.

Denote the contiguity number for m_j in (6.8) by ν_j .

Theorem 13. . If the map g_n is nice and (6.8) is the correspondent diagram with the contiguity number ν_j , then the number of inverse images of any regular values g admits the following estimate

$$\#\{g^{-1}(a)\} \leq \frac{1}{2^m} \nu_1 \cdot \dots \cdot \nu_m \cdot \#\{M^0\}$$

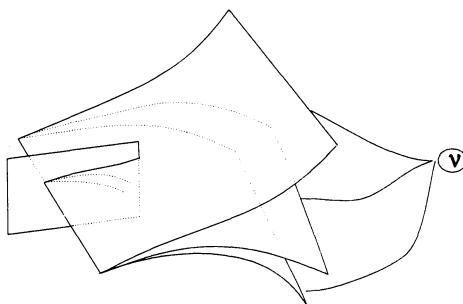

FIGURE 9

◁ The proof goes by induction by j . Suppose the likely estimate for $g_{m-1} : M^{m-1} \rightarrow \mathbb{R}^{m-1}$ is obtained. Eliminate from M^m all the higher strata where the rank of dg drops. This does not change the number of regular preimages and the map g with the domain narrowed in this way still remains to be nice. Take a regular value b of g_{m-1} and consider a function

$$\varphi(a) = \#g^{-1}(a) \text{ for } a \in \mathbb{R}^1 = \pi_m^{-1}b.$$

This function is piecewise constant and jumps in the points of the image of the visible contour of M^m only. The magnitude of each jump is, roughly speaking, no larger than ν_m , and the number of jumps is no larger than

$$J = \frac{1}{2^{m-1}} \nu_1 \cdot \dots \cdot \nu_{m-1} \cdot \#\{M^0\}$$

by the induction assumption, see Figure 10. For the values of a close to $-\infty$ and ∞ , $\varphi(a) = 0$. Therefore its maximal value is no greater than one half of its oscillation, which may be in turn estimated;

$$\text{osc } \varphi \leq J \cdot \nu_m.$$

This proves the theorem. ▷

The theorem shows that the nice map has the Gabrielov property. Now we have to prove that the map

$$(6.10) \quad g : (y, \varepsilon) \mapsto (\mathcal{F}(j_C^n f, \varepsilon), \varepsilon) \in \mathbb{R}^{n+k}$$

with the generic $f \in C$ is nice.

6.5. Step IV. Thom–Boardmann like classes..

We replace the family of equations (6.5), (6.6) by a single equation

$$g = (a, \varepsilon)$$

g is the map (6.10), because we want to have a uniform estimate of the number of regular inverse images with respect to ε . In order to investigate the map g , introduce some notations used for the nice maps.

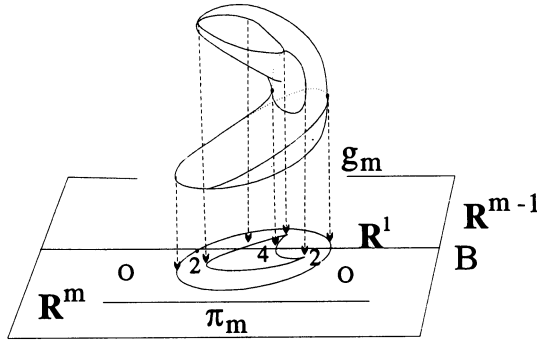

FIGURE 10

Definition 11. . The criminant set K_g of the map $g : M^m \rightarrow \mathbb{R}^m$ of the stratified manifold is the union of $sk M^n$ and the set of critical points of g on the n -strata of $M : \Sigma = \{x \in \text{higher strata} \mid \text{rank } dg < n\}$

We say that the map g agrees with the stratification \mathcal{M} of M^n , or \mathcal{M} stratifies g , if the following dichotomy holds: each n -stratum $M_\alpha \in \mathcal{M}$ entirely consist either or regular, or of critical points of g . The skeleton of the stratification which stratifies g will be called the essential criminant set of g (it is defined up to a choice of stratification which agrees with g).

Remark. The sufficient condition for the map g to be nice is the existence of the commutative diagram (6.8) with the properties (6.9) and the following one:

each M^{j-1} is the essential criminant set for the map $g_j : M^j \rightarrow \mathbb{R}^j$.

Fix a polynomial map \mathcal{F} in (6.10) and a flag (6.7).

Theorem 14. . There exist algebraic sets K_l in the jet space J_C^{n+l} such that:
 codim $K_l = l$;

the set K_l is the “universal criminant set” in the following sense:

if the $n + l$ -jet extension of $f \in C$ is transversal to K_l for any l , then the map g (6.10) is nice.

The constructions goes by induction with respect to $l = m - \dim M^j$ in (6.8). It is like the classical one, due to Thom- Boardmann.

Let $M^m \subset \mathbb{R}^{n+k}$, $m = n+k$ be the ball in the space of y, ε , phase variables

and parameters in (6.6). Let $f \in C$ be a Cartesian map (6.6)

$$M^m \rightarrow \mathbb{R}^n$$

Consider the first universal criminant set

$$\mathcal{K}_1 \subset J_C^{n+1}$$

$$\mathcal{K}_1 = \{j_C^{n+1} f \mid \text{rank } dg_x > m, \bar{x} \in \text{int } B\} \cup \{j_C^{n+1} f \mid \bar{x} \in \partial B\}$$

where \bar{x} is the source of the jet $j_C^{n+1} f$, g is the map(6.10).

The set \mathcal{K}_1 is obviously an algebraic variety in J_C^{n+1} .

The following construction makes use of two important remarks.

1. Consider a map

$$\mathbb{R}^r \oplus \mathbb{R}^t \rightarrow \mathbb{R}^{r+t},$$

$$x \mapsto (g_1, \dots, g_r, h_1, \dots, h_t)(x)$$

and suppose that $g = (g_1, \dots, g_r)$, $h = (h_1, \dots, h_t)$ and $\text{rank } dg|_{g=0} = r$.

Then the set of critical points of the restriction of h onto the set $g = 0$ is given by the equations

$$g = 0, dg_1 \wedge \dots \wedge dg_r \wedge dh_1 \wedge \dots \wedge dh_s = 0$$

This fact lies in the foundation of the classical Thom–Boardmann construction.

2. Consider a semialgebraic set \mathcal{K} in the jet space J_C^L for some L given by the polynomial system

$$G = 0, G = (G_1, \dots, G_r)$$

with the additional requirement $\text{rank } dg|_{\mathcal{K}} = r$.

Suppose that the L -jet extension of a map $f \in C$ is transversal to \mathcal{K} . Then the map

$$g = G \cdot j^L f$$

has rank r on the set $\{g = 0\}$.

These remarks allow to proceed the construction of the universal criminant sets \mathcal{K}_l , using the following theorem of Whitney.

Theorem. . For any algebraic variety $\overline{\mathcal{K}}$ in the affine space there is a semi-algebraic set \mathcal{K} , which is in fact a manifold such that:

1. For any point $x \in \mathcal{K}$ a system G of polynomials exist such that in some neighborhood U of x

$$\begin{aligned}\mathcal{K} \cap U &= \{G = 0\} \cap U; \\ \text{rank } dG &= \text{codim } \mathcal{K}\end{aligned}$$

on $\mathcal{K} \cap U$;

2. $\dim(\overline{\mathcal{K}} \setminus \mathcal{K}) < \dim \mathcal{K}$.

This concludes the proof of Theorem 14.

6.6 Cartesian transversality theorem..

To conclude the proof of Theorem 10 we need a Cartesian analogue of the classical Thom's transversality theorem.

Theorem 15. . Let C , as before, be a space of maps of the form (6.6), and let \mathcal{K} be an algebraic variety in the space J_C^L . Then a generic map $f \in C$ has L -jet extension which is transversal to all the strata of \mathcal{K} .

This theorem is proved by Shelkovernikov. The proof is analogous to that of the classical transversality theorem.

This concludes the proof of the Theorem 10.

REFERENCES

- [A] V. I. Arnold, *Supplementary chapters of the theory of the differential equations*, Nauka, Moscow, 1978.
- [AAIS] V. I. Arnold, V. S. Afraimovich, Yu. S. Ilyashenko, L. P. Shilnikov, *Bifurcation theory*, Dynamical system V, VINITI, Moscow, 1986.
- [B] G. R. Belitski, *Equivalence and normal forms of germs of smooth maps*, Russian Math. Surveys **1** (1978), 91–155.
- [Bo] R. I. Bogdanov, *Local orbital normal forms of vector fields in the plane*, Proceeding of the Seminar of I. G. Petrovskii **5** (1986), Moscow, 51–84.
- [Br] A. D. Bruno, *Local method of nonlinear analysis of differential equations*, Nauka, Moscow, 1979.
- [G] A. M. Gabrielov, *Projections of semianalytic sets*. *Funct. Anal. and appl.* **2** (1978), no. 4.
- [I] Yu. S. Ilyashenko (ed.), *Around Hilbert 16th problem*, Collection of papers by Yu. S. Ilyashenko, O. A. Kleban, A. Yu. Kotova, S. I. Trifonov, S. Yu. Yakovenko (to appear).
- [IY1] Yu. S. Ilyashenko, S. Yu. Yakovenko. *Smooth normal forms of local families of diffeomorphisms and vector fields*. *Russian Math. Surveys* **46** (1991), no. 1, 3–39.

- [IY2] Yu. S. Ilyashenko, S. Yu. Yakovenko, *Stokes phenomena in smooth classification problem*, Nonlinear Stokes phenomena (Yu. S. Ilyashenko, ed.), AMS (to appear).
- [IY3] Yu. S. Ilyashenko, S. Yu. Yakovenko, *Hilbert-Arnold problem for elementary polycycles*, Around Hilbert 16th problem (to appear).
- [Kh] A. G. Khovanskii, *Funomials*, AMS, Providence RI, 1991.
- [K] V. P. Kostov, *Versal deformations of differential forms of degree α on the line*, *Funct. Anal. and appl.* **18** (1984), 81–82.
- [KS] A. Yu. Kotova, V. Stanzo, *Bifurcations on planar polycycles in generic two and three parameter families: systematizations and some new effects*, to appear.
- [M] J. N. Mather, *Stratifications and mapping*. *Dynamic Systems* (Pieixoto, eds.), Acad. Press, NY and London, 1973, pp. 195–232.
- [R] R. Roussarie, *On the number of limit cycles which appear by perturbation of separatrix loop of planar vector fields*, *Bol. Soc. Math. Brasil* **17** (1986), 67–101.
- [S] V. S. Samovol, *Equivalence system of differential equations in the neighborhood of a singular point*, *Proceedings of Moscow Math. Society* **44** (1982), 213–234.
- [T] F. Takens, *Partially hyperbolic fixed points*, *Topology* **10** (1971), 133–147.
- [W] H. Whitney, *Local properties of analytic varieties*. *Differential and Combinatorial Topology*, Princeton, 1965.

Yu S. Ilyashenko
Moscow State University
Department of Mathematics
Moscow – USSR
117234