

# *Astérisque*

I. TAMANINI

## **On the sphericity of liquid droplets**

*Astérisque*, tome 118 (1984), p. 235-241

[http://www.numdam.org/item?id=AST\\_1984\\_\\_118\\_235\\_0](http://www.numdam.org/item?id=AST_1984__118_235_0)

© Société mathématique de France, 1984, tous droits réservés.

L'accès aux archives de la collection « Astérisque » (<http://smf4.emath.fr/Publications/Asterisque/>) implique l'accord avec les conditions générales d'utilisation (<http://www.numdam.org/conditions>). Toute utilisation commerciale ou impression systématique est constitutive d'une infraction pénale. Toute copie ou impression de ce fichier doit contenir la présente mention de copyright.

NUMDAM

Article numérisé dans le cadre du programme  
Numérisation de documents anciens mathématiques

<http://www.numdam.org/>

ON THE SPHERICITY OF LIQUID DROPLETS

by I. TAMANINI (Università Trento)

Several results concerning the shape of liquid drops, sitting on a table and making a constant contact angle with it, have recently been obtained by R. Finn - see the bibliography in [2]. In [2] in particular, a rigorous proof is provided for the (on physical grounds) intuitive fact, that the free surface of a droplet is asymptotically spherical as the volume tends to zero.

Finn's proof uses the symmetry of the equilibrium configurations in a substantial way. Indeed, once that property is assumed (or perhaps *proved*, see Section 1 below) one readily observes that the profile of the drop is described by a solution curve of the differential equation

$$(r \sin \psi_u)_r = k r u \quad (\psi_u = \arctan u')$$

with the appropriate boundary conditions.

By estimating the characteristic parameters of the solution in terms of the enclosed volume, one is eventually led to the convergence of the meridional curvature of the solution curve to a (relative to drop's size) constant value, in a certain uniform way which is discussed in [2]. This obviously implies the convergence of the drops to the spherical shape, as the volume tends to zero.

What we want to point out with the present note is that a similar result can be obtained, even without the need of assuming the symmetry of the solutions: this enables us to consider liquid drops sitting on curved surfaces, and making a continuous (not necessarily constant) contact angle with the supporting surfaces.

The method we use is based on abstract convergence results of almost minimal

boundaries, in a form which appears e.g. in [6]. Roughly speaking, we consider a sequence of drops with decreasing volume, all sitting on a given smooth hyper-surface. By means of an obvious transformation, a new sequence of similar solutions is produced, all with the same volume, now sitting however on different surfaces, which become flatter and flatter under the transformation. In the limit, the new solutions are shown to approach a spherical cap, with convergence of both the free surfaces and their normals. Details will appear in a subsequent paper.

In the following, with the purpose of giving the basic ideas of the method, while keeping the technical part of the argument at a minimum, we will restrict ourselves to the simple case considered by Finn (i.e., drops on a plane surface, with gravity and constant contact angle): we proceed however as if we were considering the more general case, pointing out from time to time the precise role played (in this context) by the symmetry of the solutions.

1. Let's consider first of all the "homogeneous case", when a drop of given volume  $v$  is at rest on the hyperplane  $S = \{x_n = 0\} \subset \mathbb{R}^n$ , in the absence of gravity and with a constant contact angle  $\gamma$ . As we shall see below, this is in a sense the limit case of a more general situation.

The energy of such a simple system can be written in the following form:

$$(*) \quad \mathcal{F}_\alpha(E) \equiv \text{area } \Gamma_E + \alpha \cdot \text{area } \Sigma_E$$

where  $E$  denotes the region in  $S^+ = \{x_n > 0\}$  occupied by the liquid,  $\Gamma_E$  its free surface,  $\Sigma_E$  the contact surface, and  $\alpha \in \mathbb{R}$  (see Figure 1).

It is well known that the two areas in (\*) can be given a precise meaning in the framework of the Theory of Perimeters, see e.g. [5].

The (unique, up to translations) minimum of (\*) in the class  $\mathcal{E}_v$  of admissible configurations:

$$\mathcal{E}_v = \{E \subset S^+ : \text{area } \Gamma_E < +\infty, \text{meas } E = v\}$$

SPHERICITY OF LIQUID DROPLETS

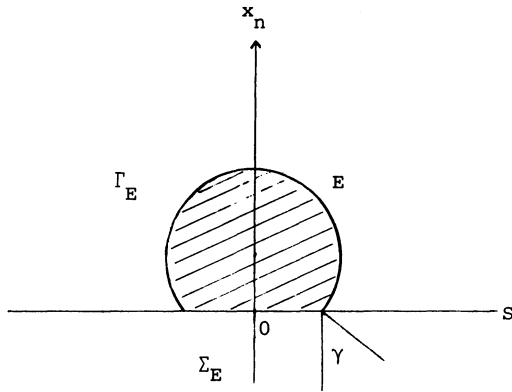

Figure 1

is, of course, a "spherical drop", that is, the intersection of a suitable  $n$ -ball with  $S^+$ .

Let's spend some words on the proof of this "elementary" fact. Firstable, we observe that the really interesting case occurs when  $\alpha \in (-1, 1)$ , since the solution is obviously an  $n$ -ball when  $\alpha \geq 1$ , while no solution can exist when  $\alpha \leq -1$ . Secondly, given  $F \in E_v$ , we use Schwarz symmetrization (see [3] and Figure 2) to construct a new element  $F^*$  of  $E_v$ , with lower energy:

$$F_\alpha(F^*) \leq F_\alpha(F) .$$

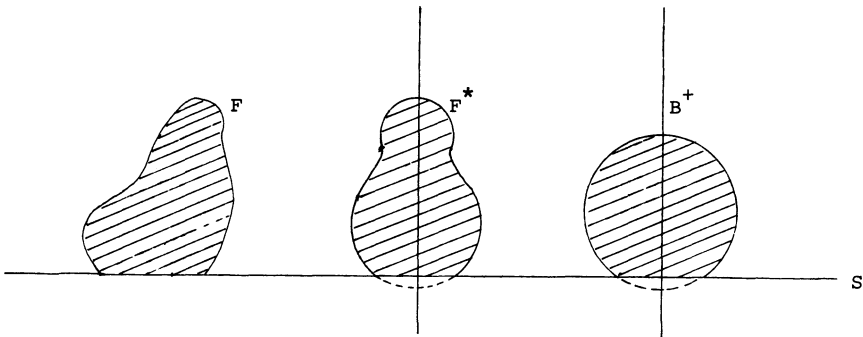

Figure 2

Next, by considering (see Figure 2 again)  $B^+ = B \cap S^+$ ,  $B$  an  $n$ -ball satisfying:  $\text{meas } B^+ = v$ ,  $\text{area } \Sigma_{B^+} = \text{area } \Sigma_{F^*} = \text{area } \Sigma_F$ , we get

$$\mathcal{F}_\alpha(B^+) \leq \mathcal{F}_\alpha(F^*) ,$$

in view of the isoperimetric property of  $B$ . Finally, letting  $\gamma \in [0, \pi)$  denote the contact angle of  $B^+$ , and putting

$$s_n(\gamma) = \int_0^{\pi-\gamma} \sin^n t dt ,$$

we find

$$\mathcal{F}_\alpha(B^+) = \omega_{n-1}^{1/n} \cdot v^{(n-1)/n} \cdot \left\{ n(s_n(\gamma))^{1/n} + (\alpha - \cos\gamma) \cdot \sin^{n-1}\gamma \cdot (s_n(\gamma))^{(1-n)/n} \right\} .$$

The last expression is minimized exactly when  $\gamma = \arccos \alpha$ , thus proving that the spherical drops with the right contact angle are the configurations of least energy.

2. Now consider a sequence  $v_j \downarrow 0$ , and a corresponding sequence of drops of volume  $v_j$  in a gravity field, i.e. a sequence  $\{E_j\}$  of minimizers for the energy functional:

$$(**) \quad \mathcal{F}_{\alpha, \beta}(E) \equiv \text{area } \Gamma_E + \alpha \cdot \text{area } \Sigma_E + \beta \cdot \int_E x_n dx$$

(with  $\alpha \in (-1, 1]$  and  $\beta > 0$ ), in the class  $\mathcal{E}_{v_j}$ .

The last integral in (\*\*) corresponds to the gravitational energy. Without loss of generality, we may and shall assume that the centre of mass of the drops be located on the  $x_n$ -axis. Performing a similarity transformation, we get a new sequence  $\{G_j\}$  of minimizers of  $\mathcal{F}_{\alpha, \beta_j}$  in  $\mathcal{E}_v$ , for some fixed  $v > 0$  and with  $\beta_j = (v_j/v)^{2/n} \downarrow 0$ .

An elementary calculation shows that

$$\text{area } \Gamma_{G_j} \leq \text{const. (independent of } j)$$

and then clearly the area of each horizontal section of  $G_j$  is bounded from above, uniformly in  $j$ . As a consequence of the axial symmetry of the solutions (which follows again from Schwarz symmetrization), and of the assumption on their centre of mass, an uniform bound on the maximal radial extension of the  $G_j$ 's is readily derived; the corresponding bound in the vertical direction being easy to obtain, we find in conclusion that each  $G_j$  is contained in a fixed compact set in  $\mathbb{R}^n$ . The  $L^1$ -convergence of (a subsequence of)  $\{G_j\}$  toward a certain element  $G_\infty$  of  $E_V$  is then assured by known compactness results.

3. We now proceed to show that (i)  $G_\infty$  is a spherical cap, and (ii) the convergence  $G_j \rightarrow G_\infty$  is a "good convergence". To do so, we begin by establishing the following semicontinuity result:

$$(\dagger) \quad \mathcal{F}_\alpha(G_\infty) = \mathcal{F}_{\alpha,0}(G_\infty) \leq \liminf_{j \rightarrow +\infty} \mathcal{F}_{\alpha,\beta_j}(G_j) .$$

The derivation of  $(\dagger)$  is almost immediate; see e.g. [5], Proposition 1. We deduce from  $(\dagger)$  that  $G_\infty$  is a minimizer of  $\mathcal{F}_\alpha$  in  $E_V$ , thus proving (i) above, in view of the preceding discussion.

Next we prove that  $\{\Gamma_{G_j}\}$  is a sequence of uniformly almost minimal boundaries in  $S^+$ , in the sense that:

$$(\dagger\dagger) \quad \text{area}(\Gamma_{G_j} \cap B_r) \leq \text{area}(\Gamma_G \cap B_r) + \text{const. } r^n$$

for every  $j$ , every ball  $B_r$  of sufficiently small radius  $r$  compactly contained in  $S^+$ , and every variation  $G$  of  $G_j$  in  $B_r$  (with a constant independent of  $j$ ). This basic relation can be derived in a standard way, arguing as in [4], see also [1].

Once  $(\dagger\dagger)$  is established, we may appeal to a general result on the convergence of almost minimal boundaries, see in particular Theorem 1 of [6], to conclude that the whole sequence  $\{G_j\}$  converges toward the spherical drop  $G_\infty$ , with uniform convergence (on compact subsets of  $S^+$ ) of the free surfaces  $\Gamma_{G_j}$  and of their

normals. This is to be intended in the following sense: for every  $\varepsilon > 0$  an index  $j_\varepsilon$  can be found, such that  $\Gamma_{G_j} \cap S_\varepsilon \subset A_\varepsilon \cap S_\varepsilon$  for every  $j > j_\varepsilon$ , where  $S_\varepsilon = \{x_n > \varepsilon\}$  and  $A_\varepsilon = \varepsilon$ -neighbourhood of  $\Gamma_{G_\infty}$ . Additionally, a radius  $r_\varepsilon$  can be found, such that  $|\nu_j(z) - \nu_\infty(x)| < \varepsilon$  for every  $j$  as above, every  $x \in \Gamma_{G_\infty}$  and every  $z \in \Gamma_{G_j} \cap B(x, r_\varepsilon)$ , where  $\nu_j(z)$  and  $\nu_\infty(x)$  denote the outward unit normals to  $\Gamma_{G_j}$  and  $\Gamma_{G_\infty}$ , at points  $z$  and  $x$  respectively.

4. We remark that the convergence of the drops to the spherical shape, in the sense explained above, holds for every  $\alpha \in (-1, 1]$ , or equivalently for every contact angle  $\gamma = \arccos \alpha \in [0, \pi)$ . Using the symmetry of the solutions, one can easily show that the convergence  $\Gamma_{G_j} \rightarrow \Gamma_{G_\infty}$  is uniform on the entire half-space  $\{x_n \geq 0\}$ ; see e.g. [5], Section 4 (particularly Theorem 4.5).

It is worth noticing however, that a nonuniformity appears in the rate of contraction of  $\Sigma_{G_j}$  toward  $\Sigma_{G_\infty}$ , depending on whether  $\alpha < 1$  or  $\alpha = 1$ ; see [2], Theorem 4.5.

REFERENCES

- [1] E. BAROZZI, E.H.A. GONZALEZ, Least area problems with a volume constraint, these proceedings.
- [2] R. FINN, Global size and shape estimates for symmetric sessile drops, *J. Reine Angew. Math.* 335 (1982), 9-36.
- [3] E.H.A. GONZALEZ, Sul problema della goccia appoggiata, *Rend. Sem. Mat. Univ. Padova* 55 (1976), 289-302.
- [4] E.H.A. GONZALEZ, U. MASSARI, I. TAMININI, On the regularity of boundaries of sets minimizing perimeter with a volume constraint, *Indiana Univ. Math. J.* 32 (1983), 25-37.
- [5] \_\_\_\_\_, Existence and regularity for the problem of a pendent liquid drop, *Pacific J. Math.* 88 (1980), 399-420.

*SPHERICITY OF LIQUID DROPLETS*

- [6] I. TAMANINI, Boundaries of Caccioppoli sets with Hölder-continuous normal vector, *J. Reine Angew. Math.* 334 (1982), 27-39.

Italo TAMANINI  
Dipartimento di Matematica  
Università di Trento  
I-38050 Povo (TN)  
Italy