

Source Control Options for Reducing Emission of Priority Pollutants from Urban Areas

Peter Steen Mikkelsen^{1*}, Hans-Christian Holten Lützhøft¹, Eva Eriksson¹, Anna Ledin¹, Erica Donner², Lian Scholes², Mike Revitt², André Lecloux³, Tonie Wickman⁴, Nataša Atanasova⁵, Boris Kompare⁵ and Primož Banovec⁵

¹ DTU Environment, Department of Environmental Engineering, Technical University of Denmark, Miljøvej, Building 113, DK-2800 Kgs. Lyngby

² Urban Pollution Research Centre, Middlesex University, Queensway, Enfield, Middlesex, EN3 4SA, UK

³ Envicat Consulting, Avenue Montesquieu 36, B-1300 Wavre, Belgium

⁴ Environmental Monitoring, Stockholm Stad, Box 8136, Tekniska nämndhuset, Fleminggatan 4, S-104 20 Stockholm, Sweden

⁵ University of Ljubljana – Faculty of Civil and Geodetical Engineering, Jamova 2, SI-1000 Ljubljana

*Corresponding author, e-mail psm@env.dtu.dk

ABSTRACT

The overall aim of the ScorePP project is to develop comprehensive and appropriate source control strategies that authorities, cities, water utilities and the chemical industry can employ to reduce emissions of priority pollutants (PPs) from urban areas into the receiving water environment. Focus is on the 33 priority and priority hazardous substances and substance groups identified in the European Water Framework Directive. However, this list may be expanded to include emerging pollutants or reduced if appropriate model compounds can be identified. The initial work focuses on 67 substances, including substances identified in the proposed European environmental quality standard (EQS) directive as well as the defined example compounds and several organometallic derivatives. Information on inherent properties, environmental presence and fate, and legislative issues is made available in open database format, and a data management system combining chemical identification (CAS#), NACE economic activity classifications and NOSE-P emission source classifications has been developed as a basis for spatial characterisation of PP sources using GIS. Further work will focus on dynamic urban scale source-flux models, identifying emission patterns and optimising monitoring programmes in case studies and multi-criteria comparison of source control versus end-of-pipe mitigation options in relation to their economic, social and environmental impacts.

KEYWORDS

Diffuse pollution; emission control; priority pollutants; urban environment; source characterisation

INTRODUCTION

The European Commission (EC) has, in connection with the Water Framework Directive (WFD), identified a list of 33 priority substances (PSs) for which environmental quality standards and emission control measures have to be established (EC, 2001). The list was developed through a negotiation process and involved the use of scientific data on a range of properties of each substance including pollutant load, toxicity, persistence and liability to accumulate in the environment. Within this list a total of 11 substances have been identified as being particularly hazardous, and these priority hazardous substances (PHs) are subject to a

complete cessation or phasing-out of discharges, emissions or losses within an appropriate time scale not exceeding 20 years. The overall list is under constant review and it is anticipated that certain of the ‘possibly hazardous’ substances will be “upgraded” to a PHS status and that several emerging pollutants will also be added to the list at a future date. As a first example, the EC has recently proposed a set of environmental quality standards (EQS) (EC, 2006), which in addition to the 33 PSs identified in the WFD includes 8 extra compounds and “upgrades” one chemical, anthracene, from PS to PHS status (i.e. there are now 41/12 PSs/PHSs to consider).

The complete cessation or significant reduction of PS/PHS emissions is a big challenge for the European Union (EU), and there are numerous scientific and practical questions remaining. For example: is it more feasible to control the substances via enhancing end-of-pipe treatment technologies or to control them at source via a combination of substitution, voluntary use reductions and/or legislation? The aim of this paper is to introduce a European research project designed to shed light on this issue within an urban context, and to present the first results about source characterisation of priority pollutants.

THE SCOREPP IDEA

The ScorePP project (Source Control Options for Reducing Emissions of Priority Pollutants) is a recently started European ‘Specific Targeted Research Project’ that aims to develop comprehensive and appropriate source control strategies that authorities, cities, water utilities and the chemical industry can employ to reduce emissions of priority pollutants (PPs) from urban areas into the receiving water environment. PPs in this context refer specifically to the above mentioned PSs/PHSs; this list may however be expanded to include emerging pollutants or reduced if appropriate model compounds can be identified, depending on the local context (i.e. sources of pollution, existing monitoring activities and legislation).

Limiting release through:

- Substitution
- Minimising release from products
- Legislation and regulations
- Voluntary use reductions

Treatment options:

- Stormwater BMPs
- Household treatment & reuse of WW
- On-site industrial treatment
- WWTPs
- Sludge disposal

Sinks:

- Primary: Surface water (WFD)
- Secondary: Sediments, soils/gr.water, humans, ...

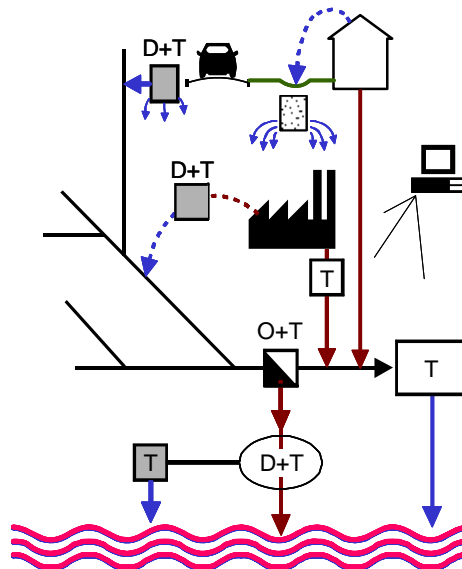

Fig. 1. Representation of the physical system considered in the ScorePP project, exemplified with a combined sewer system including both upstream (source control) and downstream (end-of-pipe treatment) mitigation options. In addition to the shown point discharges (treatment plants and combined sewer overflows) there are diffuse discharges from e.g. building drains and unknown pipe networks and overland flow. D: Detention, O: Overflow, T: Treatment.

A substantial proportion of the total load of PPs entering receiving waters is discharged from urban areas and this is therefore the primary focus of the ScorePP project (see also Figure 1). Agricultural, industrial and other potential sources (e.g. leachate from landfill sites) located outside urban areas will only be included if specifically required within the case studies investigated in the project. This does not imply that the project consortium considers urban pollution more important than rural; it merely reflects the focus of the project around which expertise is gathered and the work plan has been developed.

MAIN SCIENTIFIC OBJECTIVES

As illustrated in Figure 2, the project is divided into a number of work packages (WPs) that specifically address a range of identified objectives and follow in a logical sequence. The primary scientific objectives of the ScorePP project are, in brief, to identify the sources of PPs in urban areas (WP3), identify appropriate strategies for limiting the release of PPs from their sources (WP4) and for their removal via treatment (WP5), connect and visualise pollution sources, paths and loads using GIS technology (WP6), develop dynamic source-and-flux models for quantifying the fate of PPs within the urban drainage and wastewater system and optimising monitoring programmes (WP7), and benchmark the different emission control strategies and determine their socio-economic impacts on a societal scale (WP8).

It is appreciated that some of the emission control measures may be potentially controversial as they depend on the full participation of the chemical industry, water utilities and/or other stakeholders involved in urban spatial planning, with potential economic and social (as well as environmental) impacts and implications. Three further scientific objectives are therefore defined as follows: evaluate the usefulness of the developed approaches, technologies and emission control strategies in a number of case study cities (WP2), interact with the most important stakeholders and communicate the results of the project to a wide audience (WP1) and finally, integrate and condense the developed knowledge and experiences into appropriate and cost-efficient emission control strategies for semi-hypothetical case city archetypes representing PP emission states in different geographic and socio-economic contexts throughout Europe (WP9).

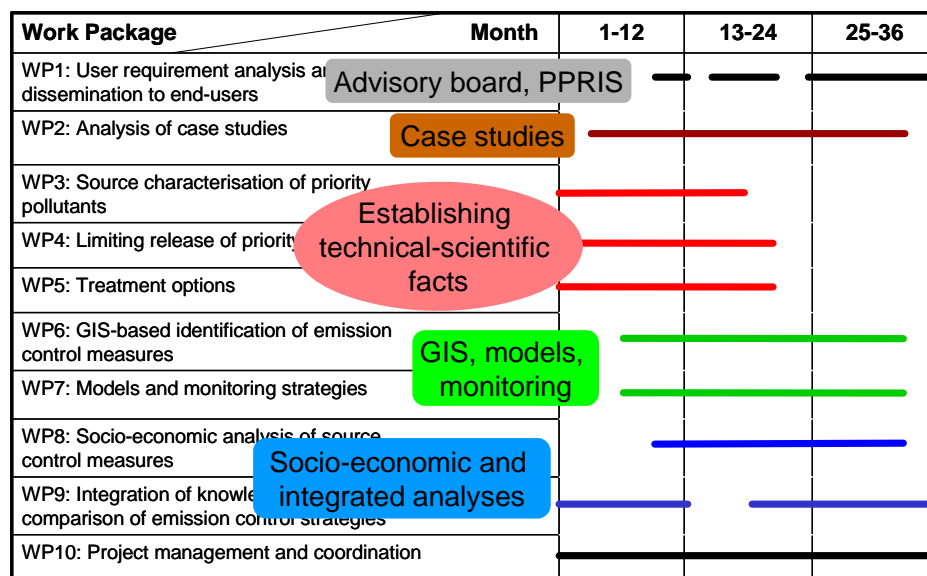

Fig. 2. Overall work plan for the ScorePP project illustrating the 10 work packages, their temporal evolution and (in enlarged text bubbles) their grouping according to the nature of the work.

Table 1. ScorePP priority pollutants (PPs) grouped according to their main uses and classified according to whether they are priority substances (PSs), added due to the EQS-proposal (EQS), example chemicals (EX) or added as they belong to the group “organometallics” (OM). Priority hazardous substance (PHSs) are printed in **bold**^b.

Class ^a	Biocide (31)	Chlorinated solvent (6)	Combustion (7)	Flame retardant (2)	Fuel additive (5)	Intermediate (11)	Plasticizer (1)	Various ^e (4)
PS (33)	Trifluralin	Ethylene chloride	Hexachlorobenzene	Pentabromobiphenylether		Naphthalene	DEHP	Nickel ^f
	Hexachlorocyclohexane	Dichloromethane	PAH	C₁₀₋₁₃ chloroalkanes		Anthracene		Mercury^f
	Alachlor	Chloroform				Nonylphenol		Lead ^f
	Pentachlorophenol					Fluoranthene		Cadmium^f
	Endosulfan					Benzene		
	Simazine					Trichlorobenzenes		
	Atrazine					Octylphenol		
	Chlorfenvinphos					Pentachlorobenzene		
	Isoproturon							
	Diuron							
	Chlorpyrifos							
	Hexachlorobutadiene							
	Tributyltin compounds							
EQS (11)	Aldrin	Trichloroethylene						
	Endrin	Tetrachloroethylene						
	Isodrin	Carbontetrachlorid						
	Dieldrin							
	Para,para'-DDT							
	Para,para'-DDE ^c							
	Para,para'-DDD ^c							
	Orto,para'-DDT ^d							
EX (11)	Tributyltin-cation		Indeno(1,2,3-cd)pyrene			4-(para)nonylphenol		
	Alpha-endosulfan		Benzo(k)fluoranthene			Para-tert-octylphenol		
	Gamma-isomer lindane		Benzo(g,h,i)perylene					
	1,2,4-trichlorobenzene		Benzo(a)pyrene					
			Benzo(b)fluoranthene					
OM (12)	Tetra-N-Butyltin				Tetramethyl lead	Dimethylmercury		
	Bis(tributyltin) oxide				Ethyltrimethyl lead			
	Phenylmercuric acetate				Tetraethyl lead			
	Tributyltin methacrylate				Methyltriethyl lead			
	Tributyltinchlorostannane				Diethyldimethyl lead			
	Methylmercury							

^a: Classified according to the WFD and the EQS-proposal. The numbers in brackets represent the number of chemicals in each class; ^b: Originally there were 11 PHSs among the 33 PSs, of which one was PAH (a summary parameter), but as five individual chemicals represent the PAH-group and because anthracene has been proposed to be a PHS, there are now 17 PHSs all together; ^c: This is a degradation product of para,para'-DDT; ^d: This is an impurity of para,para'-DDT; ^e: In this respect, various covers a range of uses like alloys, catalysts, pigments, batteries, dentistry, measuring and control equipment, biocide, impurity, cables, stabilisers, intermediate; ^f: The individual metals represents the ionic form(s).

The WPs are connected group-wise according to the nature of the work, as shown by the text bubbles in Figure 2. Case cities selected for detailed case study include Stockholm (Sweden), St. Malo (France), Prague (Czech Republic), Quebec (Canada) and St. Sebastian (Spain). The advantage of these 5 pre-selected case studies is that they represent a wide range of “states” with regard to monitoring and source control of priority pollutants. The project started in late 2006 and is thus presently at an early stage (month 8). Some of the main achievements during the first half year are outlined below, with an emphasis on describing the environmental behaviour of the PPs and classifying their sources.

THE WFD PRIORITY SUBSTANCES AND PRIORITY HAZARDOUS SUBSTANCES

The aims of the initial tasks in WPs 3 and 4 have been to identify the chemicals listed in the WFD and in the EQS-proposal (EC, 2001, 2006), to compile basic information about them and to identify their (main) uses, as illustrated in Table 1. The reason for the term “identify the chemicals” is that the WFD only lists 33 PSs. However, some of these are actually groups of substances, and in such cases examples of specific chemicals within these groups are given (EX, 11 in total). Furthermore, the metals are listed as “metal and its compounds”, rendering the possibility to include not only the metal in its ionic form(s), but also some of its organometallic derivatives (OM, 12 in total). The EQS-proposal finally lists another 8 chemicals and some specific examples (11 in total). For the purpose of the ScorePP project, a list of 67 PPs has been established (Table 1).

The selected substances can be categorised in many ways. They may for example be described in terms of their chemical class such as aromatics, polyaromatic hydrocarbons, phenolics, phthalates, triazines, halogenated hydrocarbons, organometallics and metals. These diverse substances have very different chemical structures, physico-chemical characteristics and properties, as well as a diversity of use and disposal patterns within different sectors of society. Certain PSs are also derived unintentionally, as unavoidable by-products for example, in combustion or industrial chemical processes. PHSs and PSs in general have multiple sources varying from the localised (e.g. household) scale through industrial application to traffic derived sources and hence, the targeting of PSs using source control measures is a significant and complex challenge. About 600 use categories have been identified for the 67 chemicals listed in Table 1 and thus, we have grouped the chemicals according to their *main use* here, as this gives a generic overview of where they originate from.

Table 2. Inherent properties, environmental fate and presence and legislative issues compiled for the range of chemicals identified in Table 1. Chemical Abstract Services (CAS) numbers are used as main identifiers for the PPs but not shown in Table 1 due to space limitations.

Inherent properties	Environmental		Legislative issues
	Fate	presence	
CAS #, EINECS, Merck #	Organic carbon and water distribution	Surface waters	EU legislation
Molecular formula	Solids and water distribution	Porewater	Selected national legislation
Density	Complex formation	Suspended sediment	Risk and safety phrases
Molecular weight	Photodegradation	Sediment	Classification
Melting point	Oxidation	Soil	Symbols
Boiling point	Hydrolysis		Peak concentration limits
Aqueous solubility	Biodegradation		Average concentration limits
1-octanol and water distribution			Restricted use
Vapour pressure			Ban
Acid dissociation constant			
Henry's law constant			

In order to evaluate the chemicals and their applications and to further model their releases and emissions into the environment, information about their inherent properties, environmental fate and presence and legislation (see Table 2) have been compiled from a range of authoritative sources (Syracuse Research Corporation, 1999; Tomlin, 2005; The Merck Index, 2006; US National Library of Medicine, 2006; European Chemicals Bureau, 2007) and stored in open database format (Holten Lützhøft et al., 2007). The database offers the opportunity to extract all the above mentioned information about a single chemical or to compare one parameter for two or more chemicals. Where appropriate information was available, the parameters have been described with respect to the existing specific experimental circumstances (temperature, pH-value, type of sediment, etc.). Wherever possible, more than a single value has been reported. This means that, if repetitive experiments have been conducted and reported in the literature, the aim was to report representative values (preferably 3-5) for each specific parameter.

OVERALL STRATEGY FOR DATA MANAGEMENT

In the process of project definition data integration was recognized as an important issue, and the following requirements were subsequently identified:

- The overall data management structure should allow integration of the information gathered in the project about PPs and their sources (as detailed in the previous section), releases and loads, potential mitigation options, emissions into the environment, etc.
- It should allow connection to important data sources describing the production and transport of goods and performance of services in the EU member states;
- It should allow connection to data sources describing the economic and financial aspects of different activities in the EU;
- It should be harmonized with existing pollution emission reporting systems used in the EU.

It quickly became clear that the existing data management structures are based on weak or ad-hoc connectivity of two worlds: (1) the world of pollution monitoring, modelling and reporting and (2) the world of the data collected by national statistical offices and Eurostat. The key EU statistical classification structure for sources of emissions (NOSE-P; CODED, 2007a) and of specific economic activities (NACE; CODED, 2007b) have not yet significantly penetrated the world of pollution modelling and monitoring. Their use is of extreme importance especially in the case of large scale assessments and integration of the data for large topographic areas (Banovec, 2001).

The classification structure used in the US EPA Source Classification Codes (SCC; US EPA, 2004) is of adequate resolution and able to provide the necessary bridging element between different aspects of management of PPs and the processes by which they are produced. However, it can not be used directly for the purposes of the ScorePP project because it is closely linked to the standard statistical classifications used in the USA. Therefore, using inspiration from the SCC, a combined classification structure has been developed by which an emission process (NOSE-P) of a specific substance (CAS) within a specific economic activity (NACE) can be identified in a standardized and harmonized way, thus uniquely identifying a PP source that gives rise to a release and subsequent emission into the environment. These “emission strings” are the central classification structure used for project integration within a

unique database. Several other elements connected with managing PP emissions can also be related to emission strings:

- Models used for quantifying the release from emission sources, e.g. the approach used in the EU Technical Guidance Document for risk assessment of chemicals (European Chemicals Bureau, 2003), or for treatment options at various spatial scales;
- Legal constraints determining which legal acts are relevant to a specific emission string or to all emission strings in which a specific substance is listed;
- Substitution options or voluntary use reductions targeting specific PPs within a specific economic activity or overall;

Integration of other types of data is also possible using the emission string concept. For example, monitoring results that may be assigned to site-specific emission sources can add information about the spatial dimension of the emissions. These possibilities will be further explored later in a later stage of the project.

The database has as a final goal to allow queries addressing the main project question – feasibility of reduction/cessation of PP emissions as planned by the WFD. It is a closed database with protected access, as quality assurance is currently an important on-going activity. Partially open access to the database, or some of its components which are of general interest, will be considered at the final stage of the project.

DISCUSSION

The ScorePP project is still in its initial stage, and several big challenges remain. The data management system described above needs to be connected with the detailed work on mitigation options (those mentioned in WPs4-5) and with models and geographical information systems (GIS) allowing for site-specific source tracing and substance flow analysis as well as optimisation of monitoring programmes. Furthermore, the developed tools need to be applied in case studies and connected with socio-economic evaluations, so that multi-criteria comparison of source control versus end-of-pipe mitigation options in relation to their economic, social and environmental impacts can be made. Finally, fruitful interaction with the European chemical industry and water utility trade associations together with representatives from ministerial, regional, municipal and community organisations needs to be established to ensure that these key urban stakeholders can provide input to framing the scope of the project and in adapting the project outcomes. A particular effort will be made to communicate the results of the project to a wide audience in a sufficiently direct manner that will allow practical use. By the time of the 10th ICUD conference the project will be about half-way, and the conference presentation will report on the latest developments.

CONCLUSIONS

The initial WFD-list of 33 PSs/PHSs has been expanded into a list of 67 PPs, embracing both example chemicals defined in the directive, further chemicals proposed in the EQS directive and selected organometallic derivatives of the listed metals. Information on inherent properties, environmental fate and presence and legislative issues have been collected for these chemicals. As many experimental conditions as possible have been reported along with the particular property, and when reasonable between 3 and 5 values for each property have been collected. An innovative approach to managing data about sources, their resulting PP loads and the available mitigation options has been prepared by combining chemical identification (CAS#), NACE economic activity classifications and NOSE-P emission source classifications. Future challenges are to connect this data management system with the detailed work on mitigation options (those mentioned in WP4-5), with the modelling efforts,

and with the preparation of emission control strategies in the case city studies, as well as to establish a fruitful dialogue with important stakeholders in the area of emission control of PPs.

ACKNOWLEDGEMENT

The presented results have been obtained within the framework of the project ScorePP - "Source Control Options for Reducing Emissions of Priority Pollutants", contract no. 037036, a project coordinated by Institute of Environment & Resources, Technical University of Denmark (DTU) within the Energy, Environment and Sustainable Development section of the European Community's Sixth Framework Programme for Research, Technological Development and Demonstration. The other project participants are Middlesex University (UK), Ghent University (Belgium), Anjou Recherche (France), Envicat Consulting (Belgium), University of Ljubljana (Slovenia), Desenvolupament i Societat Estudis (Spain), City of Stockholm (Sweden) and Université Laval (Canada).

REFERENCES

- Banovec, P. (2001). Connecting the water management data system with the system of standardized classifications (in Slovenian) : doctoral dissertation. University of Ljubljana, 138 pg., 5 app.
- CODED (2007a). Eurostat Concepts and Definitions Database: Nomenclature for Sources of Emissions. <http://circa.europa.eu/irc/dsis/bmethods/info/data/new/coded/en/gl001372.htm> (accessed 15 July 2007).
- CODED (2007b). Eurostat Concepts and Definitions Database: NACE rev 1 (Statistical classification of economic activities in the European Community). <http://circa.europa.eu/irc/dsis/bmethods/info/data/new/coded/en/gl000002.htm> (accessed 15 July 2007).
- European Chemicals Bureau (2003). Technical Guidance Document on Risk Assessment in support of Commission Directive 93/67/EEC on Risk Assessment of new notified substances and Commission Regulation No 1488/94 on Risk Assessment of existing substances and Directive 98/8/EC of the European Parliament and of the Council concerning the placing of biocidal products on the market. Part II.
- European Chemicals Bureau (2007). ORATS: Online European Risk Assessment Tracking System.. <http://ecb.jrc.it/esis/index.php?PGM=ora> (accessed 15 July 2007).
- European Commission (2001). Decision No 2455/2001/EC of the European Parliament and of the Council of 20 November 2001 establishing the list of priority substances in the field of water policy and amending Directive 2000/60/EC. Official J. of the Europ. Communities, 15.12.2001. http://europa.eu.int/eur-lex/pri/en/oj/dat/2001/l_331/l_33120011215en00010005.pdf (accessed 15 July 2007).
- European Commission (2006). Proposal for a Directive of the European Parliament and of the Council on environmental quality standards in the field of water policy and amending Directive 2000/60/EC. Brussels, 17.7.2006. http://ec.europa.eu/environment/water/water-dangersub/pdf/com_2006_397_en.pdf (accessed 15 July 2007).
- Holten Lützhøft, H.-C.; Eriksson, E.; Scholes, L.; Donner, E.; Wickman, T.; Sörme, L.; Lecloux, A.; Ledin, A. (2007). Database presenting basic information on the PPs, Deliverable 3.1 of the ScorePP project, p. 1-3 + appendix 1 (Powerpoint presentation: D3.1 Compilation of PP Inherent Properties) and appendix 2 (database, electronically available on www.scorepp.eu from August 2007).
- Syracuse Research Corporation (1999). Interactive PhysProp Database Demo. <http://www.syrres.com/esc/physdemo.htm> (accessed 15 July 2007).
- The Merck Index. (2006). An Encyclopedia of Chemicals, Drugs, and Biologicals, Fourteenth Edition, Maryadele J. O'Neil, Patricia E. Heckelman, Cherie B. Koch, Kristin J. Roman, Eds. (Merck & Co., Inc., Whitehouse Station, NJ, USA).
- Tomlin, C. (ed.) (2005). The e-Pesticide Manual 3.2. British Crop Production Council.
- US EPA (2004). Technology Transfer Network Clearinghouse for Inventories & Emissions Factors, SCC classification status: February 2004. <http://www.epa.gov/ttn/chief/codes/index.html> (accessed 15 July 2007).
- US National Library of Medicine (2006). Hazardous Substance Data Bank (HSDB). <http://www.toxnet.nlm.nih.gov/cgi-bin/sis/htmlgen?HSDB> (accessed 15 July 2007).