

# The Analysis of SIIR Mathematical Model Time Delay as The Solution of Tuberculosis Transmission in South Sulawesi

Syafruddin Side<sup>1</sup>, Wahidah Sanusi<sup>1</sup>, Muh. Rifandi<sup>2</sup>, and Andi Muh. Ridho Yusuf S.A.P.<sup>1</sup>

<sup>1</sup>Department of Mathematics, Universitas Negeri Makassar, Indonesia

<sup>2</sup>Department of Mathematics, Universitas Negeri Sulawesi Barat, Indonesia

**Abstract.** This study discusses the numerical solution of the Susceptible-Infected-Recovered (SIIR) transmission model for Tuberculosis (TB) transmission in South Sulawesi. The data used is secondary data from the number of Tuberculosis (TB) sufferers in South Sulawesi from the South Sulawesi Provincial Health Office. The discussion begins with a study of the SIIR model, then builds a time delay SIIR model on the spread of tuberculosis. Next, simulate the delay time SIIR model to find out the number of tuberculosis cases in South Sulawesi. Determining the parameters, simulation and analysis of the results in this study obtained a graph of the movement of the SIIR model of time delay of the spread of tuberculosis with real data. After analyzing the numerical simulation, it is seen that there is a tendency for the spread of Tuberculosis (TB) in South Sulawesi. The SIIR model is a four-dimensional non-linear differential equation. The results of the modeling are simulated using MatLab software to predict the number of TB cases so that early prevention measures are the government's attention to prevent the spread of Tuberculosis (TB) in South Sulawesi.

## 1 INTRODUCTION

Tuberculosis (TB) is a major health problem in Indonesia today. According to information from the South Sulawesi Ministry of Health (SulSel), the total number of tuberculosis cases in 2011 was 8,939 for him, up from 7,783 in the previous year. Takaral province led the number of cases with an increase of more than 109%, followed by Paré Paré 79%, Pinlang 75%, Makassar 70%, and finally Ruu 33% and Genepont 36%. Many factors, including the living environment, contribute to the increase in the number of patients. In addition, poor lighting in your home makes it easier for diseases to spread. A single tuberculosis patient can infect up to 10 people. Behavior is another factor. Tuberculosis is very common in HIV/AIDS patients. The contribution of unhealthy behavior reaches 5-10% each year, resulting in malnutrition [1]. According to Risesda's 2018 data, the number of tuberculosis cases in South Sulawesi province reached 50,127, based on doctors' diagnosis history. According to Risesdas 2019, the number of tuberculosis cases in South Sulawesi increased to 55,850 cases and decreased to 30,633 cases in 2020 [2].

The number of tuberculosis cases can be predicted using a mathematical model. He has created analyses of his SEIR model of TB infection with infectious disease models [3-16], [13], and his SIR model of tuberculosis infection with [14], but there is a time delay to tuberculosis and models of transmission that are not included. As a result, in this research, we examine the numerical simulations and analysis of a time-delayed SIIR model for tuberculosis prevalence in South Sulawesi. For parameter definition, analysis, and

simulation, this study employed secondary data on the number of tuberculosis cases in South Sulawesi.

## 2 RESEARCH METHOD

A theoretical and practical investigation is SIIR mathematical modeling of tuberculosis spread by time delay. The baseline reproduction number for the model is established using the generation matrix approach [7] and the SIR model of tuberculosis prevalence with extra delay time [12]. South Sulawesi Tuberculosis Cases: A Numerical Simulation Model Using Secondary Data [17] A Step to Prevent an Increased Rate of Tuberculosis Cases in Indonesia: Using Maple to Predict Cases.

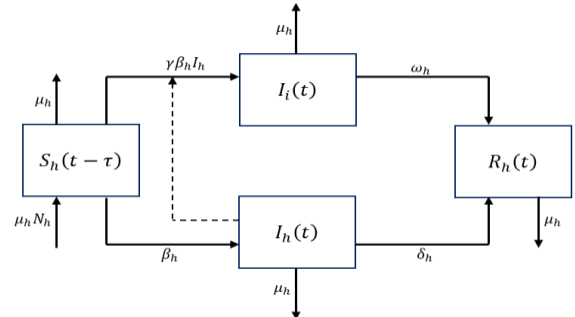

Fig. 1. Model Schematic of Tuberculosis Spread

## 3 RESULTS

### 3.1 SIIR Model

Four subpopulations make up the SIIR model of tuberculosis in South Sulawesi: Suscepted ( $S_h$ ), Infected

human ( $I_h$ ), Infected by Infected ( $I_i$ ), and Recovered ( $R_h$ ). Figure 3 below can be used to evaluate the variations in each human subpopulation of tuberculosis cases in South Sulawesi using the staggered SIIR model.

The variables and parameters used in the SIIR mathematical model of the spread of Tuberculosis.

**Table 1.** Definisi Variabel dan Parameter model SIIR Tuberculosis

Var/ Par	Informations
$N$	Total Population
$S_h$	The populations that are susceptible to tuberculosis
$I_h$	The population infected with tuberculosis due to the virus
$I_i$	The Population infected with tuberculosis due to infected humans
$R_h$	The population who have recovered from Tuberculosis
$\mu_h$	Assumed to be equal are the natural birth and death rates.
$\gamma\beta_h$	The rate of change of susceptible population to infected
$\beta_h$	The rate of change of the susceptible population to the infected population due to the virus
$\omega_h$	The rate of change of the infected population as humans are infected to the recovered population
$\delta_h$	The rate of change of susceptible population to infected population due to virus to cured population
$t$	Time
$\tau$	Time Delay

Equation (1)-(4) can be used to evaluate the rate of change in the number of people in each subpopulation based on the SIIR model scheme for the spread of tuberculosis in South Sulawesi Province in Figure 1.

$$\frac{dS}{dt} = \mu_h N_h - \beta_h S_h(t - \tau) - \gamma\beta_h I_h(t) S_h(t - \tau) - \mu_h S_h(t - \tau) \quad (1)$$

$$\frac{dI_h}{dt} = \beta_h S_h(t - \tau) - (\mu_h + \delta_h) I_h(t) \quad (2)$$

$$\frac{dI_i}{dt} = \gamma\beta_h I_h(t) S_h(t - \tau) - (\mu_h + \omega_h) I_i(t) \quad (3)$$

$$\frac{dR}{dt} = \delta_h I_h(t) + \omega_h I_i(t) - \mu_h R_h(t) \quad (4)$$

### 3.2 Model Analysis

#### 3.2.1 The Equilibrium Point

To determine the disease-free equilibrium point, each equation in equation (1)-(4), must be equal to zero, that

is  $\frac{dS}{dt} = 0$ ,  $\frac{dI_h}{dt} = 0$ ,  $\frac{dI_i}{dt} = 0$ , dan  $\frac{dR}{dt} = 0$ , so that the equation (5) – (8)

$$0 = \mu_h N_h - \beta_h S_h(t - \tau) - \gamma\beta_h I_h(t) S_h(t - \tau) - \mu_h S_h(t - \tau) \quad (5)$$

$$0 = \beta_h S_h(t - \tau) - (\mu_h + \delta_h) I_h(t) \quad (6)$$

$$0 = \gamma\beta_h I_h(t) S_h(t - \tau) - (\mu_h + \omega_h) I_i(t) \quad (7)$$

$$0 = \delta_h I_h(t) + \omega_h I_i(t) - \mu_h R_h(t) \quad (8)$$

Additionally, for the disease-free equilibrium point and the endemic equilibrium point SIIR models for the transmission of tuberculosis, the values of ( $S_h$ ), ( $I_h$ ), ( $I_i$ ), and ( $R_h$ ) will be calculated using the simple substitution approach. A situation where tuberculosis does not spread and  $I = 0$  is the disease-free equilibrium point. Equation (9)-(12) is obtained by manipulating equations (5)-(8) algebraically.

$$S_h(t - \tau) = \frac{\mu_h N_h}{\beta_h + \gamma\beta_h I_h(t) + \mu_h} \quad (9)$$

$$I_h(t) = \frac{\beta_h S_h(t - \tau)}{\mu_h + \delta_h} \quad (10)$$

$$I_i(t) = \frac{\gamma\beta_h I_h(t) S_h(t - \tau)}{\mu_h + \omega_h} \quad (11)$$

$$R_h(t) = \frac{\delta_h I_h(t) + \omega_h I_i(t)}{\mu_h} \quad (12)$$

It is possible to establish the disease-free equilibrium point of the SIIR model for the spread of tuberculosis in South Sulawesi by substituting each equation in equations (9)-(12) and first obtaining the value of  $I = 0$  in equation (13).

$$(S_h(t - \tau), I_h(t), I_i(t), R_h(t)) = (N_h, 0, 0, 0) \quad (13)$$

In order to determine the endemic equilibrium point value for the SIIR model of the transmission of tuberculosis in South Sulawesi, each equation in equations (9)-(12) must be substituted, and the basic reproduction number must be taken into consideration in equation (14).

$$(S_h^*(t - \tau), I_h^*(t), I_i^*(t), R_h^*(t)) = \begin{pmatrix} \frac{N_h}{R_0} \\ \frac{\mu_h(R_0 - 1)}{\beta_h(1 + \gamma)} \\ \frac{\gamma\mu_h(R_0 - 1)}{\beta_h(1 + \gamma)} \\ \frac{(\delta_h + \gamma\omega_h)(R_0 - 1)}{\beta_h(1 + \gamma)} \end{pmatrix} \quad (14)$$

#### 3.2.2 Basic Reproduction Number

The next generation matrix approach is used to calculate the basic reproduction number. This matrix is created by taking into account both the positive and negative aspects of the diseased population's transmission rate.

Equation shows the formula for calculating the basic reproduction number in equation (15).

$$K = F' \cdot (V')^{-1} \quad (15)$$

Considering the set of equations (2) and (3), then:

$$\frac{dI_h}{dt} = \beta_h S_h(t - \tau) - (\mu_h + \delta_h) I_h(t)$$

$$\frac{dI_i}{dt} = \gamma \beta_h I_h(t) S_h(t - \tau) - (\mu_h + \omega_h) I_i(t)$$

so that it can be acquired

$$F = \begin{bmatrix} \beta_h S_h(t - \tau) \\ \gamma \beta_h I_h(t) S_h(t - \tau) \end{bmatrix}$$

$$F' = \begin{bmatrix} \beta_h S_h(t - \tau) & 0 \\ \gamma \beta_h I_h(t) S_h(t - \tau) & 0 \end{bmatrix} \quad (16)$$

$$V = \begin{bmatrix} (\mu_h + \delta_h) I_h(t) \\ (\mu_h + \omega_h) I_i(t) \end{bmatrix}$$

$$V' = \begin{bmatrix} \mu_h + \delta_h & 0 \\ 0 & \mu_h + \omega_h \end{bmatrix} \quad (17)$$

The matrix equation (17) inverse is

$$(V')^{-1} = \begin{bmatrix} \frac{1}{\mu_h + \delta_h} & 0 \\ 0 & \frac{1}{\mu_h + \omega_h} \end{bmatrix} \quad (18)$$

Using equation (15), we will then compute the eigenvalues of the K matrix.

$$K = \begin{bmatrix} \beta_h S_h(t - \tau) & 0 \\ \gamma \beta_h I_h(t) S_h(t - \tau) & 0 \end{bmatrix} \begin{bmatrix} \frac{1}{\mu_h + \delta_h} & 0 \\ 0 & \frac{1}{\mu_h + \omega_h} \end{bmatrix}$$

$$K = \begin{bmatrix} \frac{\beta_h S_h(t - \tau)}{\mu_h + \delta_h} & 0 \\ \frac{\gamma \beta_h I_h(t) S_h(t - \tau)}{\mu_h + \omega_h} & 0 \end{bmatrix} \quad (19)$$

The eigenvalues will then be found using the formula  $\det(\lambda I - K) = 0$ , where I is the identity matrix, after finding the K matrix in equation (19). The biggest eigenvalue ( $\lambda$ ) will be used to establish the fundamental reproduction number.

$$|\lambda I - K| = \left| \left( \lambda \begin{bmatrix} 1 & 0 \\ 0 & 1 \end{bmatrix} - \begin{bmatrix} \frac{\beta_h S_h(t - \tau)}{\mu_h + \delta_h} & 0 \\ \frac{\gamma \beta_h I_h(t) S_h(t - \tau)}{\mu_h + \omega_h} & 0 \end{bmatrix} \right) \right| = 0 \quad (20)$$

Consequently, in order to derive the eigenvalues from equation (20),

$$\lambda_1 = \frac{\beta_h S_h(t - \tau)}{\mu_h + \delta_h}$$

$$\lambda_2 = 0$$

Then the largest eigenvalue obtained is

$$\lambda_1 = \frac{\beta_h S_h(t - \tau)}{\mu_h + \delta_h} \quad (21)$$

so that, after substituting the disease-free equilibrium point value as in equation (21), the fundamental reproduction number is obtained.

$$R_0 = \frac{\beta_h N_h}{\mu_h + \delta_h} \quad (22)$$

### 3.2.3 Stability Analysis

It is possible to create the following jacobian matrix (J) using equations (1)-(4).

$$J = \begin{bmatrix} -(\mu_h + \gamma \beta_h I_h(t)) & -\beta_h S_h(t - \tau) - \gamma \beta_h S_h(t - \tau) & 0 & 0 \\ \beta_h I_h(t) & \beta_h S_h(t - \tau) - (\mu_h + \delta_h) & 0 & 0 \\ \gamma \beta_h I_h(t) & \gamma \beta_h S_h(t - \tau) & -(\mu_h + \omega_h) & 0 \\ 0 & \delta_h & \omega_h & -\mu_h \end{bmatrix} \quad (23)$$

**Theorem 1:** The disease-free equilibrium point of the Tuberculosis spread model is said to be stable if  $R_0 \leq 1$  and unstable if  $R_0 > 1$ .

**Proof:** To create a new matrix as in equation (24), substitute the disease-free equilibrium point into the J matrix in equation (23).

$$J = \begin{bmatrix} -\mu_h & -\beta_h N_h - \gamma \beta_h N_h & 0 & 0 \\ 0 & \beta_h N_h - (\mu_h + \delta_h) & 0 & 0 \\ 0 & \gamma \beta_h N_h & -(\mu_h + \omega_h) & 0 \\ 0 & \delta_h & \omega_h & -\mu_h \end{bmatrix} \quad (24)$$

the equation matrix (24) with the following description's eigenvalues.

$$|\lambda I - J| = 0$$

$$|\lambda I - J| = \left| \begin{bmatrix} \lambda & 0 & 0 & 0 \\ 0 & \lambda & 0 & 0 \\ 0 & 0 & \lambda & 0 \\ 0 & 0 & 0 & \lambda \end{bmatrix} - \begin{bmatrix} -\mu_h & -\beta_h N_h - \gamma \beta_h N_h & 0 & 0 \\ 0 & \beta_h N_h - (\mu_h + \delta_h) & 0 & 0 \\ 0 & \gamma \beta_h N_h & -(\mu_h + \omega_h) & 0 \\ 0 & \delta_h & \omega_h & -\mu_h \end{bmatrix} \right| = 0$$

$$|\lambda I - J| = \left| \begin{bmatrix} \lambda + \mu_h & \beta_h + \gamma \beta_h N_h & 0 & 0 \\ 0 & \lambda - \beta_h N_h + (\mu_h + \delta_h) & 0 & 0 \\ 0 & -\gamma \beta_h N_h & \lambda + \mu_h + \omega_h & 0 \\ 0 & -\delta_h & -\omega_h & \lambda + \mu_h \end{bmatrix} \right| = 0 \quad (25)$$

Next, substitute S in equation (25) so that

$$\begin{aligned}
 &(\lambda + \mu_h)(\lambda - \beta_h N_h + \mu_h + \delta_h)(\lambda + \mu_h + \omega_h) \\
 &(\lambda + \mu_h) = 0 \tag{26} \\
 &(\lambda + \mu_h)(\lambda + (\mu_h + \delta_h)(R_0 - 1))(\lambda + \mu_h + \omega_h) \\
 &(\lambda + \mu_h) = 0
 \end{aligned}$$

If all the signs of each term are positive, equation (26) will have all negative roots in accordance with Descartes' sign rule. The disease-free equilibrium point is therefore stated to be stable if  $R_0 \leq 1$ , and unstable if  $R_0 > 1$ .

**Theorem 2:** The mathematical model of the asymptotically stable endemic equilibrium point of tuberculosis.

**Proof:** If  $I = 0$ , the endemic equilibrium point holds, and a new matrix is created using the J matrix in equation (23), as shown in equation (27).

$$J = \begin{bmatrix} -\mu_h R_0 & -\frac{\beta_h N_h (1 + \gamma)}{R_0} & 0 & 0 \\ \frac{\mu_h (R_0 - 1)}{1 + \gamma} & \frac{\beta_h N_h}{R_0} - (\mu_h + \delta_h) & 0 & 0 \\ \frac{\mu_h \gamma (R_0 - 1)}{1 + \gamma} & \frac{\gamma \beta_h N_h}{R_0} & -(\mu_h + \omega_h) & 0 \\ 0 & \delta_h & \omega_h & -\mu_h \end{bmatrix} \tag{27}$$

Then look for the eigenvalues with the following description:

$$\begin{aligned}
 &|\lambda I - J| = 0 \\
 &\left( \begin{array}{c} \lambda \\ \lambda \\ \lambda \\ \lambda \end{array} \begin{bmatrix} 1 & 0 & 0 & 0 \\ 0 & 1 & 0 & 0 \\ 0 & 0 & 1 & 0 \\ 0 & 0 & 0 & 1 \end{bmatrix} \right. \\
 &\left. - \begin{bmatrix} -\mu_h R_0 & -\frac{\beta_h N_h (1 + \gamma)}{R_0} & 0 & 0 \\ \frac{\mu_h (R_0 - 1)}{1 + \gamma} & \frac{\beta_h N_h}{R_0} - (\mu_h + \delta_h) & 0 & 0 \\ \frac{\mu_h \gamma (R_0 - 1)}{1 + \gamma} & \frac{\gamma \beta_h N_h}{R_0} & -(\mu_h + \omega_h) & 0 \\ 0 & \delta_h & \omega_h & -\mu_h \end{bmatrix} \right) \\
 &= 0 \\
 &\begin{bmatrix} \lambda + \mu_h R_0 & \frac{\beta_h N_h (1 + \gamma)}{R_0} & 0 & 0 \\ -\frac{\mu_h (R_0 - 1)}{1 + \gamma} & \lambda - \frac{\beta_h N_h}{R_0} + (\mu_h + \delta_h) & 0 & 0 \\ -\frac{\mu_h \gamma (R_0 - 1)}{1 + \gamma} & -\frac{\gamma \beta_h N_h}{R_0} & \lambda + \mu_h + \omega_h & 0 \\ 0 & -\delta_h & -\omega_h & \lambda + \mu_h \end{bmatrix} \\
 &= 0
 \end{aligned}$$

To Obtained :

$$\begin{aligned}
 0 = &(\lambda + \mu_h)(\lambda + \mu_h + \omega_h) \left[ (\lambda + \mu_h R_0) \left( \lambda - \frac{\beta_h N_h}{R_0} + \right. \right. \\
 &\left. \left. (\mu_h + \delta_h) \right) + \left( \frac{\beta_h N_h (1 + \gamma)}{R_0} \right) \left( \frac{\mu_h (R_0 - 1)}{1 + \gamma} \right) \right] \tag{28}
 \end{aligned}$$

$$\begin{aligned}
 0 = &(\lambda + \mu_h)(\lambda + \mu_h \\
 &+ \omega_h) \left[ (\lambda + \mu_h R_0)(\lambda) \right. \\
 &\left. + \frac{\beta_h \mu_h N_h (R_0 - 1)}{R_0} \right]
 \end{aligned}$$

The equilibrium point is Asymptotically Stable, in accordance with Descartes' sign rule, if all the roots of the characteristic equation ( $\lambda$ ) are positive.

### 3.3 SIIR Model Simulation

Maple software was used to simulate the SIIR Mathematical Model for the Spread of Tuberculosis in South Sulawesi. Table 2 displays the beginning values ( $S_h(0)$ ), ( $I_h(0)$ ), ( $I_i(0)$ ), and ( $R_h(0)$ ) as well as the parameter values of the model utilized in this simulation.

**Table 2.** Initial value of variables and parameters of the SIR model TB transmission in South Sulawesi

Var/Par	Values	Source
$N$	8342000	[17]
$S_h$	8329824	[17]
$I_h$	8523	[17]
$I_i$	3653	[17]
$R_h$	1218	[17]
$\mu_h$	0.000035	[17]
$\gamma$	0.123111	[17]
$\beta_h$	0.003267	[17]
$\delta_h$	0.041230	[17]
$\varphi_h$	0.003866	[17]

When the values of the uncontrolled parameters in Tables 1 and 2 are substituted in Equation (1)–(4), which is equal with zero, the value of the equilibrium points of the SIIR model is achieved, and the following equations system (29)–(32) is produced:

$$\frac{dS_h}{dt} = 0.000035 - (0.003267 + 0.000402I_h + 0.000035)S_h \tag{29}$$

$$\frac{dI_h}{dt} = 0.003267S_h - 0.041265I_h \tag{30}$$

$$\frac{dI_i}{dt} = 0.000402I_h S_h - 0.003901I_i \tag{31}$$

$$\frac{dR_h}{dt} = 0.00150I - 0.00625R \tag{32}$$

The equilibrium points of the SIIR model of the transmission of endemic tuberculosis are provided by equations (49)–(52) :

$$\begin{aligned}
 &(S_h^*, I_h^*, I_i^*, R_h^*) \\
 &= (0.05380, 0.00499, 0.06479, 0.87640)
 \end{aligned}$$

In addition, a simulation of the SEIR mathematical model of the spread of tuberculosis in South Sulawesi is run by including a delay time.

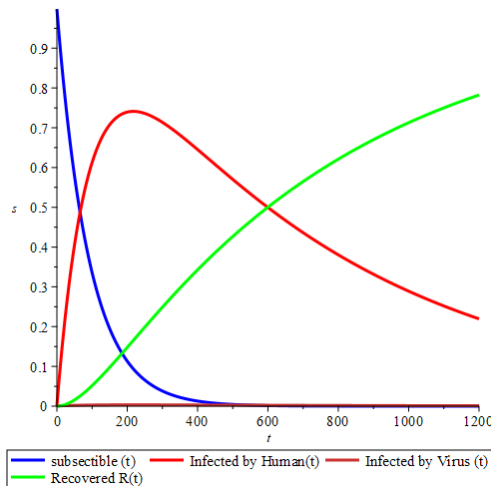

(a)

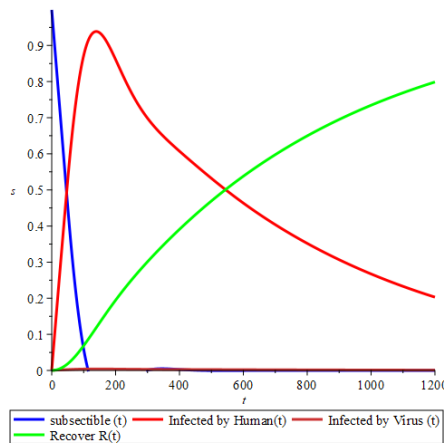

(b)

**Fig. 2.** The Graph of SIIR Model Simulation Result of Tuberculosis Spread without Delay Time (a) and with Time Delay,  $\tau = 60$  days (b)

Based on Figure 2.a. illustrates the results of the simulation carried out without adding the delay time to exposed individuals, it appears that in the absence of a delay time given to the SIIR distribution model of the spread of Tuberculosis, namely the value of the increase in individuals affected by tuberculosis infection due to interactions with infected individuals experienced a significant increase to 75% of the total population in the first 240 days and decreased for the next day to 28% of the total population on the 1200th day. For individuals whose range experienced a very significant decrease from 80% of the population to no population that spanned in less than 600 days. Individuals who recovered experienced a significant increase that reached 80% of the population in 1200 days and natural infections experienced a constant decline of less than 1% in 1200 days. Based on Figure 2.b. illustrates the results of the simulation carried out by adding the delay time to exposed individuals, it appears that with the delay time given to the SIIR model of the spread of Tuberculosis, the value of the increase in individuals

affected by tuberculosis infection due to interactions with infected individuals experienced a significant increase to 95% of the total population in the first 180 days and decreased for the next day to 28% of the total population on the 1200th day. For susceptible individuals there is a very significant decrease from 99% of the population to no susceptible population in less than 150 days. Individuals who recovered experienced a significant increase that reached 80% of the population in 1200 days and natural infections experienced a constant decline of less than 1% in 1200 days.

In general, the simulation results of the SIIR mathematical model for the spread of disease in the province of South Sulawesi are based on the values of the basic reproductive number or  $R_0$  which is a number that can explain the potential spread of disease in a population. In the SIIR model, the spread of tuberculosis infection is infected by other individuals, the value of  $R_0 = 3.848526$ , which means that the process of spreading the virus occurs, where each individual can spread the virus to three other individuals during the infectious period. So that it can be interpreted that the spread of tuberculosis infection based on the equilibrium points tends to be stable and the potential for its spread will be low with no delay in susceptible individual variables.

## 4 DISCUSSION

Previously, tuberculosis or lung disease had been studied by several researchers [18-20] by discussing the spread of tuberculosis that occurred in East Java and West Java. The results of the SEIR model study have shown that the number of cases of tuberculosis caused by viruses will continue to increase rapidly, while the number of cases of tuberculosis caused by human infection is not very influential and almost constant, and will decrease to near zero in the coming years, according to a previous study (21) with the title Numerical solution of SIR Model for Transmission of Tuberculosis by Runge-Kutta Method. These findings show that the SEIIR model, in particular, fits the Real data for the province of South Sulawesi in terms of the transmission of tuberculosis. However, the above research has not linked the spread of tuberculosis with the provision of a delay in the model and added a requirement for individuals whose range will change to infected individuals if they already have symptoms after interacting directly with infected individuals and without interacting with infected individuals. So that in this study using the SIIR model, the researcher gave a delay time to the individual variables that were ranged (susceptible) so as to produce different predictions from previous relevant studies [21]. For the variable given a delay of 60 days, the peak point for the spread of tuberculosis was less than 200 days with 95% of the total population and experienced a gradual decline until on the 1200th day, the peak of the spread had reached less than 30% of the total population. Total population in this study. So it can be concluded that the spread of tuberculosis in the population with a given time delay, will make an explosion of spread within a certain time

interval that can reach 95% of the infected population, and will still be stable to decrease to less than 30% for a given time delay and no time delay.

The SIIR Model of Tuberculosis Spread obtained the value of  $R_0 = 3,848526$  which means that the process of spreading the virus occurs, where each individual can spread the virus to three other individuals during the infectious period. So it can be concluded that the spread that occurs in populations without a time delay will have a high spread rate, but with a 60 day delay, the population distribution will increase significantly in less than 200 days until it reaches the highest level of distribution reaching 93% of the population.

## 5 CONCLUSION

Based on the discussion that has been carried out, the results of the mathematical model of the spread of tuberculosis by giving a time delay in the province of South Sulawesi with a 4-dimensional differential equation, the SIIR mathematical model of the spread of tuberculosis by giving a time delay in the province of South Sulawesi produce two equilibrium points, namely the free balance point and the equilibrium point of disease, both of which are stable. For the SIIR model of the spread of tuberculosis by giving a time delay, the value of  $R_0 = 3,848526$ , means that the process of spreading the virus occurs, where each individual can spread the virus to three other individuals during the infectious period. So it can be concluded that by giving a delay of 60 days will make the population spread will increase significantly in less than 200 days until it reaches the highest level of spread reaching 93% of the population.

## 6 ACKNOWLEDGEMENT

We appreciate the financial assistance from PD DIKTI No. 2413/UN36.11/LP2M/2022. Thank you as well to the South Sulawesi Provincial Health Office for providing the research's supporting data.

## References

- 1 A. Hermi, Angka kematian TBC di Sulsel tinggi, (2012)  
<http://www.aisyiyahsulselpedulid.com/2012/12/angka-penderita-tbc-di-sulsel-tinggi.html>. Accessed 9 March 2014.
- 2 TB. Yamali, Tuberculosis Sulawesi Selatan, (2021). <https://www.yamalitb.or.id/>. Accessed 29 Dec 2021.
- 3 T. Ashley, S. Jacqueline, S. John S, Modeling the spread of Tuberculosis in a closed population, (2010).  
[http://educ.jmu.edu/~strawbem/math\\_201/final\\_reports/Scotti\\_Takahashi\\_Spreadbury\\_Final.pdf](http://educ.jmu.edu/~strawbem/math_201/final_reports/Scotti_Takahashi_Spreadbury_Final.pdf). Accessed 20 Apr 2014.
- 4 I.K. Dontwi, D. Obeng, E.A. Andam, L. A. Obiri, British Journal of Mathematics & Computer Science, **4**(3), 402-4025, (2010).
- 5 Idianto, Bayu, K. Nilamsari, Buletin Ilmiah Mat. Stat. dan Terapannya, **2**(3), 173-182, (2013).
- 6 K, Queena, B.O. Tjokorda, E.D. Made, e-jurnal Matematika, **1**(1), 52-58, (2012).
- 7 S. Side, A, Advanced Science Letters, **21**(2), 137-139, (2015).
- 8 Y.M. Rangkuti, S. Side, M.S.M. Noorani, Journal of Mathematical and Fundamental Sciences, **46A**(1), 91-105, (2014).
- 9 S. Side, M.S.M Noorani, International Journal of Simulation and Process Modelling (IJSPM), **8**, (2/3), 177-184, (2013).
- 10 B. Poerwanto, R.Y. Fa'Rifah, W. Sanusi, S. Side, Journal of Physics: Conference Series **1028**(1), 012113, (2018).
- 11 W. Nur, H. Rachman, N.M. Abdal, M. Abdy, Journal of Physics: Conference Series **1028** (1), 012117, (2018).
- 12 S. Side, M.S.M Noorani, *World journal of modeling and simulation*, **9** (2), 96-105, (2013).
- 13 S. Side, U. Mulbar, S. Sidjara, W. Sanusi, *A SEIR Model for Transmission of Tuberculosis*, in AIP Conference Proceedings 1830 (1), 020004, (2017).
- 14 S. Side, A.M. Utami, M.I. Pratama, *Numerical solution of SIR model for transmission of tuberculosis by Runge-Kutta method*, in Journal of Physics: Conference Series 1040 (1), 012021, (2018).
- 15 P. Putri, Universitas Jember, (2013).
- 16 Tulus, Bulletin of Mathematics, **4**(1), 17-24, (2012).
- 17 S. Side, M.I. Pratama, N.R. Ramadhan, W. Sanusi, International Journal of Scientific and Technology Research, **9** (2), 816-820, (2020).
- 18 H.P. Rizky, W. Pramesti, G. Anuraga, Indonesian Journal of Statistics and Its Applications, **4**, 164 – 178, (2020).
- 19 C. Wulandari, Z. Maritska, Jurnal Kedokteran dan Kesehatan, **9** (2022).
- 20 Kristy, Jajang, Jurnal Ilmiah Matematika dan Pendidikan Matematika (JMP), **13** (2), 57-70, (2021).
- 21 S. Side, *Numerical solution of SIR model for transmission of tuberculosis by Runge-Kutta method*, in J. Phys Conf. Ser. 1040 012021, (2018).