



AIAS 2017 International Conference on Stress Analysis, AIAS 2017, 6-9 September 2017, Pisa, Italy

Injection molding. Influence of process parameters on mechanical properties of polypropylene polymer. A first study.

E. Farotti^{a*}, M. Natalini^b

^aPh.D. student, ^bJRF

Department of Industrial Engineering and Mathematical Sciences (DIISM), Università Politecnica delle Marche, Ancona 60131, Italy

Abstract

This paper shows the first study results of the mechanical characterization of a commercial polypropylene (PP) polymer. Before testing, a mold for injection molding process has been designed and realized. Three different specimens can be produced, for three different tests: tensile, Charpy and Hopkinson bar. In-cavity pressure and temperature sensors are installed next to the molded item to have direct information about process phases. After the description of the instrumentation, the correlation between injection molding input parameters and mechanical behavior of the material has been assessed. In particular, tensile tests have been carried out to investigate the influence of: melt temperature, mold temperature, packing pressure and cooling time. A Design of Experiment plan has been set up to establish the tests to be performed. Results show the influence of mold temperature and holding pressure on mechanical strength of the polymer.

Copyright © 2018 The Authors. Published by Elsevier B.V.

Peer-review under responsibility of the Scientific Committee of AIAS 2017 International Conference on Stress Analysis

Keywords: Injection Molding; Mechanical properties; Design of Experiments; Polypropylene; Mechanical characterization

1. Introduction

Polypropylene is a common thermoplastic polymer, largely used in industrial applications for the number of its properties, which make it versatile. PP components are semi-rigid, translucent, fatigue and heat resistant, tough and

* Corresponding author. Tel.: +39-3348184681

E-mail address: e.farotti@pm.univpm.it

chemically durable. The main manufacturing processes of polypropylene parts are extrusion and injection molding (IM). Through these technologies a numerous kind of products are available: buckets, bowls, crates, toys, medical components, washing machine drums, battery cases, bottle caps, etc.

In the large-scale industrial production world, plastic injection molded parts are getting a key role, because of their affordability and lightness, especially when there are no mechanical requirements. Although the process optimization focuses often on the reducing of cycle time (in accordance with dimensional and aesthetic specs), more and more frequently it's fundamental that the manufactured parts have mechanical performances. These last can be affected by process parameters, which can induce residual stresses to the component due to deformation at high shear rates, temperature and pressure. A right combination of these parameters can optimize the properties of the component.

In general, research activity on injection molded polymers' characterization by process parameters has been developed by several groups and different approaches have been carried. Typically, IM input parameters are: injection speed, melt temperature, mold temperature, packing time, packing pressure, cooling time.

An early study on PP properties was conducted by G. Kalay and M.J. Bevis (1997). They studied the influence of holding pressure, cooling time, melt temperature and injection speed on different molded parts (via conventional or SCORIM process). They reported the substantial increase in Young's modulus of moldings produced by SCORIM and the mechanical behavior about stiffness and impact resistance. Then, recent works concerning PP filled with calcium carbonate have been made by D. Kusić and A. Hančič (2016). Their aim has been the optimization of six molding conditions (melt temperature, packing time, cooling time, injection speed, packing and injection pressures) to reduce the shrinkage and warpage of a standardized test specimen, through the statistical Taguchi method.

In some cases, the research has been carried out controlling only one input parameter, as showed by M. Feldmann (2016). A polypropylene with a man-made cellulose fiber material was molded and mechanically tested, as well as SEM analyzed for a fiber length study. Results show an independence of Young's modulus from melt temperature, instead of tensile and Charpy (notched) impact strength.

Meanwhile, some researchers reported the influence of processing conditions for different polymers than PP. For example, U. A Dar et al (2016) made a study about the behavior of polycarbonate linked with injection velocity, packing pressure, cooling time, mold temperature, and melt temperature. They showed that the tensile stress increases with melt temperature and mold temperature, which helps the polymer to set a higher molecular orientation and have lower residual stresses. The higher is mold temperature, the lower is cooling rate: this condition increases part performances. Packing pressure and injection speed are not much significant to the polymer strength.

From the point of view of the analysis of experimental results, researchers have made use of different statistic approaches in order to investigate the correlation between molding conditions and part properties. In this study, a design of experiments (DoE) has been carried out to investigate the trend of mechanical strength of a commercial PP. The work approach is similar of the study made by Natalini et al (2013).

For the aim of the research, a mold for polymeric specimens has been manufactured, to carry out quasi-static and dynamic standard tests. Pressure and temperature sensors are installed next to the cavity mold, for the direct monitoring of filling and packing phases (in addition with the information of IM machine sensors). In this study, the controlled input parameters are: mold and melt temperatures, packing pressure and cooling time. From the effects analysis, it is possible understand which part properties are mostly dependent from IM parameters, for the specific polymer. In this paper, tensile test is the only mechanical test applied.

Nomenclature

PP	polypropylene
IM	injection molding
DoE	Design of Experiment
MT	melt temperature
MdT	mold temperature
Pp	packing pressure
Ct	cooling time
V/P	Switchover point

2. Experimental

2.1. Laboratory setting up

The laboratory instrumentation for this research activity is composed by an injection molding machine, a temperature control system, a mold and an in-cavity measurement system. Specimens are molded by an Arburg injection molding machine (Allrounder 320c). Main characteristics of the machine are summarized in Table 1. The thermoregulation of the water is made by a temperature control unit, which is capable to control the water temperature up to 90 °C, and then by a cooling system which remove the transferred heat during the molding process. A detailed description of the mold and the measurement system is presented in the following paragraphs.

Table 1. Injection molding machine specifications.

Max. screw stroke	100 mm
Max injection flow	146 cm ³ /s
Max. injection pressure	139 MPa
Screw diameter	30 mm
Max clamp force	50 t
Filling control	Volume rate control
Switch over control	Volume control

2.2. The mold

A family mold (Fig. 1-a) with a cold runner system has been manufactured: at every shot, specimens (Fig. 1-b) for tensile, Charpy and Hopkinson bar tests are molded. The 4th cavity is a sacrificial ring for Hopkinson test. In this way, parallel studies at the same molding and atmosphere conditions can be carried out. The tool is a two-plate single cavity mold, the parting line is the common surface for all the specimens, to minimize the production cost of the fixed platen. This mold has been designed to be modified in the most economical way and to be versatile in the molding of the specimens. In fact, the cavity in the mobile platen belongs to a removable part (possible future changes in the specimen dimensions, like thickness), the Charpy specimen can be molded in the notched version through an insert, and there are distributors which can interrupt the flow towards a specific sample. For every specimen, there is the possibility to have information about cavity pressure and temperature, as illustrated by Fig. 2-a. The total injected volume per shot is about 22 cm³. Cooling channels are outlined in Fig. 2-b.

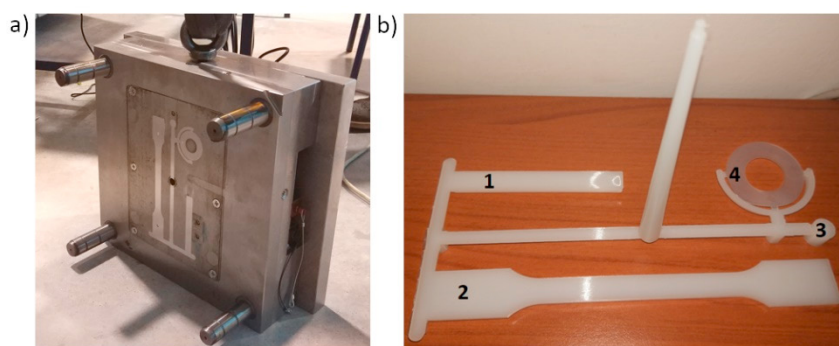

Fig. 1. (a) stationary platen; (b) mold cavities: 1-Charpy (unnotched); 2-Tensile test; 3-Hopkinson bar; 4-sacrificial ring

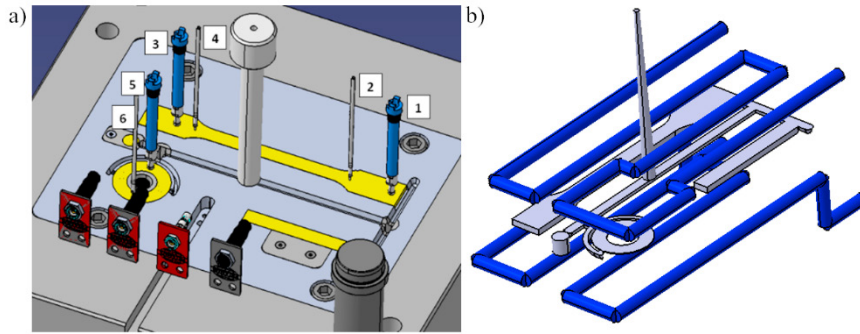

Fig. 2. (a) Possible sensor positions: 1-3-5 pressure, 2-4-6 temperature; (b) Part and cooling channels CAD models

2.3. Specimens geometries

For the tensile test, a dog-bone type specimen has been chosen. Dimensions are chosen according to ISO 527-2 standard: the gauge length is 75mm and the nominal cross section is 10x4 mm, gate section is 20x3 mm. The Charpy (unnotched) specimen is an 80x10x4 mm parallelepiped, according with ISO 179-1, gate section is 10x3 mm. Hopkinson specimen is a cylinder (D=10 mm, h=10 mm), with a 1x1.25 mm gate. Sacrificial ring dimensions are: Dext=36 mm, Dint=18.5 mm, thickness=0.5 mm (it's fed by three 3x0.4 mm gates). Alternatively, the thickness of the ring can be set to 0.3 mm by changing the insert. The sprue is cylindrical and tapered with starting and final diameters of 3.2 mm and 8 mm respectively with 1.2° draft angle. The geometries of specimens are shown in Fig. 3. It should be noted that, due to the volumetric shrinkage of the material, the actual dimensions of the specimens will be measured.

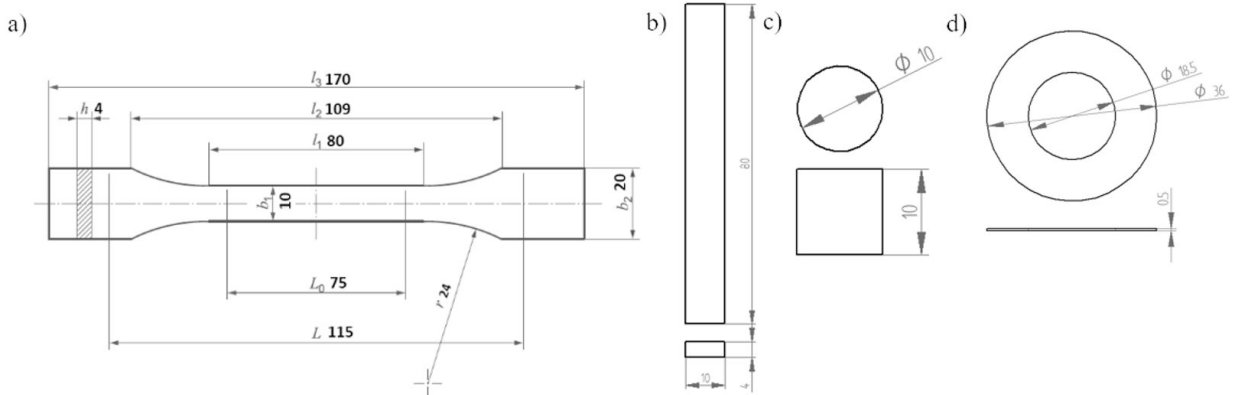

Fig. 3. Specimens geometries (dimensions in mm): (a) tensile; (b) Charpy unnotched; (c) Hopkinson bar; (d) sacrificial ring

2.4. Material

The material used in this study is Polypropylene Borealis-HF136MO, characterized by a good combination of mechanical and flow properties. Main properties of this material are listed in Table 2, while in Table 3 there are the typical processing conditions.

Table 2. Physical and mechanical properties of Polypropylene.

Property	Typical Value	Test Method
Density	905 kg/m ³	ISO 1183
Melt flow rate (230 °C / 2.16 kg)	20 g/10min	ISO 1133

Tensile Modulus (1 mm/min)	1500 MPa	ISO 527-2
Tensile Strain at Yield (50 mm/min)	9%	ISO 527-2
Tensile Stress at Yield (50 mm/min)	34 MPa	ISO 527-2
Charpy Impact Strength, notched (23 °C)	3 kJ/m ²	ISO 179/1eA

Table 3. General processing parameters for the material.

Process parameter	Value
Melt temperature	230-260 °C
Holding pressure	200-500 bar
Mold temperature	10-30 °C
Injection speed	As high as possible

2.5. Instrumentation and measurement chain

Pressure and temperature sensors are supplied by Priamus (6002Bx.x-102 and 4004Cx.x-101(-H) respectively). As the mechanical test is the tensile test, these sensors are installed next to the dog-bone specimen: pressure sensor is near the specimen gate, while the other is on the end of the dog-bone. Main characteristics are listed in Table 4 and 5.

Table 4. Priamus 6002Bx.x-102 specifications.

Property	Unit	Specification
Measuring range	Bar	0...2000
Sensitivity	pC/bar	5
Maximum melt temperature	°C	No limitation
Maximum mold temperature	°C	200
Deviation of linearity	%	< ±1

Table 5. Priamus 4004Cx.x-101(-H) specifications.

Property	Unit	Specification
Thermocouple	Type	N
Class		1
Standard operating temperature	°C	up to 600
Operating temperature range (cable)	°C	0...200
Maximum deviation	°C	dT = ±0.004xT or ±1.5

Signals pass through an amplifier and then sampled ($f_s = 100$ Hz) and stored into a PC. During the IM cycle, acquisition is triggered at mold closing. The measurement chain is presented below (Fig. 4). An example of acquired pressure and temperature graphs is shown in Fig. 5. It should be noted that temperature values are mainly influenced by the mold temperature, so the useful information of this sensor is the time of the flow front arrival.

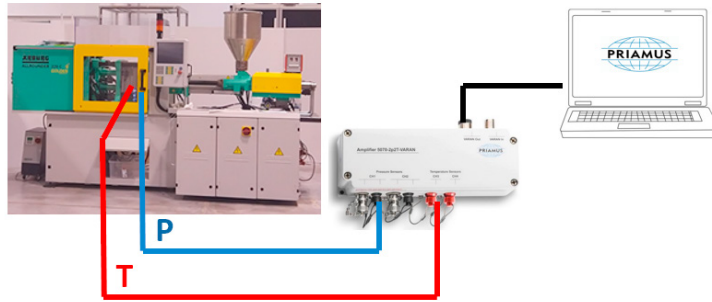

Fig. 4. Measurement chain

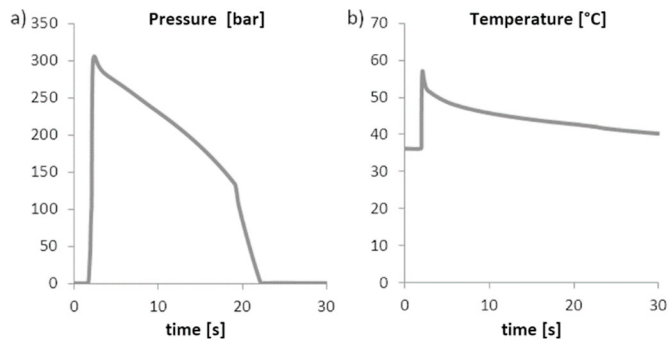

Fig. 5. (a) Cavity pressure; (b) Acquired temperature

2.6. Molding parameters and DoE plan

In this work, four IM process parameters were varied in order to evaluate any changes in mechanical behavior: melt temperature (MT), mold temperature (MdT), packing pressure (Pp) and cooling time (Ct). Reference values and range of variation are taken from the material data sheet, the molder experience and preliminary mold testing.

In particular, the molding conditions are the following:

- Flow rate: 30 cm³/s (by molder). Fill time is consequently about 0.7 s
- Switchover point (V/P): about 95÷99% of filled volume
- Melt temperature: 200÷260 °C (by data sheet)
- Mold temperature: 30÷60 °C (by data sheet)
- Packing pressure: 22÷42 MPa (preliminary tests)
- Packing time: 17 s (preliminary tests)
- Cooling time: 26÷52 s (by molder)

The range of MT has been modified from original data sheet in order to expect sensible changes in material properties, whereas the MdT range has been shifted from original due to the inability of actual cooling system to reach very low mold temperatures. For Pp, values correspond to the injection pressure at switchover point at higher and lower MT and MdT.

Packing time has been chosen after some preliminary tests, in which this parameter has been gradually increased. From what it has been observed, part weight has not had a substantial increase from 17 s. Moreover, the pressure graph has a slope not so vertical as it can be seen at short holding time.

Reference cooling time has been chosen by the molder experience on part with similar dimension.

Once all processing parameters are defined, the DoE has been planned. A complete 2^k factorial plan with face centered CCD (central composite design) has been adopted (D. C. Montgomery, 2001, Mancini et al, 2011). The

number of test to perform is expressed by the formula 2^k+2k+1 , where k is the number of monitored variables, for a total of 25 in this case. As a convention, let normalize the molding condition values to -1, 0, +1 which represent respectively the lowest, middle and highest values of their range (Table 6).

Table 6. DoE normalized variables.

	MT [°C]	MdT [°C]	Pp [MPa]	Ct [s]
-1	200	30	22	26
0	230	45	32	43
+1	260	60	42	52

3. Results and discussion

In this work the adopted sacrificial ring is the 0.3 mm thick. Despite the failure to fill all the mold cavity, due to the very low thickness of the ring and to the low injection speed, tensile properties of PP are investigated. For every DoE test 10 shots have been performed, in order to evaluate a statistical repeatability of the molding process. Cavity pressure and temperature are acquired for 30 s, a sufficient acquisition time to get all main information.

Data are investigated by means of usual statistic tools to evaluate effects and interactions: the variance analysis (ANOVA) suggests the significant influencing parameters. In general, model F-values indicate the consistence of the response functions.

3.1. Tensile test

For each of 25 batches, tensile tests have been carried out according to ISO 527-1 and 527-2. Only 8 specimens per lot have been pulled, the remaining will be chemically analyzed. The investigated mechanical properties are Yield stress (σ_y) and Young's modulus (E). For Polypropylene, the standard defines Yield stress as the maximum value in the σ - ϵ graph and E modulus as the slope calculated between $\epsilon = 0.05\%$ and $\epsilon = 0.25\%$. Displacement evaluation has been made with extensometer. According with the data sheet of the material, test starts at 1 mm/min of speed to evaluate E and then reaches 50 mm/min until test end. Section area of every specimen has been measured, whereas the considered gauge length is 50 mm. Test ends at the breaking of the specimen or at $\epsilon = 0.4$. A typical stress-strain curve is represented in Fig. 6-a, while the DoE cube (with Ct = 0) for Yield stress is reported in Fig. 6-b.

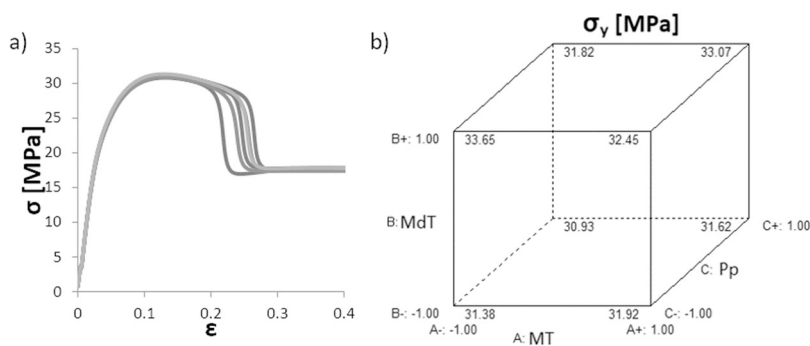

Fig. 6. (a) Example of stress-strain curves for test 14: MT (+1), MdT (-1), Pp (+1), Ct (+1); (b) DoE cube

For every batch, the distribution of results indicates the repeatability of the production system (for Yield stress the σ/μ ratio is less than 1.5%). Average yield stress of all tests is 32.11 MPa, with a variation of 3.05 MPa, corresponding to the 9.5% of the mean value of all DoE test. Similarly, for E modulus there is a variation of 213 MPa, corresponding to 14% of the average E (1253 MPa). Measured Yield stress is like the data sheet value, contrary of the Young's modulus, which is lower.

Focusing on the effect analysis, the Yield stress is firstly studied. A reduced cubic model is adopted. The ANOVA analysis shows that significant terms for the response function (p -value < 0.05) are MdT, Pp and the interaction with the other parameters. An example of a 3D response surface is shown in Fig. 7.

It is can be affirmed that in general the material strength increases with MdT. This behavior can be justified by the semi-crystalline nature of Polypropylene: at high mold temperatures, the melted material can cool slowly and the crystallization process takes longer to occur (polymer chains have time to get an ordered structure), thus giving rise to a material with a higher degree of crystallinity. Moving on to the other parameters, it can be seen that Pp gives the maximum strength at middle level: this means that material properties increase only until a determined pressure and then the part can be considered overpacked.

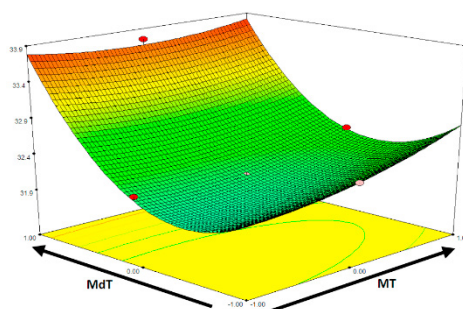

Fig. 7. Response surfaces for Yield stress: Pp (0), Ct (0)

In general, most of the specimens have been deformed plastically without reaching the breaking point at test end (Fig. 8-a). On 21 broken specimens, 19 have been moulded at MdT (+1), whereas the other at MdT (0). In particular, specimens of test 16 (MT +1, MdT +1, Pp +1, Ct +1) presented micro-voids uniformly distributed along the gauge length, which reduced the actual resistant section (Fig. 8-b). The high mold temperature may result in a major volumetric shrinkage at the ejection of the part, causing internal voids.

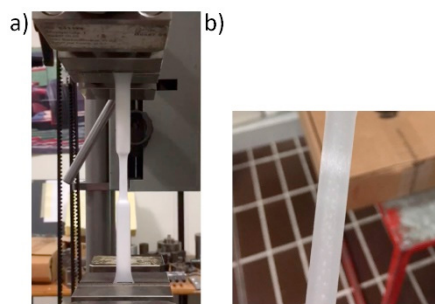

Fig. 8. Tensile test: (a) specimen deformed plastically; (b) micro-voids in test 16 specimens

Concerning the Young's modulus analysis, even if the fitting model is significant (p -value < 0.05) with a reduced cubic approximation, there are no molding conditions whose effect is clearly definable. The E behavior is conditioned by the interaction of the process parameters. In order to find a correlation, further tests might be necessary.

4. Conclusions and future developments

In this work a study of the injection molding process has been treated. Thanks to a mold for standard polymeric specimens, equipped with pressure and temperature sensors, the process been investigated using the DoE technique. The material used in the study is a commercial Polypropylene.

The effect of melt temperature, mold temperature, packing pressure and cooling time has been analyzed on the mechanical part properties. For each DoE test, 10 shots have been done and experimental data confirmed the repeatability of the process.

The ANOVA analysis suggested the significant terms for the response function of each investigated element. Results have been discussed on the basis of the material behavior and the physics of the process. Mold temperature is a determining factor of mechanical properties of the polymer, together with packing pressure. However, elevated values might lead to overpacking or fragile behavior of the part.

Future developments of this work may be the extension of the DoE plan to other uninvestigated parameters, like packing time or injection speed, and the mechanical characterization of the polymer through Charpy and Hopkinson bar tests. Moreover, in-cavity sensors information can be investigated. Chemical analysis will be conducted to match the mechanical behavior. Moreover, fiber-filled materials could be investigated.

Acknowledgements

The authors wish to thank Arburg, Priamus, Sverital, Regoplas, Hummel and their reference person for the Marche region, Mrs Simonelli, for providing laboratory equipment.

References

- Dar, U.A., Xu, Y.J., Zakir, S.M., Saeed, M.-U., 2016. The effect of injection molding process parameters on mechanical and fracture behavior of polycarbonate polymer. *Journal of Applied Polymer Science* 134 (7).
- Feldmann, M., 2016. The effects of the injection moulding temperature on the mechanical properties and morphology of polypropylene man-made cellulose fibre composites. *Composites Part A: Applied Science and Manufacturing* 87, 146-152.
- Kalay, G., Bevis, M.J., 1997. Processing and Physical Property Relationships in Injection-Molded Isotactic Polypropylene. 1. Mechanical Properties. *Journal of Polymer Science Part B: Polymer physics* 35, 241-263.
- Kusić, D., Hančič, A., 2016. Influence of Molding Conditions on the Shrinkage and Warpage Behavior of Standardized Test Specimens, AIP Conference Proceedings, Graz, Austria, paper # 020017.
- Mancini, E., Campana, F., Sasso, M., Newaz, G., 2012. Effects of cold rolling process variables on final surface quality of stainless steel thin strip. *International Journal of Advanced Manufacturing Technology* 61 (1-4), 63-72.
- Montgomery, D.C., 2001. Design and Analysis of Experiments. In: Wiley & Sons, New York.
- Montgomery, S., Gallo, V., 2012. Achieve process transparency with in-mold cavity sensors. *Plastics Technology* 58 (5), 39-41.
- Natalini, M., Sasso, M., Amodio, D., 2013. Comparison of numerical and experimental data in multi-objective optimization of a thermoplastic molded part. *International Polymer Processing* 28 (1), 84-106.