

**Original contribution**

Genetic clonal mapping of in situ and invasive ductal carcinoma indicates the field cancerization phenomenon in the breast

Maria P. Foschini MD^a, Luca Morandi PhD^a, Elisa Leonardi PhD^a,
Federica Flamminio MD^a, Yuko Ishikawa MD, PhD^a, Riccardo Masetti MD^b,
Vincenzo Eusebi MD, FRCPath^{a,*}

^aDepartment of Biomedical and Neuromuscular Sciences, “M. Malpighi” Anatomic Pathology Section, University of Bologna, Italy

^bDepartment of Surgery, Catholic University, Roma, Italy

Received 31 July 2012; revised 19 September 2012; accepted 28 September 2012

Keywords:

Breast;
Clonality;
Field cancerization;
In situ duct carcinoma;
Invasive duct carcinoma

Summary Nearly 80% of well-differentiated in situ duct carcinomas (g1 DCIS) have been shown to be multicentric (multilobar) lesions, while most in situ poorly differentiated duct carcinomas (g3 DCIS) were unifocal (unilobar) lesions. Here we present a clonality study of 15 cases of DCIS, all showing multiple foci. Twelve of these cases were associated with an invasive duct carcinoma. Fifteen cases of female breast cancer patients all showing multiple DCIS foci (5 g1 DCIS, 5 g2 DCIS, 5 g3 DCIS) were randomly selected and histologically studied using large histological sections. Care was taken to laser-microdissect DCIS foci that were most distantly located from one another in the same large section, and pertinent cells were genetically studied. Invasive duct carcinoma and ipsilateral lymph node metastases and/or contralateral lesions, whenever present, were additionally microdissected. DNA of neoplastic cells was purified, and the mtDNA D-loop region was sequenced. Genetic distance of different foci from the same case was visualized by phylogenetic analyses using the neighbor-joining method. Patients ranged in age from 36 to 87 years (mean 65.1). All 9 cases of widely spread DCIS were not clonal. Four of 6 cases that showed multiple adjacent foci were clonally related on mtDNA analysis. In the present series, 11/15 DCIS appeared as multiple synchronous primary breast tumors, genetically not related to one another. The present data enhance the view that breast can also show the field cancerization phenomenon, paralleling what has already been proposed in other organs.

© 2013 Elsevier Inc. Open access under [CC BY-NC-ND license](#).

1. Introduction

Large histological sections (LHS) are very useful to study normal and neoplastic breast tissue [1]. LHS allow not only

direct visualization of a large part of the breast glandular tree in one plane and enhance not only the correlation between mammography and pathology [2], but also give pertinent reliable information on multifocality, difficult to obtain using conventional paraffin blocks [3,4]. The breast parenchyma is subdivided into lobes, which are individual anatomical structures [5], each formed by a single galactophore duct that branches into segmental, subsegmental and terminal ducts,

* Corresponding author. Sezione Anatomia Patologica, Ospedale Bellaria, Via Altura 3, 40139 Bologna (Italy).

E-mail address: vincenzo.eusebi@unibo.it (V. Eusebi).

all ending in numerous acini [6]. Terminal ducts together with their relative acini have been named the “terminal duct lobular unit” (TDLU) [7]. Utilizing LHS, it has been shown that in situ and invasive lobular carcinoma is a multifocal [8] neoplastic lesion in over 50% of cases [9]. A study of 45 patients with in situ duct carcinoma (DCIS) using LHS for multifocality [3] showed that grade 1 DCIS was, in nearly 80% of the cases, a widespread multifocal condition involving more than one lobe and/or quadrant, while grades 2 and 3 DCIS were more circumscribed lesions, mostly confined to one lobe. It was then stated that grade 1 DCIS, in terms of multifocality, was more similar to previous observations regarding lobular in situ neoplasia/lobular in situ carcinoma (LIN2/LIN) [3,9].

In a seminal study using LHS on a series of 574 consecutive newly diagnosed breast carcinomas, Tot et al [10] found 75 cases (13%) of pure DCIS, of which 12% were unifocal (involving a single TDLU), 10% multifocal (involving several distant TDLUs with uninvolved breast tissue in between) and 24% diffuse (mainly involving large ducts). In the same study, invasive duct carcinomas (IDC) were unifocal in 62% of cases, multifocal in 24% and widely spread in 5%.

The reported incidence of multifocality (and multicentricity) of DCIS ranges from 0% to 78% according to different authors [11] to the point that multicentricity was denied by Page et al. [12], who stated that it is a misconception mostly related to artifacts. These remarkably different results for assessing the presence of multiple neoplastic foci in the same breast, obtained by different authors, appear to depend on the various methods of study employed, mostly based on traditional multiple-block sampling.

Although multifocality has been interpreted as the simultaneous presence of different neoplastic primaries in different lobes [3], it was felt [9] that some cases escape this rule due to the complexity of the ductal breast tree [5]. In fact, there are lobes that spread over a wide space and can mix with adjacent lobes to such an extent that it is impossible to separate one from the other at the morphological level, even using LHS [5].

The aim of this study was to try to find common or different mitochondrial DNA (mtDNA) mutations among multifocal DCIS that might reflect clonal or nonclonal features. The study was also extended to concurrent invasive carcinomas as well as metastases to axillary lymph nodes. For clonality, point mutations of the hypervariable D-loop region of mtDNA were studied by deep sequencing. Mutations were evidenced with phylogenetic analysis of neighbor-joining (NJ) trees [4,13].

2. Materials and methods

2.1. Patients

Fifteen randomly selected female patients, ranging in age from 36 to 87 years (mean 65.1) were included in the present

study. All patients had undergone mastectomies histologically studied with LHS. Criteria for selection of cases were the following: (a) multiple TDLUs/ducts involved by DCIS present within the same LHS; (b) enough material for microdissection and molecular analysis; (c) 5 cases each of g1 DCIS, g2 DCIS and g3 DCIS [14].

DCIS was graded according to current (2012) World Health Organization (WHO) criteria [11]. IDC, when present, was graded according to Elston and Ellis [15]. Nodal metastases, recurrences and contralateral lesions whenever present, were studied for clonal mtDNA analysis.

DCIS, per Tot's criteria [10,16], were considered unifocal when they involved several adjacent TDLUs, multifocal if they involved several distant TDLUs with uninvolved breast tissue in between, possibly containing normal glandular structures, and diffuse when large ducts were involved. IDC was considered unifocal when only one invasive area was observed in the large section, while it was considered multifocal when multiple invasive tumor areas were observed separated by uninvolved nonneoplastic breast tissue [10,16]. No cases of diffuse IDC or invasive lobular carcinoma or LCIS/LIN were present.

2.2. Tissue processing

Parallel large 5 mm thick slices were obtained from each mastectomy specimen, a routine procedure in our laboratory since 1995 [1]. Care was taken to slice each section perpendicularly to the skin, under mammographic guidance. Slices were then fixed in 10% buffered formalin and paraffin embedded as routine. From each large paraffin block, one 8 μ m hematoxylin and eosin-stained section was obtained [1].

2.3. Microdissection

Two to 7 foci of DCIS from each case were laser-microdissected for genetic study. Care was taken in capturing foci that were located at the farthest distance from one another in the same LHS.

Pertinent lesions were microdissected using the laser assisted SL μ cut Microtest (MMI GmbH distributed by Nikon, Firenze, Italy). Ten- μ m-thick sections were obtained, and unstained sections were deparaffinized with Bio-Clear (Bio-optica, Milan, Italy), rinsed in 100% to 80% ethanol and stained with hematoxylin and eosin. Breast glandular or epithelial tissue uninvolved by the neoplastic process and/or lymphocytes from reactive lymph nodes from the same case were also microdissected as control reference DNA. Tissue for microdissection from a pertinent block inclusive of the selected lesion was obtained from LHS. The block was melted and re-embedded to obtain the slide useful for the laser dissecting microscope.

The microdissected cells were placed in SL μ cut Transfer Film (Nikon, Firenze, Italy), and the DNA was digested

overnight at 55°C in 200 µL of tissue lysis buffer (ATL, QIAamp DNA Micro Kit, Qiagen GmbH, Hilden, Germany) containing 20 µL of proteinase K provided by the same supplier. A yeast carrier tRNA (Invitrogen, Milan, Italy) was added to the sample to improve DNA affinity with the subsequent isolation by Qiagen Spin Column (QIAamp DNA Micro Kit). Finally, DNA was eluted in 40 µL of ultrapure distilled water (DNAse/Rnase-free, Invitrogen) and immediately processed for polymerase chain reaction (PCR). An extraction control, to which no tissue was added, was processed in parallel with each sample extraction.

2.4. mtDNA deep sequencing and neighbor joining tree creation

DNA was purified and sequenced for the mtDNA D-loop region by the 454 Platform (GSJunior; Roche, Branford, CT). In brief, the mtDNA D-loop sequence analysis was performed by amplifying four segments of about 400 bp, covering the whole region from position 15995 to position 700, according to Anderson et al [17] as described in the human mitochondrial database [18]. Primers were designed using Primer3 [19], and their sequences are reported as

Supplementary Table 1. These primers were selected to avoid amplification of human mitochondrial pseudogenes in the nuclear genome [20]. To generate amplicons for the 454 NGS library, fusion primers were designed to contain specific mtDNA primers, the A and B sequencing adapters and the key sequence required for 454 NGS, and one of 14 different 10 bp multiplex identifier barcodes, according to the manufacturer's GS FLX Standard sequencing method.

PCR reactions were performed in a 25 µL volume containing 5 pmol of each forward and reverse primer using KAPA HiFi HotStart DNA Polymerase, following the instructions of the provider (Kapa Biosystems, Woburn, MA). PCR products were separated by electrophoresis on 3% agarose gel and purified using the AmpPure kit (Agencourt; Beverly, MA). Sequencing analysis was then performed on purified products using the GS Junior sequencer (Roche; Branford, CT) following the recommendations of the provider. The strands were screened bidirectionally. Filters were set to display sequence variances occurring in at least 10 reads with a threshold of 10% mutant reads using Amplicon Variant Analyzer (v. 2.7, Roche).

Phylogenetic and cluster analyses were conducted using MEGA version 4.0 following the NJ method and Kimura-2

Table 1 Clinical features of DCIS cases

Case	DCIS grade	Age (y)	Side	Concomitant IDC	Ln status	CLT	Follow-up
1	g1	77	L	absent	N0	absent	Alive and well 6 y
2	g1	57	R	IDC g1 IDC g2	N0	IDC g3, N0 synchronous	Alive and well 11 y
3	g1	52	R	absent	N0	IDC g1, DCIS, N+ 2 y earlier	Alive and well 10 y
4	g1	81	R	IDC g2	N0	absent	Died of other causes
5	g1	74	L	IDC g2	N0	absent	Alive and well 6 y
6	g2	87	L	absent	N0	IDC g2, N0 1 y earlier	Died of other causes
7	g2	63	R	IDC g2	N+	absent	Lung and bone MTS 5 y later
8	g2	83	R	IDC g3	N+	absent	Died of other causes
9	g2	68	L	IDC g2	N+	absent	Local skin recurrences 1 and 2 y later
10	g2	47	L	IDC g2	N0	absent	Alive and well 6 y
11	g3	65	L	IDC g3	N+	absent	Alive and well 2 y
12	g3	51	L	IDC g3	N0	absent	Alive and well 5 y
13	g3	57	R	IDC g3	N+	absent	Alive and well 2 y
14	g3	36	L	IDC g2	N0	absent	Alive and well 4 y
15	g3	78	L	IDC g3	N+	absent	Abdominal Ln and liver MTS 10 mo later

Abbreviations: g, grade; DCIS, ductal carcinoma in situ; R, right side; L, left side; Ln, lymph node; N0, lymph node negative; N+, lymph node positive; IDC, invasive duct carcinoma; CLT, contralateral breast; MTS, metastases.

Table 2 Histological features and molecular results of mtDNA analysis

Case	DCIS grade	Max distance (mm)	Focality	mtDNA		
				DCIS-DCIS	IDC-DCIS	MTS, CLT, REC
1	1	48	Multi	Not clonal	na	na
2	1	50	Multi	Not clonal	IDC related to closer DCIS	CLT not related to index lesions
3	1	46	Multi	Not clonal	na	CLT DCIS, CLT IDC, CLT MTS not related to index lesions but related among them
4	1	26	Multi	Not clonal	IDC related to closer DCIS	na
5	1	12	Multi	Not clonal	IDC related to closer DCIS	na
6	2	72	Multi	Not clonal	na	CLT not related to index lesions
7	2	35	Uni	Not clonal	IDC related to closer DCIS	MTS related to IDC
8	2	8	Uni	Clonal	IDC related to both DCIS	MTS not related to index lesions
9	2	30	Multi	Not clonal	IDC related to distant DCIS	MTS, REC not related to index lesions but related among them
10	2	26	Multi/Diff	Not clonal	IDC related to distant DCIS	na
11	3	30	Uni	Clonal	IDC not related to DCIS	MTS related to IDC
12	3	28	Uni	Clonal	IDC related to both DCIS	na
13	3	60	Uni	Clonal	IDC related to both DCIS	MTS not related to index lesions
14	3	29	Multi	Not clonal	IDC related to closer DCIS	na
15	3	30	Uni	Not clonal	IDC related to distant DCIS	MTS related to IDC

Abbreviations: DCIS, ductal carcinoma in situ; Uni, unifocal; Multi, multifocal; Diff, diffuse; IDC, invasive duct carcinoma; MTS, metastases; CLT, contralateral breast; REC, recurrence; na, not applicable.

parameter with Gamma model that corrects for multiple hits, taking into account transitional and transversal substitution rates and differences in the sites' substitution rates [13,21-23]. Every NJ tree was tested for standard error using the bootstrap method [13]. The genetic relationship among samples was determined taking into account their position in the phylogenetic tree together with the length of terminal branches, all regarded markers of genetic distance [23].

Multiple DCIS were considered clonal when they appeared to derive from the same tree node or if their tree path showed at the most one additional node with minimal branch length. Nonclonal DCIS samples were located in different branches of the root node or their path showed at least 2 different nodes. Samples of IDC as well as lymph node metastases were considered related or not related to the index DCIS or to each other taking into account their localization in the tree as well as branch lengths.

3. Results

The 15 patients here studied were female, ranging in age from 36 to 87 years (mean 65.1 years). The left breast was involved in 9, and the right in 6 cases. Mastectomies were preceded by preoperative vacuum-assisted core biopsies all diagnosed as B5 [14]. IDC was observed in 12 cases, and 6 cases had synchronous axillary nodal metastases. Follow-up was obtained in all cases, ranging from 1 to 11 years (mean 4.2 years). Two recurrences of invasive carcinoma were seen in case 9 at 12 and 24 months. Two cases presented distant

metastases (cases 7 and 15 after 60 and 10 months, respectively). Contralateral DCIS and IDC were seen in 3 cases (cases 2, 3 and 6). Case 2 was synchronous, while cases 3 and 6 had previous contralateral tumors diagnosed, respectively, 24 and 12 months earlier (Table 1).

3.1. Histology of DCIS

Multiple TDLUs/ducts involved by DCIS were present in all cases as this was one of the selection criteria. DCIS showed the same histological grade in every one of the several TDLUs/ducts present within the same LHS (Table 2).

Eight cases (5 grade 1, 2 grade 2 and 1 grade 3) were multifocal, that is, located in several TDLUs separated by uninvolved breast glandular tissue, and one was multifocal and diffuse (case 10). The maximum distance between the involved ducts ranged from 12 to 72 mm (mean, 37.7 mm). Six cases (2 grade 2 and 4 grade 3) were considered unifocal because no uninvolved glandular tissue was present between the involved ducts. In these latter 6 cases, the maximum distance between the involved ducts ranged from 8 to 60 mm (mean, 31.8 mm).

Twelve cases showed concomitant areas of IDC, which was unifocal in all but one (case 2) that showed 2 different areas of IDC separated by uninvolved breast glandular tissue.

3.2. mtDNA analysis

mtDNA analysis results have been summarized in Table 2, and complete phylogenetic trees are available in Supplementary Figures 1-3.

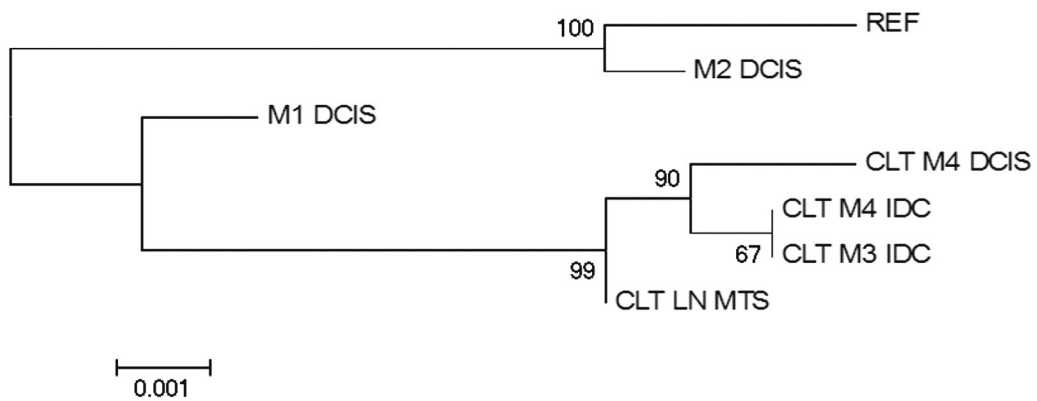
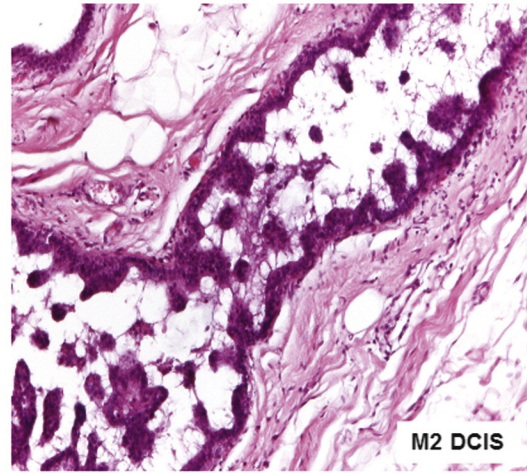
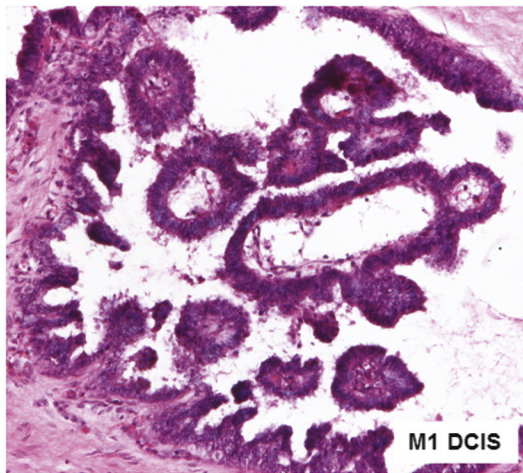
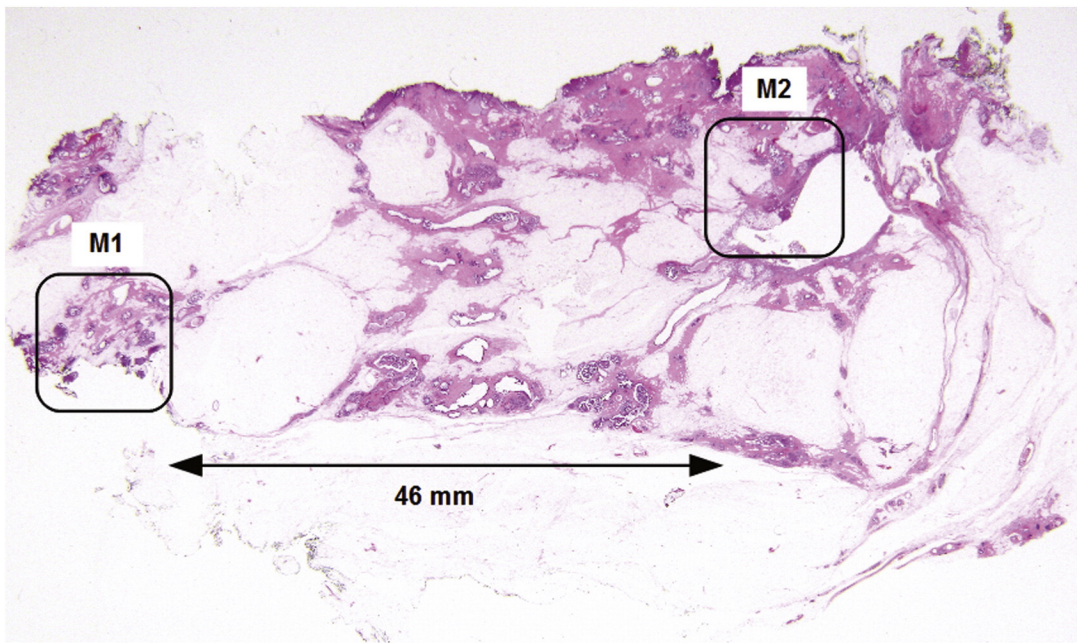

Fig. 1 Case 3: well differentiated DCIS. M1 and M2 are the areas of the microdissected in situ lesions, 46 mm apart. DCIS in M1 and M2 do not appear clonal in the phylogenetic tree as they are located in a different root branch. M3 and M4 are the microdissected areas of the invasive lesions on the contralateral breast. All contralateral lesions (DCIS, IDCs and LN MTS) are not related to the above DCIS lesions but are clonally related each other. Abbreviations: M, area of microdissection; DCIS, ductal carcinoma in situ; CLT, contralateral; IDC, invasive duct carcinoma; LN MTS, lymph node metastases; REF, reference tissue.

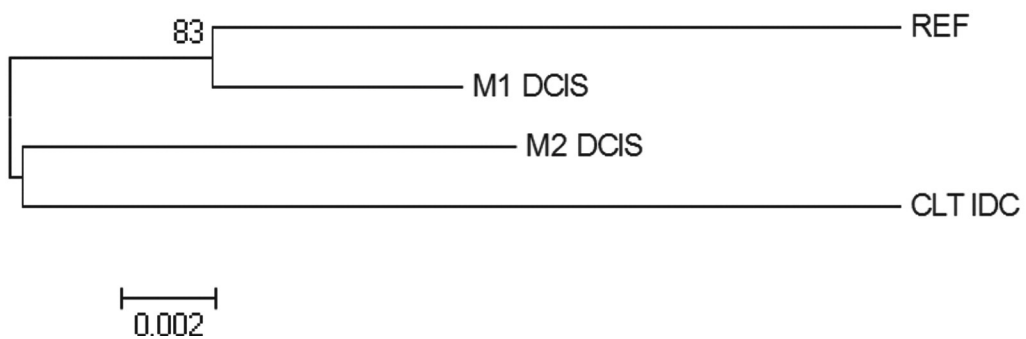
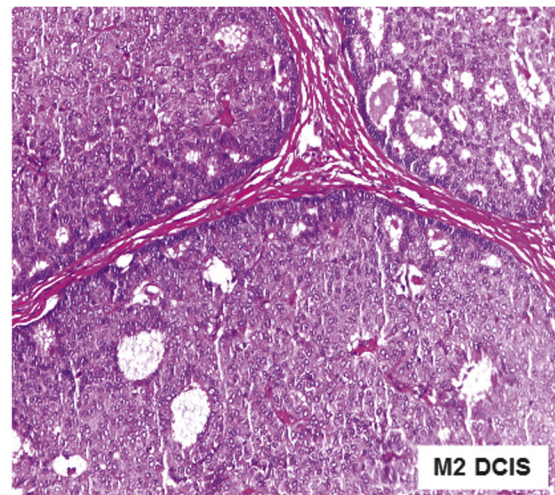
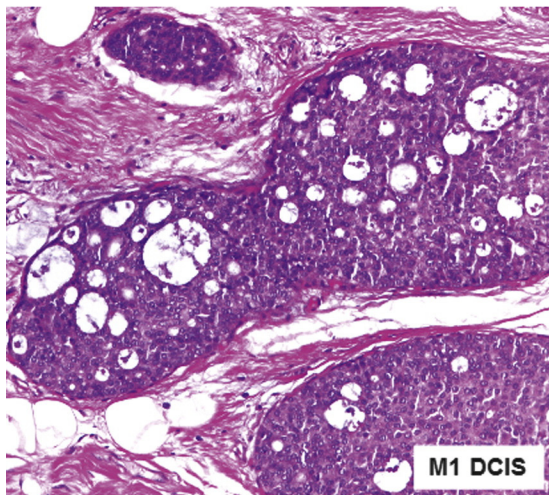
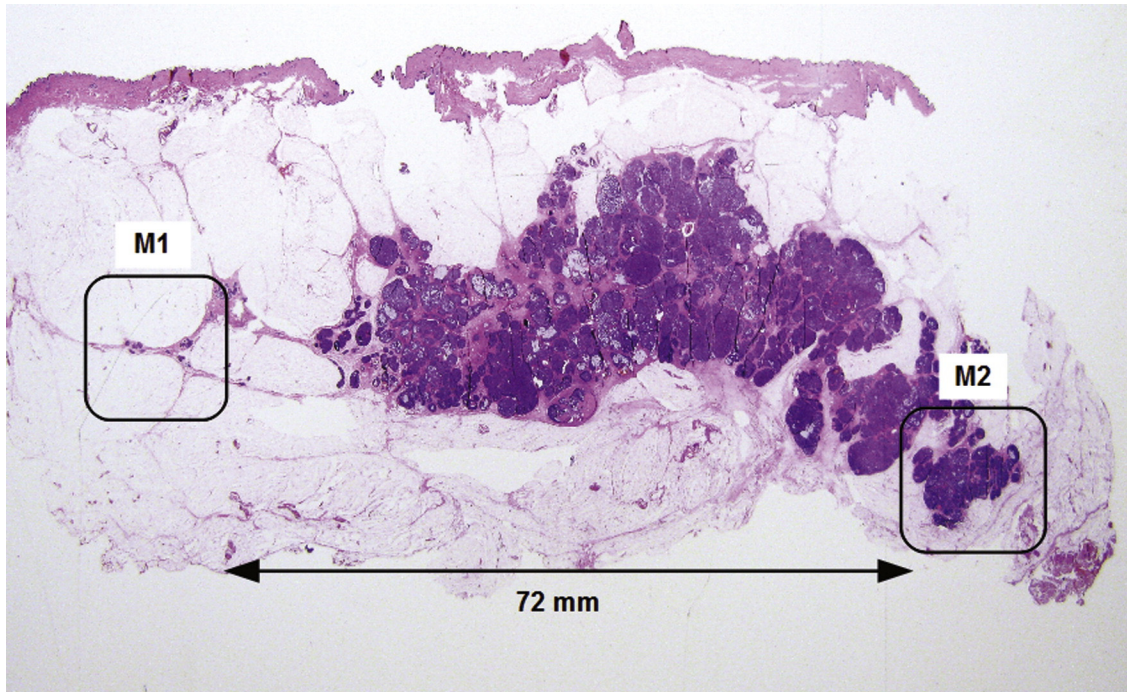

Fig. 2 Case 6: DCIS with intermediate differentiation. M1 and M2 are the areas of the microdissected in situ lesions, 72 mm apart. DCIS in M1 and M2 do not appear clonal in the phylogenetic tree as they are located in a different root branch. The contralateral IDC is not related to the above neoplastic lesions. Abbreviations: M, area of microdissection; CLT, contralateral; REF, reference tissue.

3.2.1. Multifocal DCIS

NJ trees derived from the deep sequencing of mitochondrial genome from all 8 cases classified as multifocal and case 10 classified as multifocal and diffuse on histology showed that the most distant foci were located in distant branches indicating phylogenetically different lesions (Figs. 1 and 2).

3.2.2. Unifocal DCIS

In 4 out of 6 cases (cases 8, 11, 12, 13) classified as unifocal on histology, the multiple dissected foci appeared phylogenetically similar (Fig. 3). In the remaining two cases (cases 7 and 15), the multiple foci were phylogenetically distant.

3.2.3. IDC

Eleven out of 12 cases showing IDC areas evidenced the invasive lesion phylogenetically related to at least one DCIS focus. Among these clonally related cases, 5 cases (cases 2, 4, 5, 7, 14) showed IDC phylogenetically related to the closer DCIS focus, and 3 cases (cases 8, 12, 13) showed IDC phylogenetically related to both foci of DCIS examined (the closest and the most distant). The only exception was case 11, where the IDC area appeared phylogenetically not related to the DCIS; nevertheless, the IDC area was located in a different quadrant with respect to the DCIS in this case.

3.2.4. Contralateral carcinomas

All the lesions located in the contralateral breast in cases 2, 3 and 6 were phylogenetically distant from their index lesions. In case 3, contralateral DCIS, IDC and axillary nodal metastases were phylogenetically related each other and different from the index lesion.

Lymph node metastases were located in a branch close to the related IDC in 3 out of 6 cases, while in three cases, they were phylogenetically distant from the related IDC. Skin recurrences of case 9 were related to the nodal metastasis.

4. Discussion

Several methods can be applied to evaluate clonality in tumor pathology. In the present study, the clonality assay was performed by mtDNA (D-loop) sequence analysis followed by neighbor-joining tree, which has been repeatedly validated in our laboratory [4,24-26]. This approach was chosen as it is little affected by low-quality genetic material obtained from formalin and paraffin embedded tissues that hamper consistent results from the other commonly used methods, including array comparative hybridization and X-linked methylation analysis. In addition, nuclear genetic aberrations can give selective advantage to a tumor population and therefore the same changes can be found at the same time in different clones [27]. Furthermore, the analysis of a noncoding region like mtDNA D-loop is

based on functionally silent mutations that are useful to indelibly mark each cell with a unique genetic fingerprint [28]. The high level of mutation rate in mtDNA also helps to increase the confidence of the test, avoiding false positive results stochastically obtained, as demonstrated by the bootstrap test [4,13].

Based on clonal analysis evaluated by mtDNA analysis, in the present series, all cases that were classified as multifocal DCIS on morphology appeared to be genetically different as the single DCIS foci were not clonally related to each other. On the contrary, 4 out of 6 cases regarded unifocal appeared to be clonal as the single DCIS foci were genetically related one another. Only 2 cases (cases 7 and 15) of the present series were exceptions to this rule. In spite of the fact that all the DCIS foci were contiguous, they did not appear to be clonally related. Therefore, in the present series, 11 out of 15 nonclonal DCIS can be considered multiple independent primary carcinomas.

The present data of multiple primary carcinomas suggest that the breast can be affected by the phenomenon called "field cancerization" by analogy with other organs [29,30]. The term "field cancerization" was introduced in 1953 by Slaughter and co-workers [31] to explain the presence of multiple squamous cell carcinomas observed in different areas of the oral cavity, all associated with a preneoplastic lesion. This observation has recently been confirmed by molecular techniques [32-34]. The same observation has since been found applicable to several organs, including the breast, to explain simultaneous multiple primaries [30].

The breast can be affected by multiple cancers located in different quadrants [11]. Eleven of the present DCIS were nonclonal, multiple independent in situ neoplasms. Similar results were shown by Volante et al [35], who found that two cases of low-grade DCIS and 6 cases of lobular in situ carcinoma appeared nonclonally related. Bilateral invasive breast carcinomas when associated to DCIS are considered independent primary tumors [11]. This view is in keeping with case 2, which showed 2 distinct bilateral invasive carcinomas with different morphology (one case was IDC grade 2, while the second area was grade 1). Both carcinomas were nonclonal but contained a genetically related DCIS. The same condition was observed evaluating contralateral carcinomas (cases 2, 3, 6), which appeared to be not clonally related to the index lesions.

In organs where the concept of field cancerization has been accepted for a long time, the epithelium surrounding the invasive carcinoma often shows the features of preneoplastic lesions. The same features can be observed in the breast where the in situ carcinoma is frequently associated with invasive carcinoma. In a previous study on the three-dimensional reconstruction of invasive and in situ lobular carcinoma, it has been shown that 78.6% of the areas of invasive lobular carcinoma contained concomitant foci of in situ lobular carcinoma [9]. Similarly, a frequent association between IDC and concomitant DCIS in the same area has been demonstrated by the same group [3]; the

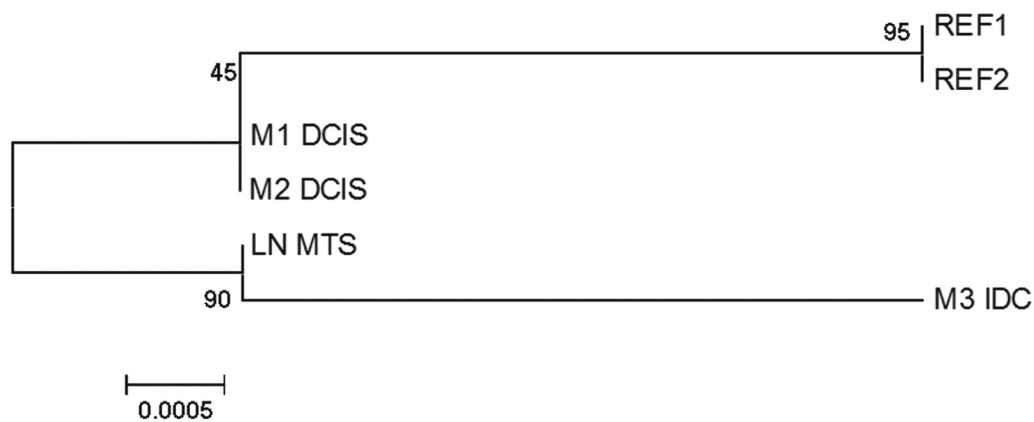
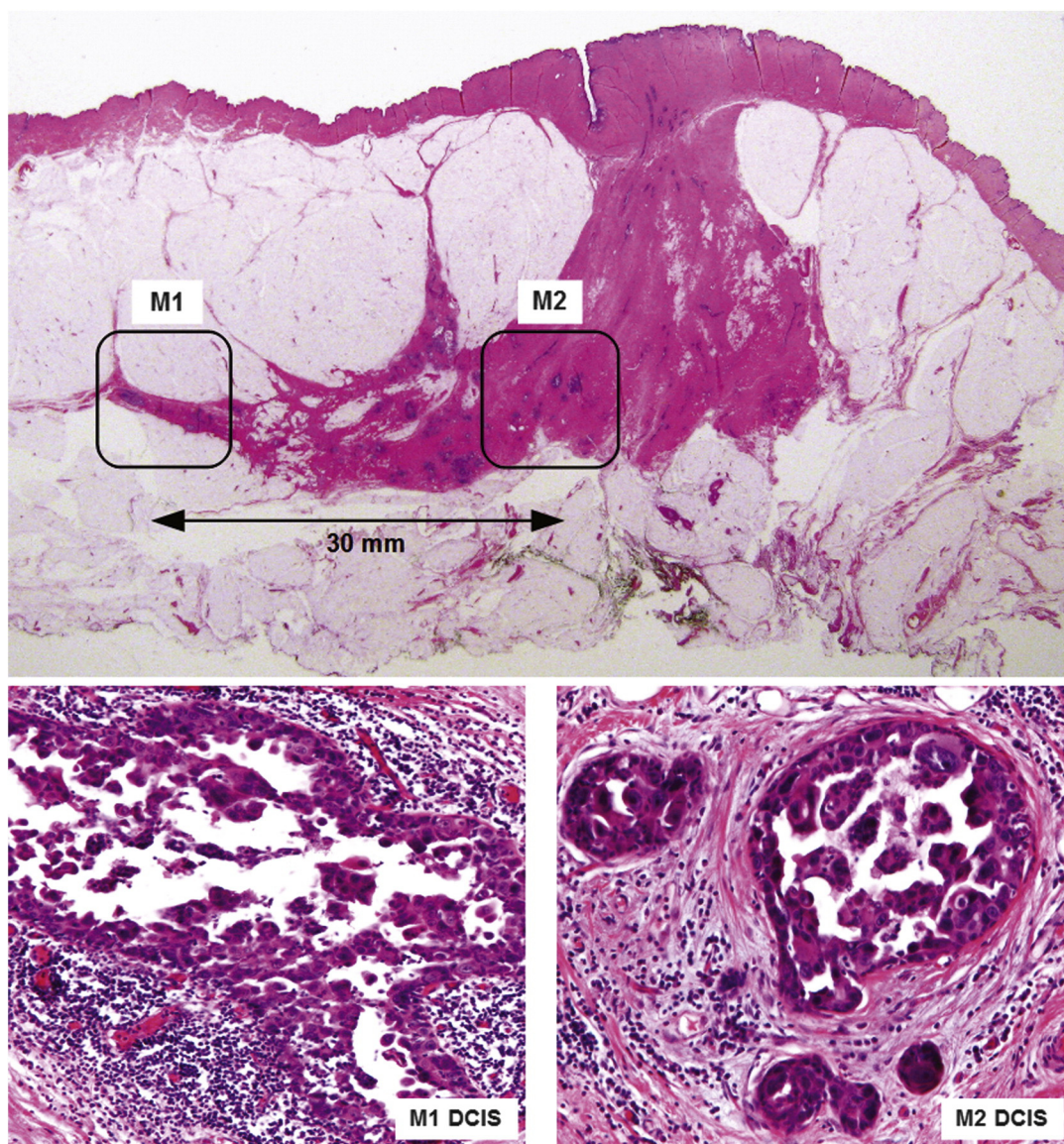

Fig. 3 Case 11: poorly differentiated DCIS. M1 and M2 are the areas of the microdissected in situ lesions, 30 mm apart. An area of g3 IDC (M3) is not included in the picture as it was present in another quadrant. DCIS in M1 and M2 appear clonal in the phylogenetic tree as they cluster in the same branch. IDC as well as LN metastases appear located in a different root branch. They are related each other, but not related to the in situ lesions. Abbreviations: M, area of microdissection; DCIS, ductal carcinoma in situ; IDC, invasive duct carcinoma; LN MTS, lymph node metastases; REF, reference tissue.

same results were obtained by Morandi et al [4,26] and by Aulmann et al [36] using molecular techniques. These authors demonstrated that in situ and invasive breast carcinoma, when intermingled together, are clonal lesions, thus confirming the strict relationship between concomitant in situ and invasive carcinomas [4,26]. Pertinently, in the present series, IDC areas were clonally related with at least one focus of DCIS.

Slaughter and coworkers [31] observed that in some cases, microscopic tumor foci grow independently and finally coalesce to produce a large carcinomatous lesion. In case 7 of the present series, DCIS and IDC, microdissected at the 2 opposite edges of the same wide neoplastic area, were composed of neoplastic clones not genetically related to each other.

Finally, in the field cancerization model of the oral cavity, after surgical removal of an invasive carcinoma, pre-neoplastic lesions might not be excised, thus developing into invasive carcinomas [32]. The same has been demonstrated in the breast by several studies performed independently using different molecular techniques that revealed genetic alterations in apparently normal glandular structures located around breast carcinomas [37].

The evaluation of the extent of mammary field cancerization is still open to question. According to Tot [6], breast carcinoma arises in a genetically altered mammary lobe and develops mainly along the lobular ducts and TDLUs. Cases 8, 11, 12 and 13 of the present series were characterized by multiple DCIS foci not separated by normal glandular structures. They all appeared clonally related, indicating that the carcinoma extended through the branches of the same lobe. Therefore it appears that in these cases the extent of the cancerized field might only be one lobe. In contrast, the cases presenting multifocal DCIS foci not clonally related on mtDNA analysis might represent involvement of multiple lobes, indicating a wider cancerized field. This latter event appears more frequent in cases of grade 1 DCIS.

In conclusion, the data here obtained indicate the following:

1. Most multifocal DCIS are phylogenetically distant, nonclonal lesions, which might indicate different synchronous primaries in different lobes of the same breast.
2. Contralateral DCIS and IDC were phylogenetically different from the index lesions. These data are probative for independent primaries of both breasts.
3. IDC phylogenetically close to concomitant DCIS is highly suggestive that the latter is a precursor.
4. All these data indicate that the breast can be affected by field cancerization.

Supplementary data

Supplementary data to this article can be found online at <http://dx.doi.org/10.1016/j.humphath.2012.09.022>.

Acknowledgments

Elisa Leonardi is recipient of a grant from Susan G. Komen Italia (Rome). Dr Christine M. Betts has kindly read and revised the manuscript.

References

- [1] Foschini MP, Tot T, Eusebi V. Large-section (macrosection) histologic slides. In: Silverstein MJ, editor. *Ductal carcinoma in situ of the breast*. 2nd ed. Philadelphia: Lippincott; 2002. p. 249-54.
- [2] Tot T, Tabar L. The role of radiological-pathological correlation in diagnosing early breast cancer: the pathologist's perspective. *Virchows Arch* 2011;458:125-31.
- [3] Foschini MP, Flamminio F, Miglio R, et al. The impact of large sections on the study of in situ and invasive duct carcinoma of the breast. *HUM PATHOL* 2007;38:1736-43.
- [4] Morandi L, Marucci G, Foschini MP, et al. Genetic similarities and differences between lobular in situ neoplasia (LN) and invasive lobular carcinoma of the breast. *Virchows Arch* 2006;449:14-23.
- [5] Going JJ, Moffat DF. Escaping from flatland: clinical and biological aspects of human mammary duct anatomy in three dimensions. *J Pathol* 2004;203:538-44.
- [6] Tot T. DCIS, cytokeratins, and the theory of the sick lobe. *Virchows Arch* 2005;447:1-8.
- [7] Wellings SR, Jensen HM. On the origin and progression of ductal carcinoma in the human breast. *J Natl Cancer Inst* 1973;50:1111-8.
- [8] Tot T. The diffuse type of invasive lobular carcinoma of the breast: morphology and prognosis. *Virchows Arch* 2003;443:718-24.
- [9] Foschini MP, Righi A, Cucchi MC, et al. The impact of large sections and 3D technique on the study of lobular in situ and invasive carcinoma of the breast. *Virchows Arch* 2006;448:256-61.
- [10] Tot T, Gere M, Pekar G, et al. Breast cancer multifocality, disease extent, and survival. *HUM PATHOL* 2011;42:1761-9.
- [11] Lakhani SR, Ellis IO, Schnitt SJ, Tan PH, Van De Vijver MJ, editors. *WHO Classification of Tumours of the Breast*. 4th ed. Lyon: IARC Press; 2012.
- [12] Page DL, Rogers LW, Schuyler PA, Dupont WD, Jensen RA. The natural history of ductal carcinoma in situ of the breast. In: Silverstein MJ, editor. *Ductal carcinoma in situ of the breast*. 2nd ed. Philadelphia: Lippincott; 2002. p. 17-21.
- [13] Kimura M. A simple method for estimating evolutionary rate of base substitution through comparative studies of nucleotide sequences. *J Mol Evol* 1980;16:111-6.
- [14] Tavassoli FA, Eusebi V. *Tumors of the breast*. 4 ed. Washington, DC: American Registry of Pathology/AFIP; 2009.
- [15] Elston CW, Ellis IO. Pathological prognostic factors in breast cancer. 1. The value of histological grade in breast cancer: experience from a large study with long-term follow-up. *Histopathology* 1991;19:403-10.
- [16] Tot T. Clinical relevance of the distribution of the lesions in 500 consecutive breast cancer cases documented in large format histologic sections. *Cancer* 2007;110:2551-60.
- [17] Anderson S, Bankier AT, Barrell BG, et al. Sequence and organization of the human mitochondrial genome. *Nature* 1981;290:457-65.
- [18] MITOWEB. MITOMAP: A Human Mitochondrial Genome Database. <http://www.mitomap.org/MITOMAP> Published 2012. Accessed 2012 May 10.
- [19] Rozen S, Skaletsky HJ. Primer3 on the WWW for general users and for biologist programmers. In: Krawetz S, Misener S, editors. *Bioinformatics Methods and Protocols: Methods in Molecular Biology*.

- Totowa, NJ: Humana Press; 2000. p. 365-86. <http://sourceforge.net/projects/primer3/>.
- [20] Woischnik M, Moraes CT. Pattern of organization of human mitochondrial pseudogenes in the nuclear genome. *Genome Res* 2002;12:885-93.
- [21] Kumar S, Gadagkar SR. Efficiency of the neighbor-joining method in reconstructing deep and shallow evolutionary relationships in large phylogenies. *J Mol Evol* 2000;51:544-53.
- [22] Saitou N, Nei M. The neighbor joining method: a new method to reconstructing phylogenetic trees. *Mol Biol Evol* 1987;4:406-25.
- [23] Tamura K, Dudley J, Nei M, Kumar S. MEGA4: Molecular Evolutionary Genetics Analysis (MEGA) software version 4.0. *Mol Biol Evol* 2007;24:1596-9.
- [24] Morandi L, Asioli S, Cavazza A, Pession A, Damiani S. Genetic relationship among atypical adenomatous hyperplasia, bronchioloalveolar carcinoma and adenocarcinoma of the lung. *Lung Cancer* 2007;56:35-42.
- [25] Foschini MP, Morandi L, Marchetti C, et al. Cancerization of cutaneous flap reconstruction for oral squamous cell carcinoma: report of three cases studied with the mtDNA D-loop sequence analysis. *Histopathology* 2011;58:361-7.
- [26] Morandi L, Pession A, Marucci G, et al. Intraepidermal cells of Paget's carcinoma of the breast can be genetically different from those of the underlying carcinoma. *HUM PATHOL* 2003;34:1321-30.
- [27] Carrel L, Willard HF. X-inactivation profile reveals extensive variability in X-linked gene expression in females. *Nature* 2005;434:400-4.
- [28] Salk JJ, Horwitz MS. Passenger mutations as a marker of clonal cell lineages in emerging neoplasia. *Semin Cancer Biol* 2010;20:294-303.
- [29] Pai SI, Westra WH. Molecular pathology of head and neck cancer: implications for diagnosis, prognosis, and treatment. *Ann Rev Pathol* 2009;4:49-70.
- [30] Dworkin AM, Huang TH, Toland AE. Epigenetic alterations in the breast: implications for breast cancer detection, prognosis and treatment. *Semin Cancer Biol* 2009;19:165-71.
- [31] Slaughter DP, Southwick HW, Smeejkal W. Field cancerization in oral stratified squamous epithelium; clinical implications of multicentric origin. *Cancer* 1953;6:963-8.
- [32] Ha PK, Califano JA. The molecular biology of mucosal field cancerization of the head and neck. *Crit Rev Oral Biol Med* 2003;14:363-9.
- [33] Hitt R, Echarri MJ. Molecular biology in head and neck cancer. *Clin Transl Oncol* 2006;8:776-9.
- [34] Leemans CR, Braakhuis BJ, Brakenhoff RH. The molecular biology of head and neck cancer. *Nat Rev Cancer* 2011;11:9-22.
- [35] Volante M, Sapino A, Croce S, Bussolati G. Heterogeneous versus homogeneous genetic nature of multiple foci of in situ carcinoma of the breast. *HUM PATHOL* 2003;34:1163-9.
- [36] Aulmann S, Penzel R, Longerich T, Funke B, Schirmacher P, Sinn HP. Clonality of lobular carcinoma in situ (LCIS) and metachronous invasive breast cancer. *Breast Cancer Res Treat* 2008;107:331-5.
- [37] Heaphy CM, Griffith JK, Bisoffi M. Mammary field cancerization: molecular evidence and clinical importance. *Breast Cancer Res Treat* 2009;118:229-39.