



SHC 2013, International Conference on Solar Heating and Cooling for Buildings and Industry  
September 23-25, 2013, Freiburg, Germany

## Innovative compact solar air conditioner based on fixed and cooled adsorption beds and wet heat exchangers

Pietro Finocchiaro, Marco Beccali

*DEIM - Università degli Studi di Palermo, Via delle Scienze bld. 9, 90128, Palermo, Italy*

---

### Abstract

In this work, a new all-in-one compact solar air conditioner concept is presented. The system is mainly based on a new DEC process which utilises fixed and cooled adsorption beds operating in a batch process and two wet heat exchangers. The proposed innovative adsorption bed is a fin and tube heat exchanger commonly used in the air conditioning sector, wherein the spaces between the fins are filled with silica gel grains. The main feature of this component is to allow simultaneous dehumidification and cooling of air. Furthermore, since the component hosts a considerable amount of adsorption material, solar energy can be efficiently stored in the desiccant media in terms of accumulated adsorption capacity. This potential can be used when regeneration heat is not available, strongly reducing the need for thermal storage in the solar loop. The indirect evaporative cooling process, operated downstream to the dehumidification, is realized by two wet plate heat exchangers connected in series. The process can be operated at relatively low temperature, allowing supply air temperature to the room of about 20°C. A prototype of the compact solar air conditioner specifically developed for residential application is presented. The main features of the system as well as the thermodynamic cycle are first described. Monitoring results are presented by means of most commonly used performance indicators showing several advantages which can be obtained using the proposed solution.

© 2014 The Authors. Published by Elsevier Ltd.

Selection and peer review by the scientific conference committee of SHC 2013 under responsibility of PSE AG

*Keywords:* All-in-one compact solar air conditioner, DEC, Adsorption fixed and cooled bed;

---

### 1. Introduction

Nowadays DEC systems are present on the market only for medium scale air conditioning applications. This is due to the fact that the concept on which large DEC units are based is not suitable for small applications in terms of costs, space and typical restrictions related to the installation of a centralized air system.

In common DEC systems, desiccant rotors are normally used. However, the adsorption process realized by means of desiccant rotors presents the disadvantage of causing a temperature increase of the desiccant material. This phenomena is caused by the release to the process air of adsorption heat due to water condensation in the desiccant material and by the carry-over of heat stored in the desiccant material from the regeneration section to the process section. Moreover, desiccant rotor technology doesn't present the opportunity to store adsorption capacity into the desiccant material since adsorption rotors are generally built to host a relatively low mass of adsorbent. Therefore, the only option for energy storage can be related to the driving fluid, i.e. water heated by a solar plant. In addition, the use of hot air as regeneration fluid is suitable only with systems without storage.

The solution presented in this work was properly designed for residential application with the aim to overcome the mentioned limits typical of common DEC units.

### Nomenclature

ADS	Adsorption	MR	Mass ratio [-]
EER	Energy Efficiency Ratio [-]	Rad	Solar radiation [ $\text{W}/\text{m}^2$ ]
h	Specific Enthalpy [ $\text{kJ}/\text{kg}^\circ\text{C}$ ]	T	Temperature [ $^\circ\text{C}$ ]
HX	Heat Exchanger	x	Humidity ratio [ $\text{g}/\text{kg}$ ]

## 2. Description of the system

An innovative patented compact solar air conditioner designed for ventilation, dehumidification and cooling (heating in winter is also possible) is presented. The system is mostly designed for air conditioning of under - roof spaces and can be configured to be installed both on flat and sloped roofs. The system is basically composed by a casing which comprises a solar air collector, two adsorption beds, an integrated cooling tower, two plate wet heat exchangers, fans and all other auxiliaries needed to realize the air handling process.

The system is mainly based on the use of two fixed packed desiccant beds of silica gel, operating in a batch process, and two wet evaporative heat exchangers connected in series. The adsorption bed is a fin and tube heat exchanger, commonly used in several air conditioning applications wherein the spaces between the fins are filled with silica gel grains. Therefore, the adsorption material can be cooled by means of the water loop of heat exchanger which is in connection with an heat sink. In addition, the component can be seen as a latent energy storage since an high adsorption capacity can be accumulated into the desiccant material when solar radiation is available and used it later when cooling energy is needed.

A system of air dumpers provides the commutation between the two adsorption beds in order to guarantee a continuous dehumidification process. For a detailed description of the component and its performances, refer to [1].

A cooling tower which is integrated in the system is used to reject the adsorption heat generated in the desiccant bed operating in dehumidification mode. Regeneration is carried out using a solar air collector. The air flow rate passing the adsorption bed is about 40% of the one delivered to the conditioned space. Electricity is only due to the operation of three fans and two pumps. Cooling power can be controlled through variable speed fans. Fig. 1 shows the concept and the scheme of the system. The thermodynamic cycle and the concept of the process air is described in Fig. 2. A flow rate of outside air (1) is drawn through one of the adsorption beds for its dehumidification and partial cooling. Thanks to the simultaneous moisture and heat exchange, dehumidification process can indeed be carried out at almost constant temperature (2). Afterwards, dehumidified air is mixed with the return air from the building which is at conditions (6), reaching the conditions of point (3). The mixed air, which has a flow rate equal to 140% of the air flow rate supplied to the building, enters the wet heat exchangers reaching the supply conditions at point (4).

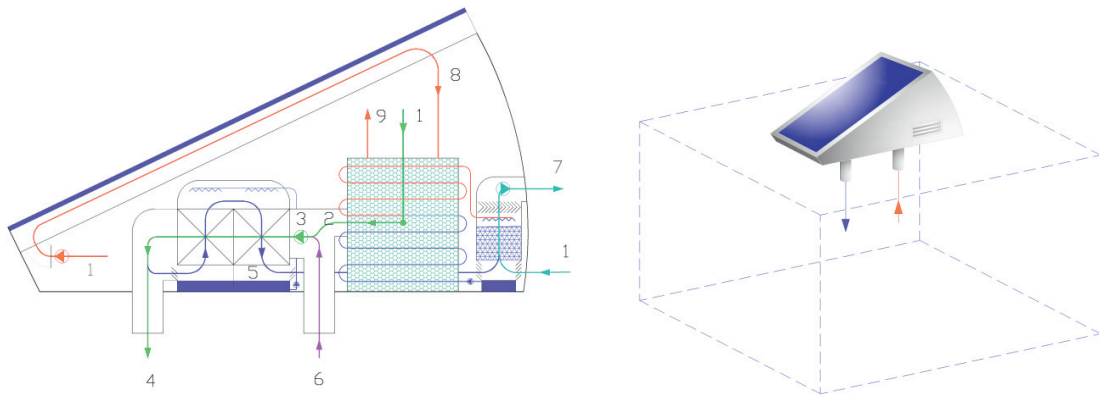

Fig. 1. Solar air conditioner: scheme of the system (left) and building integration concept (right)

In order to produce the cooling effect, at the outlet of the second wet heat exchanger, a portion of the air flow rate equal to 40% is drawn on the secondary side. The heat released in the adsorption bed is rejected to a water loop which is connected to the cooling tower integrated in the system. The air flowing through the cooling tower comes from the secondary side of the wet heat exchanger or optionally from outside. In this last case, which is considered in Fig. 2, the additional fan for the cooling tower is needed.

	Description	x	T	H
	-	g/kg	°C	kJ/kg
Process air	1 Outside air	16.0	36.0	77.2
	2 Adsorption bed	6.0	34.0	49.5
	3 Mixing	9.6	28.3	52.8
	4 Wet HX1 + HX2	9.6	19.0	43.3
Building	6 Return air	11.0	26.0	54.1
Secondary air in wet heat exchangers	4 Wet HX1 + HX2	9.6	19.0	43.3
	5 Humidification	10.8	17.0	44.4
Cooling tower	1 Inlet cooling	19.8	28.0	78.7
	7 Cooling tower	25.5	30.0	95.3
Regeneration air	1 Outside air	16.0	36.0	77.2
	8 Solar collector	16.0	60.0	102.0
	9 Desorption	24	40	101.96

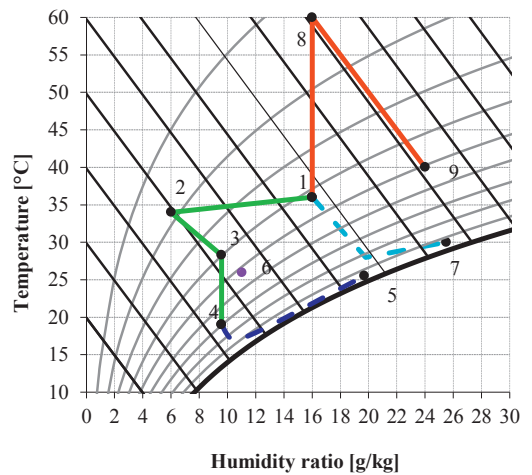

Fig. 2. Thermodynamic cycle on psychrometric chart

The control strategy of the system is the following. If there is no need for cooling, solar energy is used to regenerate the adsorption material of the desiccant beds. In particular, one bed is regenerated until the temperature difference between the outlet air of the solar collector and the air coming out from the bed is higher than a fixed threshold. If the difference is lower and the solar fan is at the minimum speed, the control system commutes to the other bed for its regeneration.

If the system has to provide cooling, the main fan is used to provide fresh and dehumidified air to the building. Building temperature and humidity can be controlled independently. Temperature can be adjusted controlling the speed of the main fan and by the status of the recirculation pump of the wet heat exchangers. Humidity can be controlled can be adjusted controlling the speed of the fan and the status of the pump of the cooling tower and partially controlling the speed of the main fan. A variation of the temperature of adsorption material will result into a different dehumidification capacity and consequently this property can be used to adjust the humidity in the

conditioned space. During the cooling operation, the control strategy which sets the operation of the two adsorption beds is based indeed on the humidity conditions of the return air. If the humidity set point is exceeded, then the control system activates the commutation procedure from one bed to the other. Before the end of this phase, which lasts 40 minutes, a pre-cooling of the bed which was operated in regeneration mode is carried out, preparing it for the next operation in adsorption mode.

### 3. Experimental results and discussion

In order to verify the proposed concept, a prototype was developed and monitoring results are here presented. The system has two adsorption beds, each containing about 15 kg of silica gel in grains with a gross volume of  $0.55 \times 0.6 \times 0.1 \text{ m}^3$ . The flow rate of the system delivered to the building is about  $500 \text{ m}^3/\text{h}$  whereas the maximum total cooling power is about 2,2 kW at standard summer conditions ( $T_{\text{outside}} = 35^\circ\text{C}$ ,  $\text{RH}_{\text{outside}} = 50\%$ ,  $T_{\text{bui}} = 27^\circ\text{C}$ ,  $\text{RH}_{\text{bui}} = 50\%$ ). The cooling power delivered to the building calculated as enthalpy difference between return and supply air is indeed about 1 kW. It is worth to be noted that in the system only one wet heat exchanger is used. Maximum electric power required is approximately 200 W and is due to the operation of two DC variable speed fans (no cooling tower fan is used) and two DC pumps.



Fig. 3. Picture of the prototype of the solar air conditioner

For the monitoring of the system, five HIH – 4000 series Honeywell humidity sensors with accuracy  $\pm 3,5\%$  were used and nine precision integrated-circuit temperature sensors, type LM35CAZ by National Semiconductor, accuracy of  $\pm 0,5^\circ\text{C}$ , positioned upstream and downstream of the main components. Flow rate were measured using an anemometer with a accuracy of  $\pm 3 \%$  over the full scale. Solar radiation was measured using a pyranometer (1st class, ISO 9060) installed on the collector plane. Electricity consumption was measured using a DC meter with  $\pm 0,5\%$  accuracy. A Microprocessor Arduino Mega 6025 in combination with Labview was used as control and acquisition unit.

Main energy performance indicators used in the following evaluation of monitoring data are listed below:

$$MR = \frac{\dot{m}_{\text{outside}}}{(\dot{m}_{\text{supply}} + \dot{m}_{\text{outside}})} \quad (1)$$

$$\text{Cooling energy}_{\text{ADS BED}} = \dot{m}_{\text{outside}} (h_1 - h_2) \quad (2)$$

$$\text{Cooling energy}_{\text{WET HX}} = (\dot{m}_{\text{outside}} + \dot{m}_{\text{supply}})(h_3 - h_4) \quad (3)$$

$$\text{Total cooling energy delivered} = [\dot{m}_{\text{outside}} (h_1 - h_2) + (\dot{m}_{\text{outside}} + \dot{m}_{\text{supply}})(h_3 - h_4)] (1 - MR) \quad (4)$$

$$EER = \frac{\text{Total cooling energy delivered}}{\text{Total electricity consumed}} \quad (5)$$

$$COP_{th} = \frac{\text{Total cooling energy delivered}}{\text{Solar Heat delivered}} \quad (6)$$

First tests aimed to the verification of the control and monitoring system and to the tuning of components started in June of this year. After the this first phase, a the real monitoring was performed. Globally about 30 days of monitoring data are available with a total amount of 240 operation hours. With the aim to proof the proposed concept, a selection of one week operation data is presented here below.

In Fig. 4 a view into the dehumidification performances of the system is given for a selected day. System is started at 10:00 am and stopped at 6:00 pm. The commutation between one bed to the other is represented with the ON/OFF of the variable Valve. At the beginning of the day, the system starts operating in adsorption mode the same bed used the day before (Valve=1). Since the desired humidity ratio in the room cannot be reached, at 10:30 am the control strategy commutes to the other bed (Valve=0) remaining in this mode for about 2 hours when a new change in the beds operation mode occurs. It can be noted that in the second half of the day, since less solar radiation is available, the commutation periods become smaller, but globally the humidity in the room can be controlled quite well.

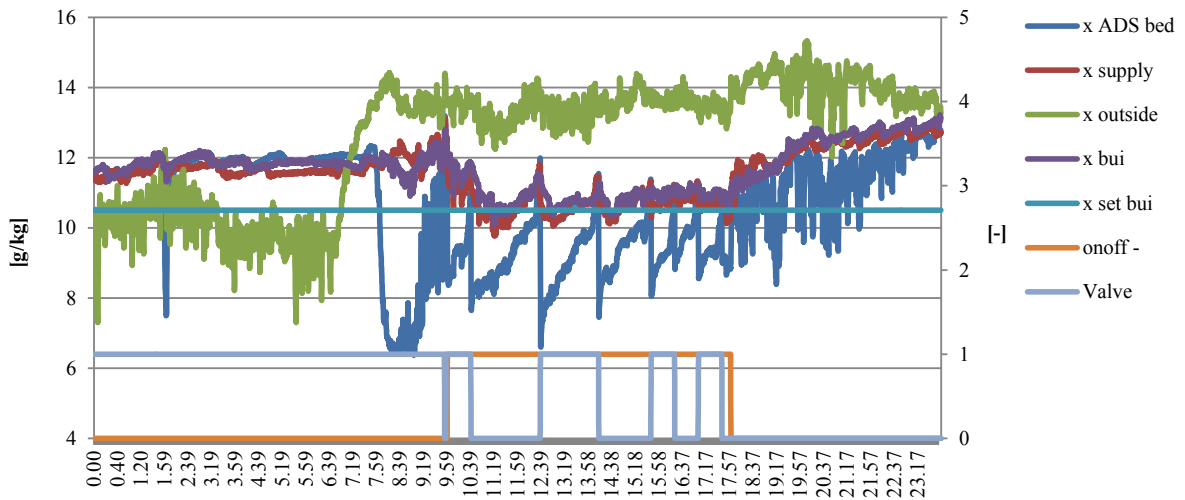

Fig. 4. Humidity ratio values for the 5<sup>th</sup> day of the selected week

In Fig. 5 performances in terms of supply temperature and temperature inside the building are shown. Supply temperature ranges around 22,5°C until 3:00 pm when the pump of the wet heat exchanger starts to make cycles of switching on and off in order to control the temperature in the room. At that time, since the need of cooling becomes lower, cooling power is also reduced controlling the flow rate of the main fan. In the same figure it can be noted that, when the wet heat exchanger pump is on, temperature difference across the wet heat exchanger is about 5 °C. This value corresponds to an efficiency of the wet heat exchanger of about 45-48%. Such relatively low efficiency values are due to the fact that the flow rate mass ratio between secondary and primary side of the heat exchanger is only 0,28.

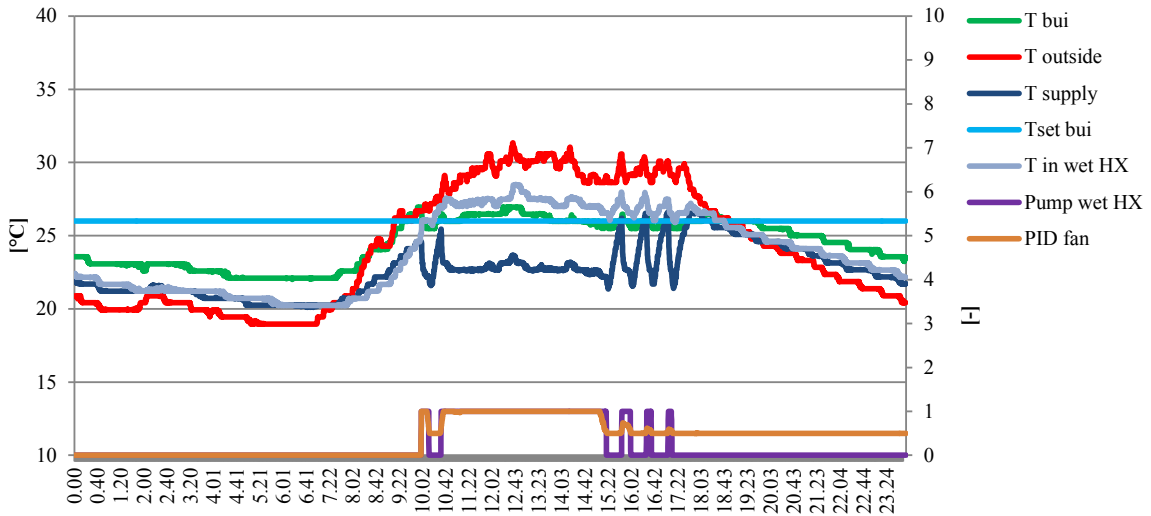

Fig. 5. Temperature values for the 5<sup>th</sup> day of the selected week

In Fig. 6 the outlet temperature of the solar collector together with the outlet temperature from the adsorption bed is reported. Regeneration temperature ranges between 40°C and 60°C. Temperatures of the air coming out from the adsorption bed are slightly higher than of outside air ones, after the commutation between the beds occurs. It is worth to be noted that these values are considerably lower than the ones commonly registered in desiccant rotor based systems.

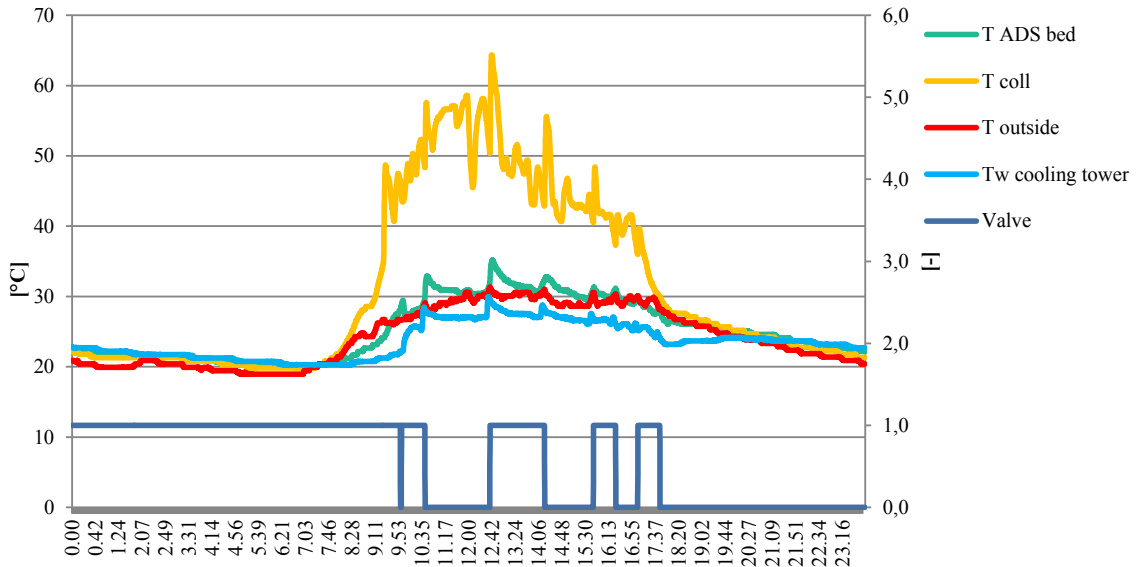

Fig. 6. Temperature values for the 5<sup>th</sup> day of the selected week – Solar, ADS bed and cooling tower

Finally the total cooling and electric power are presented in Fig. 7, as well the EER and the thermal COP. The EER values range from 5 to 10 for the day considered day. The daily average value of the EER is 5,95 whereas the

thermal COP is 1,21. For the examined day of operation, 38% of the cooling power is related to the enthalpy difference in the adsorption bed, whereas the 62% is due to the wet heat exchanger.

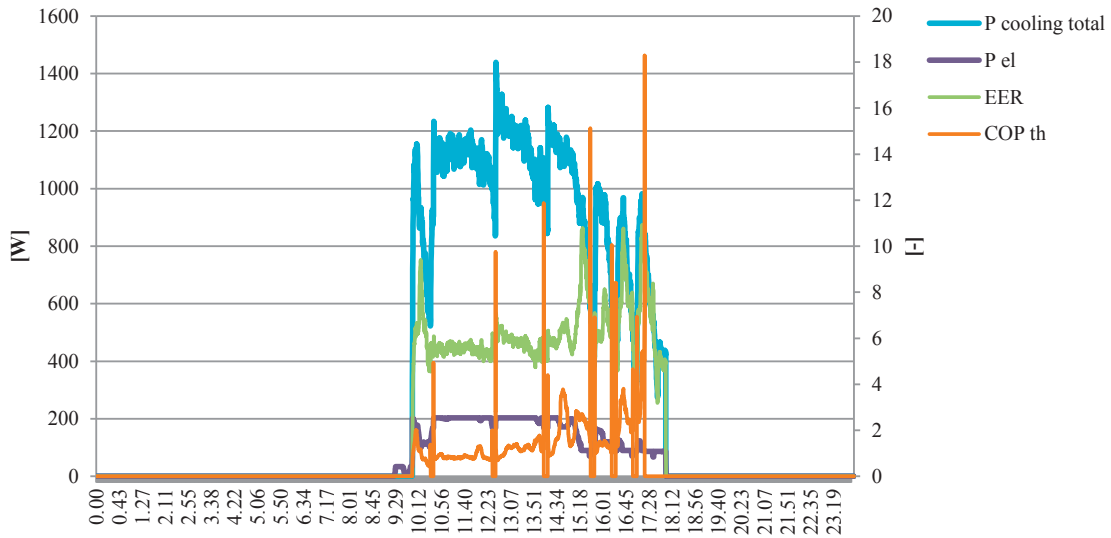

Fig. 7. Energy performances for the 5th day of the selected week

In the following figure, the distribution of the electricity consumed by the auxiliaries is shown. As one can see the main portion of the consumption is due to the main fan which is responsible for 62% of the total consumption amounting to 1,29 kWh.

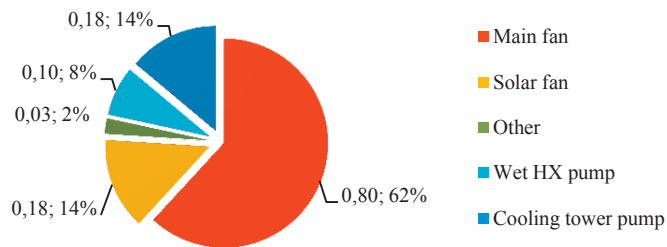

Fig. 8. Electricity consumptions distribution for the 5th day of the selected week

As already mentioned, an important feature of the system is the possibility to store adsorption capacity in the beds which therefore can be used as latent storages. In order to show this behavior, another day of operation is presented. In this day the system is switched on at 2:00 pm and stopped at 10:00 pm (see Fig.8). During the morning, solar heat was used to regenerate one desiccant bed (Valve=1), no other operation was carried out. As the system started, the bed which was working before in regeneration mode and is now working in adsorption mode providing dehumidification with a humidity ratio difference between inlet and outlet of about 7 g/kg.

As clearly shown by the humidity values registered at the outlet of the beds, the system could provide dehumidification for several hours after the sunset using only one bed. Since in DEC systems the cooling process depends on the dehumidification carried out, cooling of the building can be also guaranteed.

Since the humidity set point value is not reached, the control strategy commutes from one bed to the other after the mentioned waiting time is gone.

The swinging of the humidity measured at outlet of the adsorbing bed is due to the fact that the other bed could not be regenerated during the morning so the two adsorption capacity are very different. It's also to be considered that, after 2:00 pm, the other bed could not be properly regenerated, since regeneration temperatures were low, in the range of 40 °C.

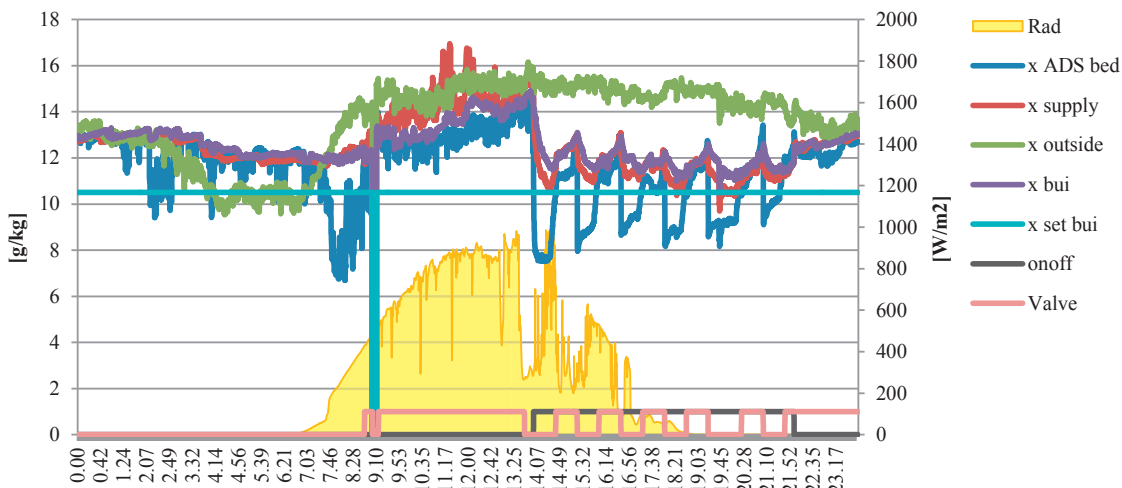

Fig. 9. Humidity ratio values for the 6th day of the selected week

For the selected week, performance data are summarized in the following figures. On the left side of the Fig. 10 the daily efficiency values of the solar collector are shown. As one can observe, the values are quite high ranging from 57% to 78%. Such high values are due to the fact the solar collector is working at low temperature, taking outside air at the inlet.

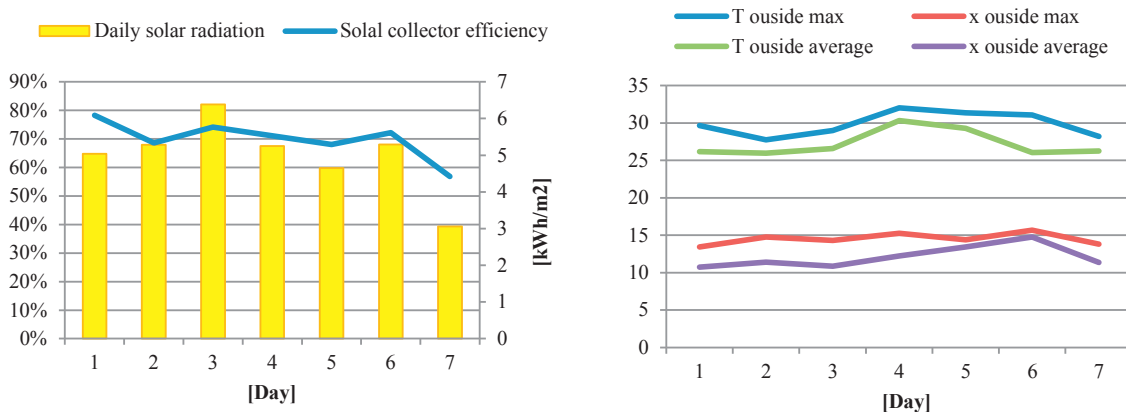

Fig. 10. Daily weather conditions and solar collector efficiency for the selected week of operation

In Fig. 11 other energy performances indicators are reported. Daily EER values range between 3,3 and 6 with an average value of 4,8. The lower values of EER are especially due to the limited temperature difference between return and supply air. This is related also to the use of one heat exchanger instead of two in series.



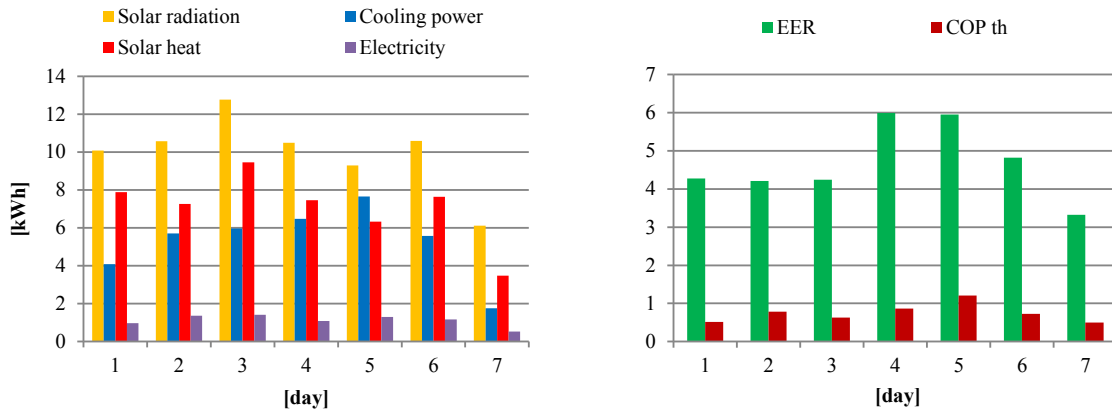

Fig. 11. Daily weather conditions and performance indicators for the selected week of operation

#### 4. Conclusions

In this work, an innovative compact desiccant cooling system for small scale applications is presented. The core component is a new desiccant bed consisting in a ordinary finned and tube air-water heat exchanger with air gaps between the fins filled with silica-gel grains. This component allows simultaneous mass and heat transfer, permitting to dehumidify and cool the processed air. In addition, the proposed solution permits also to regenerate the desiccant material operating at low temperature (max 60°C) using a standard solar flat plate air collector.

In order to test the proposed concept, a prototype was developed and monitored. Results show the validity of the proposed solution and good performances both in terms of building temperature and humidity control. EER and thermal COP values are also encouraging, but optimizations are still possible. Cooling power delivered to the building could be easily increased by the use of two wet heat exchangers connected in series instead of only one. Electricity consumptions could be further reduced by a redesign of the air channels.

In relation to the desiccant beds, the opportunity to provide dehumidification and cooling also several hours after the sunset and to control the dehumidification process acting on the temperature of the bed have been shown. Furthermore, the fact that adsorption and desorption processes happen in different times can be considered an advantage for the control of the dehumidification process.

Further works will be carried out on the concept in order to increase the global energy performances.

#### References

- [1] Finocchiaro P., Beccali M., Gentile V. "Experimental investigation of adsorption performances of an heat exchanger packed with silica gel for application in solar desiccant cooling systems" 5th International Conference on Solar Air-Conditioning OTTI 2013 Sept 2013