

# Accepted Manuscript

Towards self-diagnosis composites: Detection of moisture diffusion through epoxy by embedded evanescent wave optical fibre sensors

Cristian Marro Bellot, Massimo Olivero, Marco Sangermano, Milena Salvo

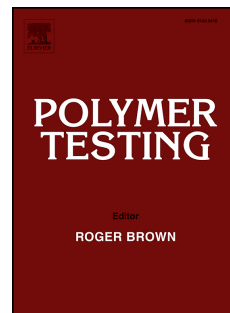

PII: S0142-9418(18)31006-7

DOI: [10.1016/j.polymertesting.2018.09.019](https://doi.org/10.1016/j.polymertesting.2018.09.019)

Reference: POTE 5617

To appear in: *Polymer Testing*

Received Date: 26 June 2018

Revised Date: 10 September 2018

Accepted Date: 12 September 2018

Please cite this article as: C. Marro Bellot, M. Olivero, M. Sangermano, M. Salvo, Towards self-diagnosis composites: Detection of moisture diffusion through epoxy by embedded evanescent wave optical fibre sensors, *Polymer Testing* (2018), doi: <https://doi.org/10.1016/j.polymertesting.2018.09.019>.

This is a PDF file of an unedited manuscript that has been accepted for publication. As a service to our customers we are providing this early version of the manuscript. The manuscript will undergo copyediting, typesetting, and review of the resulting proof before it is published in its final form. Please note that during the production process errors may be discovered which could affect the content, and all legal disclaimers that apply to the journal pertain.

# TOWARDS SELF-DIAGNOSIS COMPOSITES: DETECTION OF MOISTURE DIFFUSION THROUGH EPOXY BY EMBEDDED EVANESCENT WAVE OPTICAL FIBRE SENSORS

CRISTIAN MARRO BELLOT<sup>1</sup>, MASSIMO OLIVERO<sup>2</sup>, MARCO SANGERMANO<sup>1\*</sup>, MILENA SALVO<sup>1\*</sup>

<sup>1</sup>*Politecnico di Torino, Dipartimento di Scienza APplicata e Tecnologia, C.so duca degli Abruzzi 24, 10129, Torino, Italy*

<sup>2</sup>*Politecnico di Torino, Dipartimento di Elettronica e Telecomunicazioni, C.so duca degli Abruzzi 24, 10129, Torino, Italy*

\*[milena.salvo@polito.it](mailto:milena.salvo@polito.it), [marco.sangermano@polito.it](mailto:marco.sangermano@polito.it)

## Abstract

This paper reports on an epoxy matrix for glass fibre reinforced polymers equipped with low cost optical fibre sensors for the early detection of water diffusion, with devised applications in the oil and gas industry. Novel evanescent wave optical fibre sensors were designed, fabricated and embedded in epoxy resin samples. The tips of the optical fibre sensors were coated with a silver layer to work in reflection, so that they could be used as probes. Accelerated diffusion tests were performed: the samples were exposed to simulated sea water at 80 °C for up to 148 hours. The water diffusion resulted in a remarkable change of the reflected signal from the sensors, a result that was then confirmed through gravimetric measurements and a theoretical prediction, according to Fick's diffusion law. The results corroborate the feasibility of "sensitive" fibre reinforced polymers in harsh environments and that chemicals diffusion in these materials can be remotely and continuously monitored by means of the presented sensing system.

*Keywords* Optical fibre sensors; Polymer composites; Structural health monitoring; Moisture diffusion.

## 1. Introduction

Glass Fibre Reinforced Polymers (GFRPs), being light and corrosion-resistant, are a key candidate for application in the harsh environments found in the aerospace, marine and oil and gas industries [1]. These materials are used extensively in oil pipes, as they are less expensive than steel pipes, due to their lower processing temperatures and material costs. GFRPs represent a viable alternative to steel or corrosion resistant alloys, but there is still a lack of information on their degradation rates and degree of cracking as well as a lack of risk analysis. GFRP pipes and components may be subjected to severe environmental conditions, in terms of temperature, pressure and fluid exposure [2]. The diffusion of sea water and moisture through the composite thickness represents a challenging technological issue [3] [4] that should be tackled at its early stage, in order to prevent long-term damage and expensive replacement strategies. The early stage detection of water diffusion should be accomplished by a continuous-monitoring system with some specific features: remote operation, safety, minimum invasiveness and low cost.

In the oil and gas industry, conventional electric-based sensors may suffer from remarkable limitations, in terms of remote operation and embedding. For instance, water absorption of a GFRP pipe could be monitored by measuring the resistivity of the GFRP with low cost integrated circuits [5], but their digital output would need to be readable within a few tens of cm, which in turn would limit remote operation. Moreover, embedded ~1 mm diameter electric probes could affect the mechanical properties of the polymer matrix. An extended version of the resistivity measurement is the electrical impedance spectroscopy, which has recently been investigated as a tool for monitoring the moisture diffusion in GFRPs [6]. However, the limited capability of remote interrogation and electric-related issues are limiting factors that could be overcome using optical fibre sensors.

The problem of continuous monitoring of the ageing/degradation of GFRPs not only occurs in real situations, it is also a challenging issue for companies that perform material testing. They normally run the tests (e.g. diffusion of chemicals, pressure/thermal tests etc.) in dedicated machines, where access to the sample is not allowed, and changes in the material characteristics can only be detected through subsequent inspections and testing [7]. In these cases, it would be advisable to endow the sample with sensors that could be interrogated:

- remotely,
- in real-time,
- without the need of power supply, visual or wireless access,
- reliably, to withstand the environmental conditions of the test.

Optical fibres have been employed extensively in sensing applications, because of their immunity to radiofrequency interferences and their intrinsic fire safety properties. Bare optical fibre sensors can be embedded in a GFRP item without degrading its mechanical characteristics [8]. Furthermore, they can be interrogated from over the range of some kilometres or more. The scientific community has presented several applications where optical fibre sensors have been used to monitor physical and chemical quantities

in polymer composites, e.g. [9]. Most of them are based on the well-established fibre Bragg grating technology, although some alternative solutions have been tested and compared [10]. As an example, plastic optical fibre sensors described in [11], have similar characteristics and potential to the sensors hereby presented. However, standard plastic optical fibres have larger diameters, hence they partially meet the minimum invasiveness requirement. Moreover, the mechanical and thermal properties of these fibres may not be compatible with the embedding process in GFRPs (mainly because of thermal constraints). Finally, their higher optical attenuation, compared to glass optical fibres, reduces the remote operation. Optical fibre sensors based on "side polishing" [12] are fragile and difficult to embed, mainly because of their two-termination configuration. Moreover, they were not suitable for epoxy resin, since the latter has a refractive index of 1.5511 at 1550 nm, whereas the side-polished sensors are able to work with indexes of around 1.47. L. Wang et al. [13] monitored the cross-linking reaction during GFRPs fabrication, where the E-glass fibres that constitute the composite were directly used as a light transmission bundle and sensor.

Based on the previous analysis, this work reports on the design and experimental test of new, low cost optical fibre sensors for the monitoring of the diffusion of sea water and degradation through the thickness of an epoxy resin used to fabricate GFRPs, with the aim of realizing a turnkey monitoring system for polymeric and composite structures. The sensors were made by depleting the cladding of a commercial optical fibre for telecommunications, in order to make it sensitive to the surrounding environment. These sensors are commonly defined evanescent wave optical sensor (EWOS), since they rely upon the light "leaking" from the fibre that interacts with the surrounding material. This work follows a previous research by the same authors [14], in which the diffusion of water was probed by recording the spectral attenuation of the fibre sensors. The sensing system has been here improved by introducing single-ended fibre probes that exhibit a single termination, thus making the embedding easier, reducing the structural perturbation of the artefact and reducing the probability of breakage at the optical fibre-polymer interface. Furthermore, the sensors were interrogated with a benchtop low-cost spectrometer working in the near infrared spectrum, rather than using complex instruments such as a Fourier Transform Infrared spectrometre (FTIR)] . Furthermore, the whole monitoring system has been developed to enable long-term operation and continuous reading of several sensors.

In summary, this work aims at providing a turnkey solution to the monitoring of water diffusion in polymers and GFRPs, by proposing a process that includes the fabrication of low cost optical fibre sensors based on evanescent wave sensing and working in reflection and a detection system relying on near-infrared spectroscopy with a custom-developed system for remote and long-term operation.

The paper is organized in two sections; the first presents the materials and methods used to realize and characterize the epoxy resin samples and the optical fibre sensors (sect. 2- Materials and methods) and the second part reports and discusses the quantitative results on detection of water diffusion (sect. 3 - Results and discussion).

## 2. Materials and methods

The workflow of this research was split into two lines, namely

- the development of samples made of epoxy resin that could accurately simulate the characteristics of GRFPs, in terms of sea water diffusion;
- the development of optical fibre sensors, based on evanescent field sensing, that could work in reflection mode.

The two tasks were then merged by developing a suitable technique to embed multiple sensors that could detect water diffusion through the thickness of the samples.

### 2.1 Epoxy, preparation and characterization

The epoxy resin selected for this project was Ampreg 26 (Gurit, Switzerland), as it is particularly suitable for manufacturing large and high-performance composite structures. The resin was crosslinked with the provided Ampreg 26 slow hardener, in a 100:33 weight ratio, according to the indication in the technical sheets. Samples were prepared with dimensions of  $100 \times 20 \times 5$  mm.

The best curing conditions for this resin were evaluated by means of Differential Scanning Calorimetry (DSC), (Metler Toledo, Stare system DSC 1) and Fourier-Transform Infrared spectroscopy (FTIR) (Thermo Scientific Nicolet 5700), in attenuated total reflectance mode, from  $500$  to  $4000$   $\text{cm}^{-1}$  ( $2.5$  to  $20$   $\mu\text{m}$  in terms of wavelength). The crosslinked materials were characterized by means of Dynamic Mechanical Analysis (DMA) (Tryton Technology).

The resin was crosslinked according to the following procedure: 1) degassing of the reagents (epoxy and amine crosslinker) at room temperature and 2) mixing (both steps performed under vacuum); 3) pouring the mixture into a silicone mould in air; 4) leaving the mixture at room temperature for 24 h in air and, finally, 5) thermal curing at  $80^\circ\text{C}$  for 5 h in a muffle furnace. The final curing temperature was assessed by means of DSC, FT-IR and DMTA analysis.

The coefficient of moisture diffusion into the crosslinked epoxy was measured by exposing 16 specimens to simulated sea water [15] at  $80^\circ\text{C}$  (full immersion) and performing gravimetric measurements until saturation was reached.

### 2.2 Fabrication of the optical fibre sensors

The sensors were produced by chemically etching the initial  $125$   $\mu\text{m}$  diameter of a standard glass optical fibre (GIF 625 silica multimode fibre, Thorlabs) down to  $50$   $\mu\text{m}$ , in order to expose the core, where the light is confined, to the surrounding environment [16]. The chemical etching was performed by lowering the mechanically uncoated section (either 2, 6, 8, 10 or 14 cm) into  $>40$  % hydrofluoric acid (HF) (Sigma Aldrich) at room temperature and leaving it there for 32 minutes. The fibres were cleaved, with a diamond-blade cleaver, to obtain a smooth surface of the fibre tip. A mirror was then applied to the cleaved termination. And this allowed the sensor to work in reflection mode as an embedded probe. The mirror was

made by chemically depositing a silver coating, by means of Tollen's reagent. The latter consists of a solution of silver nitrate and ammonia which, with a proper procedure, precipitates silver onto an exposed glass surface [17], [18].

The sensitive section of some sensors was sputtered with copper, to annihilate their sensitivity to the surrounding environment. These "dummy" sensors (referred to as Cu-OFS) were prepared by depositing a copper coating on the bare core by means of Radio Frequency magnetron sputtering (Microcoat). The purpose of using the dummy sensors was to prove that the information provided by the OFSs was not related to spurious phenomena (source fluctuation, mechanical stress, etc.).

### 2.3 Sensor embedding

The fibre sensors were embedded while pouring the resin into an  $850 \times 1050 \times 100$  mm inner dimension silicone mould, according to the curing process described in 2.1. Figure 1 shows a sketch of an epoxy sample with embedded optical fibre sensors at different depths, along with a picture of a sample. Four samples were fabricated, each embedding 3 sensing fibres, and data was therefore acquired from a total of 12 sensors. A 40 mm long thermally-shrinking protection sleeve was used to protect the insertion of the fibre into the epoxy.

Cross-sections of polished epoxy samples, containing multiple embedded OFSs, were characterized by scanning electron microscopy (Philips 525 M SW9100 EDAX).

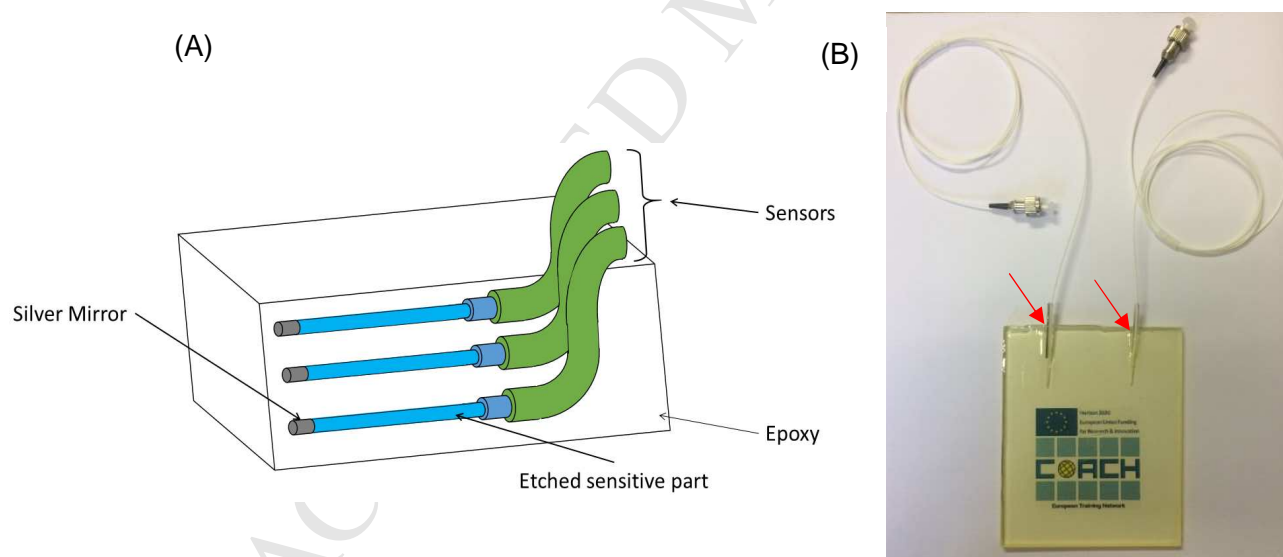

*Figure 1. A) Schematic of an epoxy sample with multiple optical fibre sensors (OFSs) with silver (Ag) coated tips embedded at different depths. B) Snapshot of a sample with two embedded OFSs pigtailed to standard telecommunication connectors. The red arrows indicate the protective sleeves.*

## 2.4 Characterization of the samples equipped with optical fibre sensors

Samples containing multiple embedded fibre sensors were immersed in simulated sea water, at 80 °C, for up to 148 h. The sensors were interrogated with the setup depicted in Figure 2. The equipment is off-the shelf in the telecommunication industry and can be integrated in a self-standing measurement unit. The optical signal for the interrogation of the sensors is provided by a broadband source (Photonics 3626BT) which emits a total power of 25 mW over a 1500-1600 nm range. The optical signal is addressed to multiple sensors by means of a computer-controlled fibre optics switch (JDS Uniphase 2x16 SB series). The sensors are connected to the switch by movable connectors (Thorlabs BFT-1). Movable connectors were chosen as they are an easy-to-handle alternative to fusion-spliced pigtails, because they introduce negligible losses in this application and can easily be replaced by cheap field-installable connectors [19][20] in a manufacturing framework. A fibre optic coupler extracts the signal reflected from the sensor (which contains the sensing information) from the transmitted one. The reflected signal is processed and displayed by means of portable spectrometer (Avantes AvaSpec-NIR256-1.7), which is capable of measuring spectra over the 1100-1700 nm range with a 3 nm resolution [21]. The resolution of the spectrometer is adequate to the application discussed in this paper. The system was designed for automatic logging of spectra through a LabVIEW custom-developed programme. The spectra may be recorded with a selectable sampling rate. In general, most of the experiments were carried out by recording spectra every 5 minutes and they lasted from hours to days.

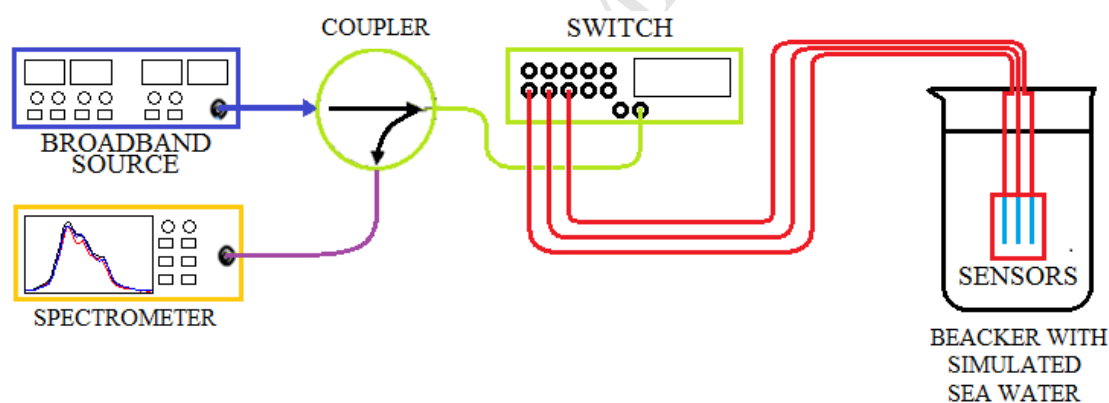

Figure 2. Schematic of the interrogation set up.

## 3. Results and discussion

### 3.1 Epoxy characterization

The crosslinking of the epoxy resin was evaluated by means of DSC and FT-IR analysis, in order to define the best curing conditions to obtain the best performing polymer, in terms of thermo-mechanical and viscoelastic properties.

The DSC-dynamic analyses were initially performed to evaluate the heat release for a complete epoxy group conversion [22]. The isothermal analyses were then performed at 60 °C, 80 °C and 100 °C, for either 3 or 5 hours. The conversion data are collected in Figure 3. When the temperature was increased, a higher epoxy

group conversion was achieved, since it was possible to delay the vitrification. Moreover, a longer curing time enhanced the epoxy group conversion.

The epoxy group conversion was also measured by means of FT-IR analysis at 60 °C, 80 °C and 100 °C, for either 3 or 5 hours. This epoxy group conversion was evaluated by considering the reduction in the peak centred at  $950\text{ cm}^{-1}$ . Table 2 shows the conversions values calculated by means of FT-IR analysis, which are in agreement with the values obtained from the DSC experiments [23], [24], [25].

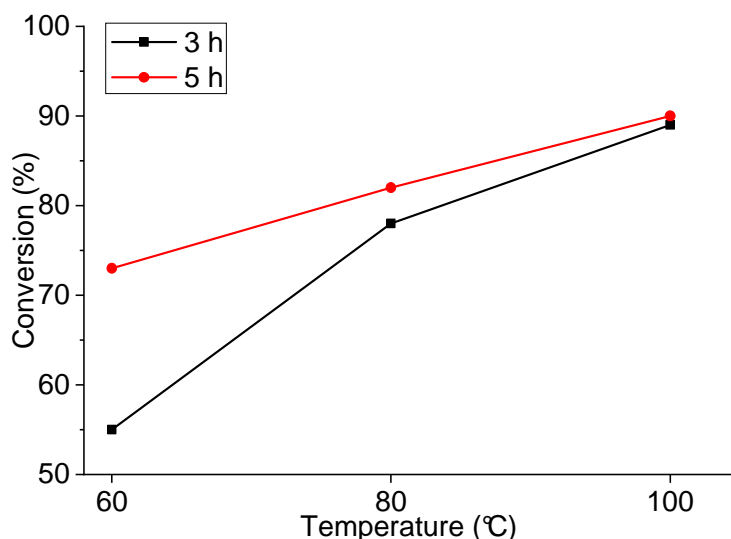

Figure 3. DSC results at 60 °C, 80 °C and 100 °C for 3 h and 5 h.

Table 2. FT-IR conversion results at 60 °C, 80 °C and 100 °C for 3 h and 5h.

Temperature (°C)	Conversion (%) for 3 h	Conversion (%) for 5 h
60	86±2	87±1
80	88±3	90±2
100	92±2	94±3

The viscoelastic properties of the crosslinked materials were evaluated by means of DMTA analysis. The glass transition temperature ( $T_g$ ) values were measured as the maximum of  $\tan\delta$  peak. The data are summarized in Table 2. As expected, by increasing the epoxy group conversion, it was possible to achieve much higher  $T_g$  values for the crosslinked materials, as a result of a higher crosslinking density. It is evident, from a comparison of the values obtained for the samples cured at 80 °C or at 100 °C for 5 hours, that  $T_g$  is not so different.



For this reason, the curing conditions of 5 hours at 80 °C were chosen, since these conditions allowed a good conversion and a sufficient high Tg of the crosslinked epoxy matrix to be achieved.

Table 2. DMTA data results at 60 °C, 80 °C and 100 °C for 3 h and 5h.

$T^a$ (°C)	$Tg_{3h}$ (°C)	$Tg_{5h}$ (°C)
60	88±3	90±2
80	94±5	108±3
100	108±2	110±3

The sea water diffusion was initially evaluated by means of a gravimetric measurement, after soaking the crosslinked specimens in simulated sea water at 80 °C; the saturation was achieved within 300 hours. Fig. 4 shows the weight gain versus time. The error bars represent the standard deviations of the gravimetric measurements that take into account both the uncertainty of the weight measurement and the reproducibility over different samples. The diffusion coefficient was calculated considering the process as a Fickian, through eq. 1 [26]

$$D = \pi \left( \frac{h}{4M_\infty} \right)^2 \left( \frac{M_2 - M_1}{\sqrt{t_2} - \sqrt{t_1}} \right)^2 \quad (1)$$

and resulted to be

$$(8.8 \pm 0.4) \times 10^{-12} \text{ m}^2/\text{s}.$$

where  $h$  is the sample thickness,  $M_\infty$  is the weight gain at saturation, expressed in percentage;  $M_1$  and  $M_2$  are two points on the linear section of the weight gain curve, expressed in percentage, while  $t_1$ ,  $t_2$  are the corresponding time spots in s

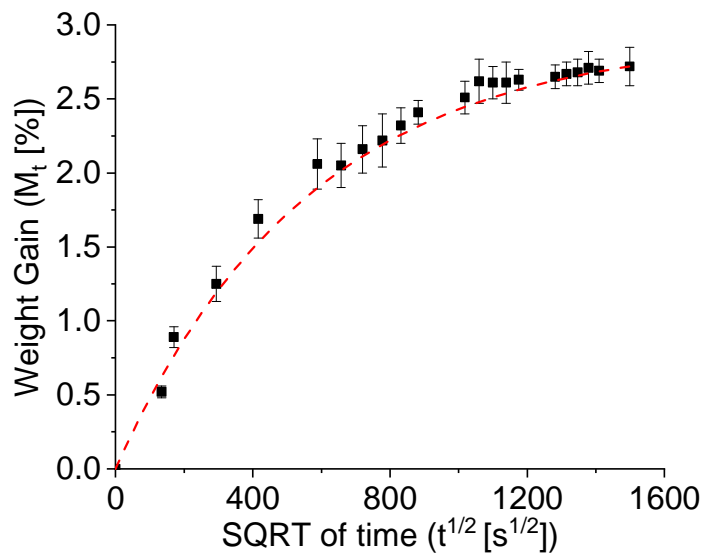

Figure 4. Weight increment of the epoxy immersed in simulated sea water for up to 700 h. The experimental data (black squares) are interpolated by the Fick approximate diffusion equation (red dashed curve).

### 3.2. Optimisation of the optical fibre sensors

The etched optical silica fibre acts as a sensor by leaking light into the epoxy resin. The attenuation of the light guided into the fibre changes because of a change in the refractive index and absorption of the epoxy around the exposed core. In order to optimize the sensitivity, sensors with different lengths of the chemically-etched section (2, 6, 8, 10 and 14 cm) were produced. Figure 5 shows the spectra reflected from the sensors manufactured with different sensing lengths, when they were characterized under the same conditions (i.e. the same power of the source and the same spectrometer parameters). These spectra are compared with a reference fibre mirror. The reference fibre mirror is a commercial component that was devised to back-reflect 100% of the light coming from the source. An evanescent wave sensor provides back reflection of a portion of the source light, since part of it is scattered in the surrounding environment (i.e. the sample). A trade-off occurred between the length of the sensor and the back-reflected signal: the short sensors exhibited low sensitivity, whereas the long sensors did not provide enough back-scattered signal to be probed. An experimental optimization of different sensors lengths showed that the 2 cm long embedded sensors could not detect water diffusion, as their sensitive parts were not long enough, and the embedded sensors longer than 10 cm did not provide a useful back-scattered signal, as the light was scattered. The embedded sensors, with lengths of between 6 to 10 cm, were able to yield a back-reflected signal close to that of the reference mirror, while exhibiting sensitivity to water diffusion. Therefore, the standard length for the subsequent water diffusion experiments was set to 8 cm.

Moreover, a recurring problem was the breakage of the embedded optical fibres during or shortly after epoxy curing, due to the stress induced at the air-resin-optical fibre interface. This issue represents a serious drawback to the deployment of OFSs in harsh environments, or in any applications where sensors must be sturdy and long-lasting. OFSs working in transmission have two terminations, and this makes the concern even more relevant, because of the double probability of breakage. The sensors presented in this work limit the likelihood of breakage since they behave like single termination probes, and an effective strategy was thus implemented to further enhance their long-term mechanical reliability. The problem was here solved by protecting the insertion of the fibre with a 40 mm long thermally-shrinking protection sleeve.

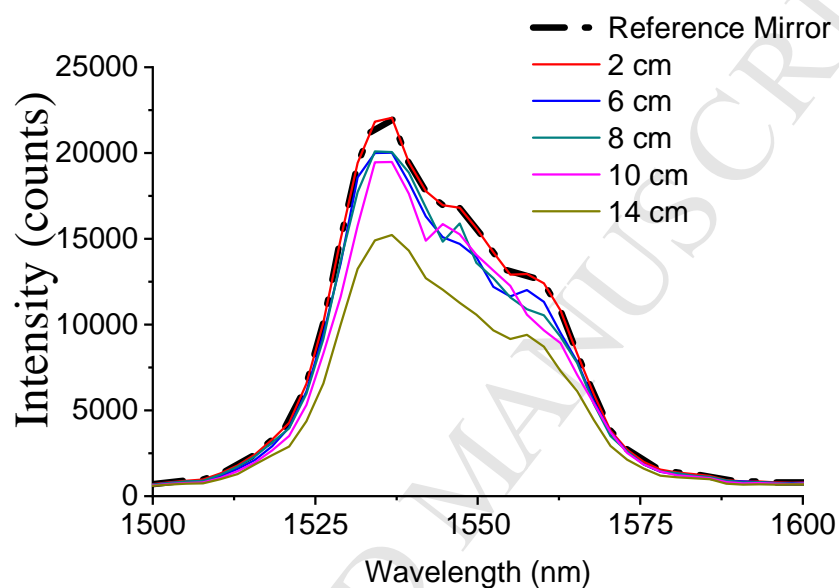

Figure 5. Experimental optimization of the length of the optical fibre sensors obtained from a comparison of the back-reflected spectrum with that of a reference fibre mirror.

### 3.3 Characterization of the embedded sensors

Figure 6 A) shows the cross-section of an OFS embedded in an epoxy matrix. The image highlights good adhesion between the optical fibre and the resin, without any unbound sections. Figure 6 B) shows the Cu-OFS embedded in the epoxy resin. The adhesion at the epoxy interface is good and the Cu coating is continuous and has adhered well to the silica fibre sensor.

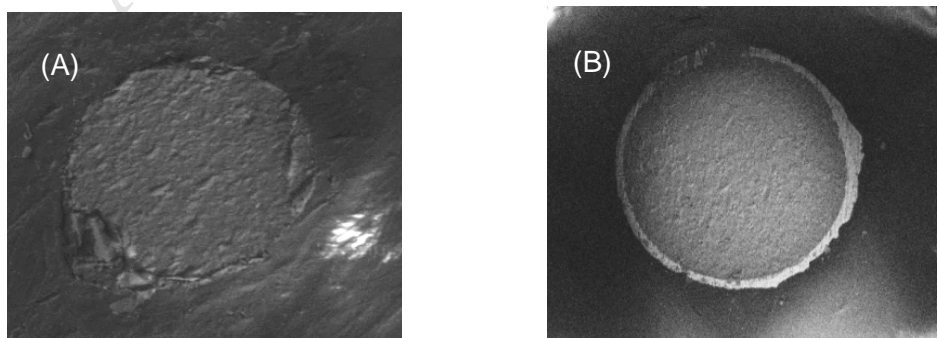

Figure 6. SEM micrographs of the cross section of (A) an OFS and (B) a Cu-OFS embedded in the epoxy resin.

Epoxy specimens with an embedded OFS and a Cu-OFS were immersed into sea water at 80 °C for up to 144 h. The reflected signal from the sensors was recorded every 5 minutes. Figure 7 A) depicts the reflected signal from an OFS in the near-infrared spectrum (1500-1600 nm), recorded at different exposure times. A remarkable signal drop occurred at 48 h, and this drop was in agreement with the diffusion length of water calculated from the  $D$  coefficient and the distance of the sensor from the surface. On the other hand, the dummy sensor did not exhibit any changes in the measurement uncertainty (Figure 7 B). This confirmed that the information from OFSs could be ascribed to the diffusion of sea water rather than to spurious effects, such as thermal expansion. The signal from the Ag-OFS decreased from the initial value of  $\sim 16 \cdot 10^3$  counts and flattened to  $4 \cdot 10^3$  counts, correspondent to an homogeneous decrement of  $\sim 75\%$  in 144 h in the 1500-1600 range.

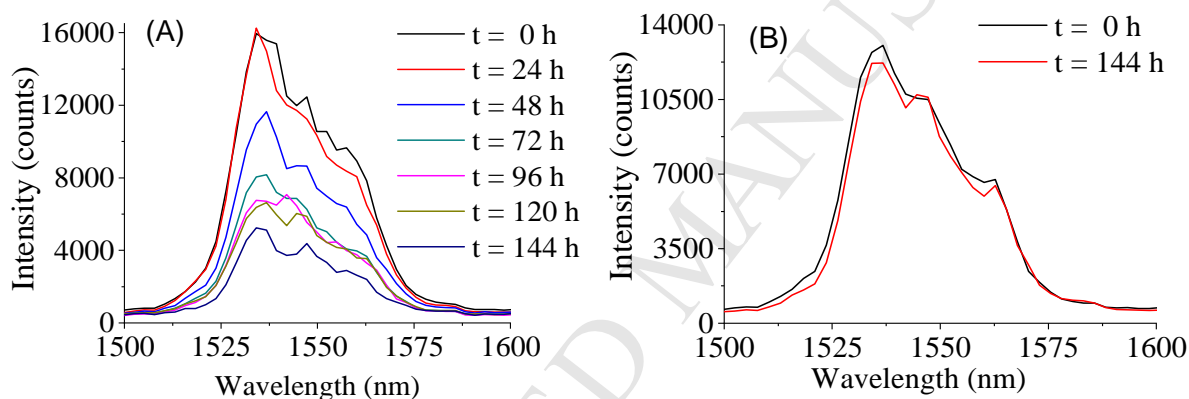

Figure 7. A) Reflected spectra of an OFS embedded in the epoxy exposed to simulated sea water at 80°C. Spectra were collected every 5 min, but only the relevant curves are reported here. B) Reflected spectra of a Cu-OFS embedded in the epoxy exposed to simulated sea water at 80°C.

In order to check the reversibility of the sensing system, after exposure to sea water, the specimens were dried at 80 °C for 2 weeks. As shown in Figure 8, the response of the embedded OFS is completely reversible: when the water is not present in the epoxy resin surrounding the sensitive region of the OFS, the signal intensity is comparable with that measured before the ageing test.

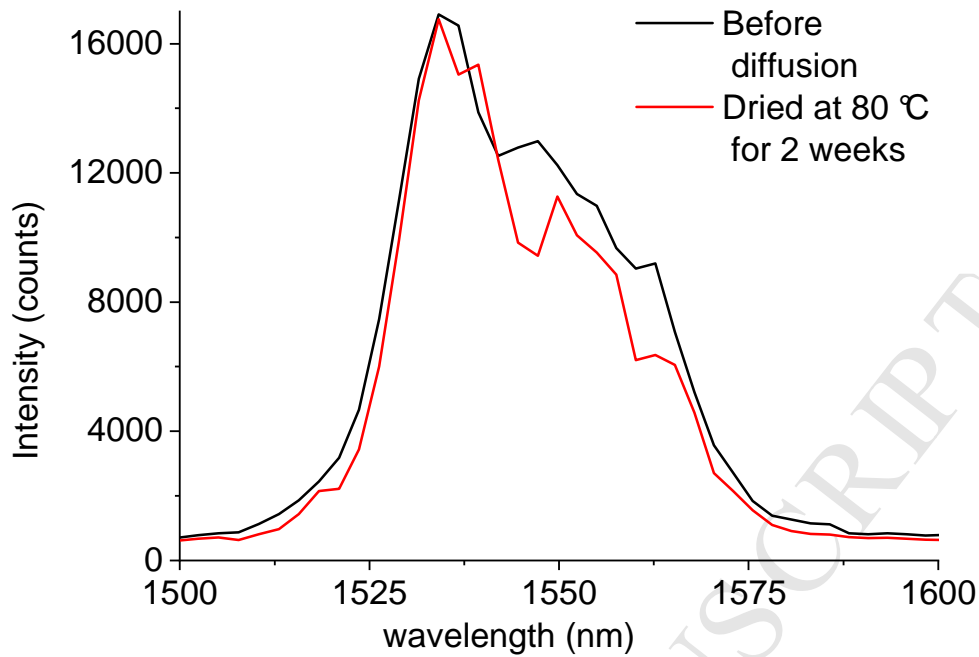

Figure 8. Reflected spectrum before water diffusion (black) and after the water-diffused sample was dried at 80°C for two weeks (red).

In order to detect the diffusion through the thickness of the epoxy matrix, a number of samples with sensors embedded at different depths were subjected to accelerated water diffusion experiments. The samples were subjected to long-term exposure (up to 4 days) to sea water at 80°C, with the signals from the optical fibre sensors continuously recorded. An example of a recording outcome is reported in Figure 9, where the signal from a sensor embedded at 2.6 mm from the surface is shown. A sharp decrease occurs after ~49h, when sea water reaches the epoxy matrix in contact with the sensor. With this time information it is possible to evaluate the water diffusion depth, assuming that the process follows the Fick's law (eq. 2):

$$d = 2 \sqrt{\int_0^t D(\tau) d\tau} \quad (2)$$

where:  $d$  is the distance of the water diffusion, " $t$ " the time corresponding to the signal drop and " $D$ " is the diffusion constant ( $8.8 \times 10^{-12} \text{ m}^2/\text{s}$ ).

The samples were later cross-sectionally cut a number of times and inspected with a calibrated microscope to measure the average depth of each sensor (one must take into account that during the embedding process the fibres may not be perfectly parallel to the sample's surface and the depth of each fibre may vary along the sample). In all samples the measured position resulted to be consistent with the diffusion depth expected from a Fickian process.

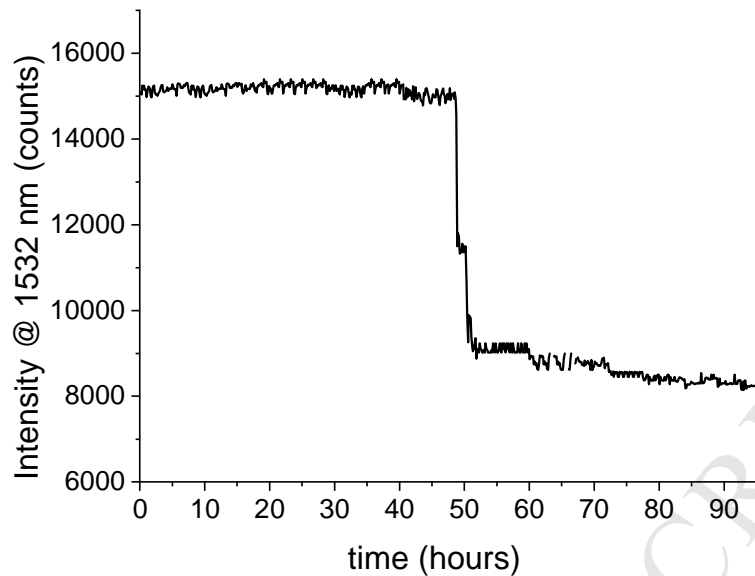

Figure 9. Example of signal recorded from a sensor embedded into an epoxy sample at depth 2.6 mm. The signal drop occurs after a 49 hours exposure of the sample to salty water diffusion (accelerated test at 80 °C). The diffusion length expected from eq. 2 is 2.5 mm.

As an example, the results of a sample containing 8 sensors at depths ranging from 0.8 to 2.3 mm are summarized in table 3. This table compares the diffusion length estimated with Fick's law (eq. 2) with the actual depth of the sensor that has detected the diffusion. Since the uncertainty on  $d$  is about  $\pm 0.2$  mm (stemming from the measure with the optical microscope), a reasonably good agreement emerges between the columns, which demonstrates that the optical fibre sensors are capable of detecting the diffusion of water through the polymer with good temporal confidence. The overall monitoring process still requires improvements (reproducibility of the fabrication process of the sensors and positioning of the sensors into the sample). However, it demonstrates to be an effective diagnostic tool for pre-emptive maintenance and the results are expected to be easily extended to glass fibre reinforced polymers (GFRPs), paving the way towards the development of "sensitive" GFRP artefacts for harsh environments (oil&gas, aerospace, energy).

Table 3. Calculated and measured diffusion heights

Sensor n°	Sensor distance from the epoxy surface	
	Calculated from Fick's law (mm) $D= 8.8 \times 10^{-12} \text{ m}^2/\text{s}$	Experimentally measured (mm)
1	0.8	$0.5 \pm 0.2$
2	0.9	$0.9 \pm 0.1$
3	0.9	$0.8 \pm 0.2$
4	1.1	$1.4 \pm 0.1$

<b>5</b>	1.1	1.0±0.2
<b>6</b>	1.2	1.2±0.1
<b>7</b>	1.7	1.5±0.1
<b>8</b>	2.3	2.2±0.1

## CONCLUSIONS

Novel, single-ended optical fibre sensors for the detection of water diffusion were fabricated, embedded and tested in an epoxy resin for glass fibre reinforced polymers. An effective process was developed to fabricate the sensors by etching the cladding of the optical fibres and creating a reflective termination with the Tollen's reagent. A procedure to produce the epoxy samples and to embed the optical fibre sensors was developed and experimentally optimized through physical and optical measurements. A setup for continuous monitoring of the sensors was designed, with off-the-shelf telecommunication components, to remotely track up to 16 sensors. Accelerated diffusion tests were performed in simulated sea water at 80°C for up to ~150h. These experiments showed that it was possible to detect water diffusion by observing drops of spectral reflection from the sensors. The water diffusion process, as well as the response from the optical fibre sensors, were found to be reversible. By embedding optical fibre sensors at different depths, it was possible to assess the diffusion through the thickness of the epoxy samples.

Overall, this work yields preliminary experimental proof of the feasibility of fibre reinforced polymers equipped with sensors, that could be used in harsh environments (such as in pipes exposed to sea water diffusion), whose structural integrity could be remotely monitored with a simple, electric-free system, and any possible failures could be detected at early stages.

## Acknowledgements

The research leading to these results has received funding from the European Union's Horizon 2020 research and innovation programme under the Marie Skłodowska-Curie grant agreement No. 642557.

## REFERENCES

- [1] M. Roseman, R. Martin, G. Morgan, 10 – Composites in offshore oil and gas applications, in: *Mar. Appl. Adv. Fibre-Reinforced Compos.*, 2016: pp. 233–257. doi:10.1016/B978-1-78242-250-1.00010-7.
- [2] R. Rafiee, On the mechanical performance of glass-fibre-reinforced thermosetting-resin pipes: A review, *Compos. Struct.* 143 (2016) 151–164. doi:10.1016/J.COMPSTRUCT.2016.02.037.
- [3] V.A. Guzman, P. Brøndsted, Effects of moisture on glass fiber-reinforced polymer composites, *J. Compos. Mater.* 49 (2015) 911–920. doi:10.1177/0021998314527330.
- [4] A.V. Oskouei, M. Bazli, H. Ashrafi, M. Imani, Flexural and web crippling properties of GFRP pultruded profiles subjected to wetting and drying cycles in different sea water conditions, *Polym.*

- Test. (2018). doi:10.1016/J.POLYMERTESTING.2018.05.038.
- [5] AD5933 Datasheet and Product Info | Analog Devices, (n.d.). <http://www.analog.com/en/products/rf-microwave/direct-digital-synthesis/ad5933.html> (accessed August 29, 2017).
- [6] S.A. Grammatikos, R.J. Ball, M. Evernden, R.G. Jones, Impedance spectroscopy as a tool for moisture uptake monitoring in construction composites during service, *Compos. Part A Appl. Sci. Manuf.* 105 (2018) 108–117. doi:10.1016/J.COMPOSITESA.2017.11.006.
- [7] S. Giannis, Element Materials Technology Hitchin Ltd (UK), Private communication, (2015).
- [8] D.C. Lee, J.J. Lee, S.J. Yun, The mechanical characteristics of smart composite structures with embedded optical fiber sensors, *Compos. Struct.* 32 (1995) 39–50. doi:10.1016/0263-8223(95)00038-0.
- [9] T.J. Young, M.J. Lodeiro, M.R.L. Gower, M.B. Sassi, Systematic approach for the calibration of humidity sensitive polyimide recoated fibre Bragg gratings for measuring humidity and temperature and their application for measuring moisture absorption in polymers, *Meas. Sci. Technol.* 24 (2013) 085101. doi:10.1088/0957-0233/24/8/085101.
- [10] M. Olivero, G. Perrone, A. Vallan, D. Tosi, Comparative Study of Fiber Bragg Gratings and Fiber Polarimetric Sensors for Structural Health Monitoring of Carbon Composites, *Adv. Opt. Technol.* 2014 (2014) 1–8. doi:10.1155/2014/804905.
- [11] K. Peters, Polymer optical fiber sensors—a review, *Smart Mater. Struct.* 20 (2011) 013002. doi:10.1088/0964-1726/20/1/013002.
- [12] side-polished-fibers, (n.d.). <http://www.phoenixphotonics.com/website/technology/side-polished-fibers.html> (accessed October 4, 2017).
- [13] L. Wang, A. Tomlin, S.D. Pandita, B.D. Gupta, S.A. Malik, M. Hudson, P.T. Curtis, G.F. Fernando, In-situ monitoring of cross-linking reactions using E-glass fibres and evanescent wave spectroscopy, *Sensors Actuators B Chem.* 236 (2016) 358–366. doi:10.1016/J.SNB.2016.05.126.
- [14] S.M. Milsom B. , Olivero M. , Milanese D, Roseman M. , Giannis S., Martin R. , Terenzi A., Ferraris M., Development and integration of innovative glass fibre sensors into advanced composites for applications in hostile environments, in: *Eur. Conf. Compos. Mater., Selville (Spain), 2014.*
- [15] ASTM D1141 - 98(2013) Standard Practice for the Preparation of Substitute Ocean Water, (n.d.). <http://www.astm.org/Standards/D1141.htm> (accessed September 10, 2014).
- [16] B. Milsom, M. Olivero, D. Milanese, S. Giannis, R.H. Martin, A. Terenzi, J. Kenny, M. Ferraris, G. Perrone, M. Salvo, Glass optical fibre sensors for detection of through thickness moisture diffusion in glass reinforced composites under hostile environments, *Adv. Appl. Ceram.* 114 (2015) S76–S83. doi:10.1179/1743676115Y.0000000034.
- [17] M. Montazer, F. Alimohammadi, A. Shamei, M.K. Rahimi, In situ synthesis of nano silver on cotton using Tollens reagent, *Carbohydr. Polym.* 87 (2011) 1706–1712. doi:10.1016/j.carbpol.2011.09.079.
- [18] P. Dhara, V.K. Singh, M. Olivero, G. Perrone, Reflectance-based low-cost disposable optical fiber surface plasmon resonance probe with enhanced biochemical sensitivity, *Opt. Eng.* 55 (2016) 046114.



doi:10.1117/1.OE.55.4.046114.

- [19] NoFAST-SC-APC Connector, 2009.
- [20] Lynx CustomFit Splice-On SC Connector datasheet, 2010.
- [21] Avantes Spectrometers, (n.d.). <https://www.avantes.com/> (accessed July 20, 2010).
- [22] M.H.G. Wichmann, L.O. Meyer, K. Schulte, SCIENCE AND Load and health monitoring in glass fibre reinforced composites with an electrically conductive nanocomposite epoxy matrix, 68 (2008) 1886–1894. doi:10.1016/j.compscitech.2008.01.001.
- [23] G. Lachenal, A. Pierre, N. Poisson, FT-NIR spectroscopy: Trends and application to the kinetic study of epoxy/triamine system (Comparison with DSC and SEC results), Micron. 27 (1996) 329–334. doi:10.1016/S0968-4328(96)00022-4.
- [24] A. Rigail-Cedeño, C.S.P. Sung, Fluorescence and IR characterization of epoxy cured with aliphatic amines, Polymer (Guildf). 46 (2005) 9378–9384. doi:10.1016/j.polymer.2005.04.063.
- [25] N. Poisson, G. Lachenal, H. Sautereau, Near-and mid-infrared spectroscopy studies of an epoxy reactive system, Vib. Spectrosc. 12 (1996) 237–247.
- [26] J.M.M. S.A. Grammatikos, B. Zafari, M.C. Evernden, J.T. Mottram, Moisture uptake characteristics of a pultruded fibre reinforced polymer flat sheet subjected to hot/wet aging, Polym. Degrad. Stab. 121 (2015) 407–419. doi:10.1016/J.POLYMDEGRADSTAB.2015.10.001.

**Highlights**

- Epoxy matrix for glass fibre reinforced polymers
- Low cost optical fibre sensors for the early detection of water diffusion
- Accelerated diffusion tests
- water diffusion resulted in a remarkable change of the reflected signal from the sensors