

Proc. Eurosensors XXV, September 4-7, 2011, Athens, Greece

Response dynamics of metal oxide gas sensors working with temperature profile protocols

A. Ponzoni^a (a*), A. Depari^b, E. Comini^{a,c}, G. Faglia^{a,c}, A. Flammini^b, G. Sberveglieri^{a,c}

^aCNR-IDASC, Unit of Brescia SENSOR, Via Valotti 9, 25133 Brescia, Italy

^bDepartment of Electronics for Information Engineering, University of Brescia, Via Branze 38, 25123 Brescia, Italy

^cDepartment of Chemistry and Physics, University of Brescia, Via Valotti 9, 25133 Brescia, Italy

Abstract

In this work we present the analysis of gas sensors working in modulated temperature mode with temperature varying according to exponential law. We integrate conductometric gas sensor based on semiconducting metal oxide layers and an ad-hoc developed electronics to present a sensing system based on a single sensor featuring a degree of selectivity arising from the exploitation of response dynamics features. In particular, a set of parameters is used to summarize the deviation of the response shape from the single exponential law.

© 2011 Published by Elsevier Ltd. Open access under [CC BY-NC-ND license](https://creativecommons.org/licenses/by-nc-nd/4.0/).

Keywords: semiconductor gas sensors; temperature modulation; dynamic response; tungsten oxide, wide-range conductances

1. Introduction

Measurements protocols using temperature profiles [1] are attractive because of the large amount of information (features) they allow to extract, compared with isothermal protocols. From a chemical-physical point of view, a larger information arises because of the different thermodynamic conditions explored in temperature cycles. At the same time, the full exploitation of these protocols requires the use of control electronics featuring the capability to work with a fast clock and read the sensor conductance through the wide range that would be spanned during temperature cycles. Despite commercial solutions exist, their high cost makes the sensing system (sensor and control/readout electronics) quite expensive,

* Corresponding author. Tel.: +39-030-3715707; fax: +39-030-2091271.

E-mail address: andrea.ponzoni@ing.unibs.it.

in contrast with the philosophy underlying sensor development. To this aim, the authors developed a cheap readout electronics suitable to perform fast measurements (10 ms) over a wide range of values (10 pS - 100 μS), [2]. In a previous work, we used a first prototype of the system to control an array of four metal oxide (MOX) based chemiresistors to measure their static response and exploit the selectivity of the array to discriminate key-aromas developed during bread baking [3]. The electronic system has been further developed to control the sensor temperature in order to develop an autonomous device (sensor and electronics) fulfilling the requirements of reduced cost, fast readings, wide range of measurable conductance. In this work, we use this system to analyze the dynamic response of a WO₃-based gas sensor exposed to different concentrations of ethanol and methane in different humidity conditions. The use of temperature protocols allows obtaining different features summarizing the static and dynamic response of the device to the different test-atmospheres.

2. Experimental

An ad-hoc electronic circuit has been designed for the complete and flexible management of resistive chemical sensors, such as metal oxide devices. Fig. 1 (a) shows the front-end used for the estimation of the sensor parameters; in particular the system is capable to estimate the sensor conductance G_S as well as a parasitic capacitance C_S , modeled in parallel with G_S . It is based on a conductance-to-time conversion (CTC) scheme, which allows a wide range of conductances to be estimated without using scale factors. To obtain a short measuring time (10 ms), an interpolation method, by means of the least means square algorithm, is used whenever the CTC approach requires a longer time to be accomplished [2].

Fig.1 (b) shows the block scheme of the complete system, detailing the stage devoted to the thermal management of the sensor [4]. The sensor heater is driven by a user-programmable voltage V_{tot} , furnished by means of a digital to analog (D/A) converter followed by a current boost. The current I_h flowing through the sensor heater is estimated by means of the voltage drop V_{sh} on the shunt resistor R_{sh} , and then acquired by means of an analog to digital (A/D) converter. Thus, the actual heater voltage V_h can be easily computed and, together with the estimated value of I_h , allows both the heater resistance R_H and the heater power P_H to be reckoned. Every measuring cycle (10 ms), a new value of V_{tot} can be provided and a new estimation of the heater parameters is carried out, in a synchronous way with G_S and C_S estimations. Thus, it is possible to apply various thermal profiles and to finely track both the sensor and the heater behavior.

Finally, collected data are sent every cycle via a serial link to a PC, where a human interface application in LabVIEW environment allows the user to set the measurement parameters, to create the desire thermal profile and to save the sensor data for off-line analysis.

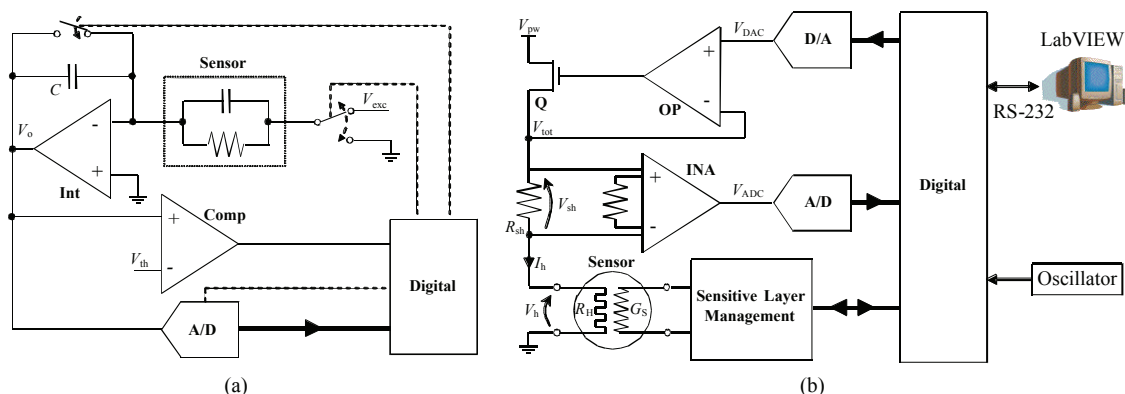

Fig. 1: (a) scheme of the sensor interface; (b) scheme of the complete system, with a detail of the sensor heater management stage.

The WO_3 layer used as sensing element has been prepared over a 2 mm x 2mm x 0.25 mm alumina substrate by a modified thermal evaporation method detailed in [5]. Interdigitated electrical contacts spaced by 200 μm were deposited by Sputtering DC over the oxide layer. The device was provided by a Pt meander (deposited by Sputtering DC) acting both as heating element and temperature probe on the substrate back side.

Measurements were carried out by flow through method working with a constant flow of 300 sccm in a thermostatic sealed chamber at room pressure under controlled humidity conditions (RH=0-50% @ 20°C). Controlled gas mixtures were obtained by using mass flow controllers mixing flows from certified bottles.

3. Results and Discussion

The response dynamics of the WO_3 sensor working in temperature-modulated mode during the exposure to different atmospheres are compared in Fig. 2 (a).

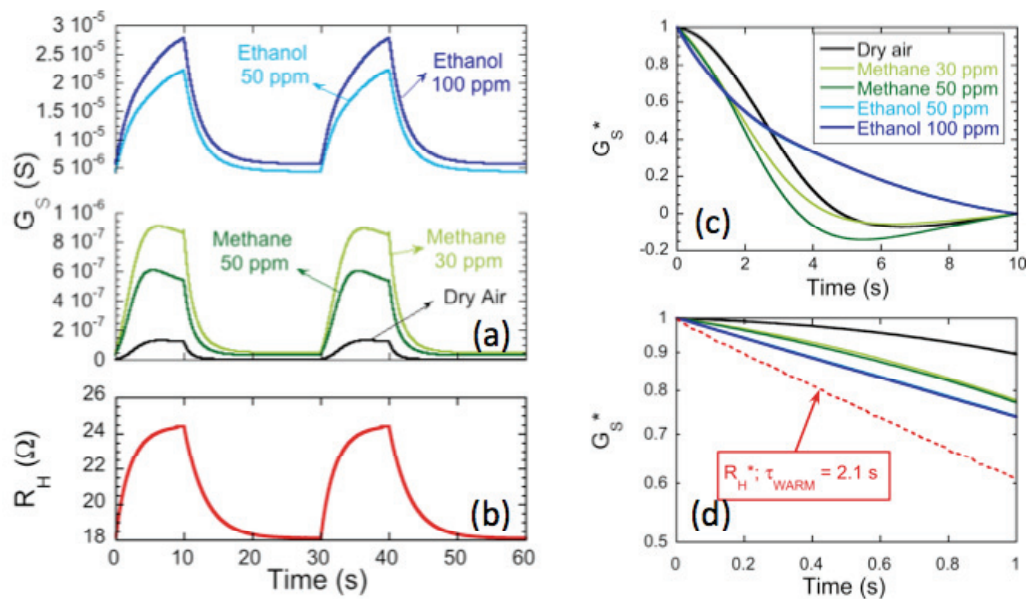

Fig. 2: (a) conductance dynamics of the sensing layer (G_s) exposed to different gases and concentrations in a dry air background; (b) time dependence of the heating element resistance (R_H); (c) sensing element conductance normalized according to Eq. (1), G_s^* extrapolated from the (first) heating cycle of (a); (d) zoom over the initial stage of the (c)-plot, showing the time constant of the initial stage of G_s .

The observed dynamics arise both from a direct conductance modulation induced by the temperature profile of the device as well as from the temperature-dependent interactions occurring among the semiconducting WO_3 layer and the gaseous environment. In particular, the adopted temperature-protocol consists of a voltage square-wave applied to the heating element. This induces a sequence of exponential rise and decay of the device temperature in the range from 200 to 400 °C. The device temperature is tracked by measuring the heating element resistance (R_H , Fig. 2(b)), whose value is proportional to its temperature. The time dependence of the temperature has been found to behave according to a single exponential (time-constant) law, so that, in a vertical log scale (Fig. 2 (d)), the normalized heater

resistance R_H^* calculated according to Eq. (1), is linear:

$$R_H = R_{H,f} - (R_{H,f} - R_{H,0})e^{-t/\tau}; \quad R_H^*(t) = \frac{R_{H,f} - R_H(t)}{R_{H,f} - R_{H,0}} = e^{-t/\tau} \quad (1)$$

where 0 and f subscripts stand for initial and final respectively.

Independently of the surrounding atmosphere, time constants of 2.1 s and 2.9 s have been extrapolated for the heating and cooling cycles respectively,

The shape of the sensing layer conductance G_S rise and fall during the heating and cooling cycles is analyzed through a normalized conductance, G_S^* , calculated according to Eq. (1). G_S^* allows to analyze the response dynamics according to their deviation from the single exponential law. According to Fig. 2 (c), deviations are observed for all the tested gases and concentrations, but ethanol, with G_S^* reaching its minimum before the end of the heating (cooling) cycle. Ethanol, differently, induces a peculiar response shape quite close to the basic model depicted in Eq (1) for most of the cycle.

The shape of G_S^* can be summarized through a set of parameters such as: the time constant that can be extrapolated from the initial stage of heating/cooling cycles (τ_0), the time and value of the G_S^* minimum (t_{\min} and $G_{S,\min}^*$). In the case of ethanol, t_{\min} coincides with the end of the cycle and $G_{S,\min}^*$ is null (according to the definition provided by Eq (1)).

The approach provides a set of parameters featuring a marked analyte dependence (and a weak concentration dependence) that can be coupled with typical response amplitude parameters (e.g. ΔG_S), which exhibit enhanced concentration dependence, but a reduced analyte dependence. For example, during the sensor exposure to the air background, τ_0 extrapolated during the warming cycle ranges from 20 to 25 s, depending on relative humidity (0-50%), while, in presence of ethanol, the same parameter ranges between 5 and 15 s (whichever the RH value, 0-50%), providing a useful parameter to separate ethanol from the humidity background.

Acknowledgements

The research leading to these results has received funding from the QUT Queensland Government Smart Futures Fund-National and International Research Alliances Program 2008-09 (NIRAP) “Solar powered nano-sensors for data acquisition and surveying in remote areas” and the European Community’s 7th Framework Programme, under the grant agreement n° 247768, and from the Russian Federation Government, under the State Contract 02.527.11.0008, within the collaborative Europe-Russia S3 project.

References

- [1] Lee AP, Reed BJ. Temperature modulation in semiconductor gas sensing. *Sens. Actuators B-Chem* 1999; **60**: 35 – 42.
- [2] Depari A, Flammini A, Marioli D, Sisinni E, Comini E, Ponzoni A. A10 ms-read out interface for the characterization of high value wide-range experimental resistive sensors. *Sens. Actuators B-Chem* 2010; **146**: 495 – 501.
- [3] Ponzoni A, Depari A, Falasconi M, Comini E, Flammini A, Marioli D, Taroni A, Sberveglieri G. Bread baking aromas detection by low-cost electronic nose. *Sens. Actuators B-Chem* 2008; **130**: 100 – 104.
- [4] Depari A, Flammini A, Marioli D, Sisinni E, Comini E, Ponzoni A. An Electronic System for the Thermal Management of MOX Sensors. *Proc. of SAS* 2011; 292-297.
- [5] Ponzoni A, Comini E, Ferroni M, Sberveglieri G. Nanostructured WO_3 deposited by modified thermal evaporation for gas-sensing applications. *Thin Solid Films* 2005; **490**: 81 – 85.