

Proc. Eurosensors XXV, September 4-7, 2011, Athens, Greece

Active rectifier circuits with sequential charging of storage capacitors (SCSC) for energy harvesting in autonomous sensors

D. Alghisi, M. Ferrari*, V. Ferrari

Department of Information Engineering, University of Brescia, Via Branze 38 – 25123, Brescia, Italy

Abstract

In this paper, different configurations of self-powered active rectifier circuits for energy harvesting in autonomous sensors are proposed. The circuits perform the conversion of the AC voltage provided by the mechano-electrical energy converter, and store the energy into multiple capacitors. The proposed Sequential Charging of Storage Capacitors (SCSC) technique has been developed to improve the energy extracted from converters with non-deterministic output voltage over a limited duration. Experimental results show that SCSC active rectifier circuits allow an increase of up to 147% of the stored energy versus passive rectifiers at same mechanical input.

© 2011 Published by Elsevier Ltd. Open access under [CC BY-NC-ND license](#).

Keywords: energy harvesting; active rectifier circuit; magneto-dynamic energy converter.

1. Introduction

Typically an energy harvesting system consists of a device that converts the energy available in the environment in which it operates into electricity. Considering the technological advances in the development of low-power electronic devices, it is possible to use that energy to power an autonomous sensorized system. Generally converters cannot directly supply an electronic device, because the characteristics of the energy sources from the environment are not deterministic, and furthermore the physical principle of energy conversion could deliver an AC voltage, instead of the required DC one. So it is necessary to connect the converter to a system that

* Corresponding author. Tel.: +39-030-3715899; fax: +39-030-380014.
E-mail address: marco.ferrari@ing.unibs.it.

is able to store and deliver the energy at a useful DC voltage level in order to power a sensorized electronic system for enough time. In this work a power management system that stores the electrical energy delivered by a magneto-dynamic converter in capacitors using active rectifier circuits following an innovative concept is presented.

2. Rectifier circuits

To perform the conversion of an AC voltage into a DC voltage, passive circuits can be used, typically consisting of combinations of diodes and storage capacitors [1-4]. A limitation of passive rectifier circuits lies in the voltage drop across the diodes, which determines a reduction for both voltage and energy levels reached into storage capacitors [5]. Possibilities to overcome these limitations are to replace diodes with MOSFET transistors driven by comparators as voltage-controlled switches [6, 7], or to use a switching capacitor network able to charge the storage capacitors in parallel and then switching them in series to power the load [8].

In the present work, traditional configurations of passive rectifier circuits have been redesigned, using MOSFET transistors instead of diodes, and including an innovative switching capacitor network which sequences the charging of storage capacitors, called Sequential Charging of Storage Capacitors (SCSC). Half-wave, full-wave and voltage doubler active rectifier circuits, with and without SCSC, are proposed.

For example, the full-wave active rectifier circuit is shown in Fig. 1. U_1 and U_2 are nanopower push-pull output comparators, Q_1 and Q_2 are P-channel and N-channel Power MOSFET respectively, with r_{DSon} in the order of hundreds of milliohms for $|v_{GS}| > 2.5$ V, C_1 and C_2 are electrolytic capacitors with capacitance values in the order of millifarads. To power the active components used in the rectifier circuits proposed, a dual voltage multiplier circuit based on Schottky diodes has been integrated in each configuration. The voltage multiplier uses the input voltage v_t to charge capacitors of few microfarads in order to promptly provide a DC supply voltage adequate to power the active rectifier circuit.

Unfortunately, when the voltages on storage capacitors are larger than the input voltage, no charge is collected on capacitors. To overcome that limitation, the innovative concept of the SCSC network has been included in the rectifier circuits. For example, the voltage doubler active rectifier circuit with SCSC is shown in Fig. 2. The high-speed CMOS decade counter U_5 enables the Single-Pole Double-Throw (SPDT) analog switch SW_1 that connects the first storage capacitor to the active rectifier circuit. When the voltage on the capacitor which is charging reaches the adjustable threshold voltage V_{ref} set by the low-power and low-dropout voltage reference U_4 , the counter is incremented in order to disconnect the first capacitor and let the next capacitor charge through the rectifier circuit. This process is repeated until the input voltage v_t is no

longer able to charge storage capacitors up to voltage V_{ref} . The capacitors that are not being charged through the rectifier circuit are accessible through the other pole of their own SPDT, and connected by Schottky diodes to an high-efficiency charge-pump DC-DC converter in order to provide a regulated 3 V DC supply voltage. Adjusting the threshold voltage V_{ref} as a function of the maximum input voltage amplitude, it is possible to maximize the effectiveness of the rectifier circuit. Similar architectures have been designed in order to implement half-wave and full-wave active rectifier circuits with SCSC.

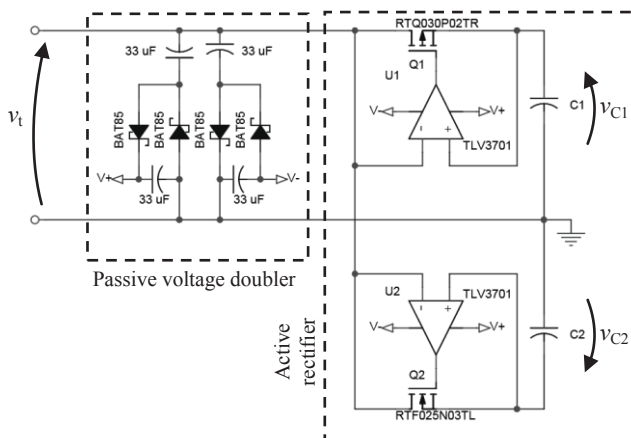

Fig. 1: Full-wave active rectifier circuit proposed.

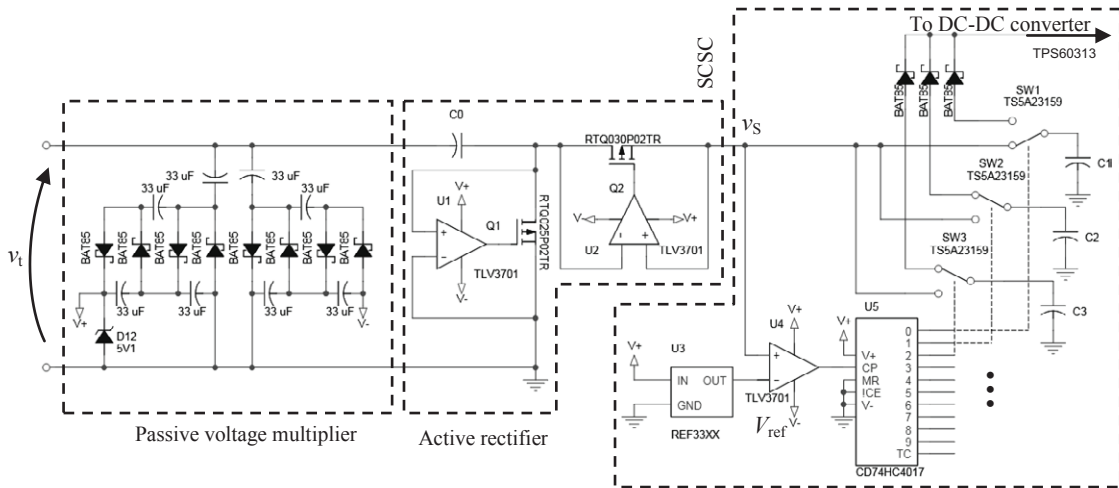

Fig. 2: Active voltage doubler rectifier circuit with sequential charging of storage capacitors (SCSC) proposed.

3. Experimental results

A commercial magneto-dynamic energy converter is used to characterize the proposed active rectifier circuits. The converter, shown in Fig. 3, is a macroscopic portable low-cost mechanical system that converts the force imposed by a human hand in a rotational movement of a group of permanent magnets coupled with an electrical coil. The converter can be modeled electrically as a voltage generator with a series resistor R_S and inductor L_S whose typical values are $R_S = 18.8 \Omega$ and $L_S = 4.7 \text{ mH}$. Fig. 3a shows the typical open circuit AC voltages v_t provided by the converter. Typical values of the voltage v_t are between 3.5 V to 7 V for an applied force between 10 N to 40 N. Fig. 3b shows the output frequency f_t that for the same applied forces reaches a maximum value from 150 Hz and 400 Hz. The converter is able to provide a maximum short-circuit current less than 220 mA, and the duration of the generated voltage is in the order of few seconds, depending on the applied force. In Fig. 4 typical measured voltages across the storage capacitors and power supply voltages of the active full-wave rectifier circuit are shown. In Fig. 5 the sequential charge of the storage capacitors for the active voltage doubler rectifier with SCSC is shown. A comparison between junction-diode and Schottky-diode passive rectifier circuits, and the proposed active rectifier circuits was performed varying the applied force on

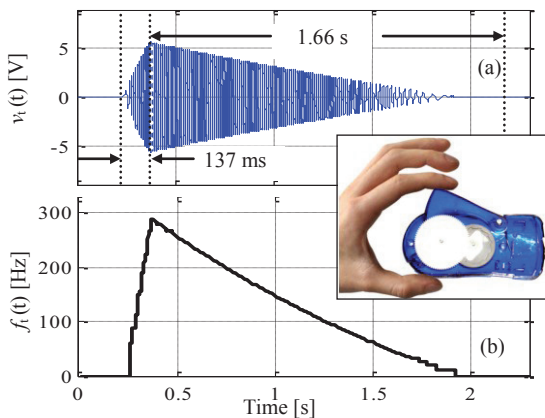

Fig. 3: Measured open-circuit output voltage v_t (a), and measured output frequency f_t (b) provided by the converter with an applied force of 19.6 N.

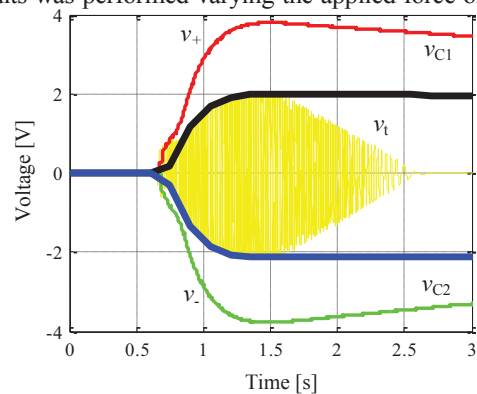

Fig. 4: Measured output voltage v_t of the converter, voltages v_{C1} , v_{C2} on storage capacitors ($C_1 = C_2 = 4.4 \text{ mF}$), and supply voltages v_+ and v_- for the full-wave active rectifier circuit shown in Fig. 1.

the energy converter, the capacitance of storage capacitors from 0.47 mF to 18.8 mF, and the threshold voltage of the switching network from 1.2 V to 2.5 V. As shown in Fig. 6, the proposed active rectifier circuits generally allow to store up to 147% more energy than the corresponding passive circuits. The typical current supply for the active devices present in active rectifier circuits with SCSC is between 7 μ A and 12 μ A, and a voltage level higher than 2 V. With an applied force of about 29.5 N, the voltage doubler active rectifier circuit with SCSC is able to store 27.5 mJ of energy in six 2.2 mF capacitors, with $V_{ref} = 2.05$ V. The storage capacitors were connected to a DC-DC converter and the energy was used to power a custom contactless temperature sensor module that visualizes the readings on a LCD display for about 17 s.

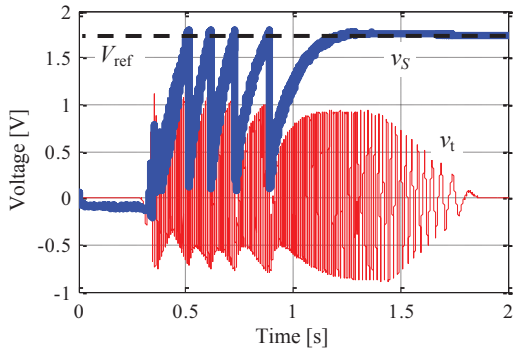

Fig. 5: Measured output voltage v_t of the converter, and voltages v_s on storage capacitors ($C = 2.2$ mF, $V_{ref} = 1.8$ V) for the active voltage doubler rectifier circuit with sequential charging of storage capacitors (SCSC) shown in Fig. 2.

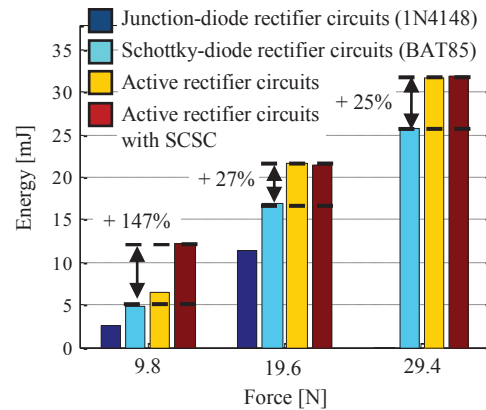

Fig. 6: Comparison between different configurations of rectifier circuits proposed for different applied forces.

4. Conclusions

A power management system that stores the electrical energy delivered by a magneto-dynamic energy converter into storage capacitors was presented. Innovative active self-powered rectifier circuits, also provided with the SCSC network, were designed, realized and characterized. The experimental results show that active rectifier circuits with SCSC are able to store up to 147% more energy in the storage capacitors compared to passive rectifier circuits.

References

- [1] Yuantai, Hu, Ting, Hu e Qing, Jiang. Coupled analysis for the harvesting structure and the modulating circuit in a piezoelectric bimorph energy harvester. *Acta Mechanica Solida Sinica*. 2007, Vol. 20 (4), p. 296-308.
- [2] Lesieutre, G.A., Ottman, G.K. e Hofmann, H.F. Damping as a result of piezoelectric energy harvesting. *Journal of Sound and Vibration*. 2004, Vol. 269 (3-5), p. 991-1001.
- [3] Qui, Jinhao, et al. Comparison between four piezoelectric energy harvesting circuits. *Frontiers of Mechanical Engineering in China*. 2009, Vol. 4 (2), p. 153-159.
- [4] Ferrari, M., et al. Investigation on Electrical Output Combination Options in a Piezoelectric Multifrequency Converter Array for Energy Harvesting in Autonomous Sensors. The First International Conference on Sensor Device Technologies and Applications, SENSORDEVICES 2010, Venice/Mestre (Italy), July 18-25, 2010, p. 258-263.
- [5] M.T. Zhang. Electrical, thermal, and EMI designs of high-density, low-profile power supplies. Ph. D. Dissertation, Virginia Polytechnic Institute and State University, 1997.
- [6] T.T. Le, H. Jifeng, A. von Jouanne, K. Mayaram, T.S. Fiez. Piezoelectric Micro-Power Generation Interface Circuits. *IEEE Journal of Solid State Circuits*. 2006, Vol. 41 (6), p.1411-1420.
- [7] D. Marinkovic, A. Frey, I. Kuehne, G. Scholl. A New Rectifier and Trigger Circuit for a Piezoelectric Microgenerator. *Procedia Chemistry*. 2009, Vol. 1 (1), pp.1447-1450.
- [8] P. Li, Y. Wen, P. Liu, X. Li, C. Jia. A Magnetolectric Energy Harvester and Management Circuit for Wireless Sensor Network. *Sensors and Actuators A: Physical*. 2010, Vol. 157 (1), p.100-106.