



69th Conference of the Italian Thermal Machines Engineering Association, ATI2014

3D CFD TRANSIENT ANALYSIS OF THE FORCES ACTING ON THE SPOOL OF A DIRECTIONAL VALVE

Emma Frosina^{a,*}, Adolfo Senatore^a, Dario Buono^a,

^a*Department of Industrial Engineering, University of Naples Federico II, Via Claudio 21, Naples 80125, Italy*

Michele Pavanetto^b,

^b*Diplomatic Oleodinamica S.p.A., Via Mario Re Depaolini 24, 20015 Parabiago (MI) Italy*

Micaela Olivetti^c,

^c*OMIQ s.r.l., Via Lattuada 31, 20135 Milano, Italy*

Abstract

In this paper, a study of a hydraulic directional valve using a tridimensional fluid-dynamic approach will be shown.

During the valve spool displacement, the fluid-dynamics inside the valve creates forces who could reduce the valve performance.

The adopted methodology allowed the valve designer to study the complex fluid-dynamic behavior inside the valve and greatly help them to design the internal geometry with the objective of improving the valve performance.

This paper shows how a tridimensional fluid-dynamic approach can help engineers to develop the best valve geometry reducing the prototyping requirement and finally the time-to-market and, consequently, the development cost.

© 2015 The Authors. Published by Elsevier Ltd. This is an open access article under the CC BY-NC-ND license (<http://creativecommons.org/licenses/by-nc-nd/4.0/>).

Peer-review under responsibility of the Scientific Committee of ATI 2014

Keywords: 3D CFD and 1D Valve Model, Directional Valve

* Corresponding author. Tel. +39-081-768-32-85
E-mail address: emma.frosina@unina.it

1. Introduction

Nowadays, the goal of improving the efficiency of any mechanical or hydrodynamic system has become an essential requirement with the ultimate aim of reducing energy costs and therefore improve the environmental impact of our life. Consequently in a complex hydraulic system the efficiency of the various components is the first step to do towards this objective.

This paper is focused on the DS3 – TA directional valve by Duplomatic Oleodinamica S.p.A., designed in compliance with ISO 4401-03 (CETOP 03) standards to be mainly applied in industrial fields. Figure 1 shows a schematic cross section of the valve under study. The internal spool is stroked into the valve body by means of one solenoid and a spring on the other side. Table 1 summarizes the main valve characteristic.

Max. Operating Pressure Port: P, A, B	bar	350
Max. Operating Pressure Port: T	bar	210
Maximum Flow-Rate	l/min	100
Ambient Temperature Range	°C	-20 /+ 50
Fluid Temperature Range	°C	-20 /+ 80
Fluid Viscosity Range	cSt	10 ÷ 400
Recommended Viscosity	cSt	25

Tab 1. Directional valve characteristics

The Engine Hydraulic Research Group of the Department of Industrial Engineering at University of Naples “Federico II” developed this study using the 3D CFD code PumpLinx®, by Simerics Inc.®, focusing the main attention on axial flow forces.

With the aim of deeply understanding the internal fluid-dynamic behavior of the oil throughout a spool valve, it must be considered that its behavior is influenced mainly by two kind of forces: static and dynamic ones [3], [5], [7]. The static force is generated by the oil flow through the internal duct (This flow force is also referred to as Bernoulli force), while the dynamic force depends on oil pressure changes and spool position [1].

The zones near the ports connection area are smaller therefore fluid velocity is high [1], [2]. According to Bernoulli’s principle these regions of high velocity are also regions of low static pressure. In the following paragraphs a study of a directional valve will be presented.

The spool and core valve design has been modeled and analyzed using the CFD software package PumpLinx®[6]. The model were tuned and the results were validated using experimental data made on the hydraulic laboratory.

In the next sections, some details will be described more in detail and the comparisons between the experimental data and the simulation results will be shown.

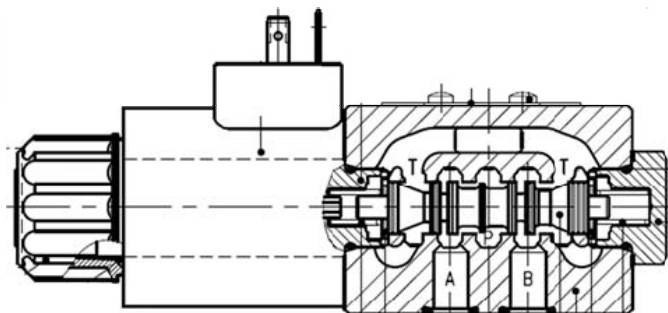

Fig 1. Schematic Cross Section of the Directional Valve

2. Directional Valve Model and Simulation

The directional valve has been simulated with the commercial CFD program PumpLinx[®] which solves numerically the fundamental conservation equations of mass, momentum and energy and includes accurate physical models for turbulence and cavitation [1].

From the directional valve 3D CAD geometry, the fluid volume was extracted, starting from the surfaces wet by the oil. The extracted volume is shown in figures 2 and 3; in particular, in figure 2 the entire internal valve fluid volume is shown while in figure 3 only the fluid volume inside the spool is shown.

 Simetrics

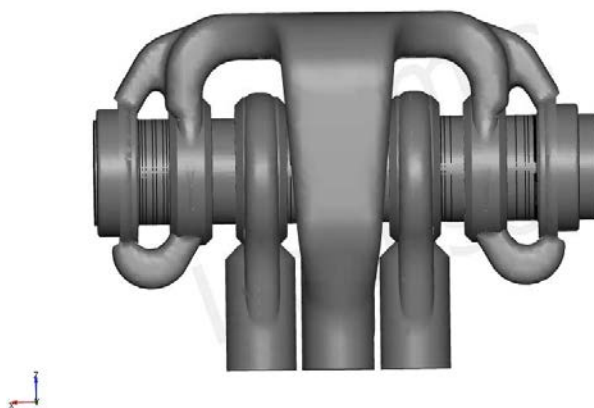

Fig. 2: Directional Valve Fluid Volume

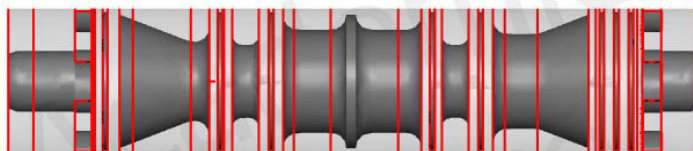

Fig. 3: Spool Volume

The obtained geometry was then meshed with the PumpLinx[®] grid generator.

Figure 4 shows the binary tree mesh in a section plane of the considered directional valve. In the boundary layer, the binary tree approach can easily increase the grid density on the surface without excessively increasing the total

cell count. In the regions of high curvature and small details, the grid was subdivided and cut to conform to the surface [2].

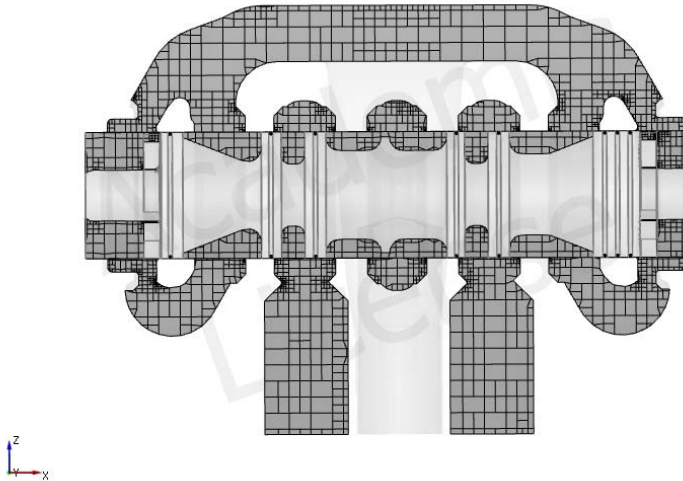

Fig.4: Binary Tree Mesh – Directional Valve Cross Section

The code allows for the simultaneous treatment of moving and stationary fluid volumes. Each volume connects to the others via an implicit interface.

First of all the model of the considered directional valve was made with a direct connection between ports A and B as shown in figure 5. This model consist of a 900.000 cells mesh.

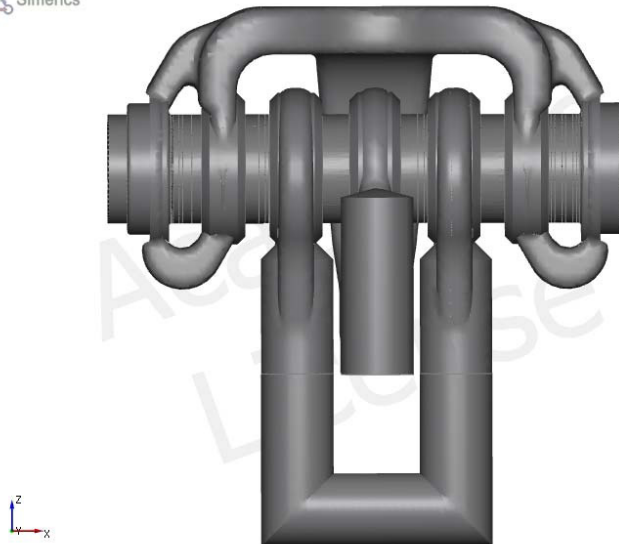

Fig.5: Valve Fluid Volume

The boundary conditions settled in the model were the same of the experimental one, particular:

- Oil temperature 40 °C
- Spool: P→A, P→B, A→T, B→T

The result of this analysis are presented in the following graph where the first comparison between experimental pressure drop and model results are show.

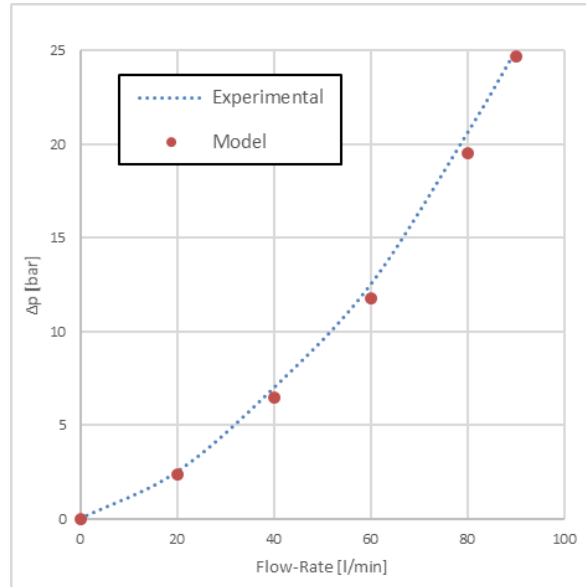

Fig. 6: Experimental/Model Comparison

The directional valve model results were compared with experimental data made by the valve manufacturer Duplomatic Oleodinamica S.p.A. on a hydraulic test bench.

The test were made at the oil temperature of 40°C T and with a Mobil DTE 25 (ISO VG 46) oil.

As already mentioned, the valve flow-rate operating limit is fixed at 100l/min; in this study, we decided to test also this worst case. In figure 7, the valve performance curve is shown; the pressure, for all flow-rate value, is always 350bar, the test was made on the hydraulic test bench shown in figure 8.

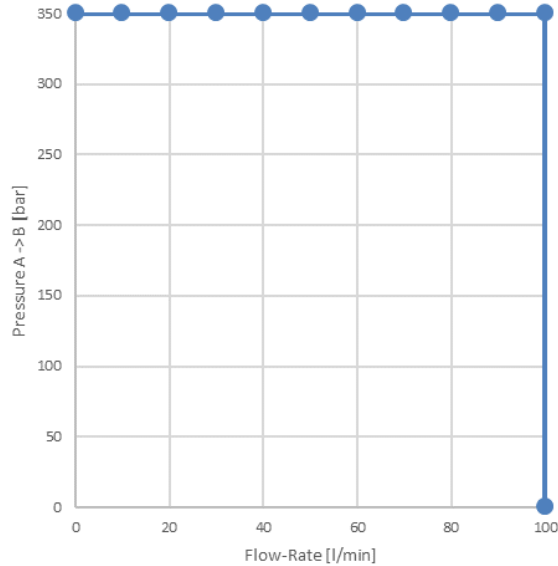

Fig. 7: Experimental Curve (P-Q)

The simulations were made to replicate experimental data (figure 7) simplifying the hydraulic test bench scheme in figure 8 with a variable restriction between ports A and B modelled inside the connection duct in figure 5. In

figure 9 the first model results in term pressure distribution in valve fluid volume of are shown. The following table shows the simulation operating conditions.

Pressure Port: A, B	bar	350
Pressure Port: T	bar	P_{atm}
Δp Port P \rightarrow A, B	bar	See figure 6
Δp Port B, A \rightarrow T	bar	See figure 6
Inlet Port P Flow-Rate	l/min	20
		40
		60
		90
Oil Temperature	$^{\circ}C$	40

Tab 2. Operating Conditions

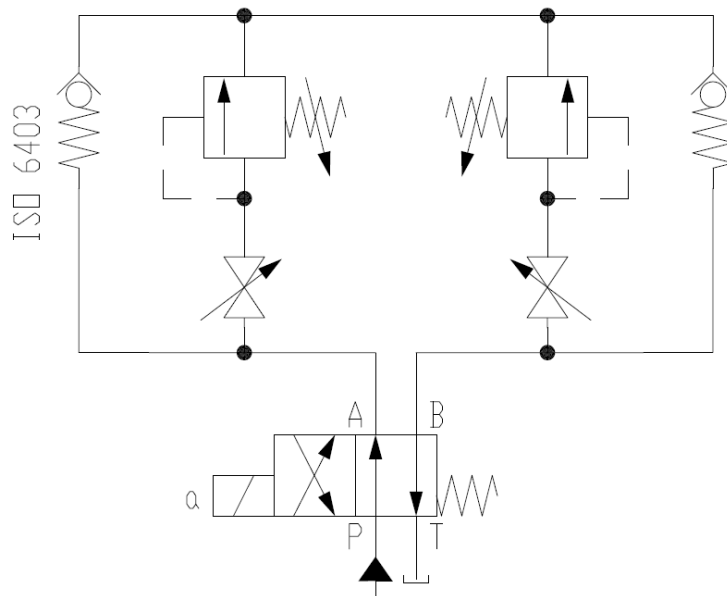

Fig.8: Test Bench Layout

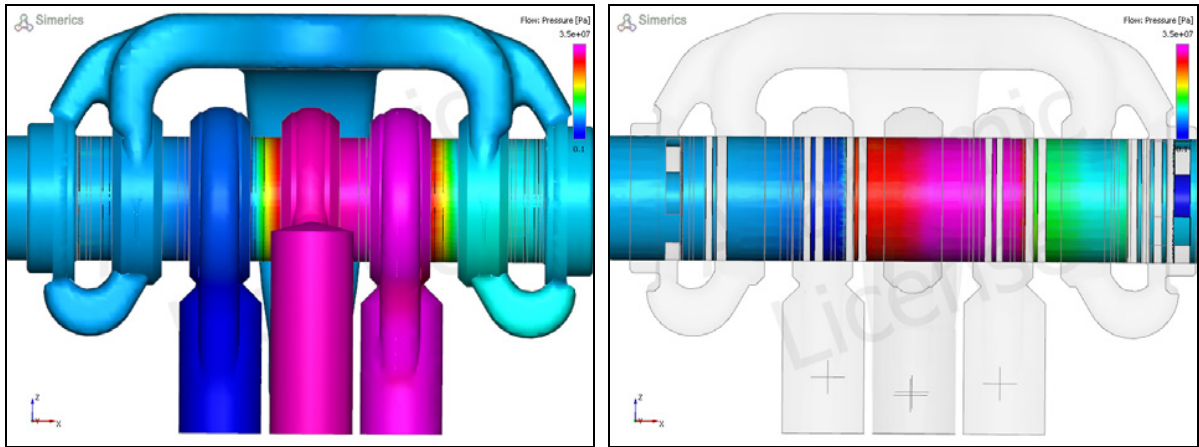

Fig. 9: Pressure Distribution in the Fluid Volume - P→A, B→T

In figure 9 the pressure varies between 350bar and atmospheric pressure, in this case port P is directly connected with port B. As already mentioned, the pressure drop between port B and port A is 350bar to replicate the experimental data in figure 7.

3. Model results

After the model build up and validation phases, all the simulation results were thoroughly analyzed in order to investigate the valve internal fluid forces behavior. This approach allows to study the internal force due to valve fluid-dynamics to find the possible system anomalies. For the next analyses the spool position will be moved from zero to 2.8mm. The valve position are shown in figure 10, where it was assumed:

- Position (1):
 - o Connection between Port P and A
 - o Connection between Port B and T
- Position (2):
 - o All ports close
- Position (3):
 - o Connection between Port P and B
 - o Connection between Port A and T

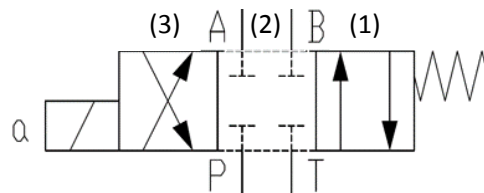

Fig. 10: Directional Valve Hydraulic Scheme

Figure 11 presents first valve model results in term of force vs spool displacement for different inlet port P flow-rate conditions, the graph show also the spool displacement variation as function of time for an actuation time of 100ms.

The boundary conditions for the model are:

- Oil inlet flow-rate at port P
- Port A and B: directly connected
- Atmospheric pressure at port T
- Actuation time: 100ms

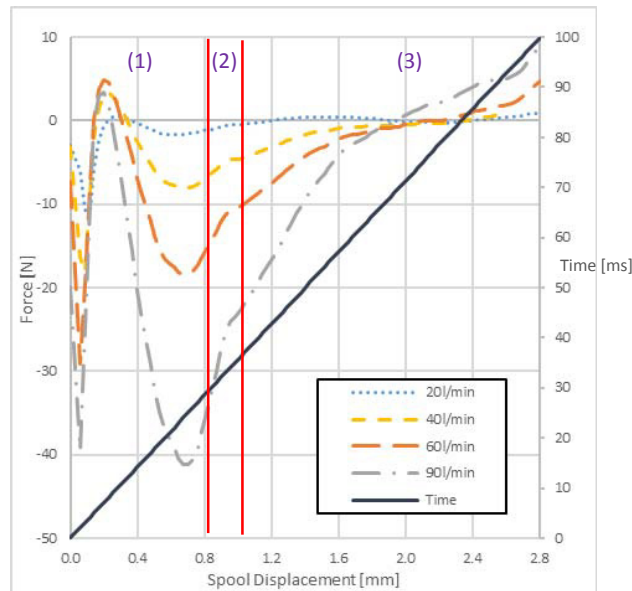

Fig. 11: Model Results – Force vs Spool Displacement

From the directional valve hydraulic scheme in figure 10, it can be noted that the force value during the spool displacement is mainly negative in the first position (position 1 in figure 10), becomes minimum in central position (position 2 in figure 10) and increases in the last position (position 3 in figure 10). For this operating conditions, the forces value varies between +10N and -40N. The curves trend is the same for all port P flow-rate input.

Negative forces are in opposition of solenoid operation, while positive forces are in spring contrast.

Figure 12 shows flow streamlines colored by the fluid velocity for a spool displacement:

- 0.2mm, spool in position (1)
- 0.8mm, spool in position (1)
- 1.01mm, spool in area between position (1) and position (2)
- 2.6mm, spool in position (3)

It is important to underline that the spool positions at 0.2mm and 0.8mm means connection between port P→A and B→T, at 0.9mm the spool is in the configuration (2), at 1.07mm the spool passes in the third position connection between port P→B and A→T. As mentioned above, the last phase (3) starts at 1.08mm and ends at 2.8mm (maximum displacement).

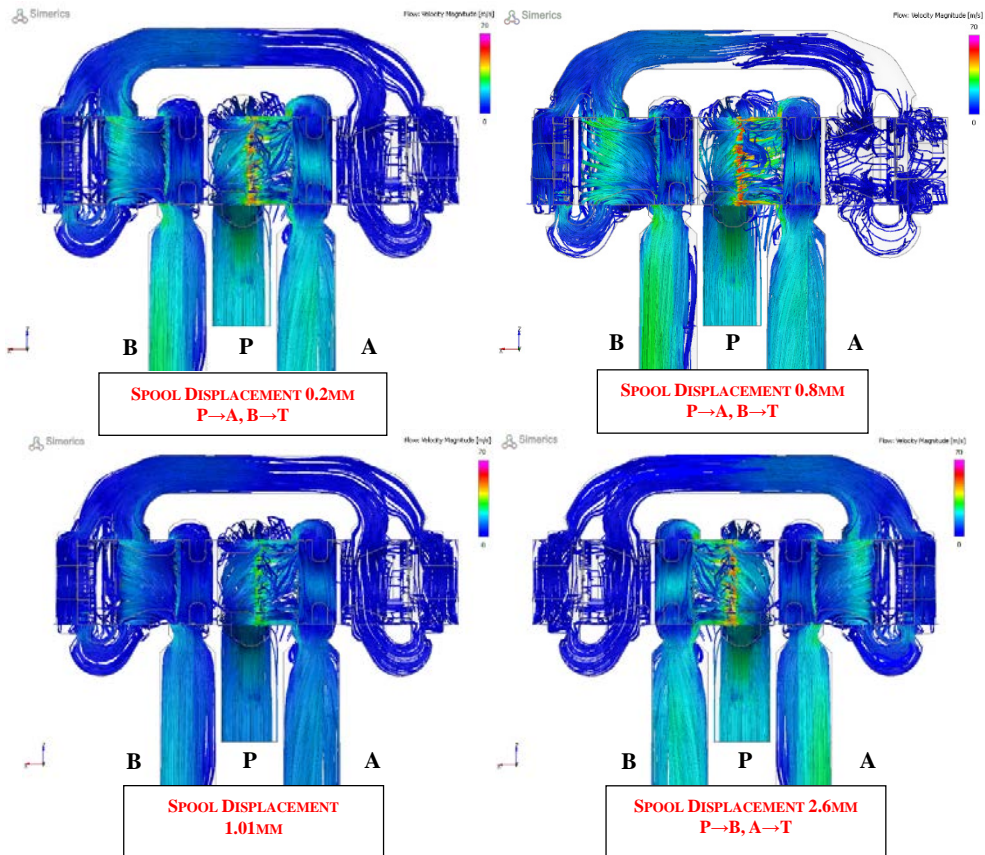

Fig. 12: Typical streamlines Colored by Velocity Magnitude Inside the Valve Fluid Volume for Three Different Spool Position, 60l/min

Figure 12 shows that velocity values vary with spool displacement in few fluid volume areas, for example passing through the first to the last one the fluid velocity values vary in the area between ports P and A and in port B initial duct. These phenomena may influence the force values and could cause the high force oscillations in these spool positions.

This hypothesis was confirmed comparing figure 12 with graph in figure 11: for a displacement of 0.2 [valve position (1)] the high flow velocity causes the positive force spikes while for a displacement of 0.8 [area at the end of valve position (1)] fluid velocity causes a fast forces reduction in opposition of solenoid operation.

The previous analysis was made in the following operating conditions:

- Oil inlet flow-rate at port P
- $\Delta p_{A-B} = 350 \text{ bar}$
- Atmospheric pressure at port T
- Oil temperature 40 °C
- Actuation time: 100ms

Valve model results are shown in figure 13.

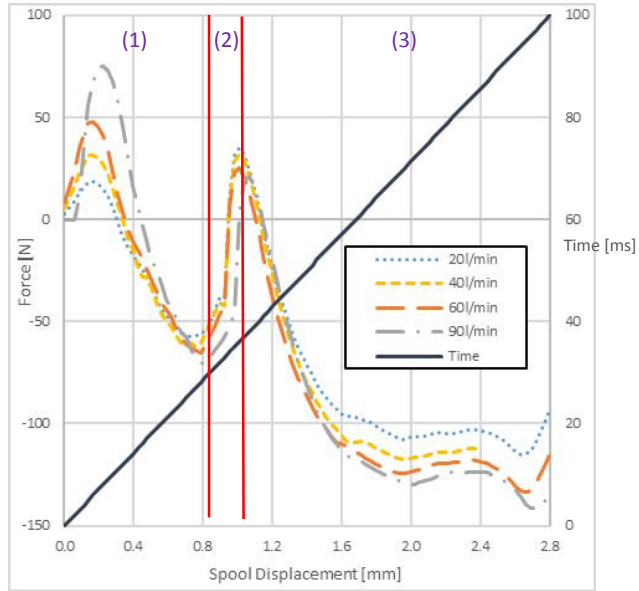
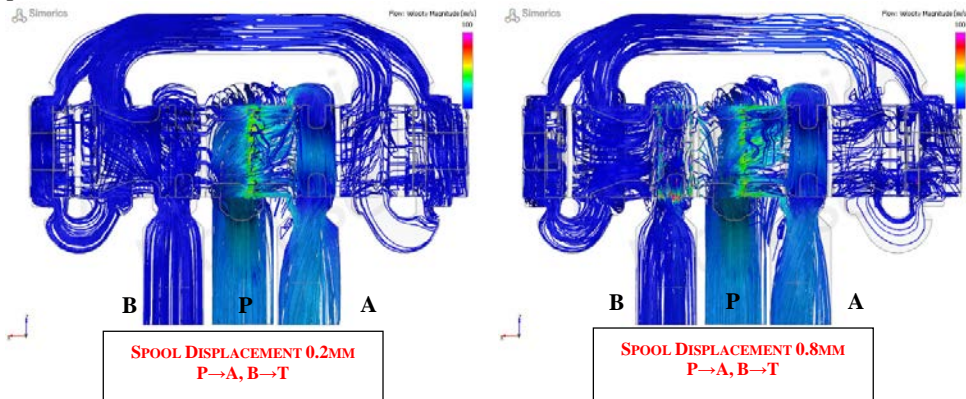

Fig. 13: Model Results – Force vs Spool Displacement

Comparing the graphs in figures 11 and 13 it can be noted that force oscillations increase as a result of worse valve operation conditions but the trend confirms the critical spool positions (1) and (2) .

In that case there are two positive force spikes in the first and second positions (position 1 and 2 in figure 10), then force values become negative in the last position (position 3 in figure 10). Analyzing figure 13, it can be noted that the first and third graph areas were function of port P flow-rate inlet while this is not true for the second one. In particular the first maximum passes from +10N (inlet flow-rate of 20l/min) to +72N (inlet flow-rate of 90l/min).

As shows in figure 11, the following pictures (figure 14) show the streamlines colored by the fluid velocity for the same spool positions.



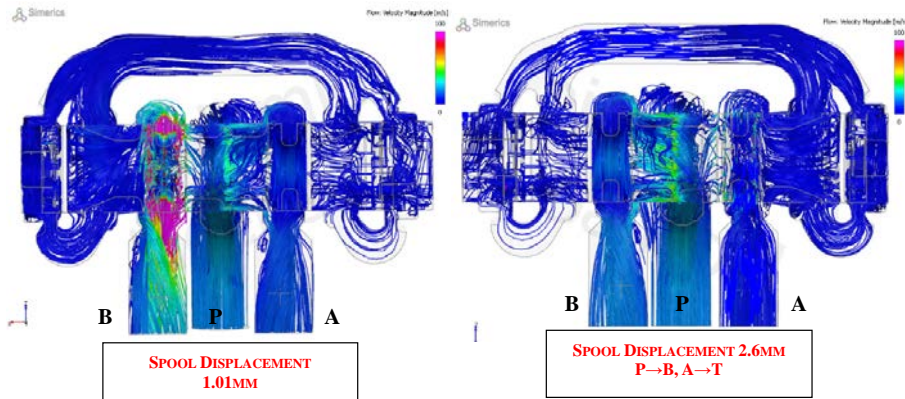

Fig. 14: Typical streamlines Colored by Velocity Magnitude Inside the Valve Fluid Volume for Three Different Spool Position, 60l/min

Figure 14 shows few interesting fluid-dynamics phenomena, for example the magenta streamlines inside port B (third picture in figure, spool displacement: 1mm) cause the second positive force spike in figure 12. As already mentioned, the spool positions at 0.2mm and 0.8mm imply a connection between port P→A and B→T, at 0.9mm the spool is in the configuration (2) and at 1.07mm the spool passes in the third position connection between port P→B and A→T.

Starting from these model results the next steps will be to design a new directional valve internal geometry with the objective to reduce the fluid-dynamic forces (figures 13 and 11). The study will allow to choose solenoid and spring based on the force evolution during the spool displacement.

4. Conclusions

In this paper a tridimensional approach to model a new directional valve core was presented.

The tridimensional model results were validated with experimental data obtained on an appropriate test bench of the valve manufacturer Duplomatic Oleodinamica S.p.A.

The possibility to operate with a tridimensional code, particularly suitable for this type of application, can offer the opportunity to achieve good results in a very short computational time.

The validated valve model was used to study the fluid-dynamic force and to find some critical spool positions.

The model results proved that few critical fluid-dynamic areas should be redesigned to reduce the force value; and to optimize the directional valve performance.

References

- [1] A. Senatore, D. Buono, E. Frosina, M. Pavanetto, I.J. Costin, M. Olivetti, "Improving the position control performance of a Proportional spool valve, using a 3D CFD modeling", IFPE Las Vegas, paper nr 29.2, 2014.
- [2] E. C. Fitch, I. T. Homg "Hydraulic Component Design and Selection" Oklahoma : Baryne.Inc, 2004, ISBN 0970592256.
- [3] D. S. Weaver, F. A. Adubi, N. Kouwen, "Flow Induced Vibrations of a Hydraulic Valve and Their Elimination", J. Fluids Eng. 100(2), 239-245 (Jun 01, 1978), doi:10.1115/1.3448639
- [4] Guillermo Palau-Salvador, Pablo González-Altozano, Jaime Arviza-Valverde, "Three-Dimensional Modeling and Geometrical Influence on the Hydraulic Performance of a Control Valve" J. Fluids Eng. 130(1), 011102 (Dec 19, 2007), doi:10.1115/1.2813131
- [5] M. D. Ramesh, Y. A. Tan, X. Lan, "Optimization of a Hydraulic Valve Design Using CFD Analysis", 2005 SAE Commercial Vehicle Engineering Conference, SAE paper n° 2005-01-3633, DOI 10.4271/2005-01-3633
- [6] R. Yang, "Predicting Hydraulic Valve Pressure Drop Using CFD", 2005 SAE Commercial Vehicle Engineering Conference, SAE paper n°2005-01-3635, DOI 10.4271/2005-01-3635
- [7] R. Miller, Y. Fuji, J. McCallum, G. Strumolo, W. Tober, C. Pritts, "CFD Simulation of Steady-State Flow Forces on Spool-Type Hydraulic Valves", 1999 SAE International Congress & Exposition, SAE paper n° 1999-01-1058, DOI 10.4271/1999-01-1058

Contact information

Emma Frosina

Department of Industrial Engineering, University of Naples Federico II - Via Claudio 21, Naples, Italy

emma.frosina@unina.it

www.dii.unina.it