



69th Conference of the Italian Thermal Engineering Association, ATI 2014

Utilities Substations In Smart District Heating Networks

M. A. Ancona^{a,*}, L. Branchini^b, B. Di Pietra^c, F. Melino^a, G. Puglisi^c, F. Zanghirella^c

^a *DIN – Alma Mater Studiorum Università di Bologna – Viale del Risorgimento 2 - 40136 Bologna*

^b *CIRI EA – Alma Mater Studiorum Università di Bologna – Viale del Risorgimento 2 - 40136 Bologna*

^c *Unità Tecnica Efficienza Energetica – ENEA – Via Anguillarese 301 - 00123 Roma*

Abstract

In the last decades the concept of distributed generation – *i.e.* the installation of (electrical and/or thermal) energy production systems at the final users – was born and found gradually increasing diffusion. For what concerns the electrical production, the distributed generation systems are directly connected to the National Electricity Transmission Grid, allowing a bidirectional energy flux at the utilities and giving rise to the so-called smart grid.

In this scenario and considering that, even thanks to the direction taken by European regulations, in the European territory there is already a large number of thermal power generation's distributed systems (*e.g.* solar thermal panels), in the near future the concept of smart grid could be extended to the heat sector, especially in relation to District Heating Networks (DHNs). As a consequence, with the aim of analyzing the penetration of this type of networks, several possible layouts for the exchange utilities' substation have been developed and will be presented in this study. Such layouts allow to optimize thermal exchange, as a function of network design temperatures (for both the supply and the return), of utilities' thermal power requirement and depending on the characteristics of the production system.

© 2015 The Authors. Published by Elsevier Ltd. This is an open access article under the CC BY-NC-ND license (<http://creativecommons.org/licenses/by-nc-nd/4.0/>).

Peer-review under responsibility of the Scientific Committee of ATI 2014

Keywords:

* Corresponding author. Tel.: +39 051 209 33 20; fax: + 39 051 209 33 13.
e-mail address: maria.ancona2@unibo.it

1. Introduction

With the aim of obtaining several advantages, with regard to either practical or environmental and safety aspects, the direct production of thermal energy for hot water and space heating can be replaced with the district heating.

Usually, in District Heating Networks (DHNs) the production of heat is centralized and the network is crossed by hot water or steam, ranging from 90 to 130°C [1].

Nowadays, in Italy DHNs are installed in 109 cities for a total of 148 systems and a connected volumetry of 279'400'000 m³ [2]. Figure 1 shows the increase of connected DHN volumetry since 1972 to 2012.

Actually, the thermal energy provided is about 8'106 GWh, combined with 5'592 GWh of electrical energy. In this scenario, District Heating (DH) allows to save 439'518 toe and avoid about 1'433'537 ton of CO₂ emissions [2]. The comparisons, in terms of primary energy and emissions of CO₂, between traditional production systems and systems in the service of DHNs are shown respectively in Figure 2 and Figure 3.

As well known, the European strategy 20-20-20 [3] promotes the increase of energy efficiency, the reduction of fossil fuel consumption and the reduction of emissions. In this scenario, the energy and environmental benefit represented by DHN can be further enhanced with the concept of Smart District Heating Network (SDHN).

Smart district heating network replies, in heat sector, the concepts of distributed generation and of energy exchange between a prosumer (*i.e.* a producer and consumer of energy) and the grid, already known for the electrical sector.

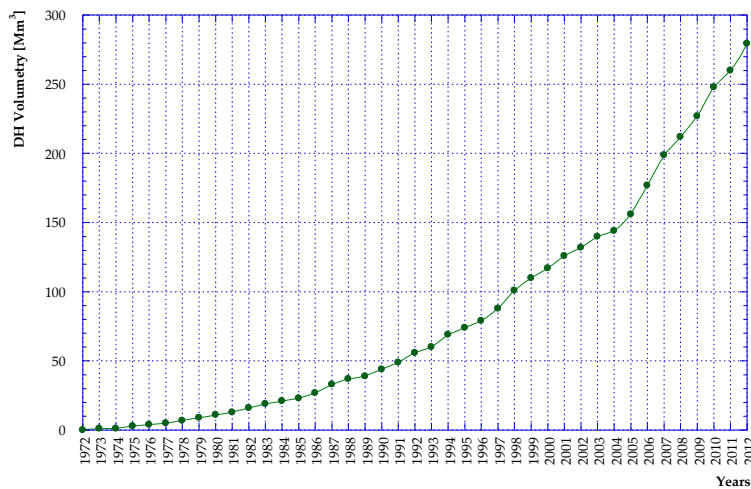

Figure 1 - Trend of DHN volumetry in Italy between 1972 and 2012 [2]

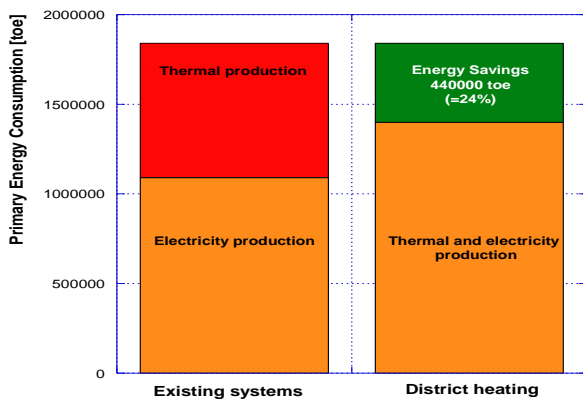

Figure 2 – Fossil primary energy savings with DHNs [2]

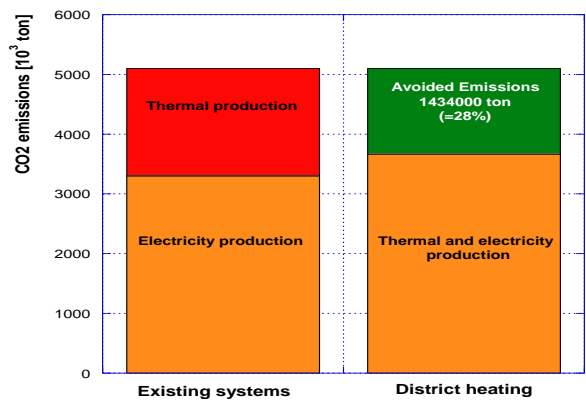

Figure 3 – CO₂ emissions [2]

Examples of SDHNs can be found in Central and Northern of Europe, such as in Sweden, Denmark [4], etc.; in particular, the distributed generation systems in these smart networks are often thermal solar generators.

In this respect, it can be seen that, during the winter period, the solar generator satisfies only a fraction of the thermal energy need of the utility: the remaining part has to be supplied by the thermal distribution network. On the contrary, during the summer, it usually occurs that the solar production overcomes the thermal need: in this case the excess of production can be sold to the distribution network. It follows a bidirectional exchange of thermal energy between the distribution network and the utility. In this case, the network can be used as seasonal storage; of course this can increase the efficiency of the whole system.

Obviously, also the cogeneration units can be used as decentralized thermal production systems in SDHNs. The only constraint to the bidirectional exchange regards the temperature at which the decentralized system produces the thermal energy with reference to the temperature of distribution network.

For this reason, Combined Heat and Power (CHP) units, such as micro-turbines and internal combustion engines, can be easily integrated with DHN.

On the contrary, other systems such as micro Rankine cycles, solar thermal plates and Stirling engines could be characterized by a thermal production at temperature levels lower than the typical values of DHN. In this case the integration can occur only with particular configurations and/or under certain boundary conditions, as will be better explained below.

2. Smart district heating substations

Utilities substations are one of the most important components in a district heating system, because they represent the transfer of thermal energy from the grid to the utilities. Generally, the transfer of energy from the grid to the users (and simultaneously the control strategy of a district heating network) can occur in two distinct criteria: with a constant mass flow rate and variable ΔT (*i.e.* the temperature difference between the inlet flow from the supply circuit and the outlet towards the return circuit) or with a variable mass flow rate and constant ΔT .

In case of bidirectional exchange of thermal energy between the network and the utility, the configuration of the traditional substation needs to be radically changed.

Theoretically, four different configurations, as presented in Figure 4, can be considered:

- scheme 1 (supply to return): in this scheme the mass flow rate from the supply of the network is heated by decentralized production system before the reintroduction in the return circuit;
- scheme 2 (supply to supply): this configuration is connected only with the supply circuit for what concerns the thermal energy exchange from the decentralized production system towards the distribution network;
- scheme 3 (return to return): in this case, the introduction of thermal energy from the utility to the network occurs only acting on the return circuit;
- scheme 4 (return to supply): this is the more complex scheme, because the feed-in flow is taken from the return circuit, heated from the decentralized production system and reintroduced in the supply of the network.

From the four schemes it can be seen that three different circuits can be defined: the primary circuit, which connects the distribution network to the substation; the secondary circuit, which is internal to the utility and, finally, the tertiary circuit, which exchanges the heat produced by the decentralized system.

All the proposed schemes, are designed to introduce into the distribution network only the excess of thermal production. In other words, the regulation strategy requires that the produced thermal power is firstly used for the utility needs (HX-TS heat exchanger in Figure 4): if the utility thermal needs is not completely satisfied from the production system, the distribution network provides the residual heat (HX-PS heat exchanger in Figure 4); on the contrary, if an excess of production occurs and the tertiary residual temperatures are suitable, the introduction of heat into the network can be realized (HX-TP heat exchanger in Figure 4).

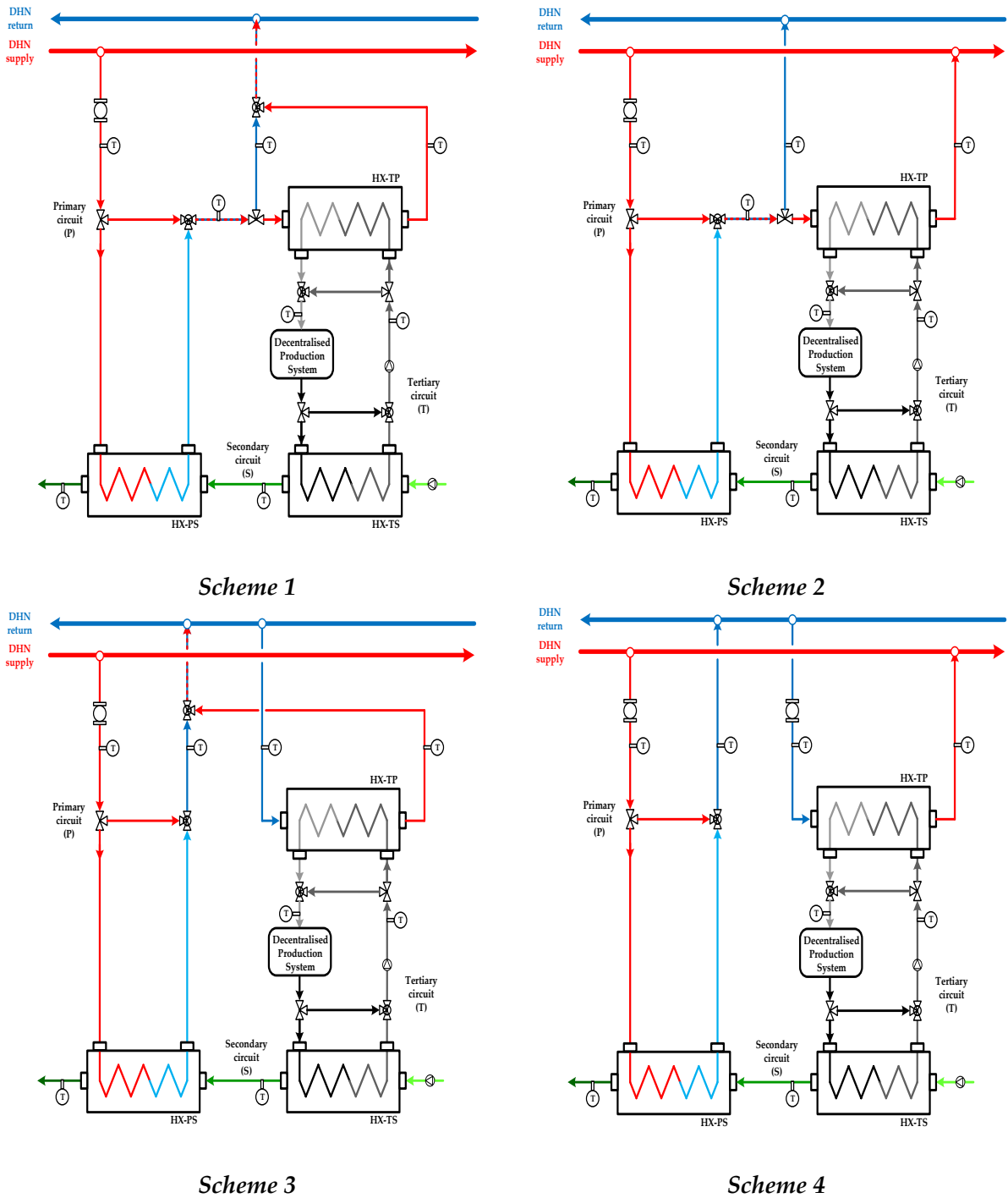

Figure 4 – Hydraulic integration of decentralized production systems: scheme 1 – supply to return; scheme 2 – supply to supply; scheme 3 – return to return; scheme 4 – return to supply

It can be also observed that schemes 1 and 3 are rarely adopted because they involve the increase of temperature of the return circuit of distribution network. This is often not appreciated for the network management because the

increase of temperature of the return flow in the central production system implies a change in control and regulation strategy of the whole network; further, the conversion efficiency of the central production systems decreases due to the necessary regulation.

On the other side, scheme 2 implies the increase of the supply circuit temperature; depending on the regulation strategy of the network, this increase could not be optimal for utilities which need a constant temperature flow and/or for others decentralized systems which can be excluded from the possibility of thermal energy feed-in.

Finally, scheme 4 is the only one which modifies the current flow of the network, due to the flow from the return to the supply of the network. As can be seen from Figure 4, this scheme do not necessary implies the increase of the supply temperature; this evidence means that, for what concerns the temperature profile of the network, the presence of smart substations does not cause particular regulation problems. For instance, scheme 4 is widely adopted in existing SDHNs.

3. IHENA Software description

In order to estimate the performance of a SDHN, a calculation code has been developed by University of Bologna. This software, called IHENA (Intelligent Heat Energy Network Analysis), is based on the Todini-Pilati algorithm [5] generalized by the use of Darcy-Weisbach equation. This software derives from Ca.R.Di.F. 5.1 [6] and represents an evolution in order to take into account the bidirectional exchange of thermal energy with reference to the substation schemes in Figure 4. The calculation code validation can be found in [7].

The IHENA flow chart is presented in Figure 5 and shows the main connections between required inputs, calculation routines and outputs.

More in details, the flow chart can be divided into six main sections:

- 1) network implementation: this section concerns the introduction of the main input of network geometry, such as nodes coordinates and typology (mixer, utility, source), pipes length, utilities schemes, etc.;
- 2) network input: in this section the main network input, such as source temperature, source pressure and utility's thermal demand, etc., can be introduced;
- 3) utilities fitting: this routine realizes the balance among the decentralized thermal production system (in case of smart substations), the utility needing and the network feeding. This balance represents the first attempt solution of the calculation code;
- 4) network geometry implementation and operational parameters definition: this is the routine which, on the basis of the previous input, draws the network and allows the definition of the regulation strategy (*i.e.* constant mass flow rate, constant temperature difference or a mix of this two regulation criteria)
- 5) network calculation: in this routine the Todini-Pilati algorithm is applied in order to calculate temperatures, pressures and mass flow rates of the whole network, including the bidirectional exchange with the smart utilities;
- 6) text and graphical output: this section only provides to the writing of the output in both text and graphical form.

Network inputs and operational parameters have to be defined for both the supply and the return circuit. In this connection, it is important to point up that the software, once defined a supply layout of the network, considers the same geometry for the return, simply reversing the direction of the flow. Thus, the nodes that for supply are sources for the return are considered as “virtual” utilities; in the same way, the utilities are considered as “virtual” sources, while the mixers remain the same.

The outputs of the software are, for both supply and return of the DHN, among the others:

- inlet and outlet temperature and pressure, mass flow rate, velocity, pressure drop for each pipe;
- total mass flow rate supplied from the sources;
- total electrical power for the pumping stations;
- pressure drops at each of primary circuits of the utilities;
- heat exchanged between network and utilities.

Moreover, the developed software enables to visualize the network's layout, both for the supply and for the return, with pointers on each pipe to indicate the direction of flow.

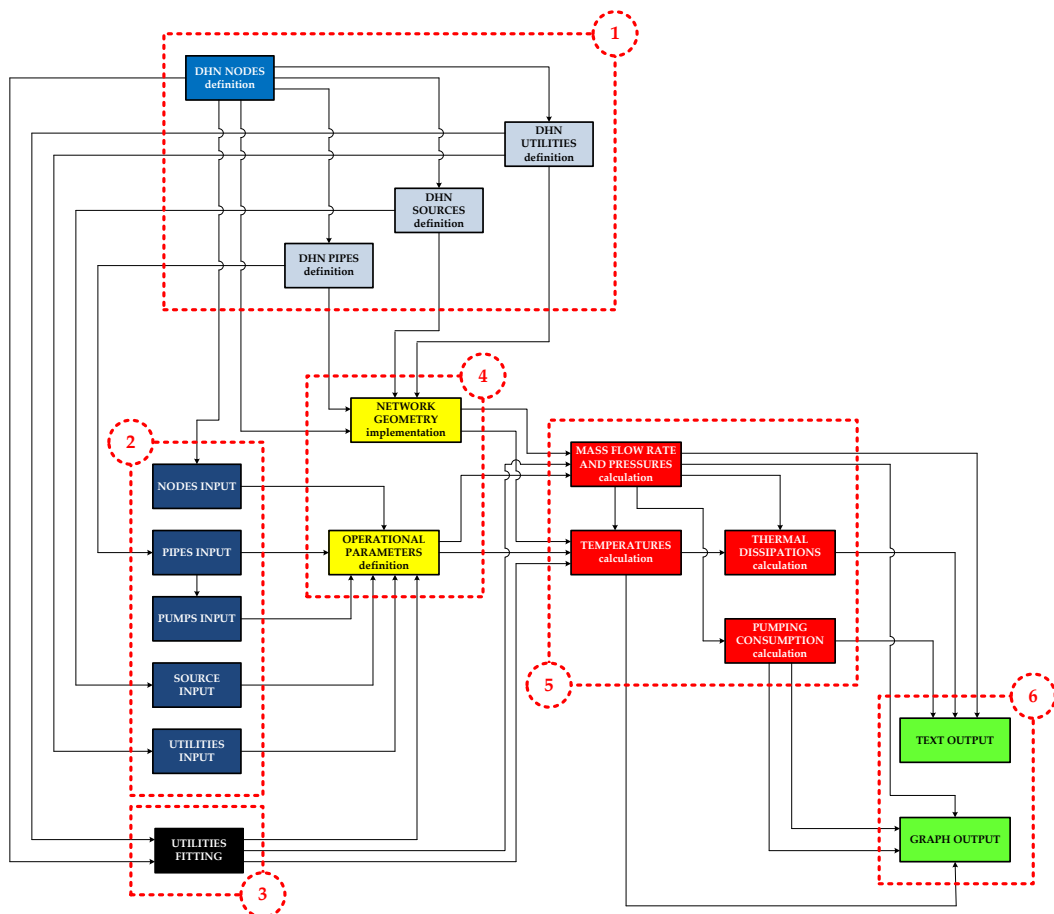

Figure 5 – IHENA software main flow chart

With the software IHENA, finally, it is possible to calculate and graph the distributions of velocity, mass flow rates, pressure losses and diameters. The understanding of the representation is immediate, thanks to the use of different colors for the different ranges of the considered quantity.

This software can be used for design of new networks or for performance analysis and optimization of existing networks. More in details, the optimization is developed by the use of a trial and error procedure [6].

4. Simulations

A series of simulations have been carried out in order to analyze the behavior of smart substations. More in detail, a parametric analysis has been conducted by varying the ratio between the users need ($Q_{TH,U}$) and the thermal power

($Q_{TH,SP}$) available from the decentralized production system. Moreover, a variation of the ratio between the flow rate circulating in the primary circuit (M_P) and that circulating in the tertiary (M_T) has been considered.

The ratio $Q_{TH,U}/Q_{TH,SP}$ has been exclusively considered ranging between 0 and 1: it means to take into account only the case in which the thermal power provided by the production system exceeds the user's needs as described before regarding the control strategy of the smart substations.

Further, the following boundary conditions have been assumed:

- temperature of the supply circuit of the network equal to 80 °C or to 90 °C;
- temperature available from the production system (input tertiary circuit) equal to 110 °C.

It should be noted that a supply temperature ranging from 80 to 90 °C is typical and largely adopted for DHNs, especially in the South of Europe. As a consequence, the production system available temperature has been chosen equal to 110 °C in order to guarantee a suitable temperature difference with the supply circuit of distribution network. A temperature equal to 110 °C can be achieved with systems such as internal combustion engines, micro-turbines, among CHP units, or with vacuum thermal panels.

The results of the developed simulations are presented in Figures from 6 to 11 in terms of primary circuit temperature increase versus the ratio $Q_{TH,U}/Q_{TH,SP}$. In particular, in Figures 6, 8 and 10 the temperature increase is shown as function of M_P/M_T (varying from 0.5 to 2.0) with reference to a supply temperature of 80 °C, while in Figures 7, 9 and 11, the comparison between two different supply temperature respectively equal to 80 °C and 90 °C is considered, being constant the value of M_P/M_T (equal to 1.0).

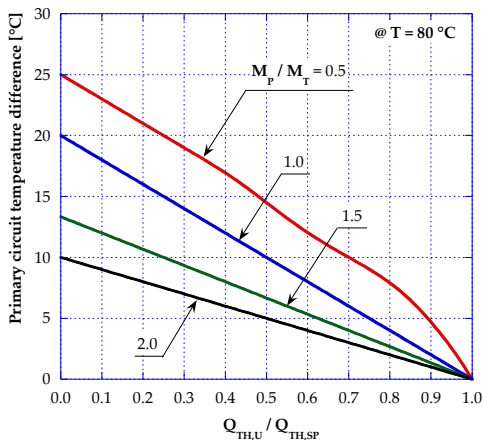

Figure 6 – Primary circuit temperature change @T=80 °C in case of schemes 1 and 2

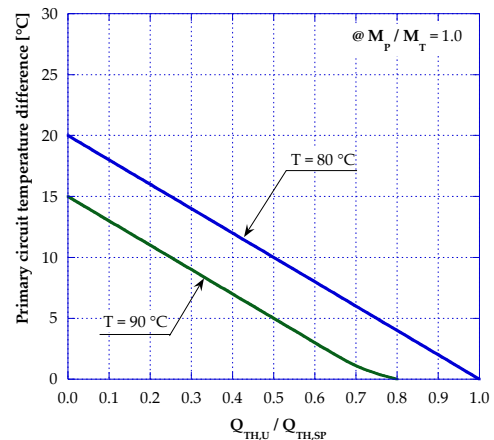

Figure 7 – Primary circuit temperature change @ $M_P/M_T=1.0$ in case of schemes 1 and 2

It should be noted that the presented results relate only to the temperature variations of the primary circuit, without considering the effect on the main network temperatures which, in this analysis, has not been investigated.

From the figures, it can be observed that the results for schemes 1 and 2 coincides. This evidence is due to the fact that both the configuration are characterized by the heat exchanger HX-TP fed from the supply circuit of the network. On the basis of the assumed hypothesis and boundary conditions, the maximum increase of temperature of the primary circuit is equal to about 25 °C for a supply temperature of 80 °C. With the increase of supply temperature to 90 °C, the maximum increase reduces to 15 °C. Obviously, with the increase of the ratios M_P/M_T and/or $Q_{TH,U}/Q_{TH,SP}$ the achievable temperature differences decreases.

Passing to the scheme 3, it can be seen that the achievable temperature increases are higher on the respect of schemes 1 and 2, because it acts on the return circuit flow.

Finally, the curves related to the scheme 4 derives from the ones of scheme 3 – for the same reasons already explained in case of schemes 1 and 2 – but with a reduced range of the ratio $Q_{TH,U}/Q_{TH,SP}$. The limitations are due to the temperature levels: in fact in scheme 4 the heated mass flow rate has to be introduced on the supply of the network.

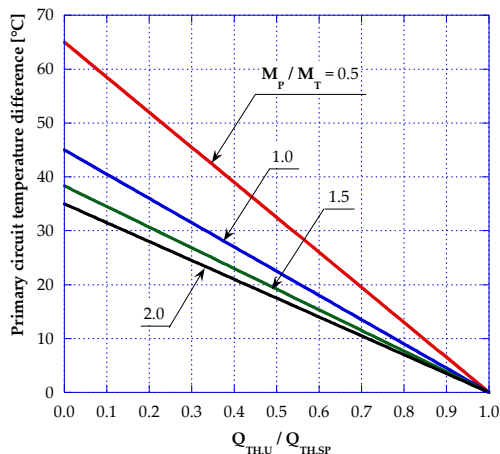

Figure 8 – Primary circuit temperature change @T=80 °C in case of scheme 3

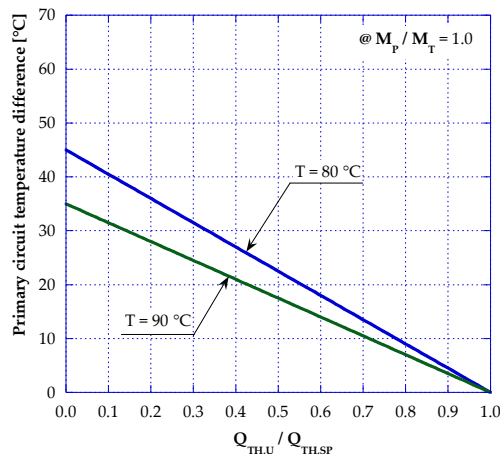

Figure 9 – Primary circuit temperature change @M_P/M_T=1.0 in case of scheme 3

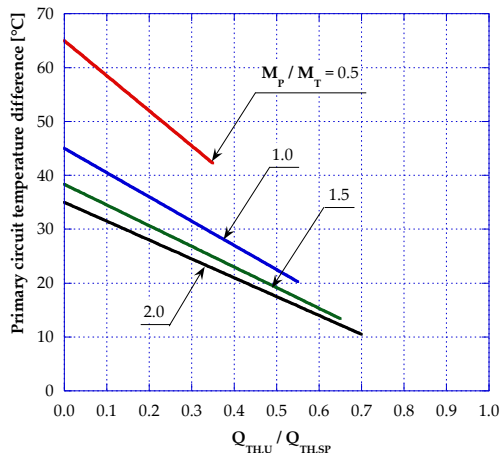

Figure 10 – Primary circuit temperature change @T=80 °C in case of scheme 4

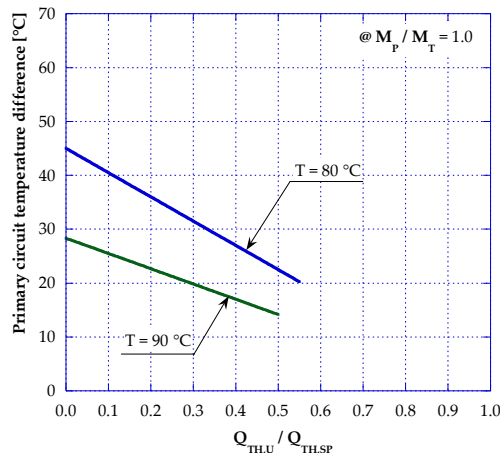

Figure 11 – Primary circuit temperature change @M_P/M_T=1.0 in case of scheme 4

The results presented in this paper have been obtained as part of a research activity developed by the University of Bologna in collaboration with ENEA (National Agency for New Technologies, Energy and Sustainable Economic Development). These results provide a preliminary analysis on utilities substations in SDHNs, with the aim – for the future – of extending the study on the behavior of a DHN with bidirectional heat exchange and of analyzing the penetration ability of these types of network.

5. Concluding remarks

Smart district heating networks can play a key role for the increase of the efficiency for the end-users. In particular, SDHNs allow to extend the concept of distributed generation to the heat production, distribution and use. With this approach, a DHN can be used as a storage system in order to increase the fuel utilization factor, in case of CHP units, or to maximize the exploitation of renewable sources.

Considering this new concept of DH, utilities substations play a primary role for what concerns the heat exchange between the network and the utilities. In this preliminary study, four substations able to exchange heat in a bidirectional way with a distribution network are presented, simulated and discussed.

In order to study SDHNs, a new software, called IHENA (Intelligent Heat Energy Network Analysis), has been developed by University of Bologna. This calculation code has been applied to simulate the behavior of the four smart substations which have been defined. The main results put in evidence the change of temperature of supply and/or of return circuits. These variations need to be further investigated with a deeper technical and economic analysis, with the aim of understanding the optimum regulation and operational strategy for both the source and the utilities side.

Nomenclature

| | |
|-------------|--|
| CHP | Combined Heat and Power |
| DH | District Heating |
| DHNs | District Heating Networks |
| HX-PS | Heat Exchanger between the primary and the secondary circuits |
| HX-TP | Heat Exchanger between the tertiary and the primary circuits |
| HX-TS | Heat Exchanger between the tertiary and the secondary circuits |
| M_P | Mass flow rate circulating in the primary circuit |
| M_T | Mass flow rate circulating in the tertiary circuit |
| $Q_{TH,SP}$ | Thermal power produced by the decentralized production system |
| $Q_{TH,U}$ | Utility's Thermal Need |
| SDHN | Smart District Heating Network |

References

- [1] – Annuario Associazione Italiana Riscaldamento Urbano – 2011
- [2] – Annuario Associazione Italiana Riscaldamento Urbano – 2013
- [3] – Directive 2009/28/EC of the European Parliament and of the Council of 23 April 2009 on the promotion of the use of energy from renewable sources and amending and subsequently repealing Directives 2001/77/EC and 2003/30/EC (Text with EEA relevance)
- [4] – Schafer K, Schlegel F, Pauschinger T, “Decentralized feed-in of solar heat into district heating networks – a technical analysis of realized plants”, Book of papers of the 2nd International Solar District Heating Conference, 3-4 June 2014, Hamburg, Germany.
- [5] – Todini E, “Towards Realistic Extended Period Simulations (EPS) In Looped Pipe Networks”, Proceedings of 8th Annual Int. Symp. On Water Distribution Systems Analysis, ASCE, Reston, VA; 2006.
- [6] – Ancona MA, Melino F, Peretto A, “An Optimization Procedure for District Heating Networks”, Proceedings of International Conference on Applied Energy – ICAE 2014 – May 30, June 2, 2014, Taipei, Taiwan
- [7] – Ancona MA, Bianchi M, Branchini L, Melino F, “District Heating Network Design And Analysis”, *Energy Procedia*; Volume 45, 2014, Pages 1225-1234.