



International Conference on Industry 4.0 and Smart Manufacturing (ISM 2019)

## An RFID application for the process mapping automation

Orazio Urso <sup>(a)</sup>, Ferdinando Chiacchio <sup>(a)\*</sup>, Lucio Compagno <sup>(a)</sup>, Diego D'Urso <sup>(a)</sup>

*"Department of Electrical, Electronic and Computer Engineering, University of Catania"*

\* Corresponding author. Tel.: +39-095-7382412 ; E-mail address: [chiacchio@dmi.unict.it](mailto:chiacchio@dmi.unict.it)

### Abstract

Despite the extraordinary progresses that technology has brought in the automation of the production systems, Business Process Mapping, and in particular the automation of this important activity, represents a relevant example of methodology that can still take advantage of this new trend.

In this paper, a RFID toolkit developed to aid with the Business Process Mapping is presented. The main concept of Business Process Mapping and of the RFID technology are summarized. Afterwards, the RFID toolkit architecture and its features are discussed.

In order to test the capability of the proposed toolkit, a case of study of a pharmaceutical company has been analysed. The relevant lead times characterizing the main phases of the production cycles are tracked and the flow diagram of the production process has been automatically mapped.

© 2020 The Authors. Published by Elsevier B.V.

This is an open access article under the CC BY-NC-ND license (<http://creativecommons.org/licenses/by-nc-nd/4.0/>)

Peer-review under responsibility of the scientific committee of the International Conference on Industry 4.0 and Smart Manufacturing.

*Keywords:* Business Process Mapping; RFID & IOT; production processes; decision support system; performance evaluation

### 1. Introduction

Process Mapping (BPM) is a technique of Business Process Management that aims at analyzing how a business process works [1]. BPM attempts to provide a visual display of the steps characterizing a production process, identifying the actors, human personnel and machines, and the relationships that contribute to the realization of a business goal [2].

The first definition of BPM can be dated back to 1921 when Frank Gilbreth presented the flow process chart, the first structured method for documenting process flows. Gilbreth's tools were quickly integrated into industrial engineering curricula and in 1947, the American Society of Mechanical Engineers (ASME) adopted a symbol set derived from Gilbreth's work, conceiving the ASME Standard for Process Charts [3].

Business process mapping, also known as process charts, has become much more prevalent and understood in the

business world in recent years. Process maps can be used in every section of life or business to aid to:

1. process identification - identify objectives, scope, players and work areas;
2. information gathering - gather process facts (what, who, where, when) from the people who do the work;
3. process mapping - convert facts into a process map;
4. analysis - work through the map, challenging each step (what-why?, who-why?, where-why?, when-why?, how-why?).
5. develop/install new methods - eliminate unnecessary work, combine steps, rearrange steps, add new steps where necessary.
6. manage process - maintain process map in library, review routinely, and monitor process for changes;
7. balancing process task – tasks assignment to human resources according to their skills availability.

Nowadays, BPM has become an important tool for industrial practitioners in order to perform an efficient

2351-9789 © 2020 The Authors. Published by Elsevier B.V.

This is an open access article under the CC BY-NC-ND license (<http://creativecommons.org/licenses/by-nc-nd/4.0/>)

Peer-review under responsibility of the scientific committee of the International Conference on Industry 4.0 and Smart Manufacturing.

10.1016/j.promfg.2020.02.017

continuous re-engineering process according to international quality standard (ISO); for this reason, it is incorporated in daily use software under different forms. These include detailed flow-charts, work-flow diagrams and value stream maps. Recently, the new technological paradigms of the smart industry (Industry 4.0) like, IOT, cloud services are enabling new solutions for improving and automating the BPM activities. For instance, [4, 5] propose two different solutions to exploit the augmented intercommunication capabilities of modern Cyber Physical Systems (CPS). Unfortunately, the penetration of CPS in SMEs is still low, but the integration of sensors in the industrial machines can be obtained with retrofit systems and, as it is shown in this paper, this solution can offer several advantages in the SME segment. Among various retrofit technologies, Radio frequency identification (RFID) [6] has been one of the most promising technological innovations of the last decades in the industrial and manufacturing fields. This technology represents one of the main pillars of IOT. It has been widely implemented all over the world and its impact on our daily life is very diverse and massive. Despite the numerous benefits claimed, several barriers, like costs, lack of understanding, technical and privacy issues, have limited its penetration within the Small and Medium Enterprises (SMEs) [7, 8].

In particular, for SMEs, there are still many enabling factors that can contribute to its diffusion and application. Those diverse applications include logistical tracking, monitoring and maintenance of products, product safety and information, payment process [9]. Under this viewpoint, also the automation of BPM represents one of the most valid applications to investigate. To this end, in this contribution, we present a BPM RFID-based toolkit, a simple, yet cheap, retrofit RFID application that can be used in a production environment to analyze and map the processes and measure its performance. Among the various sections of BPM, we will focus on the first four bullet points previously listed: (1) process identification; (2) information gathering; (3) process mapping and (4) analysis.

The paper is organized as follows: Section 2 provides a brief overview about RFID and explains the main components and the functioning of the BPM toolkit. Section 3 presents the case of study of a pharmaceutical company that has been used to test the BPM toolkit. Section 4 resumes the main results of the Business Process Mapping activity. In Section 5, conclusions and future researches are discussed.

## 2. RFID TECHNOLOGY & BPM TOOLKIT

As already said, the RFID has been one of the most potentially disruptive technology of these last years. In order to explain its principle and the working principles of the proposed application, in the next subsections a short description of RFID technology and of the BPM toolkit is provided.

### 2.1. Basics on RFID

Radio frequency identification, known also as RFID, refers to a technology to automatically identify and track tags

attached to objects. A RFID system is generally constituted by a tag (or label) and a reader. RFID tags or labels are embedded with a transmitter and a receiver. The RFID component on the tags have two parts: a microchip that stores and processes information, and an antenna to receive and transmit a signal.

Figure 1 shows the RFID technology working principles. To read the information encoded on a tag, the reader emits a signal to the tag using an antenna. The tag responds with the information written in its memory bank. The interrogator will then transmit the read results to an RFID computer program.

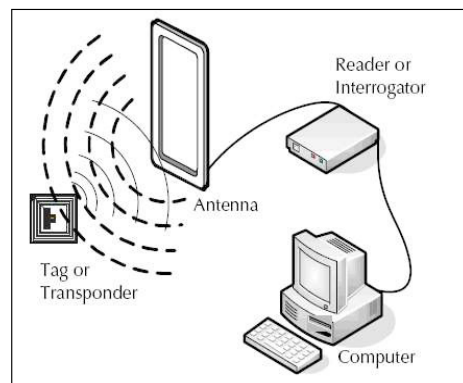

Fig. 1. RFID technology working principles.

RFID is similar to barcoding in that data from a tag or label are captured by a device that stores the data in a database. RFID, however, has several advantages over systems that use barcode asset tracking software. The most notable is that RFID tag data can be read outside the line-of-sight, whereas barcodes must be aligned with an optical scanner.

There are three types of RFID tags: active, semi-passive and passive RFID. Active and semi-passive RFID tags use internal batteries to power their circuits. An active tag also uses its battery to broadcast radio waves to a reader, whereas a semi-passive tag relies on the reader to supply its power for broadcasting. Because these tags contain more hardware than passive RFID tags, they are more expensive. Active and semi-passive tags are reserved for costly items that are read over greater distances as they broadcast high frequencies from 850 to 950 MHz that can be read 100 feet (30.5 meters) or more away. If it is necessary to read the tags from even farther away, additional batteries can boost a tag's range to over 300 feet (100 meters). Passive RFID tags rely entirely on the reader as their power source. These tags are read up to 20 feet (six meters) away, and they have lower production costs, meaning that they can be applied to less expensive merchandise. These tags are manufactured to be disposable, along with the disposable consumer goods on which they are placed.

### 2.2. The BPM RFID Toolkit

The use of RFID technology oriented to the improvement of decision-making processes and production and scheduling

monitoring has been recently proposed in [10] with an ad-hoc application interconnecting many layers of the factory.

Indeed, RFID is a technology that can live and work independently from data-infrastructure of a production environment and can be installed as a retrofit solution to enhance, without necessarily interacting, the functionalities of the existing production environment.

The BPM RFID toolkit hereby proposed works according to this last principle. It is constituted by several devices, named Promag AMP 600 RFID Reader/Write, shown in Figure 2, with the following specifications, as resumed in Table 1 and Table 2. As already said, the BPM RFID-toolkit can be installed, as a retrofit solution without interfering with the IT infrastructure of the manufacturing process.



Fig. 2. Promag AMP 600 RFID Reader/Writer.

Table 1. AMP600 Physical Reader/Writer.

Feature	Value
Operating Frequency	13.56 MHz
Supported Tags	Tag-it® ISO15693 compliant transponders
Interface	RS232, RS485, 19200, n, 8, 1
Power Requirements	12VDC, 300mA (Max. 4W)
RF Modulation	100% FM
RF Protocol	ISO/IEC 15693
Operating Time	< 24ms per one label

Table 2. Antenna ANT-1031 Physical Reader/Writer.

Feature	Value
Dimensions	L345×W240×H20 (mm)
Operating Frequency	13.56 MHz
Reading Distance	Up to 30cm
Antenna connection	SMA-plug (50ohm)
Antenna cable	RG174/2M
Number of tags at the same time	16
Protection class	IP40

The toolkit requires that a worksheet (Work Order) is used to share information along the process under analysis. In order to map the process flow diagram of the main process activities (during the manufacturing or the delivering execution of a order), the worksheet has to be equipped with a RFID tag. In order to realize the association between the worksheet and an

RFID tag, the BPM RFID-toolkit software must execute a write operation of the RFID tag that will be applied in the worksheet (Figure 3). Therefore, together with the printing of the work order, the RFID tag has to be programmed accordingly. In this way, the unique identifier of the work-order will be stored in the RFID tag. In this way, each RFID reader can identify the phases of the worksheet and keep track of the time required for the completion of each phase, from the beginning to the end of the process.

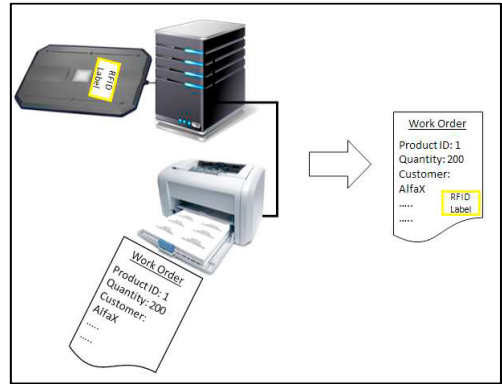

Fig. 3. Association of a RFID tag with a Work Order.

Figure 4 shows an example of production layout of a pharmaceutical company. Although in that production layout, the process can seem straightforward (e.g., from the “Incoming Goods” to the “Warehouse” area), the use of the BPM RFID toolkit can reveal automatically the working flow of a good, without actually knowing the production process characterizing that specific type of good.

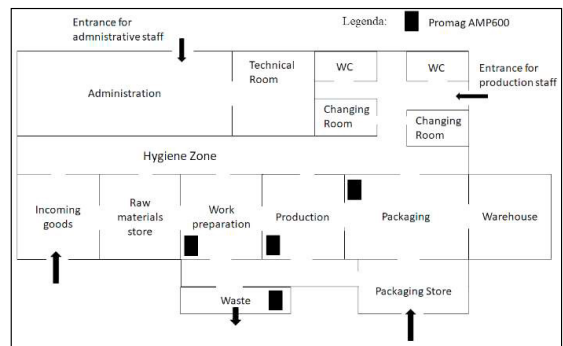

Fig. 4. Layout and working areas example.

For instance, let us imagine two different categories of goods characterized by the production process shown in Table 3. In this example, the difference between Product A and Product B, is that the latter needs two phases in the Work Preparation area that, in the second preparation, will produce a certain amount of waste, before being ready for the final Production and Packaging.

An example of IT architecture for the installation of the BPM RFID-toolkit is shown in Figure 5. Each reader is connected to a PC that needs to be connected to the corporate intranet.

Table 3. Example of production process.

Production Phase	1	2	3	4	5	6
Product A	WP	PR	PA	-	-	-
Product B	WP	PR	WP	WA	PR	PA

All the PCs communicate with a main server that hosts the BPM RFID toolkit software and the main database. The data acquisition software collects all the information events related to a RFID tag. In particular, it registers the identifier of the reader, the timestamps, the identifiers of the RFID tags placed in the reader and the relevant timestamps (when the tag is placed and when it is picked). These data allow to reconstruct the route of the work-order associated to the RFID tag and the time spent in each working area.

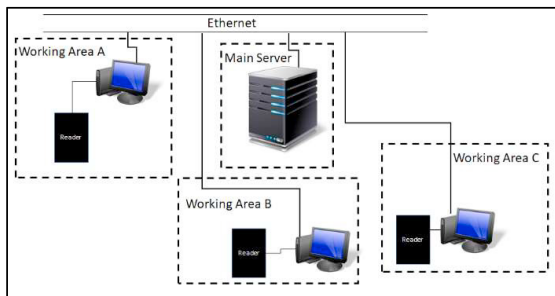

Fig. 5. Example of IT architecture of the toolkit.

As shown in Table 2, the Promag AMP600 can read up to 16 tags at the same time. This represents one of the main constraints of the toolkit, as regard to the automation of the BPM activity. Nevertheless, being a known limit, the process under analysis must not exceed this number of instantaneous tags placed in the same reader of a working area. The setup cost of the BPM toolkit depends only on the number of working areas to map, as they must be equipped with a RFID antenna (a Promag AMP600 – no longer in production – costs about 350\$).

**3. Case Study**

In this section, the case of study of an industrial company is presented. The main information about the production processes and the related technological diagrams are summarized. Afterwards, the results of the experimental campaign will be discussed.

*3.1. The company*

Inalme srl is a company specialized in the production of supplements and cosmetics. Besides selling under its own brand name (process A), the company serves also as third-party production, including private label production (process B). With the private label service, the company responds effectively to the needs of any external company, which can obtain the realization of a product under its own brand, choosing from already defined formulations, studied and controlled with scrupulous accuracy, as well as notified to the Ministry of Health.

In third-party production, Inalme supports the customer along all stages, from the formulation (Research and Development environment) and regulatory environments to the preparation of the finished product. In particular, as regards the complex regulatory aspect, the third-party service includes also regulatory and legislative assistance.

Finally, with its own brand the company delivers a wide range of products to the market entirely conceived within its reality, taking care of all the phases of the production process up to the final distribution.

The production environment is divided into three areas, for the production and packaging (1) of solid supplements; (2) liquid supplements and cosmetics. As regard to the well-known Wortmann classification [11], the production system of the case study, object of this analysis, belongs to the class of Make to Stock (MTS) or Assemble to Order (ATO). As regard to the classification of Brandolese [12] considering the technological axis, the production is driven by process, given the irreversibility of the chemical transformations carried out, for both the processes A and B. As regard to the market axis, production is realized in accordance with a forecast plan for the process A. The process B is managed after third-party orders are procured, almost completely in the active cycle. With reference to the management axis, for the process A the production is pulled by fixed order quantity. For the process B, the production happens according to the third-party order quantity.

*3.2. Technological diagrams of the production cycles*

In this section, the technological diagrams of the production cycles are resumed. The corresponding processes have been studied and mapped “manually”. This knowledge was then compared with the results obtained with the use of the BPM RFID toolkit.

Figure 6 shows the production cycle of the solid supplements.

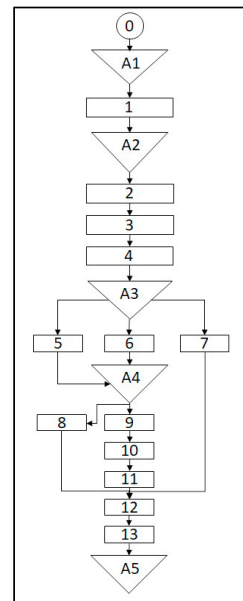

Fig. 6. Production cycle of solid supplements.

The semi-finished products characterizing the solid supplements are tablets, pills and sachets. Sachets steps immediately to the secondary level package (phase 12), whereas pills and tablets must be packaged in the first level packaging phase. In particular, pills are packed in blister packs (phase 8), whereas tablets are bottled, tapped and labelled (phase 9-11).

Figure 7 shows the production process cycle of the liquid supplements.

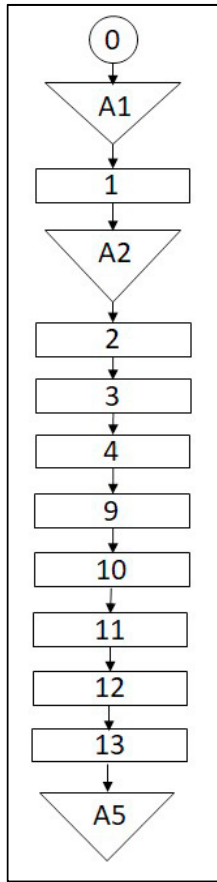

Fig. 7. Production cycle of liquid supplements.

Table 4. Main locations of production process

Phase	Description
A1	Hygiene Zone
A2	Stock Raw Material
A3	Stock Blend
A4	Stock Semi-finished
A5	Stock Finite Product

Finally, Figure 8 shows the production process cycle of the cosmetic supplements that involves three types of formats: tube, jar or bottle. After the weighing of the raw materials (phase 3), two possible mixing processes are possible, the simple (phase 4) or the complex (phase 5). The former characterizes the production of the bottle and jar formats, while the latter features tubes and jars.

Table 5. Phases of solid/liquid supplements production process

Phase	Description
0	Raw Material Handling
1	Quality Control Raw Material
2	Pick up Raw Material
3	Weighing Raw Material
4	Mixing Raw Material
5	Squeezing
6	Encapsulation
7	Bagging (first packaging)
8	Blistering
9	Bottling
10	Tapping
11	Labelling
12	Packaging (2° level)
13	Boxing (3° level packaging)

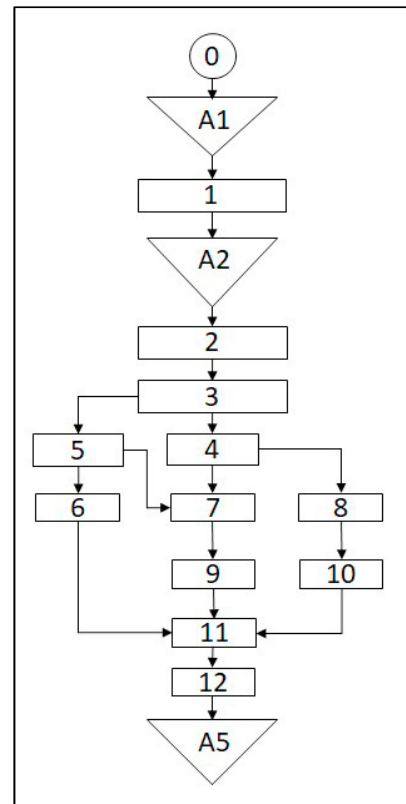

Fig. 8. Production cycle of cosmetic supplements.

#### 4. Experimental Campaign

This section contains the results of the experimental campaign. Two different software applications of the BPM RFID toolkit have been tested to analyse the production processes of the company.

The objective of the first part of the experimental campaign was the validation of the process mapping reconstruction that can be performed, automatically, by the BPM RFID toolkit. Among the three processes available, the cosmetic supplements production cycle was used as case study.

The second application aims to measure the relevant lead times characterizing the main phases of a production cycle. For this second test, the solid supplements production process has been considered. The analysis of the measurements allowed to reconstruct the frequency distribution of the cycle time, identifying for each phase, the probability density functions that better fit the experimental data. This is a valuable result for understanding the most crucial and time-consuming cycles and what possible improvements are needed to reduce bottlenecks.

Table 6. Phases of cosmetic production process

Phase	Description
0	Raw Material Handling
1	Quality Control Raw Material
2	Pick up Raw Material
3	Weighing Raw Material
4	Simple Mixing Raw Material
5	Complex Mixing Raw Material
6	Filling Little Tube
7	Filling Jar
8	Bottling
9	Tapping
10	Labelling
11	Packaging (2° level)
12	Boxing (3° level packaging)

#### 4.1. Automated process mapping reconstruction

Aim of this test is to validate the automated process mapping reconstruction performed by the RFID BPM toolkit, applied to the production cycle of the cosmetic supplements (Figure 8 and Table 6). To this end, each working area (from 3 to 11) of the production line has been equipped with a RFID reader. The choice of placing a RFID reader in the working areas from 3 to 11 is that these working areas characterize the three different types of formats of the cosmetic supplements.

The generic worksheet, equipped with a RFID tag, contains among all the information about the cosmetic supplement to be produced. Therefore, at each phase of the production process, the BPM software is aware of the type of product being processed.

In order to collect a consistent set of data to be processed for automatically design and detect the process mapping characterizing each cosmetic supplement, the application was run for several product cycles. Table 7 contains some of the results acquired for four different cosmetic supplements tracked by the application. It is possible to notice that the product ID 1 refers to a cosmetic supplement of the format little tub. The product ID 2 refers to a cosmetic supplement of the format jar, characterized by a complex mixing, whereas the product ID 3 refers to a cosmetic supplement of the format jar characterized by simple mixing and ID 4 to a product that need to be bottled.

Having acquired these pieces of information, the application was able to reconstruct the process mapping referring to these different types of product and draw the same flow-diagram of Figure 8.

#### 4.2. Measurement of the production cycle phases

Aim of this second test was to measure the relevant lead times characterizing the main phases of a production cycle. With reference to the production cycle of the solid supplements (Figure 6 and Table 5), a RFID reader has been placed in the working area of each phase (from 2 to 12). In this experiment, the sachets format has not been included.

Therefore, the following phases have been object of the time cycle measuring:

- pick up of raw material;
- weighing of raw material;
- mixing of raw material;
- test of semifinished product for pills and tablets. The following features are inspected: dimension, hardness and dosage mixture;
- Phases 5 and 6 that concern the production of the semifinished products.
- test of the 1° level packaging, including the machine setup.
- 1° level packaging.
- test of the 2° level packaging, including the machine setup.
- 2° level packaging.

Figures 9-15 show the cumulative and the probability density function, respectively CDF and PDF, reconstructed by using the measurements acquired with the RFID BPM toolkit. In this paper, only the figures characterizing the production process of the pill format have been included.

Finally, the results of both the pill and tableted format have been used to perform a Pareto analysis in order to identify the most crucial phases of both the production process.

Figure 16 and 17 show the differences between the production time cycles of the tablets and pills. For instance, it is possible to notice that both the processes have a relevant lead time related to the production of the semifinished product. For the pills it is higher because the refining of the powder characterizing the mixture is very critical.

As far as it regards the first level packaging, tablets are more time-consuming because it requires three phases, (e.g. bottling, tapping and labelling) that involve more time, whereas pills need only the blistering.

## 5. Conclusions

In this paper, a Business Process Mapping RFID toolkit has been presented and used to analyze the production cycles of a pharmaceutical enterprise. Moreover, an application for the automated reconstruction of the cycle process of the products produced has been successfully tested.

The system can be useful because:

1. it constitutes a system for the production monitoring in those production environments that still use a worksheet to push the order forward (in many fields of manufacturing);
2. it constitutes a retrofit system for detecting the main parameters of the production, parallel to the real one (for example, it can track temperatures);

3. it can be used as attendance survey system;
4. it constitutes a system for the automatic digitalization and measurement of main information of a process (when the flow diagram and when the measures of business performance are not yet known) (i.e., time of crossing of each phase and cycle time);
5. it is a pilot application useful to trace the flow of matter for the purpose of verifying layout efficiency (elaboration of the spaghetti chart).

Future works should take into account a comparison between the RFID technology hereby proposed and the emerging Bluetooth Low Energy (BLE) technology as well as other consolidated IoT solutions.

Table 7. Data acquired by the BPM toolkit.

Prod. Id	Phase	Entry Timestamp	Out Timestamp
1	3	04/02/2019 11:40:23	04/02/2019 12:12:18
1	5	04/02/2019 12:14:02	04/02/2019 12:51:22
1	6	04/02/2019 14:52:01	04/02/2019 15:44:21
1	11	05/02/2019 11:21:21	05/02/2019 11:54:43
2	3	04/02/2019 15:23:12	04/02/2019 15:58:49
2	5	04/02/2019 16:02:49	04/02/2019 16:42:12
2	7-9	04/02/2019 16:52:12	04/02/2019 17:55:22
2	11	05/02/2019 09:21:41	05/02/2019 10:19:29
3	3	06/02/2019 09:33:38	06/02/2019 10:39:22
3	4	06/02/2019 10:55:02	06/02/2019 11:25:59
3	7-9	06/02/2019 11:55:12	03/02/2019 12:55:31
3	11	06/02/2019 14:33:12	06/02/2019 15:47:02
4	3	06/02/2019 12:13:38	06/02/2019 12:49:38
4	4	06/02/2019 12:54:18	06/02/2019 13:41:52
4	8	06/02/2019 14:14:12	06/02/2019 15:52:42
4	10	06/02/2019 15:55:45	06/02/2019 16:31:21
4	11	07/02/2019 09:34:12	07/02/2019 10:54:37

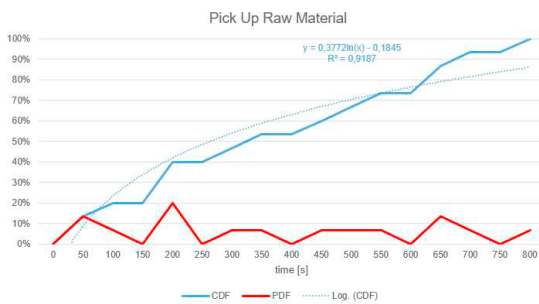

Fig. 9. Probability to complete the pick up in t seconds.

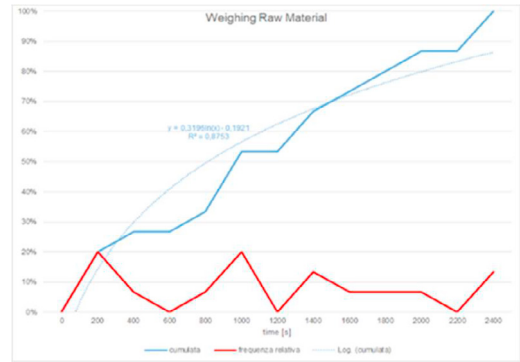

Fig. 10. Probability to complete the weighing in t seconds.

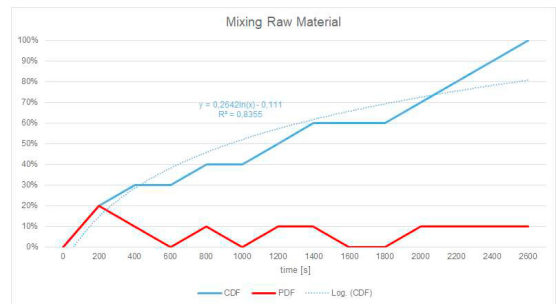

Fig. 11. Probability to complete the mixing in t seconds.

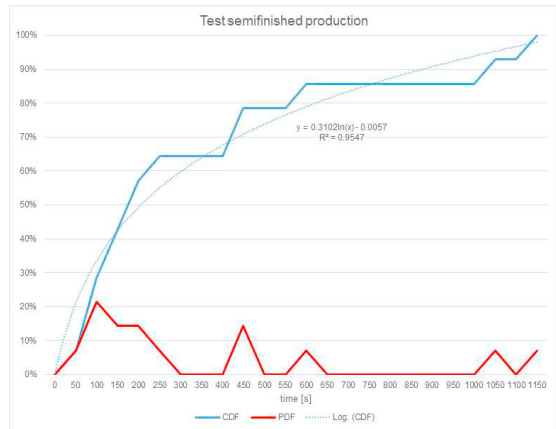

Fig. 12. Probability to complete the test of the semifinished product in t seconds.

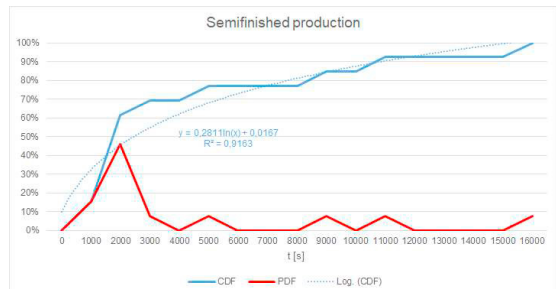

Fig. 13. Probability to complete the semifinished production in t seconds.

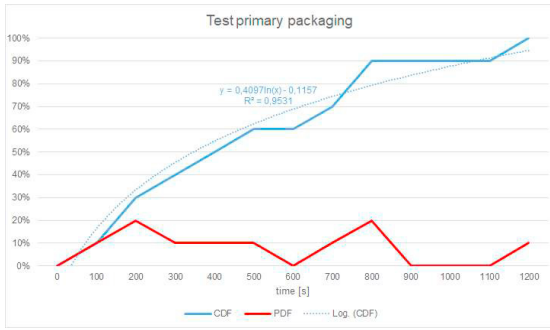

Fig. 14. Probability to complete the test of the primary packaging in t seconds.

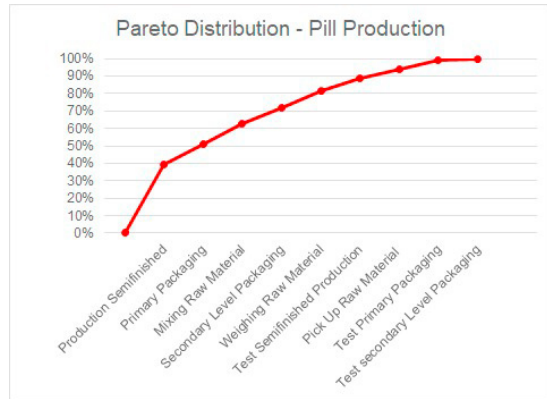

Fig. 17. Pareto distribution of the production phases of the pills.

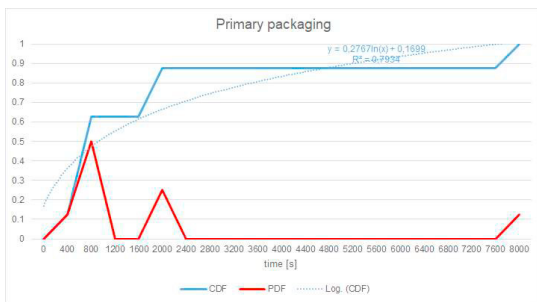

Fig. 15. Probability to complete the primary packaging in t seconds.

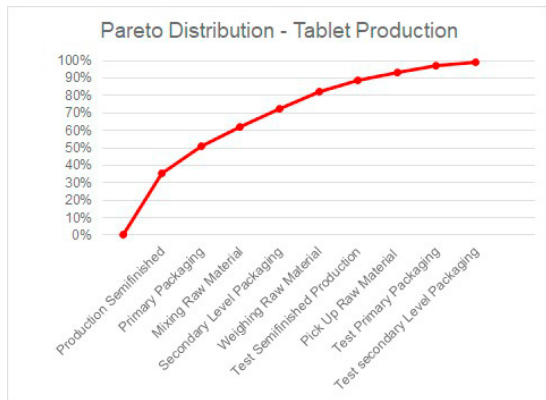

Fig. 16. Pareto distribution of the production phases of the tablets.

### Acknowledgements

Authors want to thank the Inalme Srl for having served as case study.

### References

- [1] Jacka JM, Keller PJ. Business Process Mapping: Workbook.2009. Wiley.
- [2] Koehler J, Tirenni G, Kumaran S. From Business Process Model to Consistent Implementation: A Case for Formal Verification Methods. In IEEE Proceedings. Sixth International Enterprise Distributed Object Computing, 2002, Lausanne Switzerland.
- [3] O'Donohue W, Maragakis A. Quality improvement in behavioral health. 2016, Springer International Publishing.
- [4] Repta D, Moisescu MA, Sacala IS, Stanescu AM, Neagu G. Automated Process Mapping for Cyber Intelligent Enterprise. In 2015 20th International Conference on Control Systems and Computer Science (pp. 679-686). 2015, IEEE.
- [5] Basios A, Loucopoulos P. Six sigma DMAIC enhanced with capability modelling. In 2017 IEEE 19th Conference on Business Informatics (CBI) (Vol. 2, pp. 55-62), 2017. IEEE.
- [6] Wang YM, Wang YS, Yang YF. Understanding the determinants of RFID adoption in the manufacturing industry. Technological Forecasting and Social Change, Volume 77, Issue 5, 2010, pp. 803-815.
- [7] Reyes PM, Li S, Visich JK. Determinants of RFID adoption stage and perceived benefits. European Journal of Operational Research, 254(3), 2016, 801-812.
- [8] Fosso Wamba S, Gunasekaran A, Bhattacharya M, Dubey R. Determinants of RFID adoption intention by SMEs: an empirical investigation. Production Planning & Control, 27(12), 2016, 979-990.
- [9] Jung K, Lee S. A systematic review of RFID applications and diffusion: key areas and public policy issues. Journal of Open Innovation: Technology, Market, and Complexity, 1(1), 9, 2015.
- [10] Guo Z, Ngai E, Yang C, Liang X. An RFID-based intelligent decision support system architecture for production monitoring and scheduling in a distributed manufacturing environment. International journal of production economics, 159, 16-28, 2015.
- [11] Wortmann JC. Chapter: "A classification scheme for master production schedule", in Efficiency of Manufacturing Systems, C. Berg, D. French and B. Wilson (eds) New York, Plenum Press, 1983.
- [12] Brandolese A, Brugger G, Garetti M, Misul M. Analisi dei sistemi di produzione manifatturiera, Finanza, Marketing e Produzione, anno III, 1985.