



# Field bean (*Vicia faba var. minor*) as a protein feed for growing lambs with and without protected lysine and methionine supplementation

Mauro Antongiovanni, Anna Acciaioli, Oreste Franci, Maria Paola Ponzetta, Carolina Pugliese, Arianna Buccioni, Marco Badii

Dipartimento di Scienze Zootecniche. Università di Firenze, Italy.

*Corresponding author:* Prof. Mauro Antongiovanni. Dipartimento di Scienze Zootecniche, Università di Firenze. Via delle Cascine 5, 50144 Firenze, Italy - Tel. +39-055-3288332 - Fax: +39-055-321216 - Email: mauro.antongiovanni@unifi.it

---

*Paper received May 22, 2002; accepted July 17, 2002*

---

## ABSTRACT

Thirty-two Appenninica lambs were submitted to a growth trial from day 60 to day 110 of age (on average) and the composition of gains was estimated by means of the comparative slaughter technique. Sixteen different diets, based on wheat straw as the forage and on field bean (*Vicia faba var. minor*) as the sole protein feed, were tested both by means of ANOVA and of response surface analysis, a multiple regression method designed to study additive and interaction effects. This study thus examined the combined effect of 4 levels of dietary CP (13, 15, 18, 20% DM) and 4 levels of rumen protected lysine and methionine, replacing 4 levels of field bean CP (0, 1, 2, 3 percent units), upon intakes, gains, digestibility and retentions of nutrients within gains. The animals had rather high gains (250 g/d on average) and retention efficiencies both of feed nitrogen and energy. Dietary CP levels higher than 18% and amino acid supplementation appeared of no use in improving the lambs' performance. It is concluded that field bean may represent a valid alternative to soy bean as a protein feed for growing ruminants in the so-called "organic" animal production where transgenic soy is banned.

*Key words:* Field bean, Growing lambs, Protected amino acids.

## RIASSUNTO

IL FAVINO (*VICIA FABA VAR. MINOR*) COME ALIMENTO PROTEICO PER L'ACCRESIMENTO DI AGNELLI, CON O SENZA L'INTEGRAZIONE CON LISINA E METIONINA RUMINO PROTETTE.

*Trentadue agnelli Appenninici sono stati sottoposti ad una prova di accrescimento da 60 a 110 giorni di età (in media) e la composizione degli incrementi ponderali è stata stimata con la tecnica delle macellazioni comparative. Sono state testate 16 differenti diete, tutte basate sulla paglia di frumento come foraggio e con il favino (*Vicia faba var. minor*) come solo alimento proteico, sia per mezzo della ANOVA che della "response surface analysis", un metodo di regressione multipla progettato per lo studio degli effetti additivo e di interazione. Sono stati studiati gli effetti combinati di 4 livelli di proteina grezza (13, 15, 18 e 20% sulla ss) e di 4 livelli di lisina e metionina rumino protette che sostituivano 4 livelli di proteina grezza del favino (0, 1, 2 e 3 unità percentuali) sui consumi, gli incrementi, le digeribilità e le ritenzioni dei nutrienti negli incrementi. Gli animali hanno avuto incrementi piuttosto buoni (250 g/d di media) ed ottimi indici di conversione, sia dell'azoto che dell'energia. I livelli di proteina grezza della dieta superiori al 18% e l'integrazione con amino acidi protetti si sono dimostrati di nessuna utilità nel migliorare le prestazioni produttive degli agnelli. Si conclude affermando che il favino può rappresentare una valida alternativa alla soia come alimento proteico per i ruminanti in accrescimento nella produzione della carne cosiddetta "biologica" in cui la soia transgenica è al bando.*

*Parole chiave:* Favino, Agnelli, Amino acidi protetti.

## Introduction

Field bean (*Vicia faba var. minor*) is not commonly used in animal feeding, yet quite a number of scientific papers have dealt with its use as a protein source in poultry and pig feeding in the last decades (Marquardt *et al.*, 1974; Bhargava and O'Neil, 1979; Riopérez *et al.*, 1987; Boudouma, 1990; Van der Poel *et al.*, 1992; Jansman *et al.*, 1993; Flis *et al.*, 1999) and in lamb feeding (Caballero *et al.*, 1992; Purroy *et al.*, 1992; Surra *et al.*, 1992; Lanza *et al.*, 1999). The common conclusion of all these papers is that the protein fractions of faba bean are qualitatively comparable with those of soy bean, providing the trypsin inhibitor factor which is denatured by autoclaving.

The present work is a further study on field bean as a protein feed for growing ruminants, taking lambs as the reference animals. It is part of a research programme designed to study the quality of alternative protein feeds when associated with wheat straw as the only forage in the diet of growing lambs (Antongiovanni, 1993; Bruni *et al.*, 1996; Franci *et al.*, 1997; Secchiari *et al.*, 1998; Antongiovanni *et al.*, 1998). The use of straw as the only forage was considered necessary in order

to study the protein quality of field bean because wheat straw is practically protein free. In particular, in this study diets with quite high levels of beans have been tested in order to thoroughly study an interesting feed, a possible alternative to soy bean, the major protein source used in animal feeding so far, increasingly so since the BSE incidence banned meat meals. This possible alternative is even more remarkable if we consider that soy bean is not allowed for the so-called "organic" productions, having been genetically modified on a large scale.

Due to the lower content of essential amino acids of field bean as compared with soy bean (Dale, 1998), the experimental scheme included the supplementation with a commercial product (Methio-by®) based on rumen protected lysine and methionine, in order to study the most adequate associations of feed ingredients within the diet.

## Material and methods

### Animals

Forty-eight Appenninica male lambs were weaned at the age of about 40 days and then fed the experimental diets for a preliminary adapta-

Table 1. Equations for the estimation of the lambs' body composition at the start of the trial from the composition of reference animals.

Equation	R <sup>2</sup>	rsd
EBW (g) = 0.809 BW - 155 SA + 59.0 SC + 5,220	0.986	454
CW (g) = 0.376 BW - 176 SA + 42.1 SC + 3,581	0.964	439
BDM (g) = 0.233 BW - 60 SA + 9.03 SC - 1,453	0.967	263
BCP (g) = 0.078 BW - 21.87 SA + 20.68 SC + 2.46 WH + 4.81 CC - 3,047	0.981	109
BGE (kJ) = 6.99 BW - 2,056 SA + 205 CC - 12,000	0.955	8,673

EBW = empty body weight, depleted of gastro-intestinal contents, grams

CW = carcass weight, grams

BDM = body dry matter, grams

BCP = body crude protein, grams

BGE = body gross energy (heat of combustion), kJ

SA = age at the start of the growing trial, days

BW = entire body weight at SA, grams

SC = shin circumference at SA, cm

WH = height at withers at SA, cm

CC = chest circumference at SA, cm

Table 2. Ingredient composition of experimental diets.

Diet n.	Theoretical levels %		Percent composition of ingredients in experimental diets					
	CP	Amino acid substit.	Wheat straw	Field beans	Cereal meal <sup>(1)</sup>	Mineral vitamin suppl. <sup>(2)</sup>	Ca soap added <sup>(3)</sup>	Protected amino acids <sup>(4)</sup>
1	13	0	25	22.9	45.3	5	1.8	0
2	15	0	25	35.3	32.9	5	1.8	0
3	18	0	25	47.6	20.6	5	1.8	0
4	20	0	25	60.0	8.2	5	1.8	0
5	13	1	25	22.4	45.8	5	1.3	0.5
6	15	1	25	34.7	33.5	5	1.2	0.6
7	18	1	25	46.9	21.2	5	1.2	0.7
8	20	1	25	59.2	8.9	5	1.1	0.8
9	13	2	25	21.8	46.2	5	1.0	1.0
10	15	2	25	34.0	33.9	5	0.9	1.2
11	18	2	25	46.2	21.8	5	0.7	1.3
12	20	2	25	58.4	9.5	5	0.6	1.5
13	13	3	25	21.3	46.2	5	1.0	1.5
14	15	3	25	33.4	34.5	5	0.4	1.7
15	18	3	25	45.4	22.3	5	0.3	2.0
16	20	3	25	57.5	10.2	5	0	2.3

<sup>(1)</sup> Maize meal, 50%; barley meal, 50%

<sup>(2)</sup> CaCO<sub>3</sub>, 30%; CaHPO<sub>4</sub>.2H<sub>2</sub>O, 30%; NaCl, 10%; trace elements, 15%, vitamins A, D, E, 15%

<sup>(3)</sup> Liposal ®, Ca salts of hydrogenated olive oil

<sup>(4)</sup> Methio-by ®, lysine, 60% and methionine, 40%, rumen protected with a Liposal layer

tion period of two weeks. Around the age of 60 days ( $56.7 \pm 3$ ) the lambs were weighed and measured for some morphological traits (shin circumference, chest circumference, height at withers, body length, thorax height, rump width). Then, 32 lambs out of 48 were randomly chosen for the growth trial and the other 16 were sacrificed and considered the reference animals of the start of the trial, in accordance with the comparative slaughter technique (Thomson and Cammell, 1980). Their whole bodies were analysed for the chemical composition (moisture, crude protein and ether extract content - A.O.A.C., 1980) and for the heat of combustion

value. The growth trial lasted 50 days. At the end, all the experimental animals were slaughtered and their body composition analysed and compared with that of the same animals at the start, estimated from the composition of the 16 reference lambs, by means of multiple regression equations (Table 1), calculated by the stepwise method (SAS, 1988), using as the independent variables body weight, age and body measures. Independent variables were maintained in the final model when significant at the  $p < 0.1$  level. The equations in Table 1 were used to estimate the body composition at the start of the trial of the 32 animals slaughtered at the end.

Table 3. Chemical composition of experimental diets (%DM).

Diet n.	CP	EE	NDF	ADF	ADL	Ca	P
1	12.1	2.6	32.8	19.3	3.0	1.0	0.4
2	14.5	2.4	32.8	19.8	3.3	1.0	0.4
3	18.1	2.0	32.9	21.7	3.3	0.9	0.5
4	19.1	2.6	34.0	22.7	3.1	1.2	0.5
5	13.2	2.3	33.7	21.0	4.0	0.8	0.4
6	15.7	2.5	35.0	21.3	3.0	0.8	0.4
7	17.2	2.4	35.1	22.7	2.7	1.0	0.5
8	19.8	2.3	35.9	22.4	4.2	1.1	0.5
9	13.1	2.9	32.5	21.3	4.0	1.0	0.4
10	15.5	2.8	33.2	20.7	3.1	1.0	0.4
11	17.5	2.9	33.1	23.1	4.3	1.1	0.5
12	20.4	2.6	37.1	22.0	3.5	1.0	0.5
13	13.2	3.4	32.7	19.9	3.2	1.0	0.5
14	14.2	3.1	32.8	21.2	2.9	1.0	0.6
15	17.1	3.1	34.2	21.6	3.2	0.9	0.6
16	19.4	3.3	35.0	21.1	3.0	0.9	0.5

### Diets

Sixteen different complete diets were tested. The experimental design is simply based upon the administration of the 16 different diets in Table 2 to the lambs (2 animals per diet). The animals were adapted to the assigned diet for a period of 14 days prior to the experimental one. Rations were offered *ad libitum* in the form of pellets so as not to allow the animals to choose between ingredients and to be sure that the lambs actually ate what they were supposed to. To reinforce it, the lambs were kept on peat bedding, in individual pens. The diets were characterised by 4 increasing levels of crude protein (13, 15, 18, 20% CP on the DM basis) and 4 levels of rumen protected amino acids (substituting for 0, 1, 2, 3 percentage units of field bean CP). Lysine and methionine of the commercial product Methio-by® were in the ratio of 60/40. Since the protection coating was a layer of Ca salts of hydrogenated olive oil fatty acids, suitable amounts of Ca soaps of the same nature (Liposal®) were added in order to have the same amount of soaps in all the diets. Wheat straw was

the only forage component of the diets. Table 2 shows the ingredient composition and Table 3 the chemical composition of the experimental diets. As often occurs, the chemical traits didn't result exactly as they were designed, due to pellet manufacturing biases: as an example, CP ranged between 12.1 and 20.4% instead of between 13 and 20%. Individual voluntary feed intakes were recorded daily as the differences between offered amounts andorts. Once a week individual faecal samples were collected from rectal *ampulla* for the estimation of apparent digestibility, using acid insoluble ash (AIA) as the internal marker (Van Keulen and Young, 1977).

### Statistical analyses

All data were submitted to analysis of covariance with the following model:

$$Y_{ijk} = \mu + A_i + B_j + bX_{ijk} + E_{ijk} \quad \text{model [1]}$$

where  $A_i$  is dietary CP%;  $B_j$  is the level of sub-

Table 4. Effect of dietary CP and amino acid substitution level on the performance of lambs.

	Dietary crude protein % (CP)				AA substitution level (SL)				Significance		rsd
	13	15	18	20	0	1	2	3	CP	SL	
Intakes:											
DM (g/d)	1,083	1,141	1,180	1,172	1,141	1,175	1,146	1,115	ns	ns	146
GE (MJ/d)	19.43	20.57	21.24	21.10	20.58	21.21	20.55	19.99	ns	ns	2.62
CP (g/d)	140C	170B	206A	230A	183	196	190	178	**	ns	24.4
Gains (g/d):											
BW	222	243	261	252	247	244	247	240	ns	ns	45.1
EBW	204	234	241	225	234	231	223	216	ns	ns	43.2
CW	125	129	149	130	143	141	129	121	ns	ns	25.4
Efficiencies:											
DM/BW	5.78	5.52	5.31	5.44	5.43	5.68	5.50	5.45	ns	ns	0.50
DM/EBW	6.24	5.72	5.84	6.10	5.71	6.01	6.11	6.08	ns	ns	0.63

A, B, C Different superscripts differ significantly ( $p < 0.01$ )

\*\* Significantly different ( $p < 0.01$ )

stitution with protected amino acids,  $b$  is the regression coefficient on initial body weight ( $X_{ijk}$ ) and  $E_{ijk}$  is the residual error. The interaction between the main effects was not included in the model, due to the small number of replicates per cell. All the parameters have been analysed by the response surface analysis model also (Rousch *et al.*, 1979; Toyomizu *et al.*, 1982, 1993; Franci *et al.*, 1997), to evaluate the influence of the principal effects as continuous variables, by means of a multiple regression procedure (SAS, 1988). The model is:

$$Y = a + b_1X_1 + c_1X_2 + b_2X_1^2 + c_2X_2^2 + dX_1X_2 + eZ$$

model [2]

where  $a$  is the intercept;  $b_1$  and  $b_2$  are the regression coefficients upon dietary CP% ( $X_1$ ), using the actual values of CP content of the diets;  $c_1$  and  $c_2$  are the regression coefficients upon the level of substitution with protected amino acids ( $X_2$ );  $d$  is the regression coefficient on the relative interaction and  $e$  is the regression coefficient on

initial body weight ( $Z$ ). A stepwise procedure was employed and the entrance of the first degree variable into the equations was forced, whereas the other independent variable were kept for  $p < 0.15$  only. To avoid redundancy in the presentation of results, continuous analysis (model 2) was considered for the most important parameters only, or when it added information to results from the discrete analysis (model 1).

## Results and discussion

The growth performances of lambs are reported in Table 4 as the means of the major parameters considered. Intakes were not significantly influenced by either dietary CP or amino acid substitution level, with the obvious exception of CP intakes, highest at the highest CP concentration in the diet. This is not in accordance with the findings of Fluharty *et al.* (1997) and Haddad *et al.* (2001), who acknowledged a positive influence of dietary CP on DM intake. Similarly, gains and feed efficiencies didn't significantly change with increasing dietary CP, even if the absolute values

Figure 1. Trend of empty body weight gain (EBWG in g) in relation to crude protein level (CP in %) and protected amino acids substitution level (SL in %) of diet.

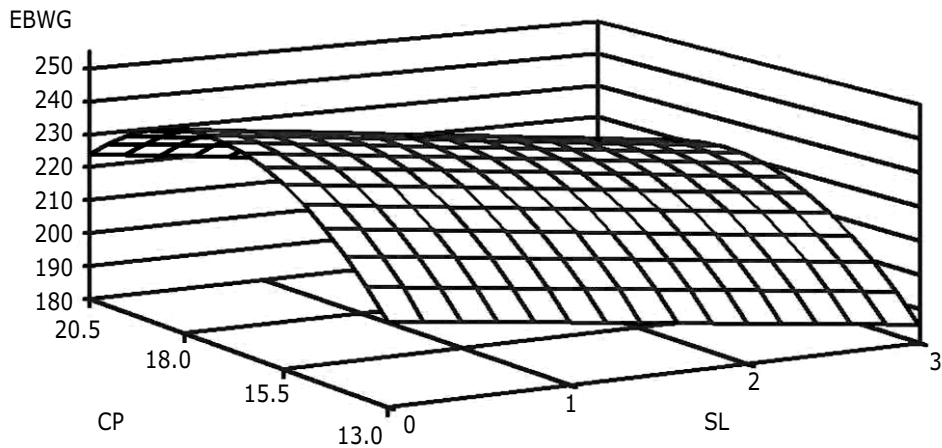

resulted apparently better at the 18% CP level. The shape of the surface shown in Figure 1 (its multiple regression equation is in Table 7), estimated starting from an initial body weight of 18 kg, clearly depicts this result for the empty body weight daily gains, thus confirming the lack of statistical significance ( $P>0.05$ ) of the effect of CP level even at the second degree. The results of previous

trials (Antongiovanni, 1993; Bruni *et al.*, 1996) were not confirmed. When the diet was designed to be correctly balanced in terms of energy and nitrogen, the best performance was achieved with dietary CP levels around 18%. The literature is not very clear on this subject: some authors (Andrews and Ørskov, 1970; Hadjipanayiotou, 1982) consider that dietary CP should range between 15 and 20% for growing

Table 5. Effect of dietary CP and amino acid substitution level on apparent digestibility.

	Dietary CP % (CP)				AA substitution level (SL)				Significance			
	13	15	18	20	0	1	2	3	CP	SL	rsd	
Digestibility, %												
DM	63.5	64.7	63.2	62.0	62.7	63.3	62.9	64.5	ns	ns	3.40	
OM	67.5	68.3	66.7	65.3	66.4	67.0	66.2	68.0	ns	ns	3.34	
CP	66.5C	72.1B	73.4AB	74.7A	69.1B	72.2A	72.6A	73.0A	**	*	2.92	
GE	65.6	67.1	65.1	63.9	65.7	65.3	64.6	66.1	ns	ns	3.49	
Daily digested amounts												
DM, g	693	736	739	729	718	742	716	720	ns	ns	94.2	
OM, g	670	707	712	696	693	716	687	689	ns	ns	89.9	
CP, g	94D	123C	150B	172A	128	142	137	131	**	ns	17.1	
GE, MJ	12.83	13.76	13.73	13.52	13.57	13.85	13.21	13.22	ns	ns	1.78	

A, B, C, D Different superscripts differ significantly ( $p<0.01$ )

\* Significantly different ( $p<0.05$ )

\*\* Significantly different ( $p<0.01$ )

Figure 2. Trend of crude protein digestibility (CPdig in %) in relation to crude protein level (CP in %) and protected amino acids substitution level (SL in %) of diet.

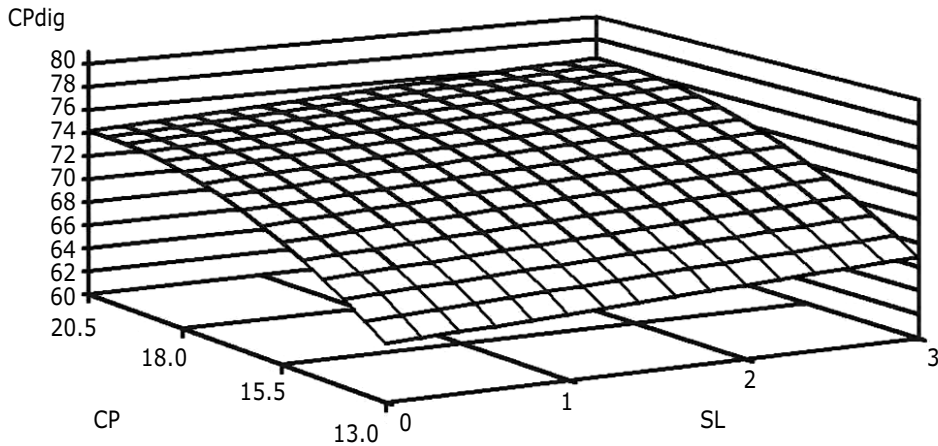

lambs between 15 and 25 kg; other authors (Purroy *et al.*, 1992; Haddad *et al.*, 2001) observe that weight gains improve increasing dietary CP up to 15-16%, but are lower beyond that point. Unfortunately, the results of the present work did not succeed in detecting a significant influence of the CP level on body weight gains.

Both dietary CP and the level of amino acids substitution did not appear to greatly influence the apparent digestibility values, at least when the effects were considered as discontinuous effects with model 1 (Table 5). Only the CP apparent digestibility improved by increasing both dietary CP level and the level of amino acids substitution, the latter from 0 to 1. The parallel trend of increasing CP digestibility with increasing dietary CP level was also observed by other authors (Acciaioli *et al.*, 1994; Sultan and Loerch, 1992; Manso *et al.*, 1998) and attributed to the relatively constant fraction of faecal nitrogen, which has a proportionally lesser weight in high amounts. On the other hand, increasing dietary CP with higher and higher proportions of field bean up to 60%, the amount of tannin increased as well and tannin is known as a stimulating factor of endogenous protein secretion (Marquardt, 1989). With the elaboration of data by means of model 2 (equations shown in Table 7) it becomes evident that

the variation of CP digestibility with increasing dietary CP (Figure 2) had a parabolic shape, whereas the effect of amino acid substitution was not statistically significant, as expected: microbial proteins provide adequate amounts of essential amino acids. Furthermore, the influence of dietary CP upon the digestibility of both DM and energy (Figure 3 depicts the latter) was maximum around 18% CP.

At the end of the trial, the lambs were slaughtered and their whole bodies analysed and compared with the estimated situation at the start of the trial (Table 6). No statistically significant differences could be detected, in spite of the better absolute values obtained for the body composition and retentions with the 18% CP diets, in accordance with the performance results shown in Table 4, but no effect due to the supplementation with protected amino acid could be seen. The retention figures of Table 6 are to be examined with the goal of estimating the nutritive value of the complete diets, expressed as efficiency ratio. As far as the efficiency of energy retention, however expressed, is concerned, no effect due to the considered factors was evident. On the other hand, the efficiency of retained nitrogen worsened with increasing dietary CP, but the amino acid substitution level had no significant effect.

Table 6. Effect of dietary CP and amino acid substitution level on body traits and retention efficiencies of lambs.

	Dietary crude protein % (CP)				AA substitution level (SL)				Significance		rsd
	13	15	18	20	0	1	2	3	CP	SL	
Body composition:											
DM (%)	38.0	38.0	39.3	37.8	38.7	39.4	36.9	38.0	ns	ns	2.04
GE (kJ/g)	10.92	10.73	11.12	10.64	11.12	11.34	10.24	10.71	ns	ns	0.91
CP (%)	16.8	16.7	17.0	16.8	16.3	17.2	16.9	16.9	ns	ns	0.80
Retentions:											
GE (MJ/d)	3,197	3,361	3,754	3,256	3,639	3,741	3,002	3,187	ns	ns	766
CP (g/d)	32.9	34.4	39.5	34.3	33.9	38.0	36.1	33.0	ns	ns	7.37
Efficiencies:											
RE/IE	0.17	0.16	0.17	0.15	0.18	0.17	0.15	0.16	ns	ns	0.02
RE/DE	0.24	0.24	0.27	0.25	0.25	0.28	0.23	0.24	ns	ns	0.04
RN/IN	0.24A	0.20B	0.19B	0.15C	0.19	0.20	0.19	0.19	**	ns	0.33
RN/DN	0.34A	0.28B	0.26B	0.20C	0.26	0.29	0.27	0.27	*	ns	0.05

A, B, C Different superscripts differ significantly ( $p < 0.01$ )

\*\* Significantly different ( $p < 0.01$ )

\* Significantly different ( $p < 0.05$ )

RE/IE = retained energy/ingested energy

RE/DE = retained energy/digested energy

RN/IN = retained nitrogen/ingested nitrogen

RN/DN = retained nitrogen/digested nitrogen

Figure 3. Trend of gross energy digestibility (GE<sub>dig</sub> in %) in relation to crude protein level (CP in %) and protected amino acids substitution level (SL in %) of diet.

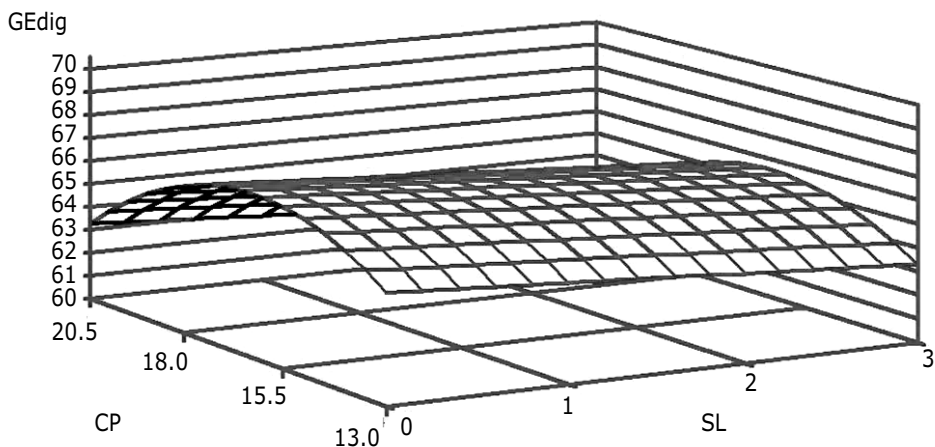



Table 7. Multiple regression equations.

Y	Intercept		Regression coefficients			R <sup>2</sup>
	a	CP	CP <sup>2</sup>	SL	IBW	
Gains (g/d)						
Body Weight	117	4.29*	-	- 2.22	0.003	0.10
Empty Body Weight	- 405	63.6	- 1.82*	- 6.29	0.005*	0.22
Carcass Weight	- 213	31.4	- 0.90*	- 7.67*	0.005**	0.30
Digestibility (%)						
Dry Matter	5.99	7.14**	- 0.22**	- 0.008	- 3.5.10 <sup>-5</sup>	0.25
Gross Energy	12.59	6.67**	- 0.20**	- 0.43	8.38.10 <sup>-6</sup>	0.21
Crude Protein	- 0.46	7.20**	- 0.18**	0.70*	8.45.10 <sup>-5</sup>	0.67
Digested amounts						
Dry Matter (g/d)	- 1,626	211.4**	- 6.05**	- 16.52	0.031**	0.51
Gross Energy (MJ/d)	- 30.20	3.93**	- 0.11**	- 0.44*	0.00058**	0.50
Crude Protein (g/d)	- 372	36.94**	- 0.75*	- 1.93	0.006**	0.85

\*\* Statistically significant ( $p < 0.05$ )

\* Statistically significant ( $p < 0.15$ )

CP = dietary crude protein level (%)

SL = amino acid substitution level (%)

IBW = body weight at the start of the trial (g)

## Conclusions

Field bean (*Vicia faba var. minor*) resulted quite a good protein source for growing lambs and the same statement may be assumed for other ruminants as well. The research for nutritional information about protein feeds uncommonly used is becoming increasingly important because of the banning of meat meals due to the problem of BSE and of genetically modified soy bean in the so-called "biological animal productions". Hence, alternative feeds like field bean must be given relevance.

*The authors wish to express their thanks to SILO (Florence, Italy) for supplying Liposal® and Methio-by®.*

The study was financially supported by the Italian Ministry for University (MURST).

## REFERENCES

- Acciaioli, A., Sargentini, C., Poli, B.M., Martini, A., Ponzetta, M.P., 1994. Confronto tra razze caprine alpine e mediterranee: 2. Digeribilità di diete a diverso contenuto di fibra e proteina. pp 1-11 (sector 2.5) in Proc. Congress "Miglioramento dell'efficienza produttiva degli ovini e dei caprini", Bella (PZ) Italy.
- Andrews, R.P., Ørskov, E.R., 1970. The nutrition of the early weaned lambs (I and II). *J. Agric. Sci. Camb.* 75:11-26.
- Antongiovanni, M., 1993. Wheat straw supplemented with different nitrogen sources for growing lambs. *J. Anim. Sci.* 71 (Suppl.1): 273 (abstr.).
- Antongiovanni, M., Franci, O., Acciaioli, A., Bruni, R., Pugliese, C., Ponzetta M.P., Martini A., 1998. Supplementation of cereal straws with different protein feeds: in vivo studies. *Options Méditerranéennes, Series B.* 17:53-64.
- A.O.A.C., 1990. Official methods of Analysis. 15<sup>th</sup> ed. Kenneth Helrich, Arlington, Virginia 22201, USA.
- Bhargava, K.K., O'Neil, J.B., 1979. Raw and auto-claved faba beans (*Vicia faba* L.) as an alternate

- source of protein for broilers. *Canad. J. Anim. Sci.* 59(3):531-537.
- Boudouma, D., 1990. Valeur nutritive de la fève Sidi Aich (*Vicia faba minor*) et de l'orge Sadiya Est (*Hordeum vulgare*) chez *Gallus Gallus*. *Annales de l'Institut National Agronomique El Harrach.* 14(1-2):21-32.
- Bruni, R., Martini, A., Rondina, D., Acciaioli, A., Antongiovanni, M., 1996. Effect of soy bean and maize gluten feed supplementation in diets based on both urea treated and untreated wheat straw on growing Appenninica lambs. *Zoot. Nutr. Anim.* 22:69-80.
- Caballero, R., Riopérez, J., Fernández, E., Marín, M. T., Fernández, C., 1992. A note on the use of field beans (*Vicia faba*) in lamb finishing diets. *Anim. Prod.* 54:441-444.
- Dale, N., 1998. Ingredient analysis table. *Feedstuffs 1998 Reference Issue.* 70(30):24-31.
- Flis, M., Sobotka, W., Purwin, C., Zdunczyk, Z., 1999. Nutritional value of diets containing field bean (*Vicia Faba L.*) seeds with high or low proanthocyanidin levels for pig. *J. Anim. Feed Sci.* 8(2):171-180.
- Fluharty, F.L., McClure, K.E., 1997. Effects of dietary energy intake and protein concentration on performance and visceral organ mass in lambs. *J. Anim. Sci.* 75:604-610.
- Franci, O., Antongiovanni, M., Acciaioli, A., Bruni, R., Martini, A., 1997. Response surface analyses of the associative effects of lucerne hay, wheat straw and maize gluten feed on growing lambs. *Anim. Feed Sci. Technol.* 67:279-290.
- Haddad, S.G., Nasr, R.E., Muwalla, M.M., 2001. Optimum dietary crude protein level for finishing Awassi lambs. *Small Rum. Res.* 39:41-46.
- Hadjipanayiotou, M., 1982. Protein levels for Chios lamb given high concentrate diets. *Ann. Zoot.* 31(3):269-278.
- Jansman, A.J.M., Huisman, J., van der Poel, A.F.B., 1993. Ileal and faecal digestibility in piglets of field beans (*Vicia faba L.*) varying in tannin content. *Anim. Feed Sci. Technol.* 42:83-96.
- Lanza, M., Pennisi, P., Priolo, A., 1999. Faba bean as an alternative protein source in lamb diets: effects on growth and meat quality. *Zoot. Nutr. Anim.* 25:71-79.
- Manso, T., Mantecon, A.R., Castro, T., Iason, G.R., 1998. Effect of intake level during milk-feeding period and protein content in the post-weaning diet on performance and body composition in growing lambs. *Anim. Sci.* 67:513-521.
- Marquardt, R.R., Campbell, L.D., Sothers, S.C., McKirdy, J.A., 1974. Growth responses of chicks and rats fed diets containing four cultivars of raw or autoclaved faba beans. *Canad. J. Anim. Sci.* 54:177-182.
- Marquardt, R.R., 1989. Dietary effects of tannins, vicine and convicine. In J. Huisman, A.F.B. van der Poel and I.E. Liener (eds.) *Recent advances of research in antinutritional factors in legume seeds.* Wageningen: Pudoc, pp 141-155
- Purroy, A., Echaide, H., Muñoz, F., Arana, A., Mendizabal, J.A., 1992. The effect of protein level and source of legume seeds on the growth and fattening of lambs. *Liv. Prod. Sci.* 34:93-100.
- Riopérez, J., Vinaras, R., Rodriguez, M.L., 1987. Efectos de las semillas de atramuz (*Lupinus albus L. var. Multolupa*) y de los habines (*Vicia faba minor L. var. Prothabon*) en la alimentación post-detección de lechones. *Avances en Alimentación y Mejora Animal.* 27:63-71.
- Rousch, W.B., Petersen, R.G., Arscott, G.H., 1979. An application of response surface methodology to research in poultry nutrition. *Poultry Sci.* 58:1504-1513.
- SAS, 1988. SAS user's guide. Release 6.03. SAS Institute, Inc., Cary, NC, USA.
- Secchiari, P., Ferruzzi, G., Pistoia, A., Bruni, R., Antongiovanni, M., Baricco, G., 1998. Protected amino acids in the diet of growing Appenninica lambs. *Zoot. Nutr. Anim.* 24:77-83.
- Sultan, J.I., Loerch, S.C., 1992. Effects of protein and energy supplementation of wheat straw-based diets on site of nutrient digestion and nitrogen metabolism in lambs. *J. Anim. Sci.* 70:2228-2234.
- Surra, J., Purroy, A., Muñoz, F., Treacher, T., 1992. Lentils and faba beans in lamb diets. *Small Rum. Res.* 7:43-49.
- Thomson, D.J., Cammell, S.B., 1980. The evaluation of energy in forage by the comparative slaughter technique. In Mount, L.E. (ed.), *Proc. VIII Symposium Energy Metabolism.* Butterworths, pp 13-15.
- Toyomizu, M., Akiba, Y., Horiguchi, M., Matsumoto, T., 1982. Multiple regression and response surface analyses of the effect of dietary protein, fat and carbohydrate on the body protein and fat gains in growing chicks. *J. Nutr.* 112:886-896.
- Toyomizu, M., Kimura, S., Tomita, Y., 1993. Response surface analyses of the effect of dietary protein fat and carbohydrate on feeding and growth pattern in mice from weaning to maturity. *Anim. Prod.* 56:251-259.
- Van der Poel, A.F.B., Dellaert, L.M.V., Van Norel, A., Helsper, J.P.F.G., 1992. The digestibility in piglets of faba bean (*Vicia faba L.*) as affected by breeding towards the absence of condensed tannins. *J. Nutr.* 68:793-800.
- Van Keulen, J., Young, B.A., 1977. Evaluation of acid insoluble ash as a natural marker in ruminant digestibility studies. *J. Anim. Sci.* 44:282-287.