

GHGT-12

## Concentrated aqueous piperazine as CO<sub>2</sub> capture solvent: Detailed evaluation of the integration with a power plant

L.V. van der Ham<sup>a,\*</sup>, M.C. Romano<sup>b</sup>, H.M. Kvamsdal<sup>c</sup>,  
D. Bonalumi<sup>b</sup>, P. van Os<sup>a</sup>, E.L.V. Goetheer<sup>a</sup>

<sup>a</sup>TNO – Gas Treatment department, Leeghwaterstraat 46, 2628 CA Delft, the Netherlands

<sup>b</sup>Politecnico di Milano – Department of Energy, Via Lambruschini, 4, 20156 Milano, Italy

<sup>c</sup>SINTEF Materials and Chemistry – Department of CO<sub>2</sub> Capture Process Technology, Post box 4760 Sluppen, N-7465 Trondheim, Norway

---

### Abstract

An integrated energetic evaluation has been performed of a reference coal-fired power plant, a power plant with an advanced MEA-based post-combustion CO<sub>2</sub> capture plant, and a power plant with a capture plant using concentrated piperazine (PZ) and high-pressure flash regeneration. This comparison shows that using a MEA-based capture plant reduces the net electric efficiency from 44.6% to 35.5%, while the PZ-based capture plant reduces it to 37.4%, corresponding to an efficiency penalty of only 7.2%.

© 2014 The Authors. Published by Elsevier Ltd. This is an open access article under the CC BY-NC-ND license (<http://creativecommons.org/licenses/by-nc-nd/3.0/>).

Peer-review under responsibility of the Organizing Committee of GHGT-12

*Keywords:* Concentrated piperazine, Energetic evaluation, Post-combustion capture, Power plant integration

---

### 1. Amine-based CO<sub>2</sub> absorption

Absorption using aqueous mono-ethanolamine (MEA) is currently still the bench-mark process for post-combustion CO<sub>2</sub> capture [1]. In order to development improved capture processes, significant research efforts have been focused on three main development areas: solvent systems [2], capture process configurations [3][4], and integration between the capture process and power plant [5]. A promising alternative solvent is concentrated aqueous piperazine (PZ) [6].

---

\* Corresponding author. Tel.: +31 88 866 28 65.  
E-mail address: [leen.vanderham@tno.nl](mailto:leen.vanderham@tno.nl)

### 1.1. Properties of concentrated piperazine as solvent

One of the main advantages of PZ is its high thermal stability; it can be applied at temperatures up to 150°C, which is considerably higher than the commonly used upper limit of 120°C for MEA. A potential disadvantage of concentrated PZ is that solids can be formed at a combination of a relatively low temperature and CO<sub>2</sub> loading (below 0.6 mol CO<sub>2</sub> per mol PZ at 0°C), and at a high CO<sub>2</sub> loading (above 0.9 mol CO<sub>2</sub> per mol PZ), narrowing down the desired operational range. An increased maximum temperature allows desorption to take place at a higher pressure, resulting in a decrease in the required compressor duty for CO<sub>2</sub> pressurization. On the other hand, thermal energy of higher quality needs to be withdrawn from the power plant.

### 1.2. Configurations for processes using concentrated PZ

Most studies have focused on finding the most efficient capture plant configuration for this solvent [7]-[9] and also on the operation performance in a pilot plant [10]. Especially, the high-pressure desorption step has been assessed extensively. It was found that it can effectively be performed in a two-stage heated flash, using part of the cold-rich solvent stream to recuperate thermal energy at the top of the flash vessels. Recently, a detailed study has been published on the integration between a PZ-based capture process and a power plant [11]. The consequences of the capture process on flexible operation of the power plant are discussed as well.

The current work discusses the main results of this integration study, and focusses on future developments related to the economics of the processes. A comparison is made between two PZ-based capture processes and an MEA-based capture process, both integrated with a coal-fired power plant, and a power plant without CO<sub>2</sub> capture.

## 2. Comparison approach

Four different power plants have been modelled using a combination of in-house GS code [12] for the power plant part of the model and Aspen Plus® for the CO<sub>2</sub> capture part of the model. Both the capture process as well as the power plant are defined according to the guidelines of the European Benchmarking Task Force (EBTF) [13].

The reference power plant without CO<sub>2</sub> capture is based on an ultra-supercritical pulverized coal boiler, using 1657 MW<sub>LHV</sub> of low sulfur South African bituminous Douglas Premium. It has one high-pressure, one intermediate-pressure (IP), and four low-pressure (LP) turbines and includes removal steps for NO<sub>x</sub>, solid particles, and SO<sub>2</sub>. The cross-over pressure between IP and LP is 5.2 bar. Four LP condensate pre-heaters are used and five HP ones. More details of the power plant design and assumptions are described in [11].

Three power plants with CO<sub>2</sub> capture have been modelled: a benchmark configuration using an MEA-based capture process including lean-vapor compression (LVC), a PZ-based process using a two-stage flash configuration with cold rich by-pass, and the same PZ process but using a single-stage flash. The power plant designs are based on the reference power plant described before. However, the cross-over pressure is increased to 6.7 bar for the PZ-based capture processes, while it is decreased to 3.3 bar for the MEA-based capture process, in order to provide steam suitable for heating the flashes/reboiler of the capture plants.

Both the capture plants are designed to remove 90% of the incoming CO<sub>2</sub>. A direct contact cooler is used to pre-treat the flue gas and the inlet temperatures to the absorber are 40 °C. A temperature difference of 5 °C is used in the lean-rich heat exchangers. Produced CO<sub>2</sub> is dried, compressed to 80 bar and pumped to the final pressure of 110 bar.

The PZ-based capture plants use 40 wt% aqueous PZ and are based on the configuration described in [8], comprising absorber inter-cooling, a cold rich by-pass, and flash regeneration. The absorber is equipped with three sections of 5m Mellapak internals; the top and bottom section use type 250X, while the middle section that involves the intercooling uses the more open type 125X. Either one or two flashes are used during regeneration.

The MEA-based capture plant uses 30 wt% aqueous MEA, 12.5 m of Mellapak 2X internals in the absorber, and 10 m of Mellapak 2X internals in the stripper. Pressures of 1.9 bar and 1.1 bar are used in the reboiler and the flash.

Heat released at the condensers of the capture plants and in between the CO<sub>2</sub> compression stages is used to partially preheat the boiler feed water of the power plant. Figure 1 to Figure 3 show the process flow sheets of the capture plants, of the corresponding power plant, and how they are thermally integrated with each other. More details on the design and assumptions use for the capture plants are described in [11].

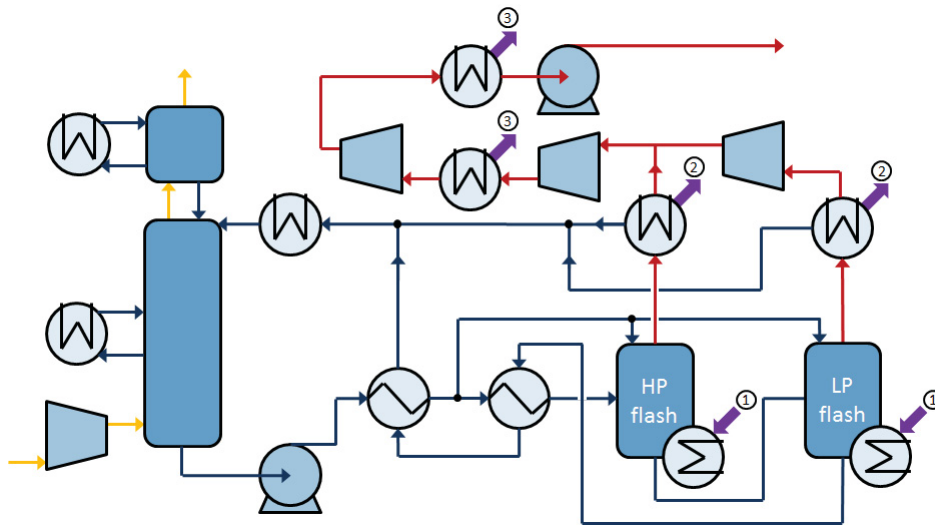

Figure 1: Flow sheet of a CO<sub>2</sub> capture plant with a two-stage flash and cold rich by-pass [8]. Bold purple arrows are used to indicate the locations that are thermally integrated with the power plant shown in Figure 2.

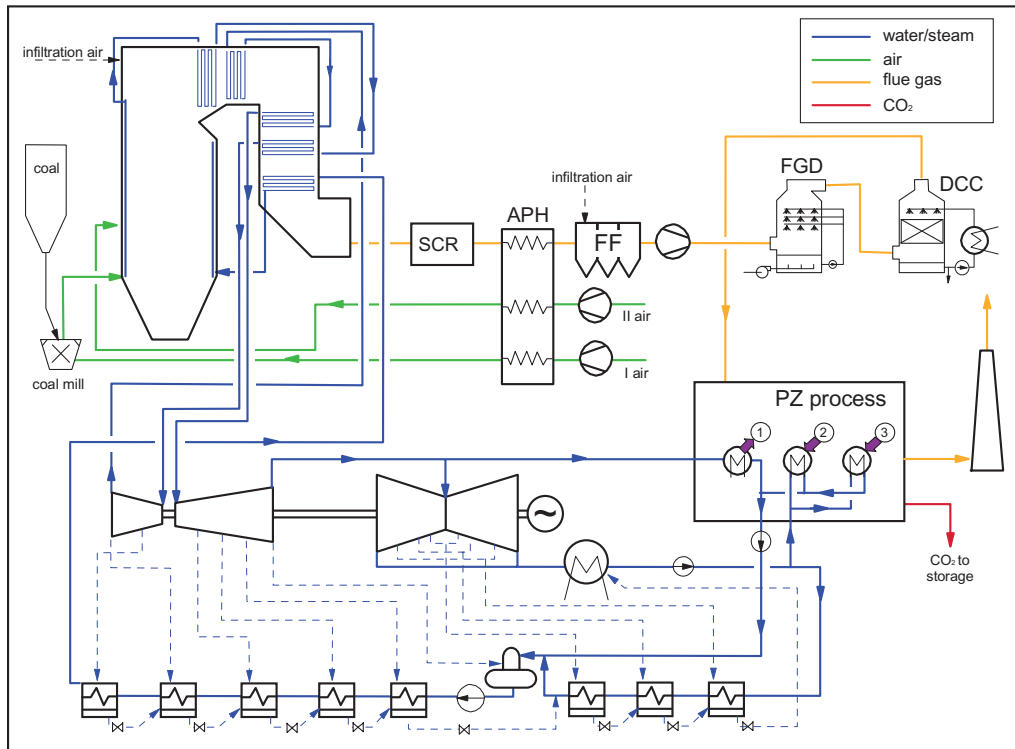

Figure 2: Schematic of the power plant using a PZ-based CO<sub>2</sub> capture process. Bold purple arrows are used to indicate the locations that are thermally integrated with the capture plants shown in Figure 1 and Figure 3.

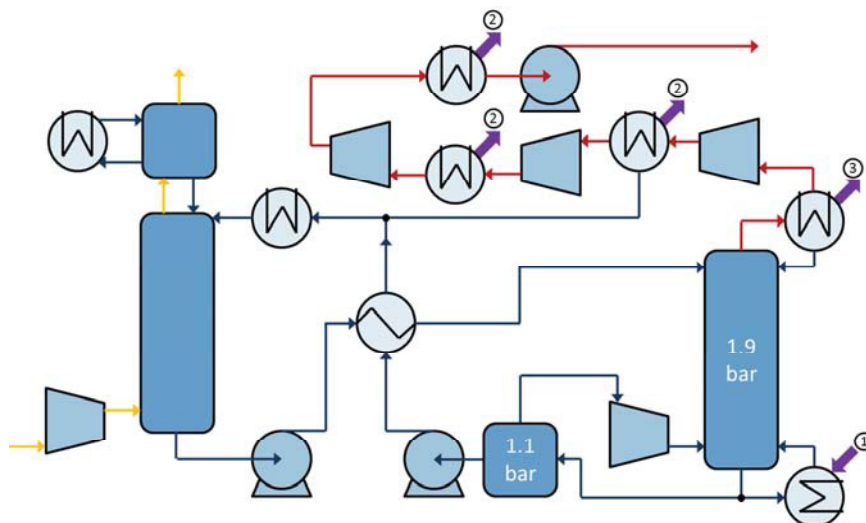

Figure 3: Flow sheet of a CO<sub>2</sub> capture plant with lean vapour recompression. Bold purple arrows are used to indicate the locations that are thermally integrated with the power plant shown in Figure 2.

### 3. Main simulation results

An energetic optimization and evaluation of the PZ-based capture process has been performed, assessing three operating variables: the pressure of the first high-pressure (HP) flash, the pressure of the second low-pressure (LP) flash, and the flash vapor temperature drop. The LP flash pressure is directly coupled to the lean loading of the solvent, while the flash vapor temperature drop is controlled using the fractions of the cold rich solvent that are bypassed to the top of the two flashes. The optimal operating conditions were determined to be a LP pressure of 9.5 bar, corresponding to the imposed lower limit on the lean loading, a HP pressure of 12.5 bar, and a flash vapor temperature drop of 20°C, related to parallel temperature profiles in the second and hottest lean-rich heat exchanger. For the single flash case, a pressure of 9.5 bar was used. Table 1 shows the main energetic performance characteristics of the PZ cases, compared with the reference power plant without CO<sub>2</sub> capture, and the power plant with an advanced MEA-based capture process.

Table 1: Energetic performance characteristics of the three assessed power plants.

Power plant case		Reference	MEA	PZ-2F	PZ-1F
Steam turbine output	MW <sub>e</sub>	796	705	707	707
Electric duty power plant auxiliaries	MW <sub>e</sub>	57	58	56	57
Electric duty capture plant	MW <sub>e</sub>	-	13	9	7
Electric duty CO <sub>2</sub> compression	MW <sub>e</sub>	-	47	23	25
Net electric output	MW <sub>e</sub>	739	588	619	618
Net electric efficiency	% <sub>LHV</sub>	44.6	35.5	37.4	37.3
Net electric efficiency penalty	% <sub>LHV</sub>	-	9.1	7.2	7.3
Desorber heat duty	GJ/ton CO <sub>2</sub>	-	3.3	2.6	2.7

From an energetic point of view, using a PZ-based capture process is more efficient than using an MEA-based one; the penalty points in the net electric efficiency are only 7.2% instead of 9.1%. This difference is mainly caused by the electric duties of the capture plant and CO<sub>2</sub> compression train. Although the thermal duty of the PZ process is significantly lower than the thermal duty of the MEA process, the steam turbine outputs are approximately equal,

which is related to the difference in temperature and pressure at which steam is extracted from the power plant. The single stage flash performs only slightly worse than the two stage flash, suggesting that it might become more favorable in an evaluation that also takes into account the investment costs.

#### 4. Future developments

Recent work suggest that the economics of a PZ-based capture process are not as advantageous compared to an MEA-based capture process [14], as its energetic performance is according to this work. This is amongst others related to increasing investment costs as a result of the relatively high viscosity of the PZ-solvent, and the higher pressures in the regeneration section. Future work will focus on the detailed economics of a power plant using a PZ-based capture process. Examples of relevant variables are the minimum temperature difference used in the lean-rich heat exchanger, the number of flash stages used for desorption, the pump-around flow rate used for the absorber intercooling, the absorber dimensions, and the extent of thermal integration between the power plant and the capture process. After first determining the optimal PZ-based CO<sub>2</sub> capture process, a detailed economic comparison will be made with a power plant without capture and a power plant with MEA-based capture.

#### 5. Conclusion

Based on the energy performance alone, PZ-based capture processes are superior to MEA-based processes: the net electric power plant efficiency is 1.9% higher. Results of a techno-economic analysis will reveal whether PZ-based processes are still better when economics are included. The conclusions of this work contribute to the further development of more-efficient and less cost-intensive processes for CO<sub>2</sub> capture from fossil fuelled power plants.

#### Acknowledgements

Authors van der Ham, van Os, and Goetheer would like to thank the CATO programme (<http://www.co2-cato.org>).

#### References

- [1] Sanchez Fernandez E, Goetheer ELV, Manzolini G, Macchi E, Rezvani S, Vlught TJH. Thermodynamic evaluation of amine based CO<sub>2</sub> capture technologies in power plants based on European Benchmarking Task Force methodology. *Fuel* 2014; 129: 318–29.
- [2] Sanchez Fernandez E, Heffernan K, Van Der Ham LV, Linders MJG, Eggink E, Schrama FNN, Brilman DWF, Goetheer ELV, Vlught TJH. Conceptual design of a novel CO<sub>2</sub> capture process based on precipitating amino acid solvents. *Ind. Eng. Chem. Res.* 2013; 52: 12223–35.
- [3] Cousins A, Wardhaugh LT, Feron PHM. A survey of process flow sheet modifications for energy efficient CO<sub>2</sub> capture from flue gases using chemical absorption. *Int. J. Greenh. Gas Control* 2011; 5: 605–19.
- [4] Sanchez Fernandez E, Bergsma EJ, de Miguel Mercader F, Goetheer ELV, Vlught TJH. Optimisation of lean vapour compression (LVC) as an option for post-combustion CO<sub>2</sub> capture: Net present value maximization. *Int. J. Greenh. Gas Control* 2012; 11S, S114–21.
- [5] De Miguel Mercader F, Magneschi G, Sanchez Fernandez E, Stienstra GJ, Goetheer ELV. Integration between a demo size post-combustion CO<sub>2</sub> capture and full size power plant. An integral approach on energy penalty for different process options. *Int. J. Greenh. Gas Control* 2012; 11S, S102–13.
- [6] Rochelle GT, Chen E, Freeman S, Van Wagener D, Xu Q, Voice A. Aqueous piperazine as the new standard for CO<sub>2</sub> capture technology. *Chem. Eng. Sci.* 2011; 171: 725–33.
- [7] Van Wagener DH, Rochelle GT. Stripper configurations for CO<sub>2</sub> capture by aqueous monoethanolamine and piperazine. *Energy Procedia* 2011; 4: 1323–30.
- [8] Fraillie PT, Madan T, Sherman BJ, Rochelle GT. Energy performance of advanced stripper configurations. *Energy Procedia* 2013; 37: 1696–705.
- [9] Van Wagener DH, Rochelle GT. Cold Rich Bypass to Strippers for CO<sub>2</sub> Capture by Concentrated Piperazine. *Chemical Engineering & Technology* 2014; 37: 149–56.
- [10] Chen E, Madan T, Sachde D, Walters MS, Nielsen P, Rochelle GT. Pilot Plant Results with Piperazine. *Energy Procedia* 2013; 37: 1572–83.
- [11] Kvamsdal HM, Romano MC, van der Ham LV, Bonalumi D, van Os P, Goetheer ELV. Energetic evaluation of a power plant integrated with a piperazine-based CO<sub>2</sub> capture process. *Int. J. Greenh. Gas Control* 2014; 28: 343–55.
- [12] Gecos, 2013. GS software for Gas-Steam cycles. More information available via: [www.gecos.polimi.it/software/gc.php](http://www.gecos.polimi.it/software/gc.php).
- [13] EBTF (European Benchmark Task Force), 2011. European best practice guide for assessment of CO<sub>2</sub> capture technologies. Available via: [www.gecos.polimi.it/research/Large\\_scale\\_energy.php](http://www.gecos.polimi.it/research/Large_scale_energy.php).
- [14] Cottrell A, Cousins A, Huang S, Dave N, Do T, Feron PHM, McHugh S, Sinclair M. Concentrated Piperazine based Post-Combustion-Capture for Australian coal-fired power plants. CSIRO Summary Report, September 2013.