

University of Rhode Island

DigitalCommons@URI

Mechanical Engineering Capstone Design
Projects

Mechanical, Industrial & Systems Engineering

2019

ACRP Design Competition

Gwen Harris

University of Rhode Island

Corey Murphy

University of Rhode Island

Estefany Mejia

University of Rhode Island

Adam Bartlett

University of Rhode Island

Follow this and additional works at: <https://digitalcommons.uri.edu/mechanical-engineering-capstones>

Recommended Citation

Harris, Gwen; Murphy, Corey; Mejia, Estefany; and Bartlett, Adam, "ACRP Design Competition" (2019).
Mechanical Engineering Capstone Design Projects. Paper 73.

<https://digitalcommons.uri.edu/mechanical-engineering-capstones/73>

This Capstone Project is brought to you for free and open access by the Mechanical, Industrial & Systems Engineering at DigitalCommons@URI. It has been accepted for inclusion in Mechanical Engineering Capstone Design Projects by an authorized administrator of DigitalCommons@URI. For more information, please contact digitalcommons-group@uri.edu.

Team 24 ACRP Design Competition



Gwen Harris - Team Leader
Corey Murphy - Design Engineer
Estefany Mejia - Test Engineer
Adam Bartlett - Research and Design Engineer

Sponsor: Dr. Nassersharif
Academic Year 2018-2019
May 6, 2019

Abstract

According to the Federal Aviation Administration, there have been approximately two-hundred thousand civil aircraft collisions with wildlife during the last three decades in the United States alone. Ninety-seven percent of these collisions occurred during takeoff or landing. As of this writing, there is no definitive method used in order to prevent these “bird strikes”, which cause nearly one billion dollars in damages per year in the United States. The team aims to solve this problem. The goal is to integrate an autonomous drone into the daily workings of a local Rhode Island airport. The drone will patrol a designated route along the perimeter of airport grounds and deter birds from foraging or nesting in the area. The drone will be equipped with lights and sounds that are tuned specifically to disrupt bird behavior and communication, thus making the area undesirable. The specific lights and sounds integrated in the drones design are based upon information researched using web-based literary resources. The objective is to not only deter birds from airport grounds, but also to limit the distraction to pilots and airport staff. Implementing ultraviolet lights in the design helps to achieve this goal. Ultraviolet lights give off only trace amounts of light that can be seen by a human eye, but these wavelengths are fully within the bird’s visual spectrum. Therefore, it is possible to minimize the distraction to pilots and staff.

Using the drone provided to the team by Professor Nassersharif, the team performed various tests to determine the most effective method of deterring birds. Equipping the drone with UV lights as well as a speaker that emits predatory bird sounds has proven to be the most efficient method. A flight path was also incorporated into the software to make the drone autonomous.

Table of Contents

1. Introduction.....	1
2. Patent Searches.....	2
3. Competitive Analysis.....	5
4. Design Specifications.....	7
5. Conceptual Design.....	8
a. Corey Murphy’s Design Concepts.....	8
b. Adam Bartlett’s Design Concepts.....	18
c. Gwen Harris’ Design Concepts.....	25
d. Estefany Mejia’s Design Concepts.....	29
e. Evaluation of Design.....	34
6. Design for Safety, Cost, and Reliability.....	39
7. Project Specific Details & Analysis.....	40
8. Detailed Product Design.....	42
9. Engineering Analysis.....	54
10. Build/Manufacture	60
11. Testing.....	64
12. Redesign.....	66
13. Project Planning.....	68
14. Financial Analysis.....	71
15. Operation.....	73
16. Maintenance.....	75
17. Additional Considerations.....	79
a. Economic impact.....	79
b. Societal and Political impact.....	79
c. Ethical considerations.....	79
d. Health, ergonomics, safety considerations.....	80
e. Environmental impact and Sustainability considerations.....	80

18. Further Work.....	81
19. Conclusion.....	83
20. References.....	84

List of Acronyms

ACRP Airport Cooperative Research Program
ESC Electronic Speed Control
FAA Federal Aviation Authority
KV RPM Constant of Motor
QFD Quality Function Deployment
RPM Revolutions Per Minute
UV Ultraviolet
UAV Unmanned Aircraft Vehicle

List of Tables

1. Product Design Specifications.....	7
2. 3DR Iris+ Manufacturer Specifications.....	46
3. Total Mass of Quadcopter (Fully-Equipped).....	54
4. Testing Matrix.....	64
5. Bill of Materials.....	71
6. Maintenance Checklist for Every One Hour of Flight Time.....	76

List of Figures

1. Quadcopter with potential for added lighting and attachments.....	2
2. QFD Chart.....	6
3. Lights mounted on aircraft.....	13
4. Speakers mounted on aircraft.....	13
5. 360 degree light system with integrated speaker.....	14
6. 360 degree light system with integrated speaker and GPS module.....	14
7. Aircraft engine shield.....	15
8. Retractable speaker system.....	15
9. Autonomous ground vehicle with UV lights and speaker system.....	16
10. Autonomous quadcopter with UV lights, speaker system and camera.....	17
11. UVA Strobe with integrated speaker.....	22
12. Automated drone with flashing, under-mounted lights and integrated speaker system.....	23
13. Automated drone with flashing, UVA lights surrounding entire body.....	23
14. UVA lights mounted to wings and each side of fuselage of aircraft.....	24
15. Lights Mounted to the Front of the Aircraft.....	28
16. Drone with Flashing Lights.....	28
17. Light/Laser Design.....	32
18. Light System Design.....	32
19. Spider Design.....	33
20. CAD Image of 3DR Iris+.....	46
21. Front Image of 3DR Iris+.....	47
22. Rear Image of 3DR Iris+.....	47
23. Raspberry Pi 3 B+ Specifications.....	48
24. Raspberry Pi 3 B+.....	48
25. Raspberry Pi 3 B+ GPIO Directory.....	49

26. Raspberry Pi 3 B+ In Case.....	49
27. Commands to run script on startup.....	50
28. Commands to shut off/turn on USB power.....	50
29. Double Jointed 12V/5V Power Converter.....	51
30. Power Converter Connected to 3DR Iris+ and Raspberry Pi 3 B+.....	51
31. Fully Assembled Quadcopter with UV Lighting On.....	52
32. Fully Assembled Quadcopter.....	52
33. Mission Planner Interface.....	53
34. Sik Telemetry Radio.....	53
35. Gimbal mount/Raspberry Pi assembly.....	62
36. Mission Planner Interface.....	67
37. Project Plan.....	68
38. Gantt Chart.....	69
39. Material Costs Pie Chart.....	72

Introduction

The ACRP Design Competition is very open ended and encompasses all manner of topics pertaining to aircraft and airport operations. The guidelines include environmental alterations to runway safety to airport maintenance and more. This granted the team a lot of freedom in deciding which direction to take the project. Initially this was a problem because it was difficult to narrow down a specific problem area. After conducting a great amount of research, the subject of bird strikes stood out the most.

Bird strikes are a common and costly occurrence with over 10,000 instances a year totaling nearly 1 billion dollars in damages. The purpose of our project is to provide a more elegant solution to the problem of bird strikes at commercial airports than methods currently utilized. After weighing the costs and benefits of various strategies, we decided to implement an autonomous drone into everyday airport operations that is modified specifically to increase the probability of bird deterrence from the local area. The design includes auditory and visual stimuli provided via components mounted onto a base drone. As a team, we conducted extensive research that provides justification for the inclusion of the various components of our design. It is important that the design comply with Federal Aviation Association (FAA) regulations, including restrictions on flight height and speed. The components were chosen to create unfavorable conditions for primary bird behaviors including mating, nesting, and foraging. The final design includes ultraviolet lights and predatory bird sounds integrated within the drone's initial structure. A Raspberry Pi 3 B+ regulates and powers the lighting and controls the sound output to a Bluetooth speaker. The speaker and Raspberry Pi are mounted to the underside of the drone via a modified camera mount included with the base drone at the time of purchase.

Patent Searches

US9987971B2: Drone-enhanced vehicle external lights

Date: July 29, 2016

Abstract: “Techniques for drone device control are provided. In one example, the technique includes monitoring, by a drone device operatively coupled to a processor and allocated to a vehicle in operation, one or more conditions associated with the vehicle. The technique also includes, in response to identifying, by the drone device, a defined condition of the one or more conditions: moving, by the drone device, to a position relative to the vehicle and determined based on the defined condition; and performing, by the drone device, an indication operation determined based on the defined condition.” (5)

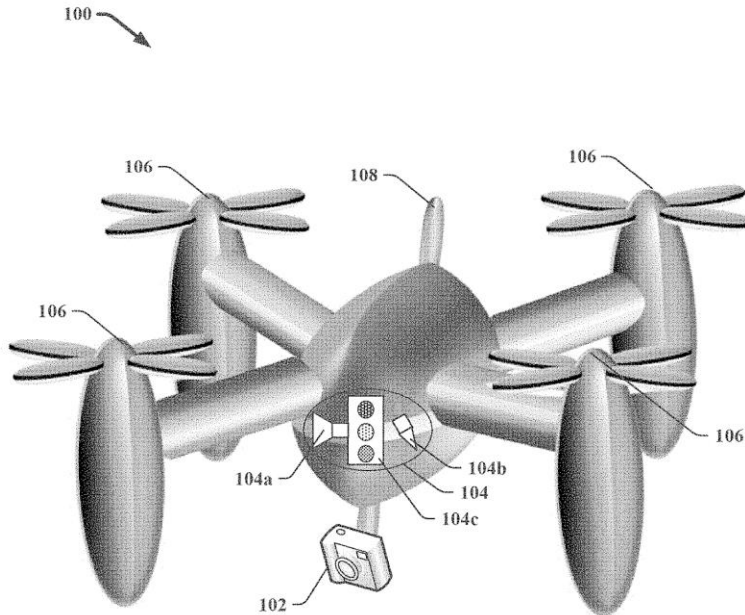

Figure 1: Quadcopter with potential for added lighting and attachments (5)

Pertinence to design: This patent reflects the core of our design. A drone with lighting and the potential for the addition of supplemental attachments. Although we will not be assembling a drone from individual components (we intend to purchase a drone), this drone may be very similar to the one eventually used as our prototype.

US9734684B2: Perimeter monitoring using autonomous drones

Date: January 04, 2016

Abstract: “Aspects include a method, system and computer program product for monitoring a fence about an ad-hoc perimeter. The method includes defining an ad-hoc perimeter to be monitored. A number of autonomous drones are determined for creating a monitoring fence arrangement of the ad-hoc perimeter, each of the autonomous drones including a movement detection mechanism. A position is determined for each of the determined number of autonomous drones. The position is transmitted to each of the autonomous drones. A status of the autonomous drones is monitored. A signal is transmitted in response to at least one of the autonomous drones detecting a breach of the ad-hoc perimeter with the movement detection mechanism.”

Pertinence to design: One of the key features of our design is automation. The drone should be able to fly autonomously on a specified perimeter path around airport grounds. This patent explains one method of doing so.

US4964331A: Airborne birdstrike prevention device

Date: 12/29/1988

Abstract: “A mobile, radio-controlled (RC) airplane flies around an airport in a random pattern, as controlled by an operator with a range greater than needed to scare away birds from runways. The RC airplane includes a receiver to control the launching of a special purpose cracker cartridge having a capsule which burns with a faint smoke trail for a predetermined period of time, after which the projected capsule explodes with a brilliant flash, loud noise, and a small cloud of smoke. By this technique, birds are actually chased out of the path of a runway at an airport. Further, this device can be used to scare birds from agricultural areas, as well as in military training exercises to simulate return fire from attacking aircraft or for use as scare shells during military or paramilitary field training. The cannon firing mechanism which launches the exploding capsule is controlled by a manually operated transmitter from the ground. “ (7)

Pertinence to design: This patent is similar to our design in many respects. Both are aerial drones used to ward off birds from airports using auditory and visual means. It was useful for us to compare our design with other similar designs like this. If we are to patent our design in the future, it is important that it does not infringe upon other patented work such as this. We have to make sure that our design is unique, so that there are no grounds for accusations of plagiarism.

Competitive Analysis

Performing a QFD analysis is a useful tool for comparing the generated design concepts with different competing products. The QFD uses a house of quality to show which products are most successful at meeting customer requirements while also satisfying the quality characteristics. The QFD analysis is shown in Figure 2 on the following page. For this product, the most important customer requirements are reliability, noise reduction, automation, cost efficiency, non-distracting, covering an effective area, and of course deterring birds. The quality characteristics that are most relevant to this project are lights, sound waves, height, lasers, motion sensors, mobility, reducing run time and down time, the product materials, and the life cycle. The two lists were ranked together based on the strength of their relationship. After comparing the relationships, the chosen design concepts were compared to different competitors to determine the best product.

The greatest competition for this product is called PulseLite. PulseLite is a device that is implemented on some airplanes that flashes a bright light from the front of the aircraft. The downside to this product is that since the light is extremely bright, it could be distracting to other pilots or to the surrounding neighborhoods. Using a drone instead would be less distracting and would also allow for a larger area to be effected. The drone is able to patrol all areas outside the airport instead of only the runways. Some other competition includes: shotguns, predatory birds, and chemicals. None of these options are very effective and can also be unsafe.

Design Specifications

3DR Iris+	
Mass with LiPo Battery	1282g
LiPo Battery	3S 5.1 Ah 8C 11.1V
Motors	920kV
Propellers	9.5in x 4.5in
Autopilot	Pixhawk v2.4.5
Equipment	
Mass of Equipment	377.64g
Speaker	Wireless mini bluetooth speaker, runs for 6 hours
Lighting	Black light UV light strip (12V)
Controller	Raspberry Pi 3 B+
Power Converter	Double jointed circuit with 5V BEC
Requirements	
Flight Time Fully Equipped	11 min 37 sec
Durability	Withstand inclement conditions
FAA	Adhere to FAA regulations
Autonomous	Complete route around small airport
Bird Deterrence	Compete with existing methods at lower price
Life Cycle/Maintenance	
Daily Maintenance	Charge LiPo's, plan autonomous flight routes
Monthly Maintenance	Clean and service drone and equipment
Life Cycle	2-4 years

Table 1: Design Specifications

Conceptual Design

Corey Murphy's Design Concepts:

1. A bright, pulsing LED light attached to the base of the aircraft. This is designed to ward off birds with the use of pulsing light. These lights must comply with FAA light emittance regulations. LED lights are not very effective at scaring birds.
2. A bright, pulsing LED light with a speaker attached to base of the aircraft. A combination of pulsing light and a certain sound frequency birds are sensitive to will be used to ward off birds. FAA regulations for sound and light emittance must be met. LED lights are not very effective at scaring birds and sound could be annoying for passengers.
3. Synchronized, bright, pulsing LED lights attached to the wing and the base of the aircraft. Multiple LED's will cover a larger area of the aircraft, theoretically being more effective at warding off birds. FAA regulations for light emittance must be met. LED lights are not very effective at scaring birds.
4. Synchronized, bright, LED lights attached to the wing and the base of aircraft with integrated synchronized sound system. Additional sound emittance at a certain frequency will theoretically be more effective at warding off birds. Must comply with FAA regulations for light and sound emittance. LED lights are not very effective at scaring birds and the sound could be annoying to passengers.
5. A sound system that emits predatorial noises that is attached to the base of the aircraft. This sound system will be consistently running. Predatorial noises will be based on the species of birds that are most prevalent in the area. Must comply with FAA sound regulations. Constant sound emittance would be annoying for the passengers.

6. A sound system that emits noise at a specific frequency that repels birds, attached to the base of the aircraft. This system will be constantly running. The frequency will be determined based on the species of bird that is most prevalent in the area. Must comply with FAA regulations. Constant sound emittance would be annoying for passengers.
7. A sound system that emits predatorial noises based on the planes location due to migratory patterns, attached to the base of the aircraft. The system will operate off of coded information representing the location's bird migration pattern. Migratory patterns are predictable over a year's worth of time, but difficult to predict over the time of a flight.
8. A sound system that emits noise that can only be heard by birds attached to the base of the aircraft. This will be done by utilizing a sound frequency that is inaudible to humans, but audible to birds. This frequency might be too quiet to be audible to birds over the sound of the aircraft's engine.
9. An ultraviolet 360-degree light attached to bottom of the aircraft that repels birds. Certain species of birds are sensitive to certain UV lights, behaving as if the UV lights are predators. A single UV light may not be effective.
10. An ultraviolet 360-degree light attached to bottom of the aircraft with an integrated sound system. The combination of UV light and sound will theoretically be more effective at warding off birds. A single UV light may not be effective and sound would be annoying to passengers.
11. An ultraviolet 360-degree light attached to the bottom of the aircraft with an integrated sound system. The system will operate using GPS data based on aircraft location relative to migratory patterns. Migratory patterns are difficult to predict within the time of a flight.
12. Low drag, high strength aircraft engine guards. The geometry of the guards would have to be designed to be as aerodynamic as possible, with many small inlets to allow the intake to work properly. The material used would ideally be of

high strength that could absorb the impact of a bird(s) at high speed. The most important statistic analyzed in commercial flight today is fuel economy. The amount of drag an engine guard would produce would be too large to economically implement the concept.

13. A reinforced front cone of aircraft to protect the pilots/aircraft from bird strikes. This would be done using high strength material that does not fracture easily. This technology has been implemented on military aircraft, however it is very costly.
14. Reinforced pilot windows on the cockpit of the aircraft. This would be done using high strength polymer inserts in between the panes of glass of the window. This technology has been implemented on military aircraft, however it is very costly.
15. An autonomous ground vehicle projecting sound to scare birds. The vehicle would patrol the grassy areas of the airport where flocks of birds tend to gather. The vehicle would work using an autonomous controller and coded information to emit sound. The biggest issue with this concept is that the vehicle will be limited to ground use only.
16. An autonomous ground vehicle project sound and ultraviolet light to scare birds. The vehicle would patrol the grassy areas of the airport where flocks of birds tend to gather. The vehicle would work using an autonomous controller and coded information to emit sound and UV light. The biggest issue with this concept is that the vehicle will be limited to ground use only.
17. A speaker projecting predatorial noise at the start and the end of the runway. The biggest issue with this concept is that the system will not be mobile and must be installed to one permanent location.
18. A speaker projecting noise that can only be heard by birds at the start and the end of the runway. The biggest issue with this concept is that the system will not be mobile and must be installed to one permanent location. The frequency of the sound may also not be audible to birds over the loud noises occuring around the airport.

19. An autonomous drone emitting sound to scare birds. The drone would circle the perimeter of the airport autonomously using an autonomous flight controller. Sound emittance alone may not be effective enough to ward off large flocks of bird.
20. An autonomous drone emitting sound that can only be heard by birds to scare birds. The drone would circle the perimeter of the airport autonomously using an autonomous flight controller. The frequency of the sound may not be audible to birds over the loud noises occurring around the airport.
21. An autonomous drone emitting sound that can only be heard by birds and utilizing ultraviolet light to ward off birds. The drone would circle the perimeter of the airport autonomously using an autonomous flight controller. The frequency of the sound may not be audible to birds over the loud noises occurring around the airport. Louder predatorial sound might be more effective.
22. An autonomous drone made to look like a predator that flies around perimeter of airport. The drone would circle the perimeter of the airport autonomously using an autonomous flight controller. It would be costly to create a drone that resembles a predatorial bird that also performs well.
23. An autonomous drone made to look like a predator that also projects predatorial noises as it flies around perimeter of airport. Also includes an ultraviolet 360-degree light. The drone would circle the perimeter of the airport autonomously using an autonomous flight controller. It would be costly to create a drone that resembles a predatorial bird that also performs well.
24. A speaker that projects noise only birds can hear prior to every takeoff and landing for a specified amount of time. The sound may not be audible to birds due to the loud noises occurring around the airport and the speakers are not mobile.
25. An electromagnetic shield on the perimeter of runways to ward off birds. Theoretically, this would be extremely effective at keeping birds off of the runway however this is unethical and costly.

26. A 360-degree ultraviolet light attached to an autonomous drone resembling a predator. The drone would circle the perimeter of the airport autonomously using an autonomous flight controller. It would be costly to create a drone that resembles a predatorial bird that also performs well.
27. An autonomous drone resembling a predator emitting predatorial noises and scent. The drone would circle the perimeter of the airport autonomously using an autonomous flight controller. It would be costly to create a drone that resembles a predatorial bird that also performs well and the drone would have to get too close to a flock of birds for scent to be an effective deterrent.
28. An integrated light system along perimeter of the runway to ward off birds at night. This light system could pulse in patterns that deter birds. The lights could be problematic for aircraft pilots that could confuse them when taking off and landing.
29. A low drag, high strength aircraft engine shield that can be automatically removed from the front of the engine after takeoff. The geometry of the guards would have to be designed to be as aerodynamic as possible, with many small inlets to allow the intake to work properly. The material used would ideally be of high strength that could absorb the impact of a bird(s) at high speed. Even if the guard is retractable after takeoff, the guard would still have to be stored externally which would still create extra drag. The most important statistic analyzed in commercial flight today is fuel economy. The amount of drag an engine guard would produce would be too large to economically implement the concept.
30. A speaker built into the ground at the airport that automatically raises and lowers to repel birds. The system(s) could be installed at the most densely populated bird areas around the airport. The biggest issue with this concept is that the system will not be mobile and must be installed to one permanent location. If the airport wants to cover more areas, more systems must be purchased which would be costly.

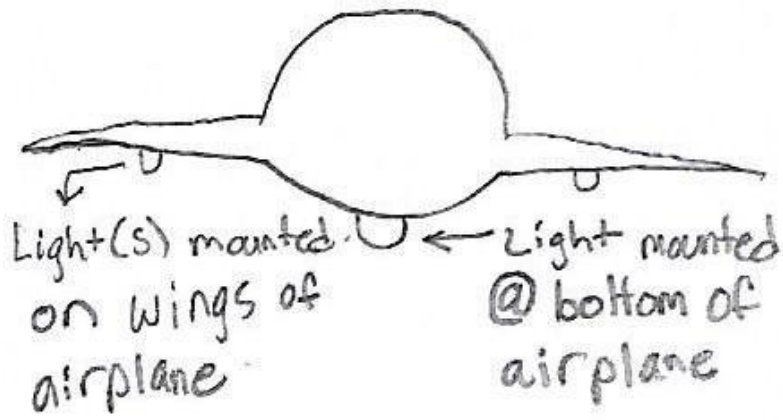

Figure 3: Lights mounted on aircraft

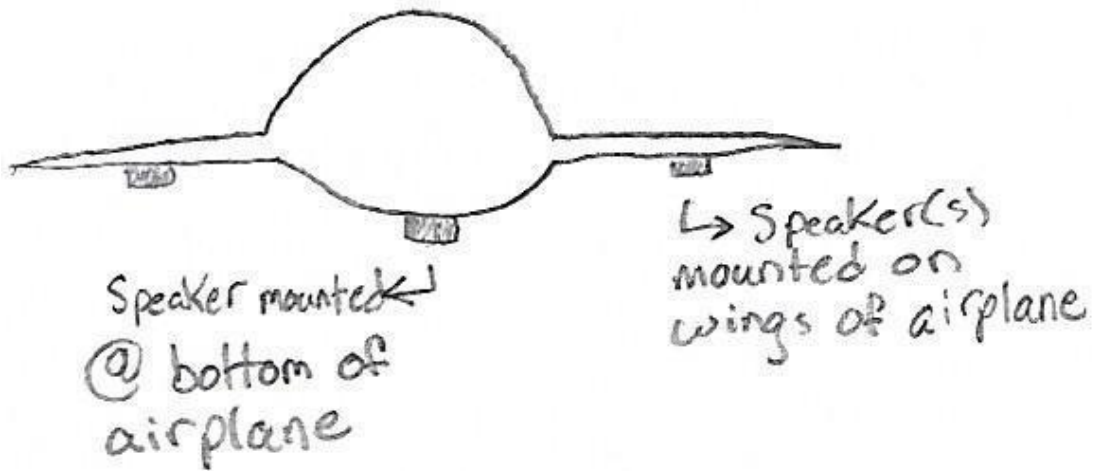

Figure 4: Speakers mounted on aircraft

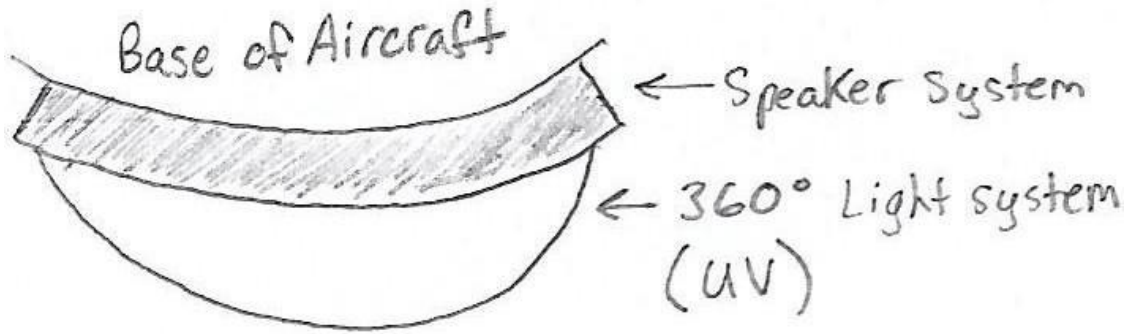

Figure 5: 360 degree light system with integrated speaker

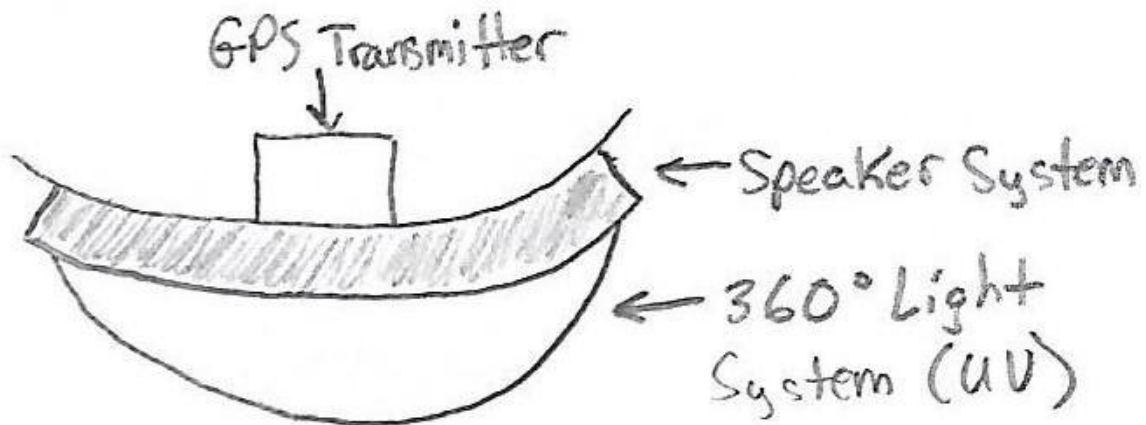

Figure 6: 360 degree light system with integrated speaker and GPS module

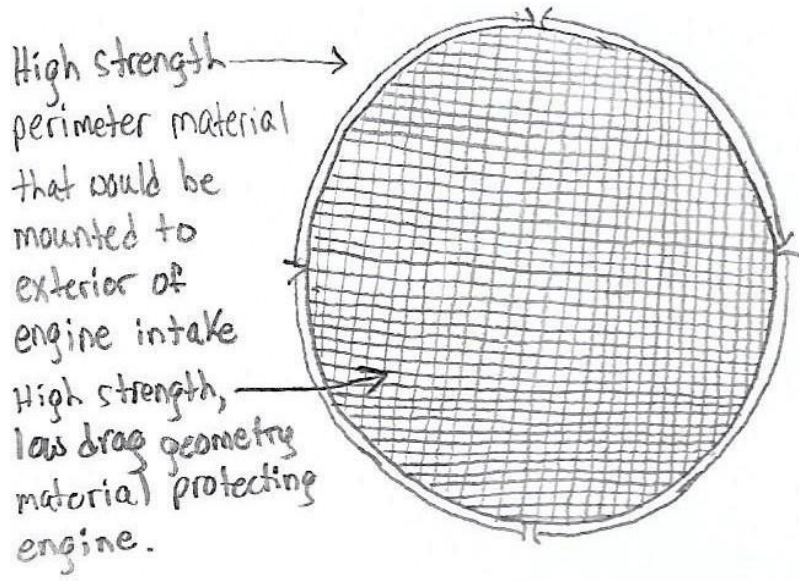

Figure 7: Aircraft engine shield

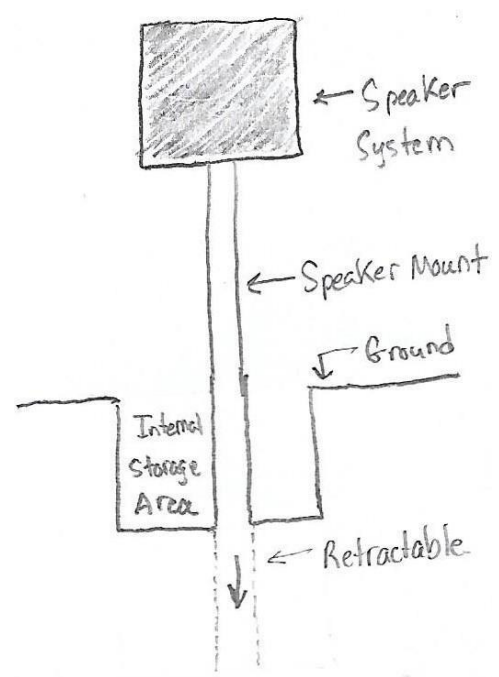
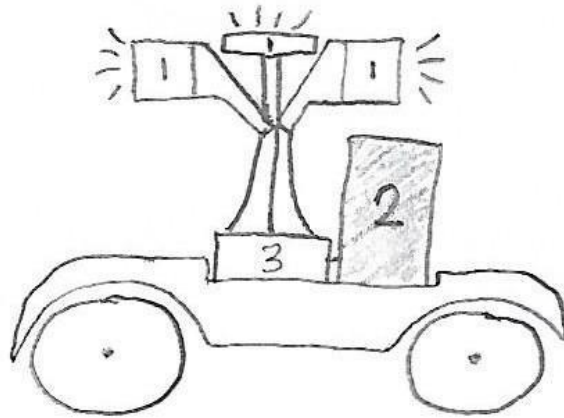
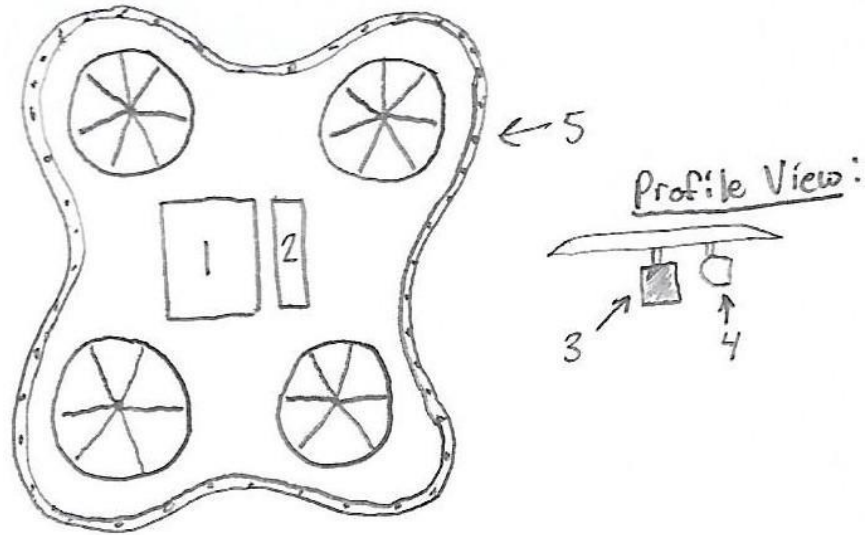

Figure 8: Retractable speaker system



1. UV Light system
2. Predatorial speaker system
3. Autonomous controller in charge of movement, lighting and speaker system

Figure 9: Autonomous ground vehicle with UV lights and speaker system



1. Autonomous Flight Controller
2. Battery
3. Speaker System
4. Front mounted camera
5. Light system mounted around perimeter of quadcopter.

Figure 10: Autonomous quadcopter with UV lights, speaker system and camera

Adam Bartlett's Design Concepts:

1. **Stationary sound and light emittance system:** A speaker and two light sources that would be placed on airport grounds in order to deter birds from nearby fields near runways. The light used would be UVA and would be flashing. The sound used would be "pink noise", or fluctuating sound waves from 2 to 10 kHz at 80 dB.
2. **Stationary light emittance system:** A light source that would be placed on airport grounds in order to deter birds from nearby fields. The light would pulse and emit UVA.
3. **Stationary sound emittance system:** A speaker system that would be placed on airport grounds in order to deter birds from nearby fields. The sound emitted would be variable "pink noise" at 80dB.
4. **Stationary sound and light emittance system with sound barrier:** A speaker and two light sources that would be placed on airport grounds in order to deter birds from nearby fields near runways. The light used would be UVA and would be flashing. The sound used would be "pink noise", or fluctuating sound waves from 2 to 10 kHz at 80 dB. Additionally, a sound barrier would be implemented in order to reduce disruption to airport activities and surrounding residential neighborhoods.
5. **Stationary sound emittance system with sound barrier:** A speaker system that would be placed on airport grounds in order to deter birds from nearby fields. The sound emitted would be variable "pink noise" at 80dB. Additionally, a sound barrier would be implemented in order to reduce disruption to airport activities and surrounding residential neighborhoods.
6. **Stationary sound and light emittance system with reflecting surfaces:** A speaker and two light sources that would be placed on airport grounds in order to deter birds from nearby fields near runways. The light used would be UVA, would be flashing, and would be turned inwardly towards a reflective aluminum

barrier. The sound used would be “pink noise”, or fluctuating sound waves from 2 to 10 kHz at 80 dB.

7. **Stationary light emittance system with reflecting surfaces:** A light source that would be placed on airport grounds in order to deter birds from nearby fields. The light would be turned inwardly toward a reflective aluminum surface. The light would pulse and emit UVA.
8. **Stationary sound and light emittance system with reflecting surfaces and sound barrier:** A speaker and two light sources that would be placed on airport grounds in order to deter birds from nearby fields near runways. The light used would be UVA, would be flashing, and would be turned inwardly towards a reflective aluminum barrier. The sound used would be “pink noise”, or fluctuating sound waves from 2 to 10 kHz at 80 dB. Additionally, a sound barrier would be implemented in order to reduce disruption to airport activities and surrounding residential neighborhoods
9. **UV strobe with speaker:** A strobe light featuring a UVA bulb with an internal speaker. The speaker would emit variable pink noise.
10. **Mounted UV strobe with speaker:** A strobe light featuring a UVA bulb with an internal speaker mounted upon a pole to increase visibility. The speaker would emit variable pink noise.
11. **Telescopically-mounted UV strobe with speaker:** A strobe light featuring a UVA bulb with an internal speaker mounted upon a telescoping pole in order to be able to adjust height. The speaker would emit variable pink noise.
12. **UV strobe with speaker and sound barrier:** A strobe light featuring a UVA bulb with an internal speaker. The speaker would emit variable pink noise. Additionally, a sound barrier would be implemented in order to reduce disruption to airport activities and surrounding residential neighborhoods.
13. **Mounted UV strobe with speaker and sound barrier:** A strobe light featuring a UVA bulb with an internal speaker mounted upon a pole to increase visibility. The speaker would emit variable pink noise. Additionally, a sound barrier would

be implemented in order to reduce disruption to airport activities and surrounding residential neighborhoods.

14. **Telescopically-mounted UV strobe with speaker and sound barrier:** A strobe light featuring a UVA bulb with an internal speaker mounted upon a telescoping pole in order to be able to adjust height. The speaker would emit variable pink noise. Additionally, a sound barrier would be implemented in order to reduce disruption to airport activities and surrounding residential neighborhoods.
15. **Automated aerial drone with bottom-mounted lights and sound emittance:** a quadcopter drone with flashing UVA lights and a speaker system that emits pink noise.
16. **Automated aerial drone with top-mounted lights and sound emittance:** a quadcopter drone with flashing UVA lights and a speaker system that emits pink noise.
17. **Automated aerial drone with front-facing mounted lights and sound emittance:** a quadcopter drone with flashing UVA lights and a speaker system that emits pink noise.
18. **Automated aerial drone with bottom-mounted lights:** a quadcopter drone with flashing UVA lights.
19. **Automated aerial drone with top-and-bottom-mounted lights and sound emittance:** a quadcopter drone with flashing UVA lights and a speaker system that emits pink noise.
20. **Automated aerial drone with front-and-rear-facing lights and sound emittance:** a quadcopter drone with flashing UVA lights and a speaker system that emits pink noise.
21. **Automated drone with flashing lights mounted under propellers and sound emittance system:** a quadcopter drone with flashing UVA lights and a speaker system that emits pink noise.

- 22. Automated drone with flashing lights mounted above propellers and sound emittance system:** a quadcopter drone with flashing UVA lights and a speaker system that emits pink noise.
- 23. Automated drone with flashing lights surrounding entire body:** a quadcopter drone with flashing UVA lights.
- 24. Lights mounted to commercial aircraft:** Four lights would be mounted to the plane. One on each side of the fuselage and one on each wing. The lights are front-facing, would flash, and use UVA bulbs.
- 25. Lights mounted to commercial aircraft:** Four lights would be mounted to the plane. One on each side of the fuselage and one on each wing. The lights would flash and use UVA bulbs. The lights on the wings would be directed at the fuselage to illuminate it.
- 26. Lights mounted to commercial aircraft:** Four lights would be mounted to the plane. One on each side of the fuselage and one on each wing. The lights would flash and use UVA bulbs. The lights on the wings would be directed perpendicularly and outwardly, towards the wings to illuminate them.
- 27. Lights mounted to commercial aircraft:** Six lights would be mounted to the plane. One on each side of the fuselage and two on each wing. The lights would flash and use UVA bulbs. Two of the lights on the wings would be directed perpendicularly and outwardly, towards the wings to illuminate them. The other two would be directed at the fuselage to illuminate it.
- 28. Light mounted on aircraft and stationary strobe device with telescoping pole on ground:** Four lights would be mounted to the plane. One on each side of the fuselage and one on each wing. The lights are front-facing, would flash, and use UVA bulbs. At the airport, there would be a strobe light featuring a UVA bulb with an internal speaker mounted upon a telescoping pole in order to be able to adjust height. The speaker would emit variable pink noise.
- 29. Light mounted on aircraft and stationary sound and light emittance system on ground:** Four lights would be mounted to the plane. One on each side of the

fuselage and one on each wing. The lights are front-facing, would flash, and use UVA bulbs. At the airport, a speaker and two light sources would also be placed on airport grounds in order to deter birds from nearby fields near runways. The light used would be UVA and would be flashing. The sound used would be “pink noise”, or fluctuating sound waves from 2 to 10 kHz at 80 dB.

30. **Lights mounted to commercial aircraft automated perimeter drone at airport:** Four lights would be mounted to the plane. One on each side of the fuselage and one on each wing. The lights are front-facing, would flash, and use UVA bulbs. At the airport, a quadcopter drone with flashing UVA lights and a speaker system that emits pink noise would be used to monitor the perimeter of the grounds.

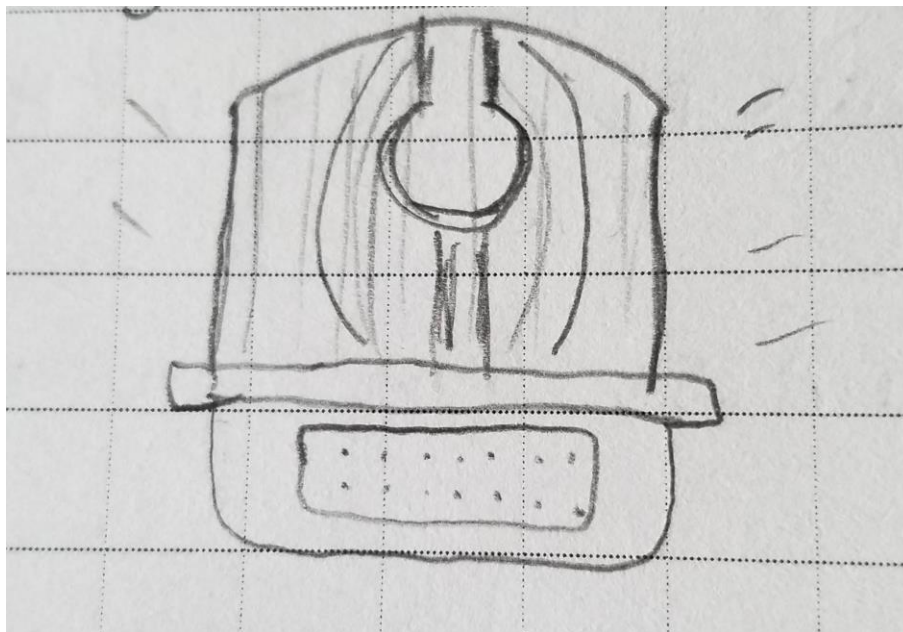

Figure 11: UVA Strobe with integrated speaker

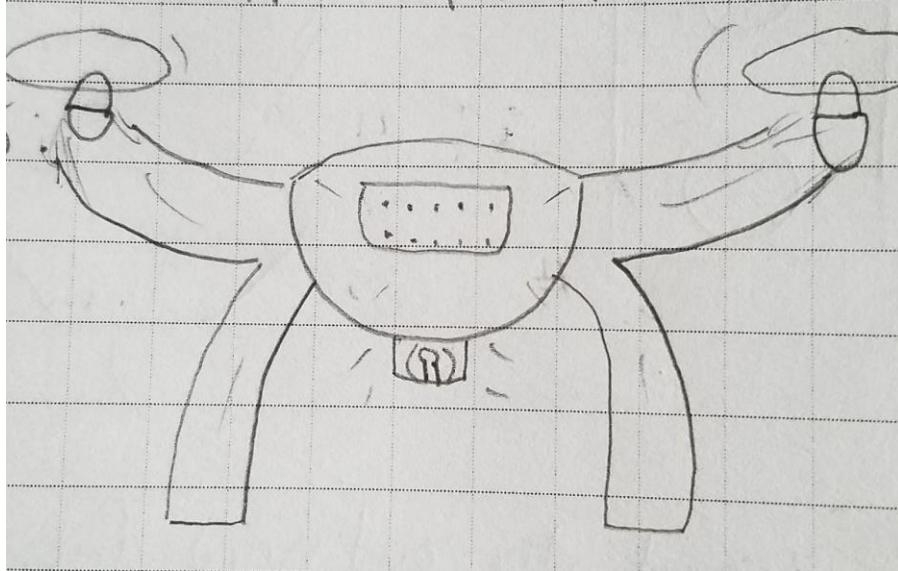

Figure 12: Automated drone with flashing, under-mounted lights and integrated speaker system

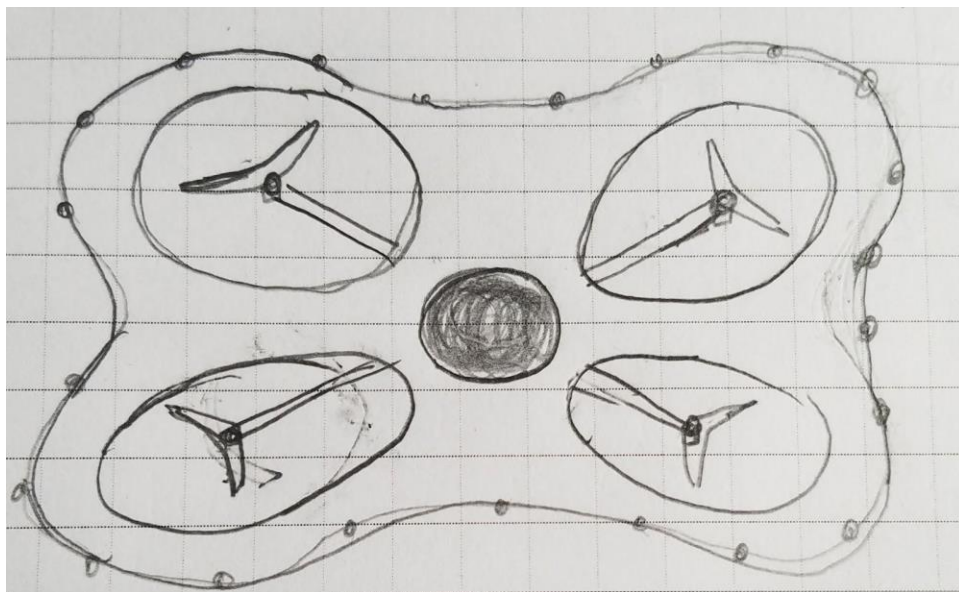

Figure 13: Automated drone with flashing, UVA lights surrounding entire body

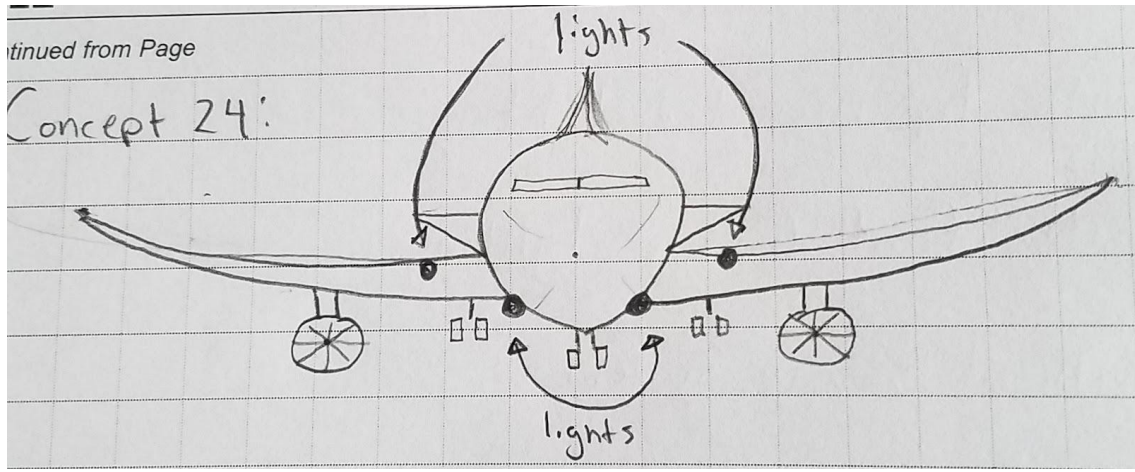

Figure 14: UVA lights mounted to wings and each side of fuselage of aircraft

Gwen Harris' Design Concepts

1. Speaker mounted on the tarmac that emits predatory noises. The speaker would be constantly creating noise to keep birds away.
2. Speaker mounted on the tarmac that emits noise at a frequency that only birds will be able to hear. This is less distracting to surrounding neighborhoods since the noise would not be hearable by humans.
3. Speaker on the ground that creates noise while also flashing bright lights. The speaker would constantly creating noise and the lights cannot be too bright to not be a distraction.
4. Speaker on the ground that creates noise as well as shines ultraviolet lights at the birds. The ultraviolet lights would not be a distraction to the pilots.
5. Ultraviolet lights lining the tarmac to keep birds off of the runways.
6. Flashing lights mounted to the front of the aircraft. The lights would project forward but cannot be too bright.
7. Ultraviolet lights incorporated into the front of the aircraft. The lights would be on throughout the plane's flight.
8. Lights on the front of the plane that flash only during the plane's descent. The lights would project forward to keep birds away during landing.
9. Lights that flash from the wings of the aircraft to keep birds out of the engines. Lights on the wings would create a greater area of effectiveness.
10. Speaker mounted to the front of the aircraft. The speaker would project the sound forward to keep oncoming birds away from the plane.
11. Speaker mounted to the wings of the aircraft. The noise coming from the wings would help keep birds away from the engines.
12. Speaker mounted to the aircraft that only emits noise while the plane is landing. Since most strikes happen when the plane is landing, the noise may only need to be platey during descent.

13. Radar system in the aircraft that detects nearby birds. This would be an expensive solution since it would have to be put in each aircraft.
14. Radar system that illustrates the flight paths of local birds that may be in the plane's path. Although a cheap solution, this method would not be very effective since the pilot would not have much control over what to do if birds were in the vicinity.
15. Vibrations on the tarmac that start when a bird lands on the runway. Sensors would detect when a bird lands and start to vibrate, scaring the birds off.
16. Sensors on the runways that create light when a bird lands. The sensors would detect a bird and shine a bright light to scare them off. This could potentially be distracting to pilots.
17. Sensors on the runways that make noise when a bird lands. Instead of light, the sensors would set off a noise to scare the birds.
18. Sensors on the ground that blast bursts of air at birds when they land.
19. Decoys of the local birds' predators in the fields surrounding the airport. This would not be a very effective solution since the birds would eventually get used to the decoys.
20. A guard that surrounds the front windshield of the airplane to prevent birds from hitting the windshield.
21. Covers that go over the engines to keep birds from flying into the engine. The covers would have to be aerodynamic and not have any effect on the efficiency of the engines.
22. A drone that resembles a predatory bird that flies near the runway. This could be an effective solution however, it would be rather costly to create a drone that looks like a specific bird.
23. A drone that flashes lights. The lights would not be able to be too bright since they could potentially distract the pilots.
24. A drone that shines ultraviolet lights. This would be a more effective solution since the lights would not be distracting and could be seen by birds.

25. A drone that emits predatory noises. The noise emitted has to be loud enough for birds to hear over the sounds of the airport but not too loud as to be a distraction.
26. A drone that both shines ultraviolet light and also emits noise. This would be an effective solution since both UV light and noise could work together to keep birds away. Since the drone is in flight, it would keep birds that have not landed away.
27. A vehicle that drives around the airport grounds to scare off birds. The vehicle would be limited to only eliminating birds that have landed.
28. A retractable post that has a light at the top. The post would be able to come out when a plane is ready to take off or land. The light would have to be not too bright since it is near the runway.
29. A retractable post that flashes ultraviolet light 360-degrees. The ultraviolet light would not be distracting to pilots.
30. A retractable post that has a speaker attached to the top. The speaker would have to be loud enough so that the birds can hear the sounds.

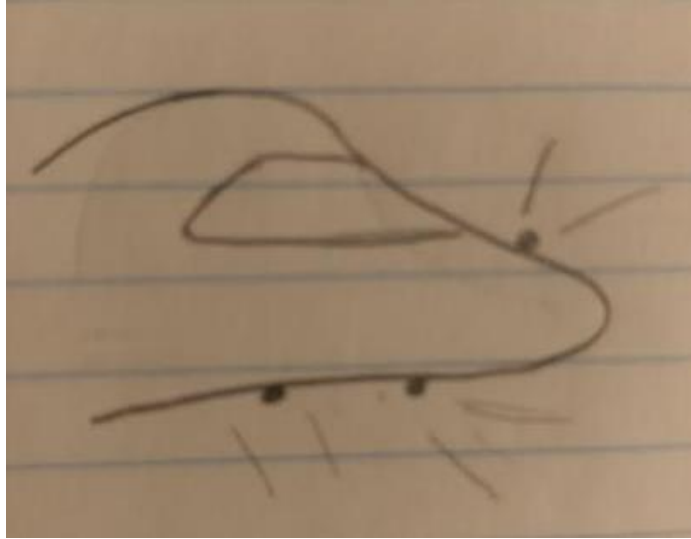

Figure 15: Lights Mounted to the Front of the Aircraft

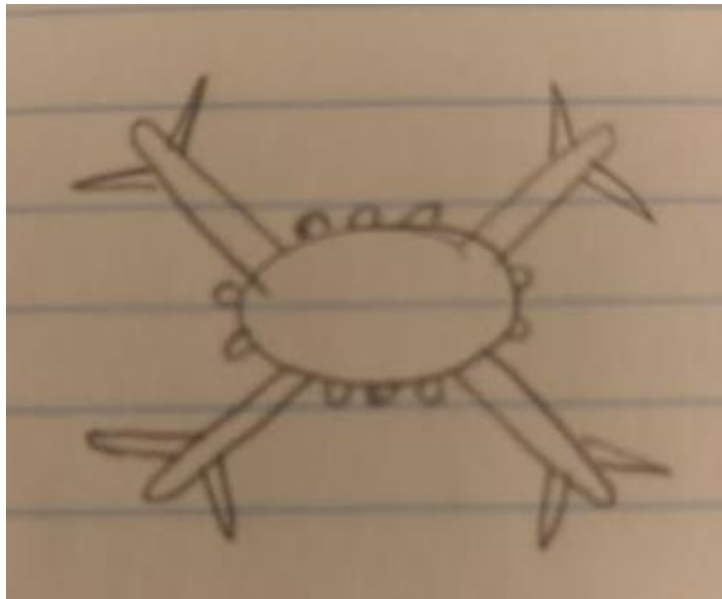

Figure 16: Drone with Flashing Lights

Estefany Mejia's Design Concepts:

1. Light/laser device: This device would be stationary and would surround a specific area of an airport. It would give off certain light wavelength that would only be visible to birds. More than one of this device would be used to be able cover an area of more than 100 square feet.
2. Sound device: This device would look very much like the first design and would have the same basic setup. The only difference would be that the speaker would give out a frequency that the birds can hear.
3. Speaker system: Another sound emittance system that would work like the second design. There would be two speakers mounted on top of each other and they would be placed at each corner of the specified area.
4. Vertical-axis speaker system: This device would have one vertical pole and a perpendicular pole. At the ends of the perpendicular pole, there would be a speaker. The speaker would emit a frequency and the vertical pole would rotate on its axis.
5. Vertical-axis speaker system with light: This device would have the same setup as the fourth design, however, it will have a light attached at the end of the vertical pole. It would emit a light wavelength that only birds can see.
6. Stadium lights: With this design, there would only be one row of five lights with the specified wavelength. These lights would be stationary and would be about 5 feet above the ground.
7. Stadium speakers: Would essentially have the same construction as the sixth design concept, only the lights would be replaced with speakers with the specified frequency.
8. Stadium speakers with lights: This design would have the same stadium speakers as design concept seven. There would be three lights placed right above the compartment where the speakers are in.

9. Bird scarer: This system would be a compacted system that would sprout from the inside out with web like tentacles when activated. When the device is activated, a speaker would emit the specified frequency.
10. Bird scarer/light: This system would be have the same concept as the ninth design. When the device is activated, there would be a light emitted from the middle of the system.
11. Bird scarer combo: Same concept as design nine and ten. The speaker would be in the middle. The lights would be placed right at the ends of each tentacle. This device would be able to rotate.
12. Disco ball: This device is exactly as it sounds. The lights would emit the specified light wavelength and it would be able to rotate. It could be placed on the ground or on poles.
13. Reflective material on aircraft: This material would be placed on the front or on the bottom of the aircraft in order to deter birds from the aircraft itself.
14. Light/laser device: Similar to design one. The difference would be the length of the tube the light would be emitted from. This device would be able to move along the vertical axis.
15. Speaker device: Similar to design one. The difference would be the length of the tube the speakers frequency would be emitted from. This device would be able to move along the vertical axis as well.
16. Unmanned aircraft vehicle with light and speaker: This UAV would be fully equipped with lights and speakers. It would follow a specific route that would be programmed depending on the area.
17. Unmanned aircraft vehicle with speaker: This UAV would be fully equipped with speakers. It would follow a specific route that would be programmed depending on the area.
18. Unmanned aircraft vehicle with light: This UAV would be fully equipped with speakers. It would follow a specific route that would be programmed depending on the area.

19. Unmanned aircraft vehicle/disco ball: The UAV would be combined with design 12. It would follow a specific route that would be programmed depending on the area.
20. Cone speakers: These speakers would have a cone shape to them and would be placed on the fence that surrounds the airport, specifically at each pole on the fence.
21. Cone lights: These lights would have a cone shape to them and would be placed on the fence that surrounds the airport, specifically at each pole on the fence.
22. A simple net design: This design would be a simple net placed over the specified area. This would be inconvenient for birds due to the fact that it would be harder to access the grass and it could be possible that they get tangled in the net as well.
23. Mobile robot with lights: This robot would be equipped with lights. It would move along the ground on a programmed route.
24. Mobile robot with speaker: This robot would be equipped with speaker that can rotate on its axis. It would move along the ground on a programmed route.
25. Light device: Another configuration of the first design. It would be placed on the fence surrounding the airport.
26. Umbrella cover: This device would look like a big umbrella. The material would be see through and embedded with small LED lights. It would also have small holes that would let rain water seep through.
27. Light system: This device would be shaped like a snow plow. It would have 6 lights with 3 lights in each row. It would be placed on poles, 4 feet above the ground.
28. Speaker system: This system would have a single speaker surrounding an area. The size of the area would determine how many speakers would be placed there.
29. UAV disco: This UAV would be shaped like a disco ball and would emit LED wavelengths.

30. Spider robot: This robot would be combed with design eleven and would be programmed to follow a specific route.

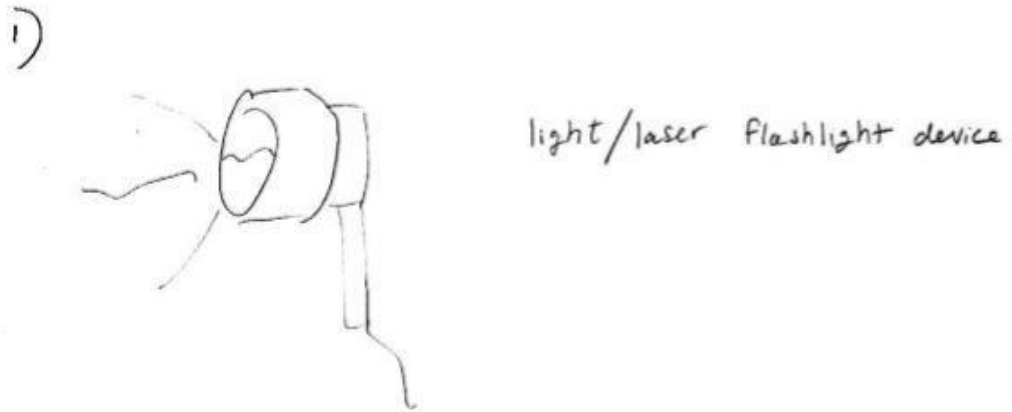

Figure 17: Light/Laser Design

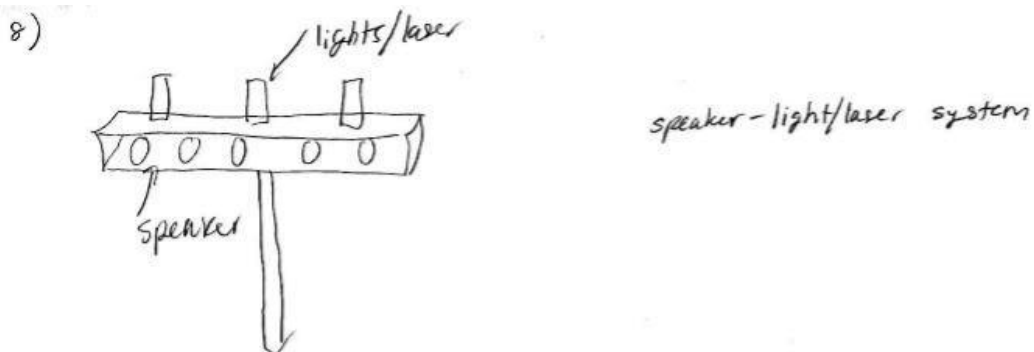
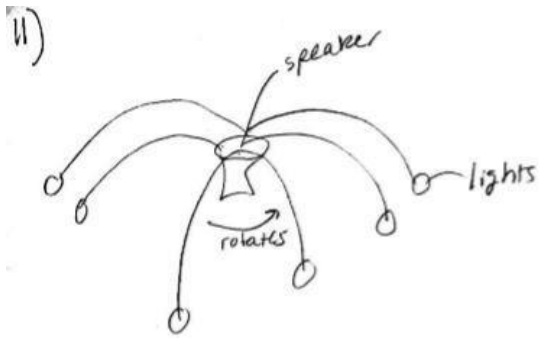

Figure 18: Light System Design



Bird net/web. w/ light and speaker

Figure 19: Spider Design

Evaluation of Design

The 120 concepts generated above were evaluated and classified into three main categories: Apparatus Mounted to Aircraft, Stationary Airport Installation and Mobile Autonomous Airport Vehicle. The positives and negatives of each classification are evaluated and analyzed below.

Apparatus Mounted to Aircraft

The concepts that were specifically designed to be mounted to the actual aircraft itself focused on eliminating the effects of bird strikes that occur while the aircraft is in flight. A bird strike that occurs while a plane is in flight, specifically at high altitudes, pose the most dangerous situations for an aircraft. These bird strikes however, rarely take place while the aircraft, specifically a commercial airliner, is at cruising altitude (approximately 35,000 feet). This accounts for only approximately 3% of bird strikes each year (17). A vast majority of bird strikes occur when the aircraft is landing (60%), with the remaining percentage (37%) taking place while the aircraft is taking off or climbing (17). This significantly diminishes the need for an apparatus to be directly mounted to the aircraft because most bird strikes occur in close proximity to the airport.

The majority of the concepts generated that fall under this category utilize a UV light source and sound emittance to deter birds that may be in the vicinity of the aircraft. From the statistics above, a commercial airliner traveling at a normal cruising altitude is unlikely to come into contact with any bird species. This essentially deems the apparatus that is mounted to the plane unnecessary for a majority of the flight. A mounted apparatus could be useful during times when the aircraft is at lower altitudes. A UV light and speaker system mounted to the aircraft could be activated during takeoff/climb and descent/landing and then switched off when at cruising altitude.

Problems would most likely occur due to the effective radius of the system relative to the aircraft. The speaker would have to project a sound that is incredibly loud that is not only audible to a flock of birds, but also gives the birds enough time to react and fly away from the aircraft. Sound emittance of this magnitude would not only be annoying for passengers and airport patrons, but would also be an annoyance to the residents living near the airport. These problems would require the speaker system to be removed from the design, leaving only the mounted UV lights. A product similar to this called the PulseLite already exists, which diminishes the purpose of pursuing this concept.

Due to the negatives that statistically a vast majority of bird strikes occur close to the airport itself, the issues with intense sound emittance and competition already existing in this classification, it was determined that an apparatus mounted to the aircraft was not a viable option to continue pursuing.

Stationary Airport Installation

A vast majority of bird strikes occur at and around the perimeter of the airport itself. Because of this statistic, it can be assumed that the most effective method of eliminating bird strikes would be focusing on a design that is installed at the airport itself. There were many designs that fell under this classification, with many being unrealistic due to high cost technology. The designs that were deemed more realistic mostly utilized UV light and sound emittance to deter flock of birds that congregate around the airport.

It is crucial that the radius surrounding the runway an aircraft is taking off from is completely clear of birds that could potentially interfere with an aircraft taking off or landing. This favors the designs that would be installed closer to the proximity of the runway itself. An apparatus that includes a UV light system and/or a sound emittance system that could be installed around the runway was carefully analyzed due to its

positive cost efficient to effectiveness ratio. In order to minimize the distraction of a light/sound system and the climate effects that could degrade the apparatus overtime, the designs that included a mounting system that could retract into the ground when not in use were chosen to pursue.

Many airports have already implemented a Sonic Cannon which is essentially an intense sound cannon that fires directly before an aircraft takes off. This competition decreases the need for a new stationary sound system to be designed. A sound system installed at the ends of a runway that emits constant predatorial sound was considered, but the annoyance that this would cause for airport patrons and residents surrounding the airport eliminated this design.

A retractable apparatus with a mounted UV light system installed at various bird hotspots around the airport theoretically proved to be most realistic. Depending on the UV light frequency utilized in the system, birds could potentially see and be deterred by the system during the day and at night. Not only could this design be installed at the ends of the runway but it also could be installed in grass areas around the perimeter of the airport where birds tend to congregate. A UV light system capable of projecting 360 degree light would be most efficient for covering a larger portion of the airport. A design similar to a disco ball project UV light would be capable of projecting light at many angles around the radius of the apparatus. Prior to takeoff and landing, the UV light system would be raised from the ground and activated for a certain amount of time until the airport is cleared of potential bird hazards. The system can then be retracted back into the ground and the aircraft can safely land or takeoff. The biggest flaw with this concept is the fact that it is stationary and is therefore limited to the effective range of the UV light. This proposed design is simple, low cost and most importantly, effective.

Mobile Autonomous Airport Vehicle

Two of the most challenging aspects of warding off birds from the vicinity of an airport is the mobility of the birds themselves and their ability to adapt to certain predictable methods of deterrence. A stationary apparatus installed at an airport that is designed to ward off birds is limited in effectiveness due to its lack of mobility. Not only can birds simply relocate to another part of the airport away from the apparatus, but eventually they can get used to a predictable method that is immobile.

These problems with stationary methods for warding off birds is the reason why the mobile autonomous airport vehicle classification was created. Two fundamentally different concepts were used to create different design variations. These concepts differed based on the method of mobility.

The first concept is an autonomous ground vehicle that would utilize a UV light system and/or a sound emittance system. This vehicle, similar to a small remote control car, would be able to operate autonomously using an autonomous controller programmed with preloaded software. The software allows for an airport employee to program the vehicle's route based on the airport's flight schedule for that particular day. The vehicle would appear to be unpredictable to the birds because of the varying routes the vehicle would take each day. Most flocks of birds congregate in the grassy areas around the perimeter of the airport which is where the vehicle would spend most of its time patrolling. Utilizing a combination of UV light and sound emittance, the vehicle would be capable of getting extremely close to the birds, increasing the effectiveness of the light and sound greatly. The issue with the autonomous vehicle is that is limited to operating solely on the ground. Not only could the vehicle potentially interfere with the daily airport operations taking place on the ground, but there would also be certain areas around the airport that the vehicle could not reach.

The second concept is an autonomous drone that would also utilize a UV light system and/or a sound emittance system. In order to keep cost to a minimum, the drone would be based on a quadcopter design, the most basic drone design and reliable drone design manufactured today. The drone would operate autonomously using an autonomous flight controller with software that would allow an airport employee to program specific routes for the drone based on the airport's flight schedule for the day. The drone would appear to be unpredictable to birds because of the varying routes that the drone would take. In order for the drone to be as effective as possible, the software must allow the drone to hover and descend over certain points around the airport where birds congregate the most. Flight allows for maximum mobility, allowing the drone to get to spots around the area where a ground vehicle could not, such as areas just outside the fence. The combination of UV light and sound emittance would lead birds to associate the drone with a predator, deterring them from the airport grounds. The drone must be limited to operation that is not only FAA approved but also doesn't interfere with the operations occurring throughout the airport.

In order to keep the cost down of an autonomous vehicle/drone, there will be certain performance limitations for the vehicle/drone. The biggest limitation would be the range of the vehicle/drone. High performing batteries are expensive, meaning the vehicle/drone may not be capable of performing the longer routes that would be required around large commercial airports. Therefore, this autonomous vehicle/drone would be constructed to work at smaller general aviation airports.

Due to the versatile mobility of flight, the autonomous drone would be the best choice for warding off birds from airport grounds.

Design for Safety, Cost, Reliability

One of the most important design specifications was to make sure that the project adhered to FAA regulations. According to the FAA, the drone cannot fly faster than 100mph and must remain below a 400ft altitude. The drone must also not approach the runways as it could become a distraction to pilots. These regulations were easy to incorporate into the drone since the autopilot feature can be edited for all these factors. Using autopilot, a specific flight path could be created to keep the drone on the grassy areas surrounding the airport and away from the runways. Also, the altitude and speed can be changed to comply with FAA regulations.

With the given budget for the project, cost was another important design factor. The project had to be budgeted so that it would not exceed the five-hundred-dollar limit. Fortunately, after the fall semester, the team was given a drone to use that would have cost around \$600. This greatly helped decrease the costs in this project. Since the total material costs were only around \$125, the drone would be an inexpensive option for birdstrike prevention at airports.

To design for reliability and durability, all materials purchased had to be weather and impact resistant as the product would be working outside. The Raspberry Pi was placed inside a case before being attached to the drone so that water would not be able to get in. All materials were securely fashioned to the body of the drone so they would not fall off mid-flight.

Project Specific Details & Analysis

This project is specifically adhering to the guidelines of the Airport Cooperative Research Program Design Competition in order to be entered into the competition upon completion next semester. The ACRP Design Competition is open to university students across the United States and is funded by the Federal Aviation Administration. This Competition challenges individuals and teams of undergraduate and/or graduate students working with faculty advisors at U.S. colleges and universities to consider innovative approaches related to airport issues.

It was first necessary to determine what the focus of this potential project entry would be based on the given areas the ACRP provided. The ACRP Design Competition focuses on design solutions in the following broad areas: Airport Operation and Maintenance, Runway Safety/Runway Incursions/ Runway Excursions, Airport Environmental Interactions, and Airport Management and Planning. Teams are not limited to these options and can look for solutions to other problems that may fall outside of these categories. The potential entry for the competition described in this paper falls under the categories of Runway Safety and Airport Environmental Interactions.

Due to the fact that this design would be entered into a competition, it was important for the group to focus on an idea that hasn't already been researched extensively. Although there is quite a bit of information that already exists on the topic of bird strikes, there have yet to be any highly effective, efficient and ethical solutions. This led to the group's choice to pursue a design concept that focused on preventing bird strikes, specifically around small general aviation airports. It is crucial that this design meets all FAA regulations.

Partaking in the ACRP design competition means that there are provided guidelines for the competition. Some of these differ from those in the capstone course. A few of

these include a safety risk assessment, descriptions of interactions with airport operators and industry experts, and a specific format for the appendix of the report. The safety risk assessment is used to determine potential hazards that our design may present when operating on airport grounds. Introduction to Safety Management Systems for Airport Operators and FAA Safety Management System Manual in our analysis must be mentioned in the report. All of interaction with airport operators and experts must be explicitly documented, creating a log of all the contacts that have been reached out to and what was learned from them. The specified appendix is outlined in detail in the ACRP Design Competition Guideline booklet and includes contact information for all students on the team and all advisors that have helped with the project, a description of our university, a sign off sheet that must be signed by our capstone professor, and an evaluation that asks specific questions in order to improve the experience for future students.

Detailed Product Design

After deciding to pursue an autonomous drone to ward off birds around small/private airports, the project moved into the design phase. The preliminary design of the drone was completed during the first semester of the project. This initial design involved building a drone based on the DJI Flame Wheel F450 ARF Kit and purchasing the other necessary components such as the battery, flight controller and radio controller separately. Towards the conclusion of the first semester, Professor Nassersharif informed the group that he would provide a pre-built drone to use as a basis for the concept. This meant that the final product design changed from the preliminary design report.

The drone provided by Professor Nassersharif is a 3D Robotics Iris+, a quadcopter with full autonomous capabilities. The flight controller of the Iris+ utilizes the Pixhawk v2.4.5 autopilot software which is ideal for autonomous flight. Through this software, the drone can be programmed to fly a predetermined autonomous flight around a small/private airport perimeter, stopping at various points of interest to ward off birds. The Iris+ also includes a radio controller to operate the drone manually, a gimbal mount and an 8C 3S 5.1 Ah 11.1 V Lipo battery.

A majority of the design time was spent determining how a lighting and sound system could be integrated and controlled on the quadcopter. It was determined that the best way to control an onboard lighting and sound system would be using a Raspberry Pi computer. The Raspberry Pi 3 B+ was chosen for this application due to its powerful and responsive quad core 1.4 GHz processor, multiple USB ports, bluetooth capability and efficient power consumption. The Raspberry Pi would need to be mounted to the 3DR Iris+ and connected to the lighting and sound system in order to control them. With a few minor modifications to the provided gimbal mount and the purchased case

for the Raspberry Pi, the Raspberry Pi could be mounted to the bottom of the quadcopter.

The next step in the design process was determining how to power the on board Raspberry Pi. It was determined that adding an additional external power supply to supply power to the Raspberry Pi would not be ideal due to the additional weight. Therefore, it was decided that it would be necessary to power the Raspberry Pi using the same LiPo battery that powers the 3DR Iris+. In order to achieve this, a circuit needed to be designed that could provide the necessary power to both the Raspberry Pi and 3DR Iris+ from the provided LiPo power. The quadcopter required the full 11.1 V of power from the LiPo while the Raspberry Pi required the voltage to be dropped to 5 V for safe operation. In order to do this, a double jointed power converter was created utilizing XT60 connectors, 14 gauge electrical wire, heat shrink and a 5V 3A BEC. The power converter was soldered together to create the optimal power distribution. The LiPo battery connects via XT60, the 3DR Iris+ connects via the opposing XT60 to provide 11.1 V of power and the BEC drops the voltage to 5 V and connects to the Raspberry Pi 3 B+ via 5V GPIO pins 4 and 6.

With the Raspberry Pi mounted and the power converter assembled, the next step in the design process was determining how to mount a lighting and sound system to the quadcopter. A UV light strip with a specific frequency that birds associate with predatory behavior was chosen for the lighting system. This light strip was cut to the exact length necessary to wrap around the four arms of the quadcopter. The strip was mounted to the 3DR Iris+ using zip ties to avoid making any major modifications to Professor Nassersharif's drone. The light strip is powered by connecting the strip to the Raspberry Pi via USB. For the sound system, it was decided that the best option would be to use a small bluetooth speaker that could be mounted to the drone. In order to minimize the impact on the quadcopter's flight dynamics, the speaker is mounted to the

exposed side of the Raspberry Pi's case on the underside of the quadcopter. The speaker is adhered to the case using a high strength epoxy.

The main functionality of the onboard Raspberry Pi is to control both the onboard lighting and sound system. The UV light strip is powered via a USB port on the Raspberry Pi. Research shows that flashing UV lights would be most effective for deterring birds. To achieve this, a script was written on the Raspberry Pi's console to constantly cut power from the USB ports which created the desired flashing effects. The script is set to execute on startup and loops every 0.125 seconds. As soon as the Raspberry Pi begins to receive power, the script is executed. This negates the need for the Raspberry Pi to be connected to an external monitor to setup and run the script. The bluetooth capabilities of the Raspberry Pi are used to connect to the bluetooth speaker. A 15 minute long audio file of looping predatorial noise (based on the location of where the quadcopter is operating) was uploaded to the Raspberry Pi. A script was written on the Raspberry Pi's console to connect the speaker via bluetooth and play the audio file on startup. Like the lighting system script, executing the script to connect the bluetooth speaker and play the audio file on startup eliminates the need to connect the Raspberry Pi to an external monitor to setup and run the sound system script.

In order to make the drone autonomous, flight paths were created and downloaded onto the Pixhawk flight controller. The Mission Planner application for Windows functioned as a ground station for the drone. This provided the system with a multitude of configuration and dynamic control features that were adjusted to meet our specific design specifications. The Mission Planner did not have to be connected to the drone in order to create the flight path. Under the flight plan tab, a flight path for the drone was created using four waypoints. At each of these waypoints, certain commands were implemented to effectively cover the specific flight path area. Right-clicking on the flight plan screen and scrolling down to "File Load Save" allowed for the flight path to be

downloaded onto the PC. In order to load the flight plan onto the drone, the PC and the drone needed to be connected using the Sik Telemetry Radios.

These SiK Telemetry Radios came with the drone that Professor Nassersharif provided for the team. One Sik Radio connects to the Pixhawk “Telem 1” via the 6 pin DF13 connector, which was already internally installed on this drone. This Sik Radio is also referred to as the “Remote Module.” The second Sik Radio, also referred to as the “Local Module,” connected to the PC via micro USB cable. This connection installed the appropriate driver automatically to the PC. On Mission Planner, under the comport drop down box, COM3 was selected and the baud rate was changed to 57600. On the far right of the Mission Planner screen, the “Connect” button was pressed. A solid green LED light from the Local Module indicated a connection with the drone. This then allowed for the loading of the flight path to the drone.

3D Robotics Iris+

Specifications

Autopilot:	Pixhawk v2.4.5
Firmware:	ArduCopter 3.2
GPS:	3DR uBlox GPS with Compass (LEA-6H module, 5 Hz update)
Telemetry radio:	3DR Radio Telemetry v2 (915 mHz or 433 mHz)
Motors:	920 kV
Frame type:	V
Propellers:	9.5 x 4.5 T-Motor multirotor self-tightening counterclockwise (2) 9.5 x 4.5 T-Motor multirotor self-tightening clockwise (2)
Battery:	3S 5.1 Ah 8C lithium polymer
Low battery voltage:	10.5 V
Maximum voltage:	12.6 V
Battery cell limit:	3S

IRIS is compatible with 3S lithium polymer batteries only.
Using a 4S battery can cause permanent damage to the gimbal electronics and will void the warranty.

Payload capacity:	400 g (.8 lbs)
Radio range:	up to 1 km (.6 miles)
Flight time:	16-22 minutes, depending on payload

Table 2: 3DR Iris+ Manufacturer Specifications

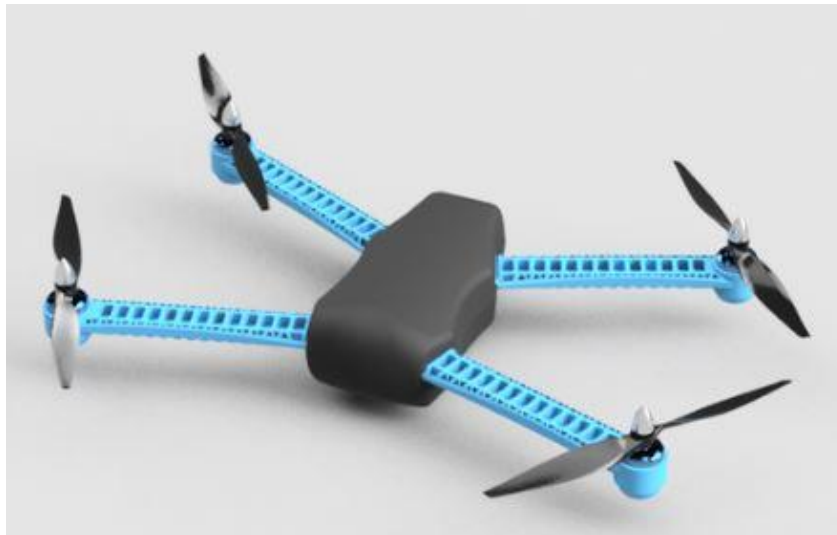

Figure 20: CAD Image of 3DR Iris+

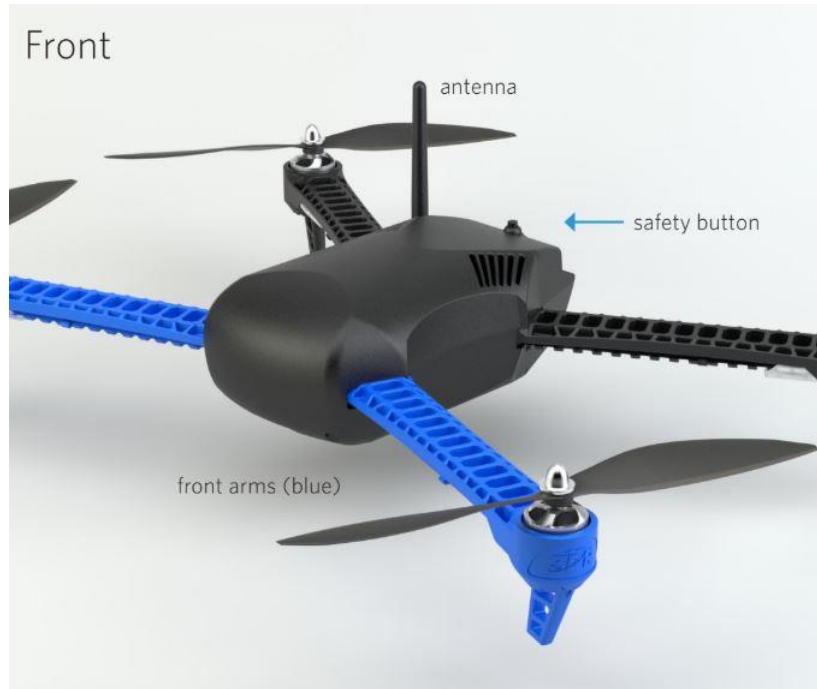

Figure 21: Front Image of 3DR Iris+

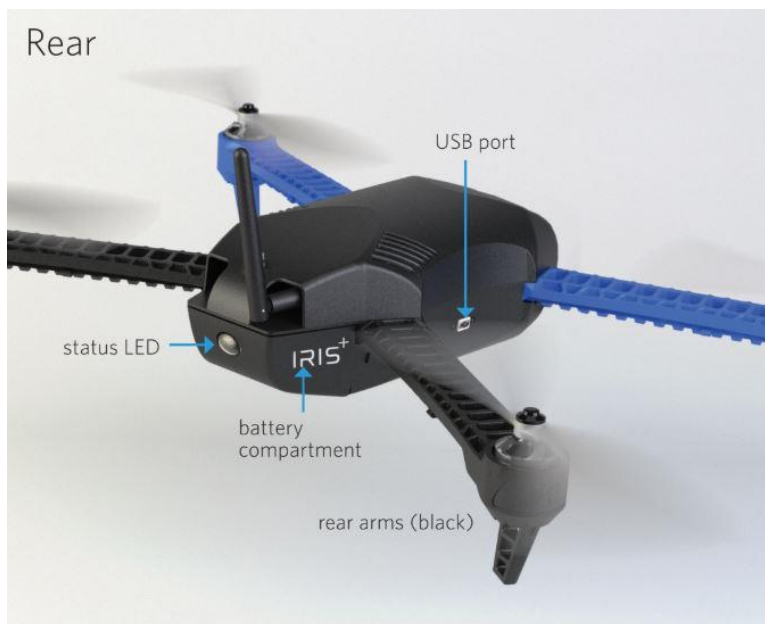

Figure 22: Rear Image of 3DR Iris+

Raspberry Pi 3 B+

Raspberry Pi 3B+ specifications

- SoC: Broadcom BCM2837B0 quad-core A53 (ARMv8) 64-bit @ 1.4GHz
- GPU: Broadcom Videocore-IV
- RAM: 1GB LPDDR2 SDRAM
- Networking: Gigabit Ethernet (via USB channel), 2.4GHz and 5GHz 802.11b/g/n/ac Wi-Fi
- Bluetooth: Bluetooth 4.2, Bluetooth Low Energy (BLE)
- Storage: Micro-SD
- GPIO: 40-pin GPIO header, populated
- Ports: HDMI, 3.5mm analogue audio-video jack, 4x USB 2.0, Ethernet, Camera Serial Interface (CSI), Display Serial Interface (DSI)
- Dimensions: 82mm x 56mm x 19.5mm, 50g

Figure 23: Raspberry Pi 3 B+ Specifications



Figure 24: Raspberry Pi 3 B+

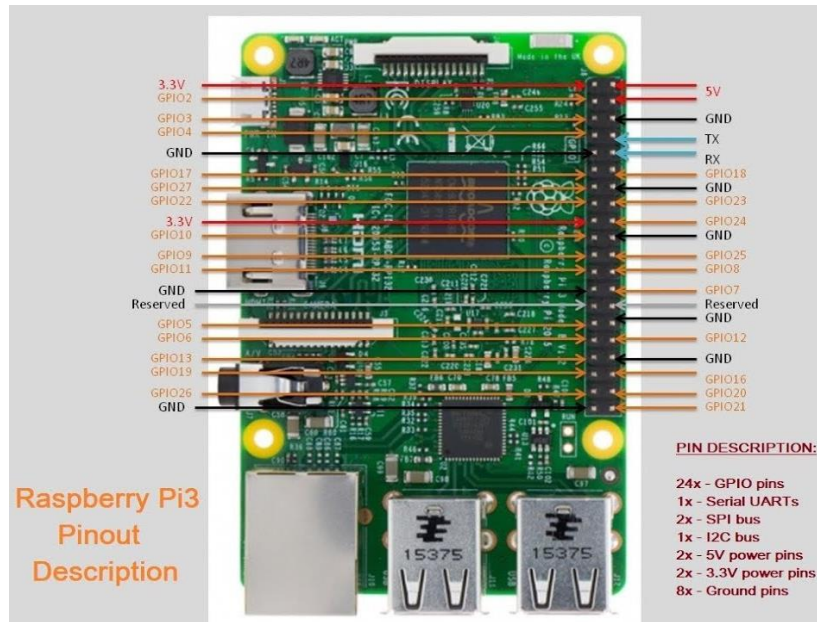

Figure 25: Raspberry Pi 3 B+ GPIO Directory



Figure 26: Raspberry Pi 3 B+ In Case

Programmed Scripts

1. Create a file for your startup script and write your script in the file:

```
$ sudo nano /etc/init.d/superscript
```

2. Save and exit: `Ctrl` + `X`, `Y`, `Enter`

3. Make the script executable:

```
$ sudo chmod 755 /etc/init.d/superscript
```

4. Register script to be run at startup:

```
$ sudo update-rc.d superscript defaults
```

Figure 27: Commands to run script on startup

To shut off power on USB ports (this shuts power on ethernet as well):

```
echo '1-1' | sudo tee /sys/bus/usb/drivers/usb/unbind
```

To turn power back on

```
echo '1-1' | sudo tee /sys/bus/usb/drivers/usb/bind
```

Figure 28: Commands to shut off/turn on USB power

Power Converter

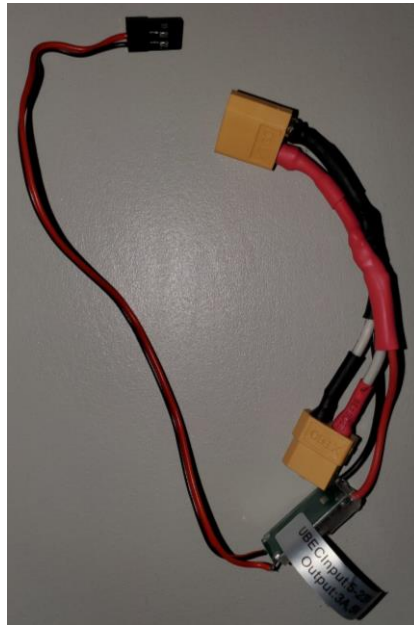

Figure 29: Double Jointed 12V/5V Power Converter

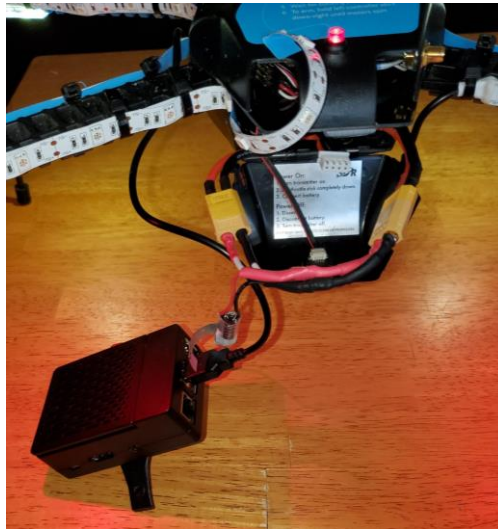

Figure 30: Power Converter Connected to 3DR Iris+ and Raspberry Pi 3 B+

Fully Assembled Quadcopter



Figure 31: Fully Assembled Quadcopter with UV Lighting On



Figure 32: Fully Assembled Quadcopter

Autonomous Flight



Figure 33: Mission Planner Interface



Figure 34: Sik Telemetry Radio

Engineering Analysis

Mass Analysis of Quadcopter

In order to verify that the quadcopter will fly, it is important to first consider the total mass of the system.

Part	Mass (g)
3DR Iris+ with LiPo Battery	1282.00
Raspberry Pi 3 B+	58.97
Raspberry Pi 3 B+ Case	49.90
Bluetooth Speaker	175.77
Power Converter	27.80
UV Light Strip	65.20
Total Mass of System	1659.64

Table 3: Total Mass of Quadcopter (Fully-Equipped)

As seen from table 3, the total mass of the quadcopter with all parts assembled is 1659.64 grams. The maximum recommended takeoff mass provided by 3D Robotics is 1682 grams (maximum recommended payload of 400 grams). This means that the quadcopter as currently assembled falls below the maximum manufacturer recommendation by 22.36 grams (total payload of 377.64 grams). This maximum value

is calculated by the manufacturer based on the strength of the airframe and the power produced by the four motors. Staying below this value ensures that the airframe will be able to withstand this load without any issues. Knowing the total mass of the quadcopter, the thrust to weight analysis can now be completed.

Thrust Analysis

Now that the total mass of the fully-equipped quadcopter is known, the thrust to weight ratio can be determined. The first step to this process is to determine the force acting on the quadcopter due to gravity. The equation for force due to gravity is shown below:

$$F = mg \quad (i)$$

F is the force due to gravity in newtons, m is the total mass of the quadcopter (1659.64 g) and g is the gravitational constant (approximately $9.81 \frac{m}{s^2}$). Plugging in these values into the equation, it is determined that the force due to gravity on the quadcopter is equal to 16.28 newtons. This value represents the force that the quadcopter must overcome in order to takeoff from the ground.

The *static thrust* must now be calculated in order to compare it to the force due to gravity to determine if the quadcopter will generate enough thrust to lift off of the ground. Static thrust is defined as the amount of thrust produced by a propeller which is located stationary to the earth. It is generally considered that the ratio between the static thrust produced by all four propellers over the force due to gravity should be approximately 2:1 for sufficient performance. For the purpose of this quadcopter, it is imperative that its performance exceeds this value to ensure that the quadcopter will be able to not only go from point to point with no problems, but also hover, descend and ascend repeatedly over a specified point. An approximation of static thrust produced by one propeller can be calculated using an equation derived specifically to be used for

drones (9). The following equation approximates the static thrust produced by one propeller at maximum propeller RPM:

$$F = (4.392399 \times 10^{-8})[RPM_{prop} \times \frac{d^{3.5}}{\sqrt{pitch}} (4.23333 \times 10^{-4}) \times RPM_{prop} \times P - v_0] \quad (ii)$$

F is the static thrust in newtons, RPM_{prop} is the maximum RPM of the propeller, P is the pitch of the propeller in inches, d is the diameter of the propeller in inches and v_0 is the forward velocity of the quadcopter in inches per second. In this case, the forward velocity of the quadcopter is equal to 0 inches per second because the static thrust is being calculated. In order to utilize equation ii, some variables above must be first determined.

The maximum RPM of the propeller is calculated using the following equation:

$$RPM_{prop} = (KV)(V) \quad (iii)$$

Where KV is the RPM constant of the motor ($920 \frac{RPM}{volt}$) and V is the voltage provided by the battery (11.1 V). Plugging in these values into the equation, it is determined that the maximum RPM of the propeller is 10,212 RPM.

The diameter and pitch of the propeller are given by the manufacturer of the 3DR Iris+. The diameter of the propeller is 9.5 inches and the pitch of the propeller is 4.5 inches. With all these values now known, the estimated static thrust produced by one propeller can now be calculated using equation (ii). Plugging in these values into the equation, it is determined that the static thrust produced by one propeller is 10.87 newtons. Accounting for all four propellers on the quadcopter setup, the static thrust produced by one propeller can be multiplied by four to give the total static thrust produced by all four

propellers. It is then determined that the total static thrust produced by all four motors is 43.48 newtons.

The static thrust produced by all four motors can now be compared with the force due to gravity. The ratio between static thrust over force due to gravity is approximately 2.7:1 which will yield excellent quadcopter performance. 43.48 newtons of static thrust is more than enough to overcome the 16.28 newtons of force acting on the quadcopter due to gravity, allowing for low stress takeoffs and excellent performance in the air.

Flight Time Analysis

The flight time of the quadcopter is crucial when considering its application. In order to perform a complete route around a small general aviation airport perimeter, it was estimated that a flight time of approximately 10 minutes should be sufficient. Choosing the correct battery for the purpose of the quadcopter comes down to a few important calculations.

The battery provided for this project is the 3DRobotics 8C 3S 5100mAh 11.1V Lipo Battery. A LiPo battery consists of multiple cells. These cells deliver approximately 3.7 volts to the system. A 3S LiPo battery consists of three cells. Therefore the 3S LiPo battery chosen for this project will supply 11.1 volts to the system. The higher the cell count, the better the battery will be at maintaining consistent performance. An increased cell count tends to add more weight to the battery, so it was determined that the added performance of a 4S battery was not justified.

The *C-Rating* of a battery refers to how quickly a battery can discharge energy. The C-Rating of this specific battery is 8C. The battery's maximum discharge rate can be calculated using the equation below:

$$\text{Max. Discharge Rate} = A \times C \quad (\text{iv})$$

A is the battery's total capacity in amp-hours (5.1 Ah) and C is the battery's C-Rating (8C). Substituting these values into the above equation yield a maximum discharge rate of 40.8 amps.

Of course, the drone will not be constantly operating at its maximum discharge rate. This means that the average amp draw, or the average amount of amps being discharged from the battery, needs to be calculated:

$$AAD = m_T \times \left(\frac{P}{V}\right) \quad (\text{v})$$

AAD is the average amp draw of the battery in amps, m_T is the total mass of the quadcopter in kilograms (1.65964 kg), V is the voltage supplied by the battery in volts (11.1 V) and P is the power required to lift 1 kilogram of equipment in watts per kilogram. For the purpose of this estimation, P was set equal to a conservative estimate of 120 W/kg. Substituting these values into the equation above yielded an average amp draw of 17.94 amps.

With all of these values now solved for, the estimated flight time of the quadcopter can now be calculated using the following equation:

$$t = \frac{C_B \times D}{AAD} \quad (\text{vi})$$

t is the estimated flight time in hours, C_B is the capacity of the battery in amp-hours (5.1 Ah), AAD is the average amp draw in amps (17.94 A) and D is the battery discharge allowed during flight. As LiPo batteries can be damaged if fully discharged, it's common practice never to discharge them by more than 80%. Therefore, the discharge will be

set to 80% for this calculation. Substituting in all of these values into the above equation, it is determined that the estimated flight time of the quadcopter will be 0.227 hours or 13 minutes and 39 seconds.

Build/Manufacture

Build

Prototype

The team created a fully operational prototype that is equipped with lighting and sound functionality specifically implemented to deter wildlife, namely birds, from fields on or near airport grounds. The prototype consists of a base drone, the Iris+ 3DR, with various modifications and additions. Ultraviolet lighting was added to the arms of the drone in the form of a USB light strip, a Raspberry Pi was mounted underneath the drone, a Bluetooth speaker was mounted onto the Raspberry Pi case using an epoxy, and the battery connection to the drone was split so as to power the drone and Raspberry Pi simultaneously. The Raspberry Pi is used to regulate the lighting and sound through code and also functions as a conduit to power the USB light strip.

Verification of Function

Various tests confirmed that the drone is functional and semi-autonomous in operation. The additional components added did not create so substantial a payload that the drone could not maneuver, in fact the maneuverability seemed unchanged when remotely controlled and when using the Mission Planner. Flight time exceeded expectations even with the additional payload, surpassing the ideal 10-minute mark by 1 minute and 37 seconds. This accounts for a 16.2% longer battery life than considered necessary. The automated flight planner was able to create a predetermined route that the drone then executed. In general, the functionality of the drone is within expectations. Future testing is required to see quite how effectively the current design is able to ward off birds from the fields adjacent to airport grounds.

Manufacture

Raw Materials

As the group was already provided with a prebuilt 3DR Iris+, there were no raw materials required to construct the drone itself. Most of the raw materials utilized in this project were used when manufacturing the power converter below. Additional materials include zip ties, epoxy, and five #2 ¼ inch brass screws.

Power Converter

There were several materials necessary in order to manufacture the power converter. These materials include a male and female XT60 connector, a 3A 5V BEC, 14 gauge electrical wire, heat shrink and soldering equipment. Once the initial design for the power converter was drawn up, the prototype double-jointed circuit was soldered together and wrapped with heat shrink. After some initial testing, the power converter was cut down and shortened at the XT60 connector to provide easier integration of the converter on the 3DR Iris+.

Prototype Assembly and Mounting

The Iris+ 3DR, used as the centerpiece for the design, was the base to which the various components were mounted. This includes the ultraviolet light strip, the Raspberry Pi B+ and the EWA 106 Bluetooth speaker. This section will describe in detail how these components were mounted.

The light strip purchased was approximately the perfect length to encircle the perimeter of the drone's arms. This perimeter was just under 6 ft. The strip could be glued to the arms, but to prevent permanently modifying a drone which did not belong to us, zip ties were used at various points along the arms of the drone to secure the lights. The arms of the drone have holes to improve strength and minimize weight; zip ties were looped through these holes and around the light strip to fasten the strip to the arm.

Approximately 6 zip ties were required per arm, for a total of 24 utilized. This simplistic way of mounting the lights was not visually appealing but was cost effective and practical given the circumstances of ownership of the drone.

The Raspberry Pi was mounted underneath the body of the drone using the camera mount that was included in the base package of the Iris+ at purchase by the university. Originally mounted to a gimbal that supported rotation of a camera, the plastic mount was repurposed as a mount for the Raspberry Pi. This was done by first removing the camera and gimbal from the plastic mount then boring 5 holes in the Raspberry Pi case that align with the holes already bored in the plastic mount. Lastly, the proper sized screws were purchased and the mount was fixed to the case. The ¼ inch screws penetrate inside the case, and as a result had to be filed down as a precaution to avoid damaging the internal components of the Pi. To complete the mounting process, 2 hex key screws are used to fasten the plastic mount to the body of the drone. An image of the plastic mount fixed to the Raspberry Pi case is pictured below.



Figure 35: Gimbal mount/Raspberry Pi assembly

The last component that needed to be mounted was the EWA A106 Bluetooth speaker. Originally this was mounted temporarily using zip ties. The intention of the team was to design a 3D printed mount for the speaker that would fasten to the underside of the Raspberry Pi case in the same way that the plastic gimbal mount was fixed to the topside of the case. With limited time and many things to accomplish the team allocated its resources elsewhere and determined that using an epoxy to mount the speaker to the case was the better alternative. This functioned as a semi-permanent mount that could be used in the interim until, if time was available towards the end of the semester, the 3D printed mount could be realized. This never came to fruition, however, and the epoxy adhesion became the final version. This epoxy was applied to the plastic and rubber on one surface of the speaker and fixed to the underside of the Raspberry Pi case. It was left to set for 48 hours to ensure a strong bond.

Software Coding

As mentioned in the product design, the onboard Raspberry Pi executes specified scripts in order to control both the lighting and sound systems. The UV light strip mounted to the 3DR Iris+ is powered by connecting to one of the USB ports on the Raspberry Pi. A script was written on the Raspberry Pi's console that constantly cuts power to the USB ports and then turns the power back on. This script loops every 0.125 seconds in order to create the desired flashing effect from the UV light strip. To reduce setup time upon operation of the drone, the script is programmed to execute on startup (as soon as the Raspberry Pi receives power), therefore no external monitor is needed to run the script.

The Raspberry Pi is also programmed to automatically connect to the Bluetooth speaker and play an audio file comprised of predatory noises that was uploaded onto its hard drive. This requires the user of the Raspberry Pi to write a code that will allow the Bluetooth speaker to be identified and a connection established soon after the Raspberry Pi is powered on. An additional code is also ran on startup that will select a specific mp3 file to output to the Bluetooth speaker.

Testing

Several different tests were performed to determine the efficiency of the drone as well as its durability. The tests and their parameters can be seen in the testing matrix table below:

Variables/Components	What to test?	Test parameters	Variables/Components	What to test?	Test parameters
Sound	Efficacy*		Weather	Durability	
Lighting	Efficacy*		Mounts	Durability	
Flight speed	Efficacy*	100 mph per FAA regulations	Battery/ Flight time	Reliability	limited by battery size and payload weight
Flight height	Efficacy*	400 ft per FAA regulations	Power Splitter	Durability/ Reliability	
Time of day	Efficacy*		Payload Weight	Reliability	400g max
Bird type	Efficacy*		Speaker (battery life)	Reliability	approx. 4 hours
Sound intensity	Efficacy*	limited by max. speaker output	Speaker (bluetooth range)	Reliability	approx. 33ft

*Efficacy of deterring birds

Table 4: Testing Matrix

The most important test performed was the flight time analysis. Ideally, the drone would operate for at least ten minutes fully equipped to give it enough time to fly a route around a small airport. For the first test, the drone was flown unequipped and hovered in one location until the battery ran out. The unequipped flight time was 17 minutes and 23 seconds. This value was just under the calculated flight time of 17.66 minutes. For the next test, the drone was flown fully equipped. The flight time for this test was 11 minutes and 37 seconds. This value produced more of an error with the theoretical flight time being 13.64 minutes. One reason for this error could be that the power consumption from the Raspberry Pi was not included in the theoretical calculation. However, the goal was achieved since the flight time was greater than the goal of ten minutes.

Other important tests for the project were the operation time for the speaker and the UV lights. Running through the Raspberry Pi, the lights ran continuously for over 23 hours while the speaker ran for 6 hours. These results do not affect the efficiency of the drone since the equipment can operate much longer than the flight time of the drone.

Testing for durability and reliability of the drone is difficult since not all weather conditions were available to test in. However, the drone was tested in windy weather as well as rain and was able to take off, fly, and land without any difficulty. The drone is also able to withstand a significant impact without being damaged.

Overall, testing the project was successful. The drone is durable and is able to fly for enough time to patrol an airport on one battery. The drone was tested in a wide open field and all birds in the area were scared off by the flying drone.

Redesign

At the conclusion of the first semester, the project's design was vastly different from the final design described in this report. The preliminary design concept focused on building a custom drone to deter birds based on the DJI Flame Wheel F450 ARF Kit. This required the purchase of all the necessary components to build a custom drone on top of the additional components that would be implemented specifically to ward off birds around the perimeter of a small/private airport. Professor Nassersharif instead decided to allow the group to use a pre-built drone provided by the University of Rhode Island, the 3D Robotics Iris+. This allowed for the project to shift more of its focus towards the components necessary to deter birds rather than allocating most of the time designing and building a drone. The alteration from designing a custom drone to utilizing a pre-built 3DR Iris+ was the first major redesign in this project.

The build and test presentation required the group to review and analyze the data collected from the initial testing of the quadcopter. One of the major focal points of the initial testing was determining the flight time the quadcopter could achieve when fully equipped with all the bird deterrence components. This test was conducted by setting the drone to loiter (LTR) mode and hovering the drone over one location. The time from when the motors were armed to when the quadcopter reported low battery was recorded as the fully equipped flight time. Initially, 10 minutes of flight time was decided to be sufficient for this quadcopter's intended usage. After completing the test, it was discovered that the quadcopter was able to sustain 11 minutes and 37 seconds of flight when fully equipped. This was a positive result, however the test was not an accurate representation of the quadcopter's desired workload.

The original plan was to test the flight path of the drone at Quonset airport. The quadcopter would have flown an autonomous route around the perimeter of the area shown below in figure X or where wildlife, specifically birds, tend to linger. To get a more

accurate value for the flight time of the fully equipped quadcopter, a redesign of the original flight test would have been required. Utilizing the 3DR Iris+ Pixhawk v2.4.5 autonomous flight controller with the Mission Planner application for Windows, an autonomous route was created to make a more accurate flight time test for the quadcopter. Unfortunately, the team was not able to make direct contact with Quonset airport in order to finalize this specific part of the project.

Autonomous Flight

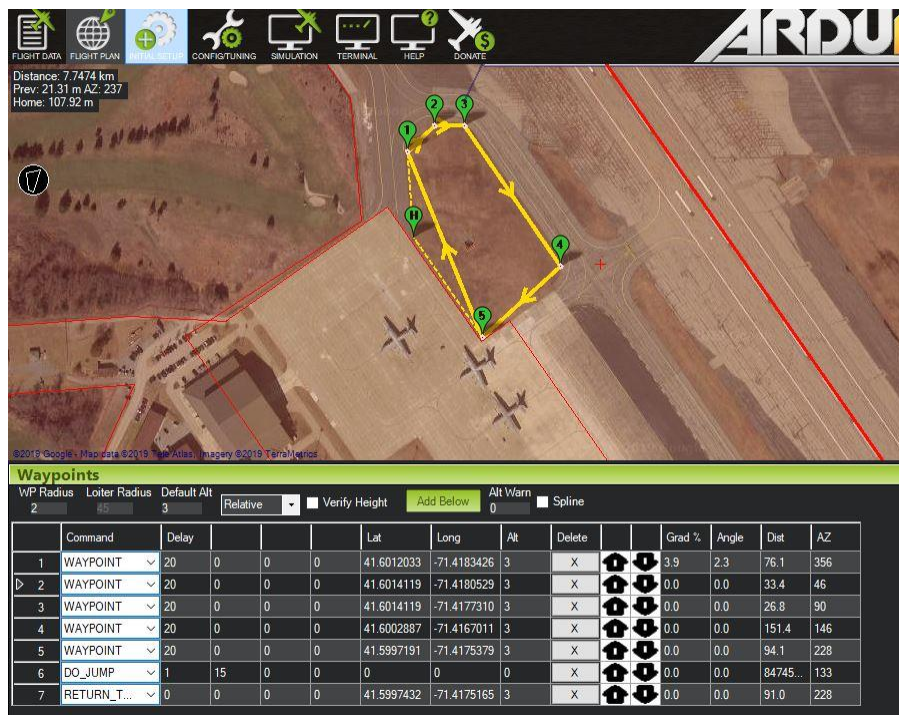

Figure 36: Mission Planner Interface

Project Planning

A project plan was created using Microsoft Project to outline all of the deadlines for this semester. The completed project plan can be seen below.

ID	Task Mode	% Complete	Task Name	Duration	Start	Finish	Predecessors
1	✓	100%	Introduction	1 day	Wed 1/23/19	Wed 1/23/19	
2	✓	100%	Orientation for Spring Semester	1 day	Wed 1/23/19	Wed 1/23/19	
3	✓	100%	Team Work	1 day	Fri 1/25/19	Fri 1/25/19	1
4	✓	100%	Project Work	1 day	Fri 1/25/19	Fri 1/25/19	
5	✓	100%	Test Engineering 1	1 day	Wed 1/30/19	Wed 1/30/19	3
6	✓	100%	Lecture on test engineering	1 day	Wed 1/30/19	Wed 1/30/19	
7	✓	100%	Team work	1 day	Fri 2/1/19	Fri 2/1/19	5
8	✓	100%	Project Work	1 day	Fri 2/1/19	Fri 2/1/19	
9	✓	100%	Test Engineering 2	1 day	Wed 2/6/19	Wed 2/6/19	7
10	✓	100%	Lecture on test engineering	1 day	Wed 2/6/19	Wed 2/6/19	
11	✓	100%	Team Work	1 day	Fri 2/8/19	Fri 2/8/19	9
12	✓	100%	Project Work	1 day	Fri 2/8/19	Fri 2/8/19	
13	✓	100%	Other Considerations 1	1 day	Wed 2/13/19	Wed 2/13/19	11
14	✓	100%	Lecture on other considerations, Engineering ethics, Professional	1 day	Wed 2/13/19	Wed 2/13/19	
15	✓	100%	Team Work	1 day	Fri 2/15/19	Fri 2/15/19	13
16	✓	100%	Project Work, Order materials	1 day	Fri 2/15/19	Fri 2/15/19	
17	✓	100%	Other Considerations 2	1 day	Wed 2/20/19	Wed 2/20/19	15
18	✓	100%	Lecture on other considerations	1 day	Wed 2/20/19	Wed 2/20/19	
19	✓	100%	Team Work	1 day	Fri 2/22/19	Fri 2/22/19	17
20	✓	100%	Project Work	1 day	Fri 2/22/19	Fri 2/22/19	
21	✓	100%	Engineering Ethics	1 day	Wed 2/27/19	Wed 2/27/19	19
22	✓	100%	Lecture on engineering ethics, Professional registration	1 day	Wed 2/27/19	Wed 2/27/19	
23	✓	100%	Team Work	1 day	Fri 3/1/19	Fri 3/1/19	21
24	✓	100%	Project work	1 day	Fri 3/1/19	Fri 3/1/19	
25	✓	100%	Design Showcase	1 day	Wed 3/6/19	Wed 3/6/19	23
26	✓	100%	Lecture on brochures, posters, and design showcase	1 day	Wed 3/6/19	Wed 3/6/19	
27	✓	100%	Team Work	1 day	Fri 3/8/19	Fri 3/8/19	25
28	✓	100%	Project work, Prepare for build/test, Start presentation	1 day	Fri 3/8/19	Fri 3/8/19	
29	✓	100%	Build/Test Review	8 days	Wed 3/20/19	Fri 3/29/19	27
30	✓	100%	Build/Test Review	8 days	Wed 3/20/19	Fri 3/29/19	
31	✓	100%	Team Presentations	8 days	Wed 4/3/19	Fri 4/12/19	29
32	✓	100%	Team Presentations - Build and Test	8 days	Wed 4/3/19	Fri 4/12/19	
33	✓	100%	Showcase Preparation	6 days	Wed 4/17/19	Wed 4/24/19	31
34	✓	100%	Showcase Preparation	6 days	Wed 4/17/19	Wed 4/24/19	
35	✓	100%	Design Showcase	1 day	Fri 4/26/19	Fri 4/26/19	33
36	✓	100%	Design Showcase	1 day	Fri 4/26/19	Fri 4/26/19	
37	✓	100%	Final Report	1 day	Mon 5/6/19	Mon 5/6/19	35
38	✓	100%	Final Report Due	1 day	Mon 5/6/19	Mon 5/6/19	

Figure 37: Project Plan

Microsoft Project creates a list of tasks with their start and end times and completion percentage. Using the project plan, Microsoft Project creates a Gantt chart which is a visual way to show the deadlines. The Gantt chart is shown in the following figure.

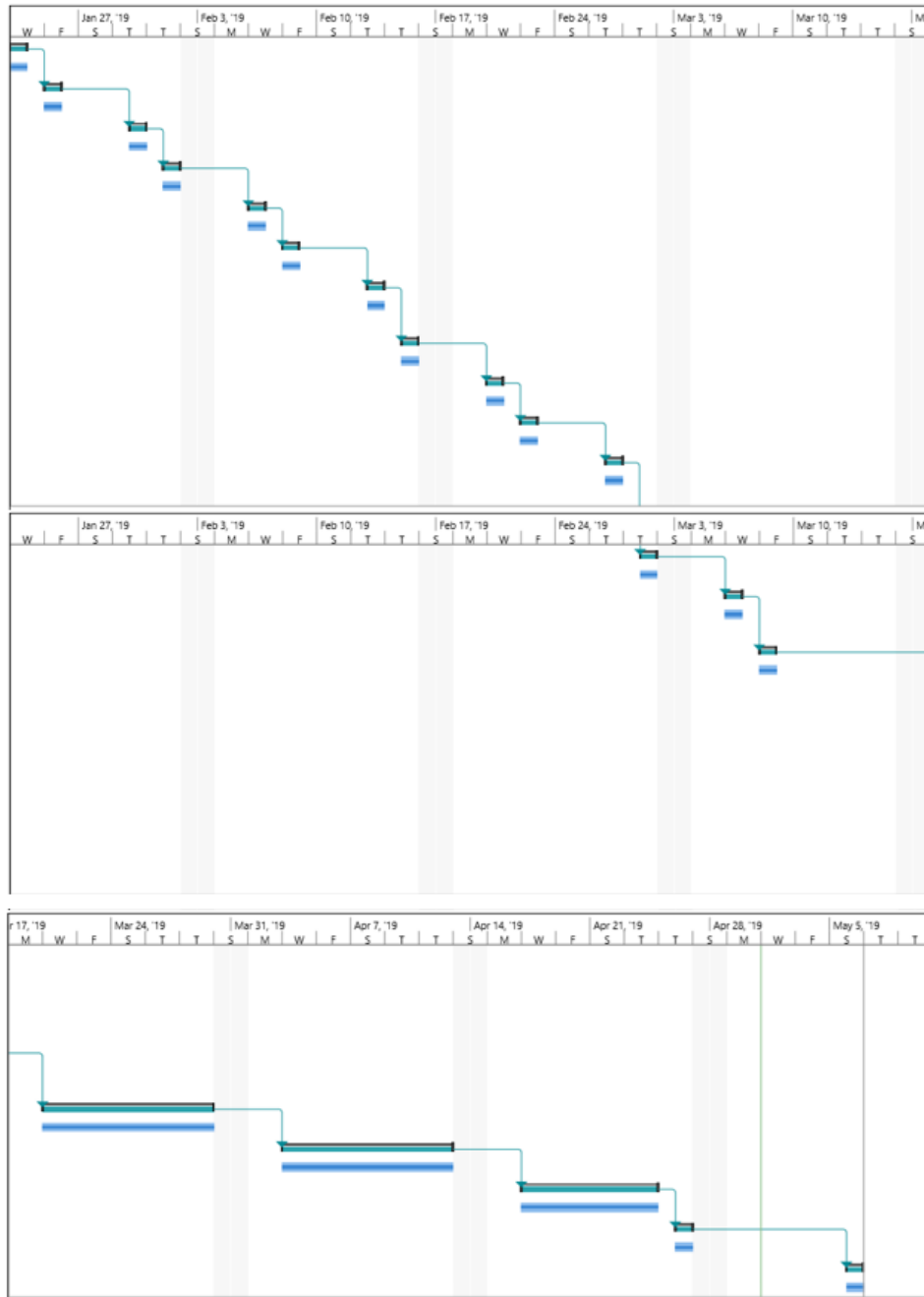

Figure 38: Gantt Chart

A larger image of the Gantt chart can be found in the appendices. The first phase of the semester was to decide on the best method for executing the design of the project. Once this was accomplished, testing could begin to be conducted. Next, the team had to prepare for the build test review and then compile all progress made thus far for the build and test presentation. Then the team had to prepare a poster and a brochure for the design showcase. The final task for the semester was to create this final design report summarizing all of the work done this semester.

Financial Analysis

After deciding to fully pursue the design of an autonomous drone intended to ward off birds from airport grounds, it was initially thought that the best route would be to build a drone based on the DJI Flame Wheel F450 ARF Kit. This concept was scrapped when the group was given a 3DR Iris+ from Professor Nassersharif. The bill of materials below represents the total cost of the items purchased to complete the final design of the project.

Item	Cost (Shipping Included)
STEADYGAMER - 32GB Raspberry Pi Preloaded (NOOBS) SD Card 3B+ (Plus), 3B, 2, Zero Compatible with All Pi	\$22.99
Canakit 5V 2.5A Raspberry Pi 3 B+ Power Supply	\$9.99
iUniker Raspberry Pi 3 B+ Case, Raspberry Pi Fan ABS Case With Cooling Fan, Raspberry Pi Heatsink, Simple Removable Top Cover	\$10.99
BW® RC Servo BEC UBEC 3A 5V for Helicopter Airplane Receiver Servo Power Supply	\$8.99
Element14 Raspberry Pi 3 B+ Motherboard	\$38.10
Finware XT60 XT-60 6 Pair Connectors Male Female bundled with 5mm Heat Shrink Tubing (red and black)	\$6.99
Wireless Mini Bluetooth Speaker with Custom Bass Radiator. EWA A106	\$16.99
DeepDream Black Light UV Led Strip 16.4Ft/5M 24W Flexible Waterproof IP65 with 12V 2A Power Supply	\$9.99
Total	\$125.03

Table 5: Bill of Materials

Taking a look at the final bill of materials, it is clear that the total cost of this project falls well below the given budget of \$500. When including the estimated cost of the 3DR Iris+ (~\$600), the total cost of the assembled quadcopter excluding labor costs is \$725.03. Below is a pie chart that displays the allocation of funds to each part of the project.

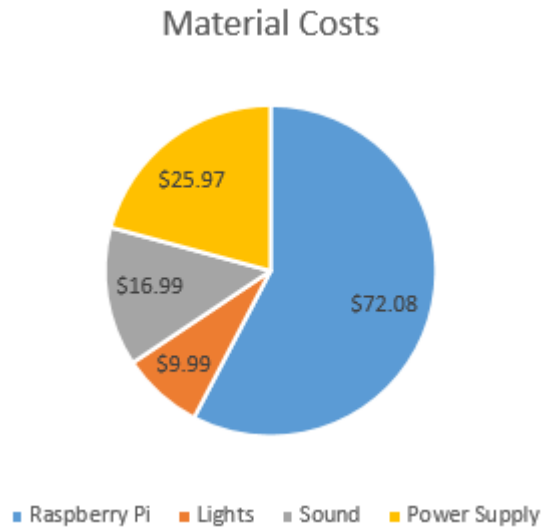

Figure 39: Material Costs Pie Chart

Operation

Automated Operation

This device, if fully idealized, would be entirely autonomous and would operate without the need for intervention by an airport employee. The autopilot software allows for all flight operations to be controlled without user input after pre-flight initialization. The drone is programmed to track a predetermined perimeter route and land itself back at the point of takeoff. The light and sound emission is designed to begin when the Raspberry Pi is powered (i.e. when the battery is plugged into the power converter) and is fully automated. However, the current status of the prototype does not allow for fully automated functionality due to limitations in the design. The battery must be manually switched out and charged, the pre-flight checklist must be followed and takeoff must be initiated by arming the motors via the transmitter and device maintenance must also be conducted.

Pre-flight Initialization

A detailed description of the initialization procedure for the flight plan data onto the drone flight controller is enumerated in the Detailed Product Design section of this report. To avoid redundancy only the major points will be highlighted here. Prior to a perimeter flight, the specified flight path must be created and synced with the flight controller using the telemetry radios. After the flight plan has been synced, a green light will indicate a successful transfer of data. The drone is then able to complete this flight path repeatedly without the need for further syncing to the Mission Planner. If the airport utilizing the drone kept the same flight route for its entire lifespan, there would never be need to repeat this process again. However, if the airport personnel wished to alter the flight path in the future this step must be repeated. Following this step, the drone must manually placed in the specified takeoff location.

Pre-flight Checklist and Takeoff

The Iris+ 3DR has a specific pre-flight checklist that must be followed in order for successful operation. This process is detailed in the Operation Manual that is included upon purchasing the drone from the manufacturer. The process must be followed precisely or the drone may not function properly. The process includes attaching the Iris+ antenna and orienting it vertically, tightening the propellers, ensuring that the left stick on the transmitter is pointing downwards, and that the switches on the transmitter are on AUTO mode. Following this the transmitter is powered on and the LiPo battery is plugged into the power converter to power the Raspberry Pi and the drone simultaneously. A safety button on the top of the drone must then be pressed manually and once GPS signal has been acquired the motors can be armed on the transmitter and the automated flight path will then be executed upon takeoff.

Maintenance

The great benefit of an autonomous drone is the lack of maintenance required due to its small platform and relatively inexpensive components. It can be assumed that this specific quadcopter will have a much larger workload when compared with a privately owned drone used for recreational purposes. The small/private airports that operate this drone will require multiple flights daily based on the airport's schedule that day. For the purpose of this project, the number of daily flights for the quadcopter is estimated to be two flights per day. If the quadcopter is estimated to fly two times per day and 260 days per year (5 days per week), that brings the estimated total number of flights per year to 520. Assuming each flight is approximately 10 minutes, the estimated total of yearly flight time would be roughly 87 hours.

For the maintenance required on normal aircraft, it is recommended that for every one hour of flight time, there should be roughly two hours of maintenance required. Two hours of maintenance will not be necessary for this purpose, but it provides perspective for the amount of maintenance required to ensure the optimal performance of an airborne vehicle. Assuming the quadcopter completes 10 flights per week, this would mean the estimated weekly flight time of the quadcopter would be 100 minutes (~1.67 hours). The following table outlines a basic maintenance checklist that can be completed for one week's worth of quadcopter flight time. The checklist includes maintenance procedures for the quadcopter itself and the additional bird deterrence components.

Maintenance	Description	Estimated Time for Completion
Visual Inspection	Inspect quadcopter to ensure no damage/issues	5 minutes
Clean Quadcopter Components	Clean off dirt from airframe, remove unwanted debris	10 minutes
Connections Inspection	Inspect power converter, Raspberry Pi GPIO connection, USB connection, ensure components mounted properly	5 minutes
Propeller Inspection	Inspect for deformation of propellers and screws, clean dust/dirt	5 minutes
Motor Inspection/Lubrication	Clean and lubricate all motors	10 minutes
Power Inspection	Ensure quadcopter and Raspberry Pi are operating to spec	10 minutes
Total Maintenance Required		45 minutes

Table 6: Maintenance Checklist for Every One Hour of Flight Time

The total estimated time to complete the weekly maintenance required is 45 minutes. This means that the estimated required yearly maintenance time would be 39 hours. Adhering to this checklist will greatly expand the lifespan of the quadcopter and will ensure optimal performance.

The airframe of the 3DR Iris+ is composed of high strength, durable plastics that are designed to sustain multiple high impact collisions. Assuming the quadcopter is operated responsibly and safely, the airframe of the 3DR Iris+ will remain in robust operating condition for at least five plus years. When not in use, the quadcopter should be disassembled and properly stored in its padded case at room temperature.

The four 920 kV brushed motors on the quadcopter will need to be maintained carefully to extend their lifespan. As stated in the maintenance checklist above, the motors should be cleaned and lubricated every 100 minutes of flight time. The only wearing part of the motor is the bearing which when cared for and lubricated properly, can last up to 200 hours of flight time. These bearings can also be replaced, with a set of four costing just \$10. With an estimated 87 hours of yearly flight time, it is recommended that the bearings should be replaced every two years.

The LiPo battery that powers both the quadcopter and Raspberry Pi also has a recommended lifespan of 300 charge cycles (full charges). LiPo batteries begin to age immediately after their first use, and are recommended to be replaced when the battery has declined to approximately 80 percent of its original capacity. In this case, the LiPo battery will need a full charge after each 10 minute autonomous flight. This means that one LiPo battery is estimated to last 50 hours of flight time. If a small/private airport completes two autonomous flights with the quadcopter per day, it would be ideal to have at least two LiPo batteries on hand. Assuming approximately 87 hours of flight time split between the two batteries per year, it is recommended that both LiPo's should be replaced yearly. This is the most costly maintenance that will be required for the quadcopter, with a replacement 8C 3s 5.1 Ah 11.1 V LiPo battery costing \$40. Therefore, the yearly cost of two replacement LiPo batteries would be \$80.

Adhering to the recommended maintenance above, it is estimated that the total cost of replacement parts for the quadcopter every two years would be \$170 (four LiPo

batteries, replacement set of bearings). The total maintenance required over that two year time span is estimated to be 78 hours.

Additional Considerations

Economic impact

The Federal Aviation Administration reported 14,661 bird strikes in 2018 totaling approximately \$1.2 billion in damages in the United States alone. This means that on average a bird strike on a commercial airline jet does approximately \$82,000 in damages. The FAA regulates approximately 15.8 million flights per year, therefore a bird strike occurs once every 1,077 flights, or 0.0927% of the time. A small airport, such as T.F. Green in Warwick, RI, had a total of 70,948 flights either land or depart its airspace in 2018 alone. A small airport the size of T.F. Green would see an average of 65 planes damaged by bird strikes per year, which would cause an average of \$5.3 million in damages. The cost of our prototype is \$725.03 with an estimated yearly maintenance cost of \$85.00. If our device were able to avert just one bird strike per year from a local airport with an average of 65 occurrences, that is a first year savings of \$81,190. This figure is dependent upon averages, but only assumes that the design is able to prevent a modest 1.5% of all bird strikes yearly.

Societal and Political impact

There is no significant societal or political impact. Since the drone complies with FAA regulations, its presence will not affect society or surrounding neighborhoods.

Ethical considerations

The ethical implications for our project were something that we took very seriously. Dealing directly with wildlife, it was our intention to limit any unnecessary distress to the animals and to avoid causing them any harm. When designing our prototype, we had to ensure that no elements of the design could be seen as malicious. Organizations such

as the ASPCA, PETA, WPA, etc all stand against animal cruelty by monitoring the welfare of all animals in a variety of situations. If our device were to be widely implemented, it would be important that groups such as these were not disconcerted by its effect on local wildlife.

Health, ergonomics, safety considerations

An airport is an environment in which safety is crucial for daily operations. For this reason, the FAA has strict regulations and restrictions on drones that are flying in the airspace of a commercial airport. It was made sure that the final design that the team has created conforms to these rules. Another safety consideration was the potential for the design to distract various airport personnel, such as pilots and air-traffic controllers, especially when using bright flashing lights. This problem was taken into account and ultimately the decision to use ultraviolet lighting was made to mitigate distraction.

Ultraviolet radiation is beyond the visible spectrum of human beings and ultraviolet bulbs only radiate slight traces of visible light. Birds are able to perceive this ultraviolet light, therefore, the inclusion of this type of lighting in the design seemed to be the correct decision.

Abiding by the FAA regulations and ensuring a product that will not inhibit airport operations were two important factors for limiting potential dangers.

Environmental impact and Sustainability considerations

This product will not impact the environment. Neither the UV lights that the drone flashes nor the sounds it emits have any negative impacts on the environment. When choosing which lights to use, the team conducted research on which types of lights would not cause any damage. This product will help decrease the amount of wildlife injuries and deaths, therefore helping the environment.

Further Work

Future goals for this project include further testing in an airport environment, redesigning to achieve a fully autonomous product, weather-proofing the design, and increasing battery life by optimizing payload weight.

Future Testing

Additional testing of this prototype is of utmost importance to prove that this concept is viable. This includes an in-depth analysis of the efficacy of this design in deterring birds, rigorous testing of the individual components and the prototype as a whole to determine durability and reliability scores, and performing tests in an airport setting.

Testing the efficacy of the current design at deterring birds from an airport is a crucial next step for this project. Being that this is the overarching goal, it is pivotal that the team gather data on exactly how effective the drone is at warding birds off of airport grounds. During the past semester, the team was not able to fully realize these tests. More minor tests were conducted to determine flight time and to conduct autonomous flights using the Mission Planner and autopilot feature of the Iris+ 3DR. Preliminary steps were taken to attempt to design a controlled test which would meet engineering testing criteria, but these tests were never carried out due to lack of time. To expound and actualize these tests would be the primary focus for the team going forward in order to determine the effectiveness of the design at performing its intended purpose.

Other tests for durability and reliability should also be considered going forward.

Specifically the power converter and other connections that are essential for powering and proper function of the drone are of most importance. If the power converter were to fail the Raspberry Pi and drone would both lose power and render the prototype completely nonfunctional.

Furthermore, testing that is actually carried out on airport grounds is important as this is the intended location for the operation of the final product. This would ensure that the

drone can be seamlessly integrated into the daily operations of a small airport and that it complies fully with the FAA regulations and regulations at a local level.

Other considerations include redesigning the current prototype to create a product that is fully autonomous. Our intention when we began this project was to ensure that the drone operated in a manner that would require as minimal intervention by airport staff as was possible. Ideally, the drone would be able to takeoff, fly a predetermined route, return to origin, land and charge its battery automatically. Using the Iris+ 3DR as the base for our design disallows this criteria. The battery must be switched out and charged as after the flight circuit has been completed, and the pre-flight checklist must be completed manually so that the flight path can be executed by the software. Using a drone that could takeoff automatically using preloaded flight data, perhaps taking off on a timed schedule, would be ideal. The battery could be charged automatically by modifying the current design in order to utilize a charging pad that would serve a dual-function as the takeoff point, landing point and docking station for charging. This way the entire procedure from takeoff to landing to charging would be fully autonomous and airport personnel would be able to allocate their attention elsewhere.

Additional alterations to the current design include weather-proofing the design to persist unabated and without reduced functionality in tempestuous weather conditions, increasing battery life if the desired flight time needs to be lengthened, and potentially modifying the sound and lighting intensity to further dissuade birds from gathering in the local area.

Conclusion

Overall, the design specifications of the project have been met. The design conforms with FAA regulations, which was a crucial first step to ensuring that this design could be marketed directly to airports. In its current form, the design provides minimal visible distraction to humans, with only UV light currently being implemented on the quadcopter. Once the basic design of the quadcopter itself was established, a sufficient battery was chosen to allow the quadcopter to perform effectively around a general aviation airport perimeter without any complications. The UV light components included on the quadcopter deter birds from areas within the light's visible radius. The bluetooth speaker emitting predatory bird sounds from the bottom of the drone also help to keep birds away from the nearby area.

References

1. "The Ultraviolet Receptor of Bird Retinas. - PubMed - NCBI."
<https://www.ncbi.nlm.nih.gov/pubmed/6740315>.
2. "Do Birds in Flight Respond to (Ultra)Violet Lighting? - Semantic Scholar."
[https://www.semanticscholar.org/paper/Do-birds-in-flight-respond-to-\(ultra\)violet-May-%C3%85str%C3%B6m/6ba26d150ea1f278d8cea0786c055e7e273d0742](https://www.semanticscholar.org/paper/Do-birds-in-flight-respond-to-(ultra)violet-May-%C3%85str%C3%B6m/6ba26d150ea1f278d8cea0786c055e7e273d0742)
3. "Cowbird Responses to Aircraft with Lights Tuned to Their Eyes: Implications for Bird–Aircraft Collisions | The Condor."
<http://www.bioone.org/doi/abs/10.1650/CONDOR-14-157.1>.
4. "Sonic Scarecrow; Bird Strikes on Aircraft." *The Economist*; London, April 16, 2016. https://search-proquest-com.uri.idm.oclc.org/docview/1809127645?accountid=28991&rfr_id=info%3Axri%2Fsid%3Aprimo .
5. "US9734684B2 - Perimeter Monitoring Using Autonomous Drones - Google Patents."
<https://patents.google.com/patent/US9734684B2/en?q=drone&q=autonomous+&q=lights>.
6. "US9987971B2 - Drone-Enhanced Vehicle External Lights - Google Patents."
<https://patents.google.com/patent/US9987971B2/en?q=drone&q=quadcopter&q=lights&oq=drone+quadcopter+with+lights>.
7. Halevy, Eyal, and Michael Amir. Airborne birdstrike prevention device. United States US4964331A, filed December 29, 1988, and issued October 23, 1990.
<https://patents.google.com/patent/US4964331A/en?q=bird+strike&q=prevention&oq=bird+strike+prevention>.

8. "DJI - The World Leader in Camera Drones/Quadcopters for Aerial Photography." DJI Official. Accessed December 17, 2018.
<https://www.dji.com/flame-wheel-arf/feature>
9. "Propeller Static & Dynamic Thrust Calculation." Flite Test | RC Planes, Quadcopters, Videos, Articles & More. Accessed December 17, 2018.
<https://www.flitetest.com/articles/propeller-static-dynamic-thrust-calculation.>
10. "How to Build A Drone | Step by Step Guide." Drone Nodes. December 12, 2018. Accessed December 17, 2018.
[http://dronenodes.com/how-to-build-a-drone/.](http://dronenodes.com/how-to-build-a-drone/)
11. Haponiuk, Bogna. "Bogna Haponiuk." Omni. Accessed December 17, 2018.
<https://www.omnicalculator.com/other/drone-flight-time#how-to-calculate-the-amp-draw.>
12. Cleary, Edward C., and Archie Dickey. "Guidebook for Addressing Aircraft/Wildlife Hazards at General Aviation Airports." Airport Wildlife. Accessed December 17, 2018.
<http://airportwildlife.com/pdf/ACRP 35 Guidebook for Addressing Aircraft Wildlife Hazards at General Aviation Airports.pdf.>
13. Begier, Michael J., Richard A. Dolbeer, PhD, and Jenny E. Washburn. "Protecting the Flying Public and Minimizing Economic Losses within the Aviation Industry." Aphis.usda. Accessed December 17, 2018.
[https://www.aphis.usda.gov/wildlife_damage/airline_safety/pdfs/FY2017_WS airports performance report Public final.pdf.](https://www.aphis.usda.gov/wildlife_damage/airline_safety/pdfs/FY2017_WS_airports_performance_report_Public_final.pdf.)
14. "Unmanned Aircraft Systems (UAS) Frequently Asked Questions." FAA Seal. August 29, 2018. Accessed December 17, 2018.
<https://www.faa.gov/uas/faqs/#aa.>
15. "Airman Knowledge Testing Center List." Faa. July 25, 2018. Accessed December 17, 2018.
https://www.faa.gov/training_testing/testing/media/test_centers.pdf.

16. "SUMMARY OF SMALL UNMANNED AIRCRAFT RULE (PART 107)." Faa. June 21, 2016. Accessed December 17, 2018. https://www.faa.gov/uas/media/Part_107_Summary.pdf.
17. "Frequently Asked Questions and Answers." Template. Accessed December 17, 2018. https://www.faa.gov/airports/airport_safety/wildlife/faq/.

Appendices

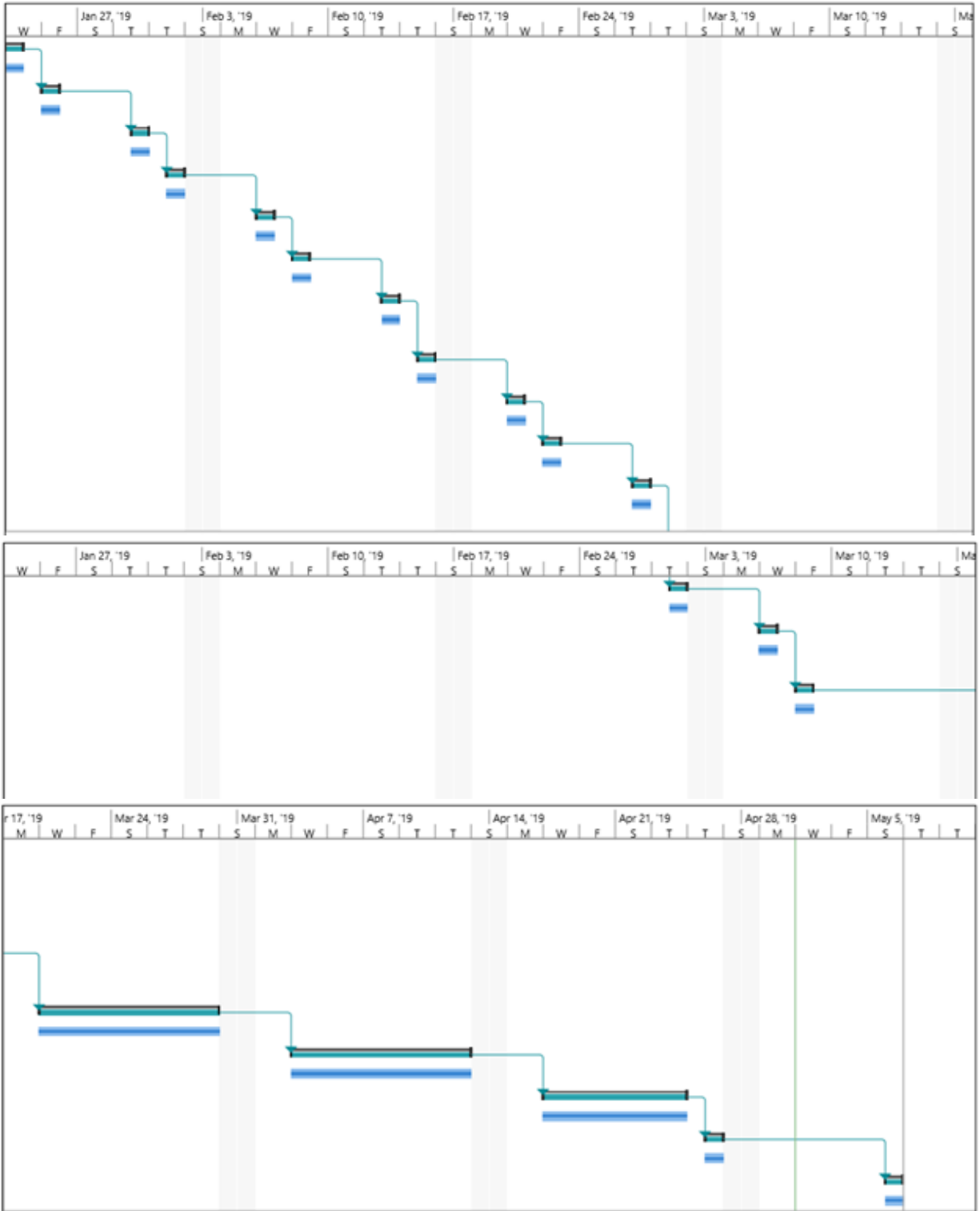

Figure 40: Gantt Chart