

Peter Ribbens (ribbensp@my.erau.edu)

Aroh Barjatya, Robert Clayton, Jacob Gambrill, Julio Guardado, Joshua Milford

Abstract

Balloon-borne radiosondes provide measurements of in-situ atmospheric data such as wind velocity, temperature, and pressure, amongst many others. The Space and Atmospheric Instrumentation Laboratory at Embry-Riddle Aeronautical University has developed low cost (< \$200, all inclusive) GPS-enabled radiosondes that are capable of having multiple balloons simultaneously in the air communicating to a single omni-directional ground station antenna. Each GPSsonde is equipped with a GPS Module for zonal and meridional winds, thermistor for in-situ temperature, and a pressure sensor. Slant range of greater than 120km is achieved through low-cost LoRa radio modules. Interference-free transmission timing between multiple payloads is done by time division multiplexing. The current design allows for up to six payloads to be simultaneously airborne and transmit live atmospheric data through one ground station. A higher number of simultaneous transmissions are also possible, albeit with a minor hit to spatial resolution. We present the system design, complete with hardware and software details, as well data from our current test flights and plans for future development.

GPSsonde System Requirements

- Measurements of the zonal, meridional, and vertical winds, temperature, and pressure
- Data transmission range greater than 120 km
- Altitude of 25 km or higher
- Simultaneous tracking of three or more payloads with single ground station
- Cost of less than \$200 per payload
- Cost of less than \$150 for Ground Station

Payload Price Details

#	Subsystem	Cost
1	Microcontroller	\$35.70
2	GPS Module	\$33.99
3	Thermistor	\$4.37
4	Power	\$13.39
5	Pressure Sensor	\$10.99
6	Electronics Shield	\$1.82
7	Payload Shell	\$8.00
8	Data Transmission	\$6.84
9	Flight Materials	\$48.54
Total Cost		~\$170

Payload Subsystem Components:

- Microcontroller
 - Adafruit Feather M0 with RFM95 900 MHz LoRa Radio
 - UFL SMT Antenna Connector
- GPS Module
 - uBlox NEO-M8N GPS Module
- Thermistor
 - PS103J2 10k Thermistor
 - 100k 0.1% Resistor
- Power
 - 1200 mAh 3.7V LiPo Battery
 - 12V 7W Flexible Polyimide Heater
 - JST 2 Pin Connector
 - Duckbill Off-On Red Bulb Switch
- Pressure Sensor
 - GY-63 MS5611 Pressure Sensor
- Electronics Shield
 - Printed Circuit Board
 - Molex Pico blade Connector
 - Screw Terminal Connector
- Payload Shell
 - Payload Shell Top
 - Payload Shell Bottom
 - Payload Mounting Screws
- Data Transmission
 - UFL SMA Connector
 - Cloverleaf Antenna
 - 6061 1' by 1' Aluminum Plate*
 - Micro USB Data Cable*
- Flight Materials
 - 2 inch Elastomeric Pipe Insulation
 - Parachute
 - 0.36" 50lb fishing line
 - 200 gram High Altitude Balloon
 - Helium (Price as of 02/2022)

Cost breakdown of the payload and ground station. Prices have been separated into each subsystem. Subsystem breakdown is shown on the right for specific components. Prices current as of Fall 2022.



Material layout of all components needed to build and fly a GPSsonde (left) and fully assembled ground station built and ready to receive data (right)

Payload Components

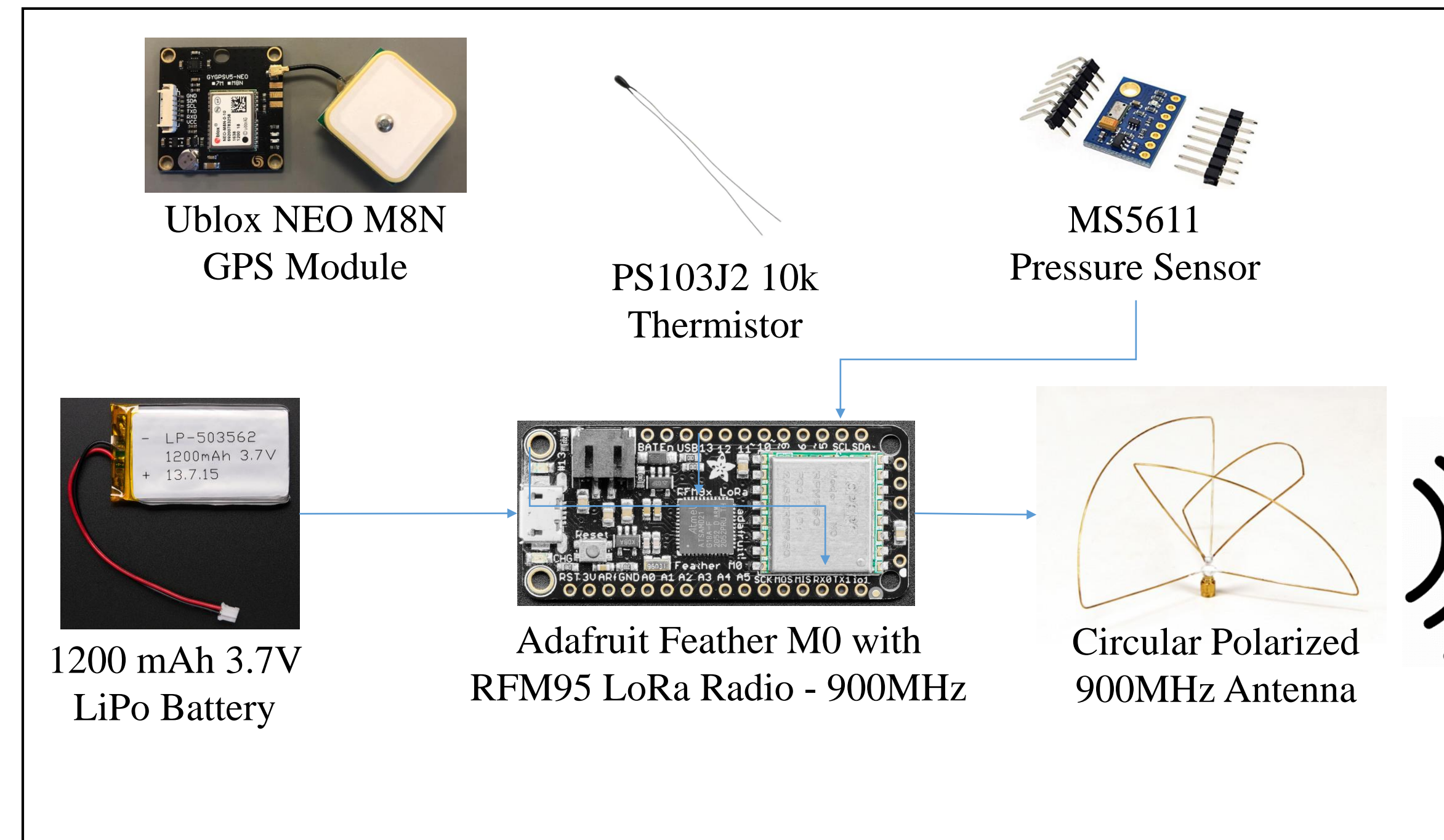

Ground Station Components

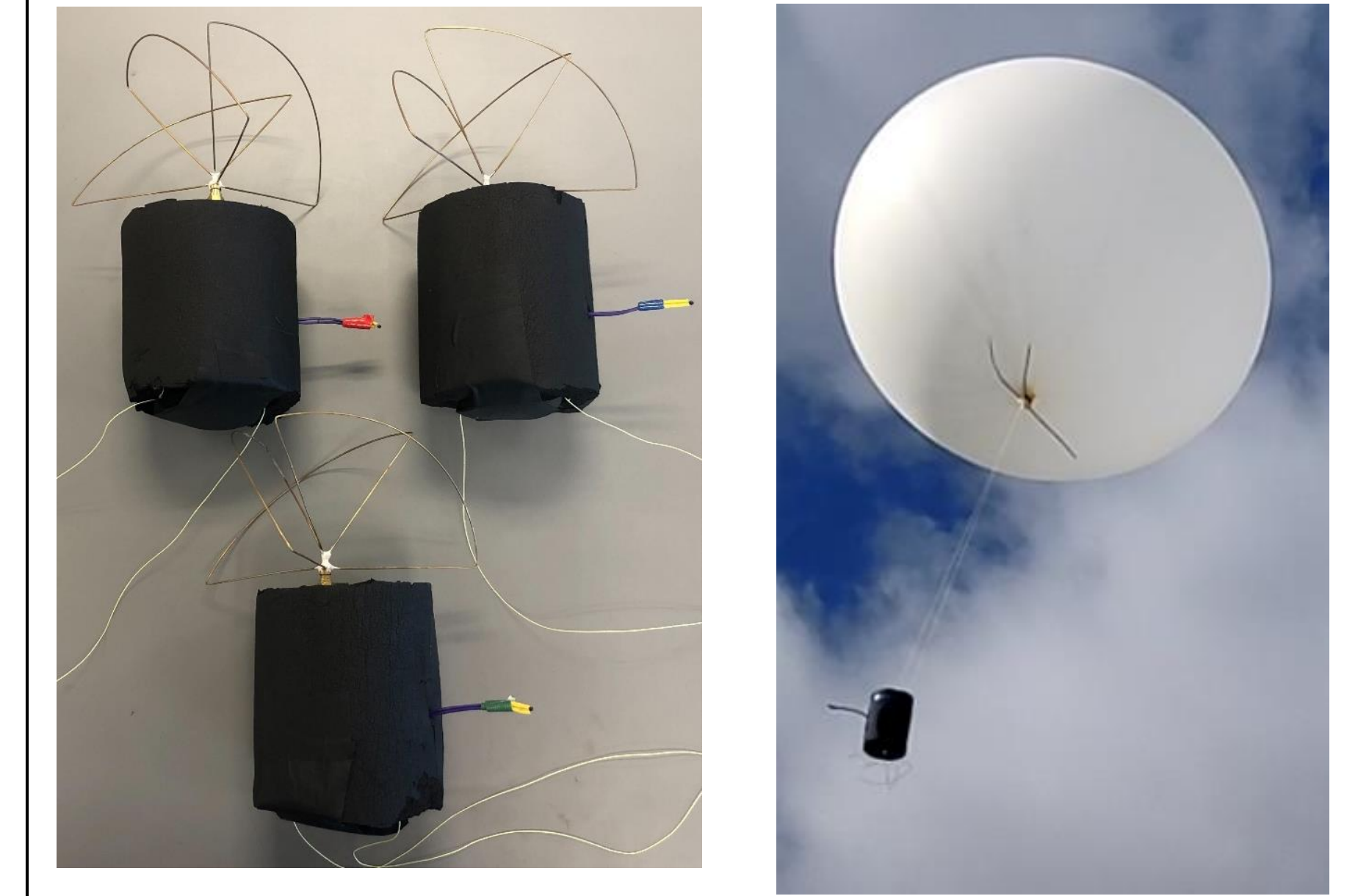
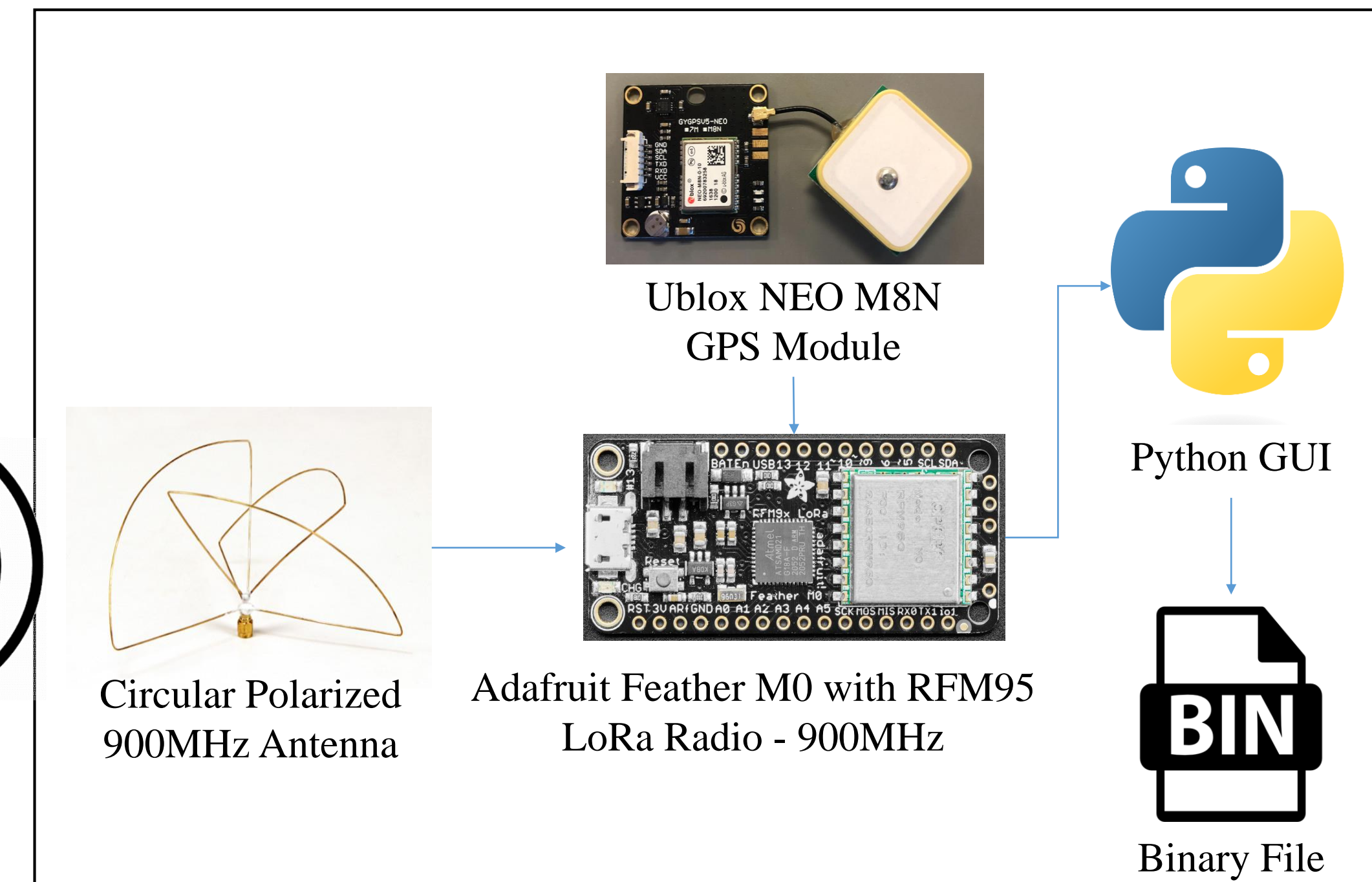

GPSsondes fully assembled and in-flight configuration.

Thermistor Temperature Consistency and Precision Testing

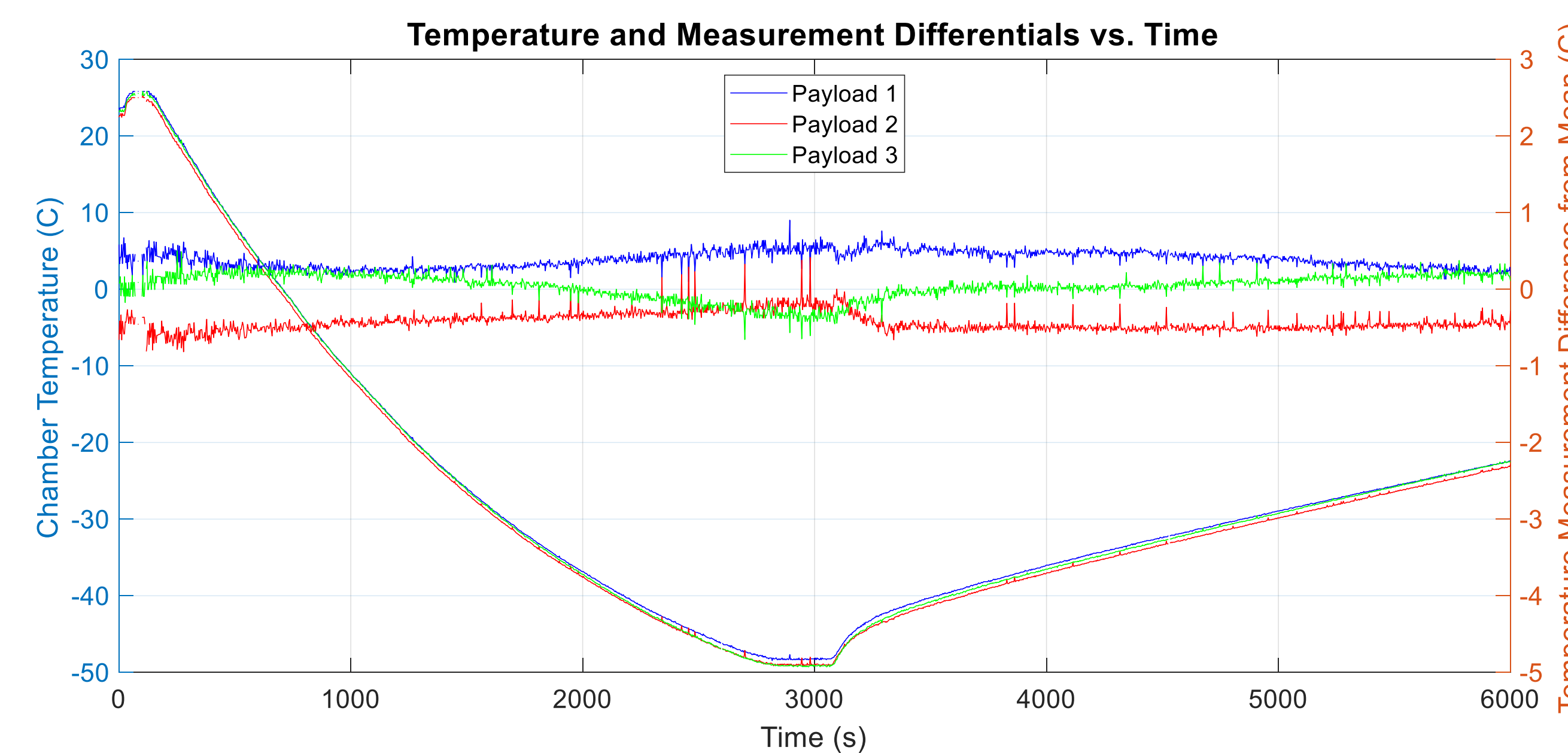

Thermistor testing results in a thermal chamber. Test setup pictured below with the data from the chamber test pictured above. Shown on the right are in-flight results of two of the same thermistors. The third balloon burst early.



Altitude vs. Temperature (Up Leg)

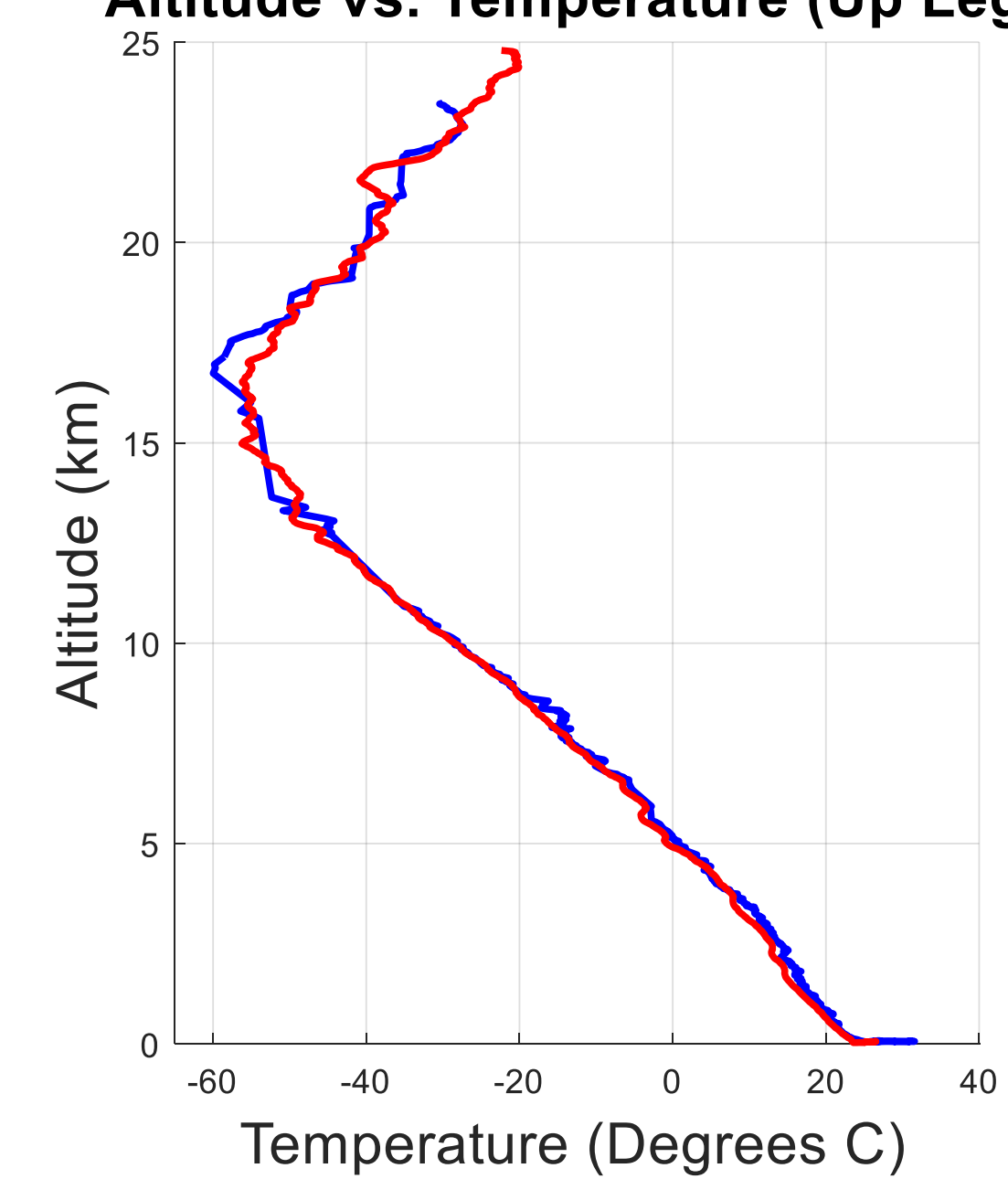

Ground Station Live GUI

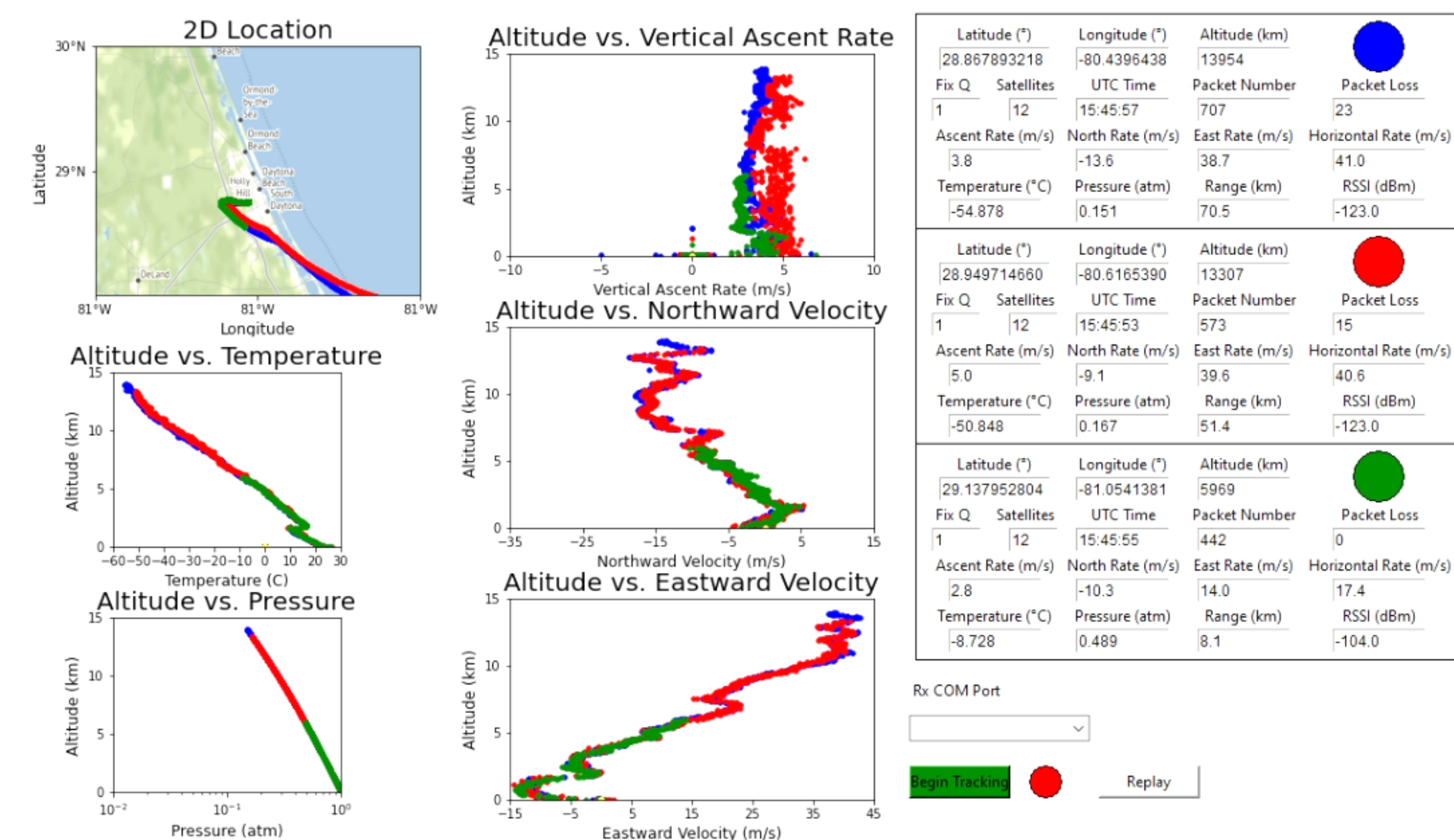

Screenshot of the flight data. Data is plotted on the subplots on the left of the GUI, while housekeeping data is displayed on the right. When a new payload is received by the ground station, it appears on the right and as a different color on the plots.

Flight Test Results

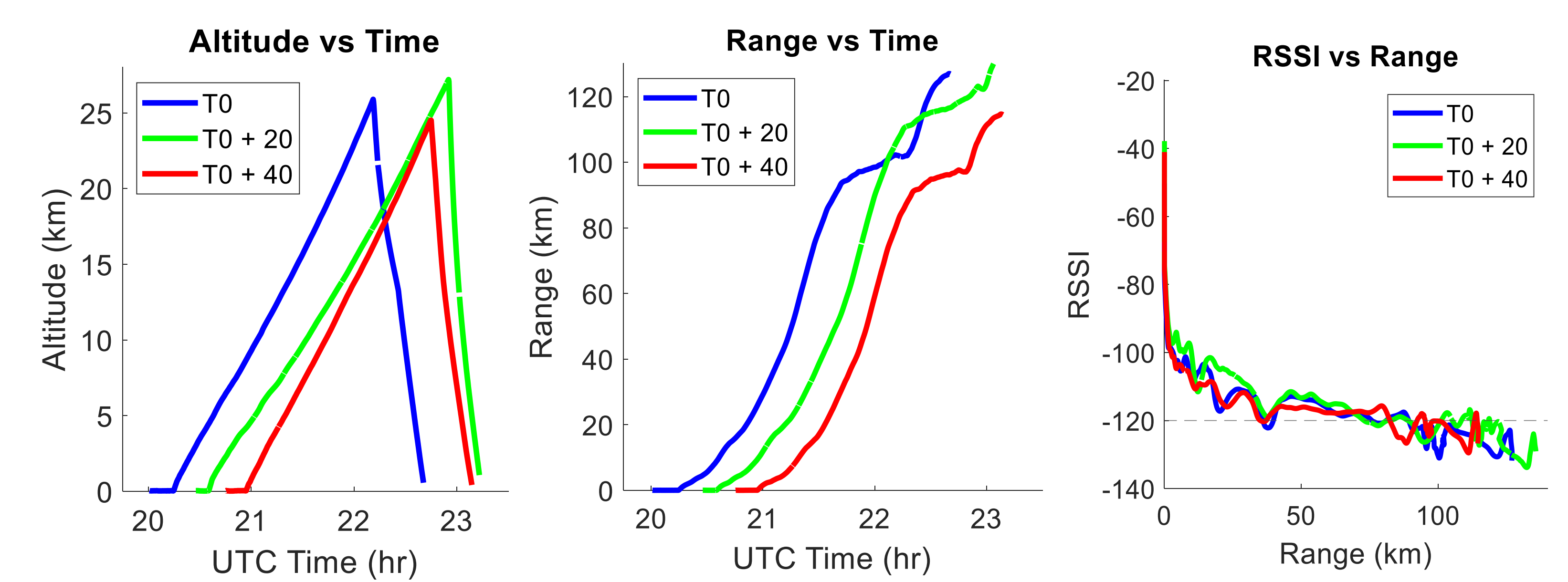

Flight data results from April 4th. Shown are an altitude versus time plot, range versus time plot, RSSI vs Range plot, and picture of GPSsonde being assembled into flight configuration

Flight Data During Thunderstorm Activity

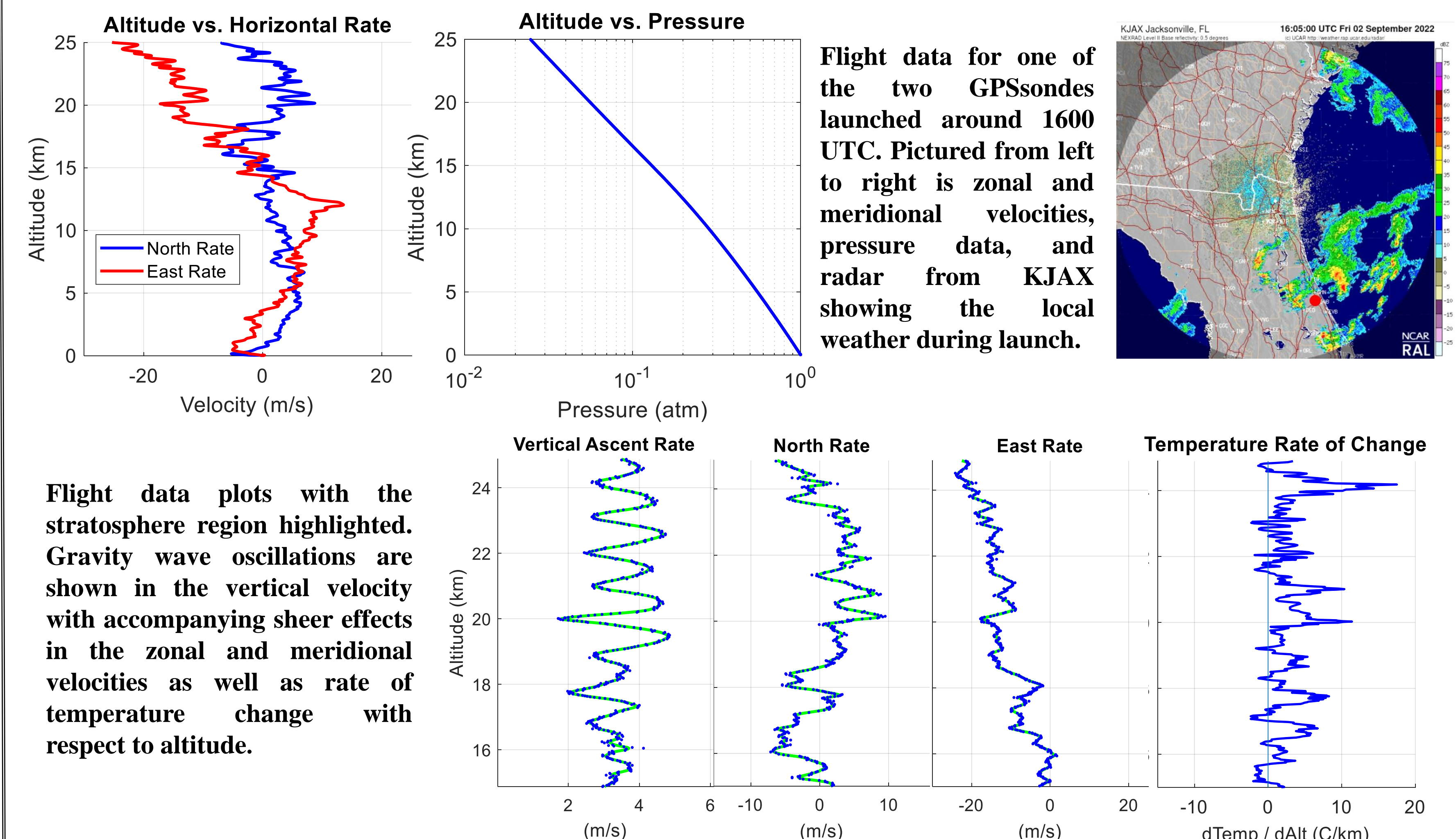

Flight data plots with the stratosphere region highlighted. Gravity wave oscillations are shown in the vertical velocity with accompanying shear effects in the zonal and meridional velocities as well as rate of temperature change with respect to altitude.

Summary and Future Work

- We have built and tested a GPSsonde setup that allows 3 simultaneous sondes in the air giving ~25 m spatial resolution on measured quantities.
- The spatial resolution for 6 simultaneous sondes is ~50 m.
- Current electronics and data transmission configuration allows for the inclusion of additional sensors
- Launches can be sequential in time or simultaneous from multiple locations.
- GPSsondes will be launched during the Apophis Eclipse sounding rocket campaign during the 2023 and 2024 Solar Eclipses from White Sands Missile Range and Wallops Flight Facility to separate ground-based effects on the ionosphere from topside influences.

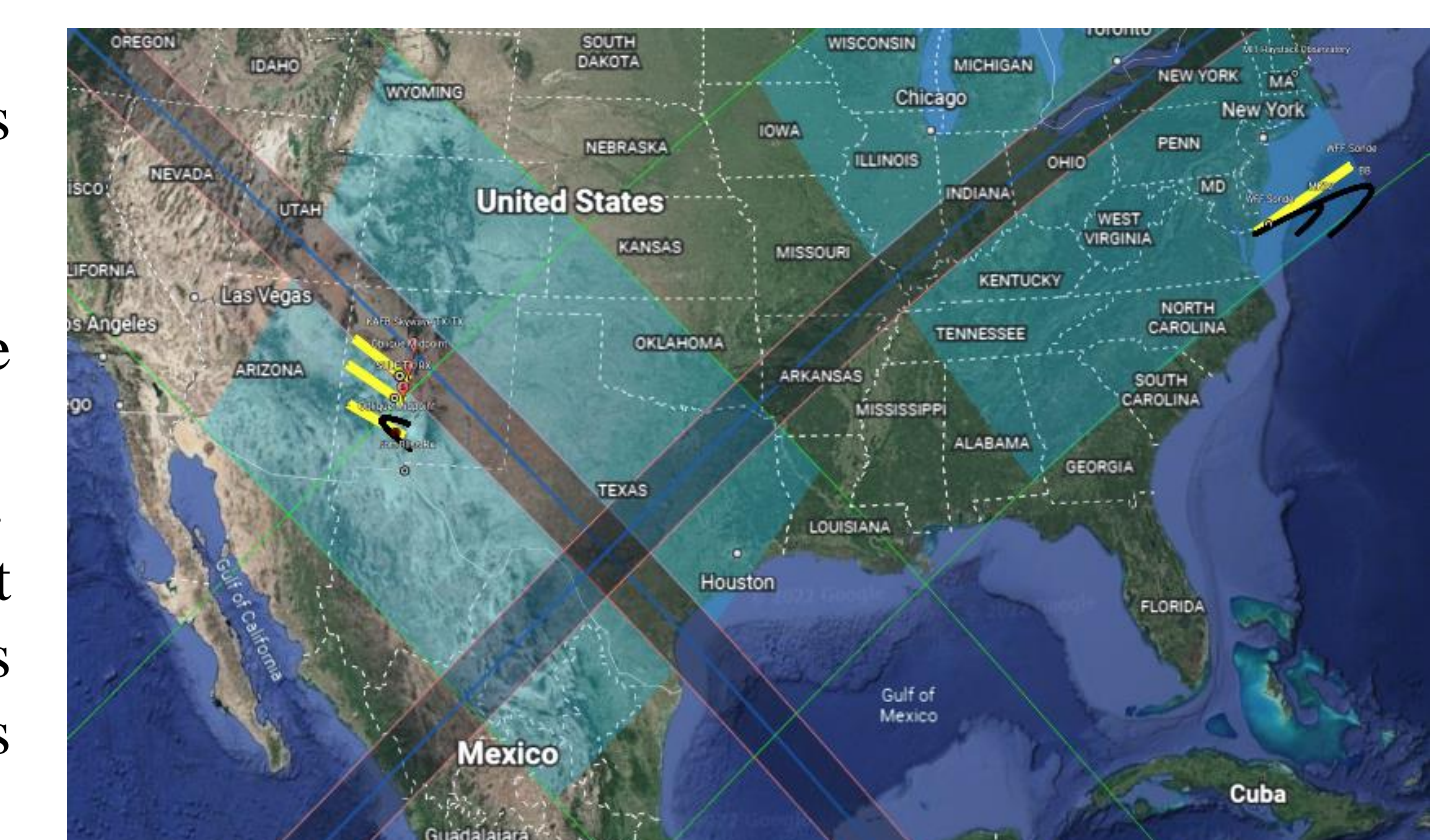

Apophis Eclipse Sounding Rocket Campaign